



# ZT HD

Owner/Operator Manual

Manuel Du Propriétaire/Utilisateur

## Models

**991082 – ZT HD48**

(Serial No. 010000 and up)

**991083 – ZT HD52**

(Serial No. 010000 and up)

**991084 – ZT HD60**

(Serial No. 010000 and up)

**991090 – ZT HD44**

(Serial No. 010000 and up)

**991091 – ZT HD60**

(Serial No. 000101 and up)



Gasoline containing up to 10% ethanol (E10) or up to 10% MTBE (methyl tertiary butyl ether) is acceptable for use in this machine.

The use of any gasoline exceeding 10% ethanol (E10) or 10% MTBE will void the product warranty.

Il est possible d'utiliser de l'essence contenant jusqu'à 10% d'éthanol (E10) ou 10% de MTBE (éther méthyl-tertiobutylique) sur cette machine.

L'utilisation d'une essence contenant plus de 10% d'éthanol (E10) ou de 10% de MTBE annulent la garantie.



**(GB)** ENGLISH

**(F)** FRANÇAIS

04414600 11/11

Printed in USA

# TABLE OF CONTENTS

Safety .....	4	Storage .....	32
Assembly .....	12	Accessories .....	32
Controls and Features .....	13	Service Parts .....	32
Operation .....	14	Specifications .....	33
Maintenance Schedule .....	19	Warranty .....	35
Service and Adjustments .....	20		

## INTRODUCTION

### NON-ENGLISH MANUALS



Manuals in languages other than English may be obtained from your Dealer. Visit your dealer or [www.gravely.com](http://www.gravely.com) for a list of languages available for your equipment.



Manuals printed in languages other than English are also available as a free download on our website:

<http://www.gravely.com>

### MANUALES EN IDIOMAS DIFERENTES DEL INGLES



Puede obtener manuales en idiomas diferentes del inglés en su distribuidor. Visite a su distribuidor o vaya a [www.gravely.com](http://www.gravely.com) para obtener una lista de idiomas disponibles para su equipo.



También puede imprimir manuales en idiomas diferentes del inglés descargándolos gratuitamente de nuestra página Web:

<http://www.gravely.com>

### MANUELS NON ANGLAIS



Des manuels dans différentes langues sont disponibles chez votre revendeur. Rendez-vous chez votre revendeur ou allez sur le site [www.gravely.com](http://www.gravely.com) pour consulter la liste des langues disponibles pour votre équipement.



Les manuels imprimés dans des langues différentes de l'anglais sont également disponibles en téléchargement gratuit sur notre site Web :

<http://www.gravely.com>

### THE MANUAL

Before operation of unit, carefully and completely read your manuals. The contents will provide you with an understanding of safety instructions and controls during normal operation and maintenance.

All reference to left, right, front, or rear are given from operator sitting in the operation position and facing the direction of forward travel.

### ENGINE MANUAL

The engine on this unit is covered by a separate manual specific to the engine. This manual is included in the literature package that shipped with the unit. Refer to this manual for engine service recommendations. If the engine manual is not available, contact the engine manufacturer for a replacement manual.

### SERVICE AND REPLACEMENT PARTS

When ordering publications, replacement parts, or making service inquiries, know the Model and Serial numbers of your unit and engine.

Numbers are located on the product registration form in the literature package. They are printed on a serial number label, located on the frame of your unit (Figure 1).

Serial Number Label



Figure 1

- Record Unit Model and Serial numbers here.

- Record Engine Model and Serial numbers here.

## PRODUCT REGISTRATION

The Gravelly dealer must register the product at the time of purchase. Registering the product will help the company process warranty claims or contact you with the latest service information. All claims meeting requirements during the limited warranty period will be honored, whether or not the product registration card is returned. Keep a proof of purchase if you do not register your unit.

**Customer Note:** If the Dealer does not register your product, please fill out, sign and return the product registration card to Gravelly or go to [www.gravelly.com](http://www.gravelly.com) on the Internet.

## UNAUTHORIZED REPLACEMENT PARTS

Use only Gravelly replacement parts. The replacement of any part on this equipment with anything other than a Gravelly authorized replacement part may adversely affect the performance, durability, and safety of this unit and may void the warranty. Gravelly disclaims liability for any claims or damages, whether regarding warranty, property damage, personal injury or death arising out of the use of unauthorized replacement parts.

**NOTE:** To locate your nearest Gravelly Dealer, go to [www.gravelly.com](http://www.gravelly.com).

## DISCLAIMER

Gravelly reserves the right to discontinue, change, and improve its products at any time without public notice or obligation to the purchaser. The descriptions and specifications contained in this manual were in effect at printing. Equipment described within this manual may be optional. Some illustrations may not be applicable to your unit.

## DEALER DELIVERY

Dealer should:

1. Test brakes after unit is assembled to be sure adjustment has not been disturbed in shipment (See *Parking Brake Interlock System* on page 14). Wheel brakes are properly adjusted at factory.
2. Check the safety interlock system to make sure that it is functioning properly. With operator on seat, unit must not start unless steering levers are in neutral (N) and Power Takeoff (PTO) is disengaged (Off). Engine must stop if operator leaves seat when steering levers are in any drive position or PTO is engaged (On). See *Safety Interlock System* on page 14.
3. Fill out Original Purchaser Registration Card and return the card to Gravelly.
4. Explain Limited Warranty Policy.
5. Explain recommended lubrication and maintenance. Advise customer on adjustments. Instruct customer on controls and operation of unit. Discuss and emphasize the Safety Precautions. Give customer Owner/Operator, Parts, and Engine Manuals. Advise customer to thoroughly read and understand them.

**Customer Note:** Your Dealer has been provided complete set-up and preparation instructions which must be completed prior to you taking delivery of this unit. The dealer is required to review important information in this manual with you before or upon delivery of the unit or attachment.

# SAFETY



**WARNING:** This cutting machine is capable of amputating hands and feet and throwing objects. Failure to observe the safety instructions in the manuals and on decals could result in serious injury or death.

Slopes are a major factor related to loss-of-control and tip-over accidents. Operation on all slopes requires extra caution.

Tragic accidents can occur if the operator is not alert to the presence of children. Never assume that children will remain where you last saw them.

Gasoline is extremely flammable and the vapors are explosive, handle with care.

Disengage attachment, stop unit and engine, remove key, engage parking brake, and allow moving parts to stop before leaving operator's position.



**WARNING:** POTENTIALLY HAZARDOUS SITUATION! If not avoided, **COULD RESULT** in death or serious injury.



**CAUTION:** POTENTIALLY HAZARDOUS SITUATION! If not avoided, **MAY RESULT** in minor or moderate injury. It may also be used to alert against unsafe practices.

## NOTATIONS

**NOTE:** General reference information for proper operation and maintenance practices.

**IMPORTANT:** Specific procedures or information required to prevent damage to unit or attachment.

## PRACTICES AND LAWS

Practice usual and customary safe working precautions, for the benefit of yourself and others. Understand and follow all safety messages. Be alert to unsafe conditions and the possibility of minor, moderate, or serious injury or death. Learn applicable rules and laws in your area, including those that may restrict the age of the operator.

## REQUIRED OPERATOR TRAINING

Original purchaser of this unit was instructed by the seller on safe and proper operation. If unit is to be used by someone other than original purchaser (loaned, rented or sold), **ALWAYS** provide this manual and any needed safety training before operation.

## SAFETY DECALS AND LOCATIONS

**ALWAYS** replace missing or damaged Safety Decals. Refer to Figure 2 for Safety Decal locations.

## SAFETY ALERT SYMBOL

These are safety alert symbols. They mean:

- ATTENTION!**
- YOUR SAFETY IS INVOLVED!**

When you see this symbol:

- BECOME ALERT!**
- OBEY THE MESSAGE!**



OL1253



OL3900

## SIGNAL WORDS

The safety alert symbols above and signal words below are used on decals and in this manual.

Read and understand all safety messages.



**DANGER:** IMMINENTLY HAZARDOUS SITUATION! If not avoided, **WILL RESULT** in death or serious injury.

**NOTE:** This unit may contain any of the following safety decals.

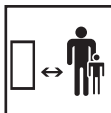

Figure 2

## 1. Danger! TO AVOID SERIOUS INJURY OR DEATH



Read Owner/Operator Manual. Allow operation only by properly trained adult, never children.



Keep children and others away from unit while operating.



Never direct discharge toward other people. Thrown objects can cause injury.



Look down and behind before and while backing.



Keep children out of work area and under watchful care of a responsible adult.

**NEVER CARRY CHILDREN.**



Go up and down slopes, not across.  
**DO NOT** operate on slopes over 17°.



- If machine stops going uphill, stop blade and back down slowly.
- Avoid sudden turns.
- Keep safety devices (guards, shields, switches, etc.) in place and working.
- Check interlock system per manual before use.
- Understand location and function of all controls.
- Never allow operation by untrained persons.

## 2. DANGER



DANGER!



Read and understand the operator's manual before operating unit.

### 2.1 Dismemberment Hazard



To avoid dismemberment hazard do not put hands near rotating blades.



To avoid dismemberment hazard do not put hands near moving belts.



Keep hands away from all rotating or moving parts.



Keep all guards and shields in place.

### 2.2 Discharge Hazard



Discharge Hazard – NEVER direct discharge toward people, pets or property. Thrown objects can cause injury or damage.



Keep children and others away from unit while unit is in operation.

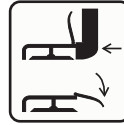

Do not operate mower unless all guards are in operating position or bagger is attached.

### 2.3 Tipping Hazard



Avoid tipping hazard.



DO NOT operate on slopes over  $15^\circ$ .



DO NOT operate on slopes over  $15^\circ$ .

### 2.4 Service Hazard



Before servicing unit do the following:

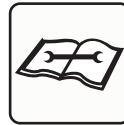

Read owners manual before servicing or making adjustments to unit.



Set parking brake.

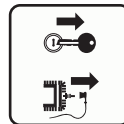

Remove key and disconnect spark plug before servicing or making adjustments to unit.

## 2.5 Bystander Hazard



DO NOT operate the unit in the presence of bystanders.



Do not carry passengers.



Look behind when operating the unit in reverse.

## 2.6 Loss of Traction Hazard



If loss of traction is experienced do the following:

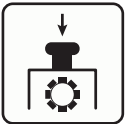

Disengage PTO.



Look before backing.  
Proceed off slope slowly.



Do not try to turn or speed up.

## 3. DANGER!



Discharge Hazard – NEVER operate unit without discharge chute in operating position. Thrown objects can cause injury or damage.



Do not operate mower unless all guards are in operating position or bagger is attached.

## 4. DANGER!



AVOID INJURY. Stay clear of rotating parts.

## 5. DANGER!



Discharge Hazard - NEVER direct discharge toward people, pets or property. Thrown objects can cause injury or damage.



Dismemberment Hazard – NEVER stick hands or feet under deck or shielded areas.



Shut off engine, remove key, and read manual before servicing or making adjustments to unit.



Keep children and others away from unit while unit is in operation.



Keep feet and hands away from all rotating or moving parts.



DO NOT step or stand in this area.

## 6. WARNING!



Discharge Hazard - NEVER operate unit without discharge chute in operating position. Thrown objects can cause injury or damage.

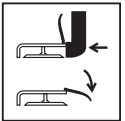

Do not operate mower unless all guards are in operating position or bagger is attached.

## 7. DANGER!



Discharge Hazard – NEVER operate unit without discharge chute in operating position. Thrown objects can cause injury or damage.



Do not operate mower unless all guards are in operating position or bagger is attached.

## 8. DANGER!



Always keep feet and hands away from rotating parts.



Always stand clear of discharge area. Do not direct discharge toward other people



Keep people away from unit while operating.



Shut off engine, remove key, read manual before you adjust or repair unit.



NO STEP! Always keep feet away from rotating parts.

## 9. HOT SURFACES!



DO NOT touch parts which are hot from operation. ALWAYS allow parts to cool.



## 10. CAUTION!



No smoking.

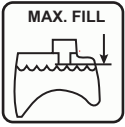

Fill fuel tank to bottom of neck – MAXIMUM.



**WARNING:** Over Filling may cause severe damage to evaporative system!

- Never fill fuel tank when engine is running, hot or unit is indoors. Never overfill fuel tank.
- Replace fuel cap securely and clean up spilled fuel.

## 11. ROTATING PARTS!



AVOID INJURY. Stay clear of rotating parts.

## EMISSION CONTROL SYSTEM

This equipment and/or its engine may include exhaust and evaporative emissions control system components required to meet U.S. Environmental Protection Agency (EPA) and/or California Air Resources Board (CARB) regulations. Tampering with emission controls and components by unauthorized personnel may result in severe fines or penalties. Emission controls and components can only be adjusted by an Ariens Company dealer or an authorized engine manufacturer's service center. Contact your Ariens Company Equipment Retailer concerning emission controls and component questions.

## SAFETY RULES

Read, understand, and follow all safety practices in Owner/Operator Manual before beginning assembly. Failure to follow instructions could result in personal injury and/or damage to unit.

ALWAYS remove key and/or wire from spark plug before assembly. Unintentional engine start up can cause death or serious injury. Complete a walk around inspection of unit and work area to understand:

- Work area
- Your unit
- All safety decals

Determine which attachments are needed and can be used safely.

Inspect unit before each use for: missing or damaged decals and shields, correctly operating safety interlock system, and deterioration of grass catchers. Replace or repair as needed.

ALWAYS check overhead and side clearances carefully before operation.

ALWAYS be aware of traffic when operating along streets or curbs.

Keep children and people away.

Keep children out of work area and under watchful care of a responsible adult.

Keep area of operation clear of all toys, pets, and debris. Thrown objects can cause injury.

Check for weak spots on docks, ramps or floors. Avoid uneven work areas and rough terrain. Stay alert for hidden hazards or traffic. DO NOT operate near drop-offs, ditches, or embankments. Unit can suddenly turn over if a wheel is over the edge of a cliff or ditch, or if an edge caves in.

Data indicates that operators, age 60 and above, are involved in a larger percentage of riding mower related injuries. These operators should evaluate their ability to operate the riding mower safely enough to protect themselves and others from serious injury.

Read the entire Owner/Operator manual and other training material. If the operator or the mechanic cannot read the manual, it is the owner's responsibility to explain it to them.

Only the user can prevent and is responsible for accidents or injuries occurring to themselves, other people or property.

Only trained adults may operate or service unit. Training includes actual operation.

Local regulations may restrict the age of the operator.

NEVER allow children to operate or play on or near unit. Be alert and shut off unit if children enter area.

NEVER operate unit after or during the use of medication, drugs or alcohol. Safe operation requires your complete and unimpaired attention at all times.

DO NOT wear loose clothing or jewelry and tie back hair that may get caught in rotating parts.

Wear adequate outer garments.

NEVER wear open sandals or canvas shoes during operation. Wear adequate safety gear, protective gloves and footwear.

Wear proper footwear to improve footing on slippery surfaces.

Always wear safety goggles or safety glasses with side shields when operating mower.

Moving parts can cut or amputate fingers or a hand. Wrap blade(s) or wear gloves to service. On multiblade mowers, rotation of one blade will cause all blades to rotate.

NEVER place your hands or any part of your body or clothing inside or near any moving part while unit is running.

ALWAYS keep hands and feet away from all rotating parts during operation. Rotating parts can cut off body parts.

ALWAYS keep body and hands away from pin holes or nozzles which eject hydraulic fluid under pressure.

DO NOT touch parts which are hot. Allow parts to cool.

ALWAYS keep hands and feet away from all pinch points.

Fumes from the engine exhaust can cause death or serious injury. DO NOT run engine in an enclosed area. Always provide good ventilation.

Read, understand, and follow all instructions in the manual and on the machine before starting. Understand:

- How to operate all controls
- The functions of all controls
- How to STOP in an Emergency
- Braking and steering characteristics
- Turning radius and clearances

Keep safety devices or guards in place and functioning properly. NEVER modify or remove safety devices.

Do not operate without either entire grass catcher or the discharge guard in place.

Stop engine before removing grass catcher or unclogging chute.

Ensure Safety Interlock System is functioning properly. DO NOT operate unit if safety interlock is damaged or disabled.

Start and operate unit only when seated in operator's position. Steering control levers must be in neutral, PTO disengaged and parking brake set when starting engine.

Use care when approaching blind corners, shrubs, trees or other objects that may obscure vision.

Dust, smoke, fog, etc. can reduce vision and cause an accident. Mow only in daylight or good artificial light.

Avoid slippery surfaces. Always be sure of your footing.

DO NOT mow on wet grass. Reduced traction could cause sliding and effect the machine's stability.

Watch for traffic when operating near or crossing roadways.

Never carry passengers.

DO NOT try to stabilize the machine by putting your foot on the ground.

Never direct discharge towards persons or property that may be injured or damaged by thrown objects. Use extreme caution on gravel surfaces.

Always stand clear of the discharge area.

ALWAYS disengage PTO, stop unit and engine, remove key, engage parking brake and allow moving parts to stop before leaving operator's position.

Never engage PTO while raising attachment or when attachment is in raised position.

DO NOT operate at too fast a rate. DO NOT change engine governor settings or over-speed engine. Slow down before turning.

DO NOT operate in reverse unless absolutely necessary. ALWAYS look down and behind before and while backing.

Stop and inspect equipment if you strike an object or if there is an unusual vibration.

Repair, if necessary, before restarting. Never make adjustments or repairs with the engine running.

Mower blades are sharp and can cut you. Wrap the blade(s) or wear gloves, and use extra caution when servicing them. NEVER weld or straighten mower blades.

Rotation of one blade may cause rotation of the other blades.

Take all possible precautions when leaving unit unattended. Shut off engine. Remove wire from spark plug and secure it away from spark plug.

ALWAYS remove key to prevent unauthorized use.

Know the weight of loads. Limit loads to those you can safely control and the unit can safely handle.

Disengage PTO when attachment is not in use. ALWAYS turn off power to attachment when travelling, crossing driveways, etc.

Mow up and down slopes, not across them. DO NOT operate on slopes of more than 15 degrees.

Operation on slopes may lead to loss of steering control. When operating on slopes be prepared to react to an emergency situation:

- Return steering levers to neutral position.
- Immediately set parking brake.
- Turn off PTO and engine.

Keep all movements on the slope *slow* and *gradual*. Do not make sudden changes in speed or direction.

Avoid starting or stopping on the slope. If tires lose traction, disengage the blades and proceed slowly *straight* down the slope.

If you cannot back up a slope or you feel uneasy on it, do not mow it.

DO NOT park on slopes unless necessary.

When parking on slope always chock or block wheels. Always set parking brake.

Use a slow speed. Tires may lose traction on slopes even though the brakes are functioning properly.

Do not bypass transmission when on a slope.

Tow only with a machine that has a hitch designed for towing. Do not attach towed equipment except at the hitch point.

Follow the manufacturer's recommendations for weight limits for towed equipment and towing on slopes.

NEVER allow children or others in or on towed equipment.

On slopes, the weight of the towed equipment may cause loss of control.

Travel slowly and allow extra distance to stop.

Use extra care when loading or unloading unit onto trailer or truck.

Secure unit chassis to transport vehicle.

NEVER secure from rods or linkages that could be damaged.

DO NOT transport machine while engine is running.

ALWAYS turn off power to attachment and shut off fuel when transporting unit.

Keep unit free of debris. Clean up oil or fuel spills.

This product is equipped with an internal combustion type engine. DO NOT use unit on or near any unimproved, forest-covered or brush covered land unless exhaust system is equipped with a spark arrester meeting applicable local, state or federal laws. A spark arrester, if it is used, must be maintained in effective working order by operator.

Fuel is highly flammable and its vapors are explosive. Handle with care. Use only an approved gasoline container with an appropriately sized dispensing spout.

NO smoking, NO sparks, NO flames.

ALWAYS allow engine to cool before servicing.

NEVER fill fuel tank when engine is running or hot from operation.

NEVER fill or drain fuel tank indoors.

Replace fuel cap securely and clean up spilled fuel.

Properly remove fuel before tipping unit.

Never fill containers inside a vehicle or on a truck or trailer bed with a plastic liner. Always place containers on the ground away from your vehicle before filling.

When practical, remove gas-powered equipment from the truck or trailer and refuel it on the ground. If this is not possible, then refuel such equipment on a trailer with a portable container, rather than from a gasoline dispenser nozzle.

Keep the nozzle in contact with the rim of the fuel tank or container opening at all times until fueling is complete. Do not use a nozzle lock-open device.

If fuel is spilled on clothing, change clothing immediately.

Avoid Electric Shock. Objects contacting both battery terminals at the same time may result in injury and unit damage. DO NOT reverse battery connections.

Reverse connections may result in sparks which can cause serious injury. Always connect positive (+) lead of charger to positive (+) terminal, and negative (-) lead to negative (-) terminal.

ALWAYS disconnect negative (-) cable FIRST and positive (+) cable SECOND. ALWAYS connect positive (+) cable FIRST, and negative (-) cable SECOND.

Explosive Gases from battery can cause death or serious injury. Poisonous battery fluid contains sulfuric acid and its contact with skin, eyes or clothing can cause severe chemical burns.

No flames, No sparks, No smoking near battery.

ALWAYS wear safety glasses and protective gear near battery. Use insulated tools.

DO NOT TIP battery beyond a 45° angle in any direction.

ALWAYS keep batteries out of reach of children.

Battery posts, terminals and related accessories contain lead and lead compounds, chemicals known to the State of California to cause cancer and reproductive harm. Wash hands after handling.

ALWAYS block wheels and know all jack stands are strong and secure and will hold weight of unit during maintenance.

Release pressure slowly from components with stored energy.

NEVER attempt to make any adjustments to unit while engine is running (except where specifically recommended). Stop engine, remove key or spark plug wire and wait for all moving parts to stop before servicing or cleaning.

Check parking brake operation frequently. Adjust and service as required.

ALWAYS maintain unit in safe operating condition. Damaged or worn out muffler can cause fire or explosion.

Maintain or replace safety and instruction labels, as necessary.

NEVER store unit with fuel in fuel tank, inside a building where any ignition sources are present.

Shut off fuel and allow engine to cool completely before storing in closed area or covering unit.

Clean grass and debris from unit, especially from around muffler and engine, to help prevent fires.

For extended storage, shut off fuel and clean unit thoroughly. See engine manual for proper storage.

Lower cutting deck unless a positive mechanical lock is used.

Use only attachments or accessories designed for your unit.

Check all hardware at regular intervals, especially blade attachment bolts. Keep all hardware properly tightened.

Check attachment components frequently. If worn or damaged, replace with manufacturer's recommended parts.

# ASSEMBLY



**WARNING: AVOID INJURY.**  
Read and understand entire  
*Safety* section before proceeding.

## UNIT ASSEMBLY

### Package Contents:

Unit, Mower Deck and Literature Pack

### Preparation Checklist

Refer to the Owner/Operator manual as required.

1. Unpack Unit – Remove shrink wrap and packaging materials.
2. Remove Unit From Container – Open Bypass Valves (dump valves) (See *Moving the Unit with the Engine Off* on page 18).  
Push unit from container onto a level surface. Close the bypass valves.
3. Tires – See *Specifications* on page 33.



**CAUTION:** Avoid injury! Explosive separation of tire and rim parts is possible when they are serviced incorrectly:

- Do not attempt to mount a tire without the proper equipment and experience to perform the job.
- Do not inflate the tires above the recommended pressure.
- Do not weld or heat a wheel and tire assembly. Heat can cause an increase in air pressure resulting in an explosion. Welding can structurally weaken or deform the wheel.
- Do not stand in front or over the tire assembly when inflating. Use a clip-on chuck and extension hose long enough to allow you to stand to one side.

4. Seat – See *Seat Adjustments* on page 15 and *Service Position* on page 20.
5. Position Steering Levers – Remove eccentric spacers and rotate steering levers to the operating position. Reinstall spacers. Tighten hardware securely. See *Aligning the Steering Levers* (Figure 14) on page 25.

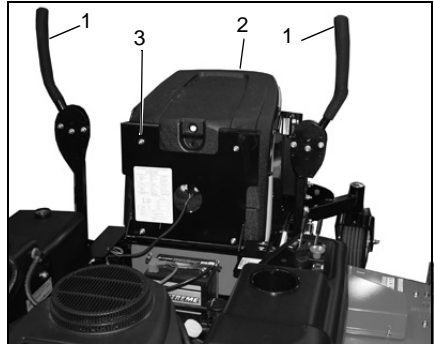

1. Steering Levers
2. Seat
3. Mounting Hardware

Figure 3

OF4110

6. Battery – Remove battery from unit and charge (See *Battery* on page 23).
7. Check Engine Crankcase – Check and add oil if needed. See Engine Manual for specifications.
8. Fill Engine Fuel Tank – Fill fuel tank. DO NOT OVERFILL! See *Filling Fuel Tank* on page 16.

**NOTE:** See engine manual for fuel type.

9. Hardware – Check for loose hardware.
10. Check Safety Interlock System – Check to see that the interlock system operates correctly (See *Safety Interlock System* on page 14).



**WARNING: FAILURE OF INTERLOCK** together with improper operation can result in severe personal injury.

11. Lubrication – Lubricate all fittings per maintenance label under seat and check hydrostat oil level (See *Lubricate Unit* on page 24).
12. **On 60-inch Decks:** Remove the discharge chute from the transport position and place the discharge chute in the operating position.
13. Level Deck – Check unit to ensure deck level set at factory has been maintained (See *Leveling the Mower Deck* on page 30).
14. Check Function of all Controls – Ensure unit runs and performs properly.



**WARNING: FAILURE OF CONTROLS** could result in death or serious injury.

## CONTROLS AND FEATURES

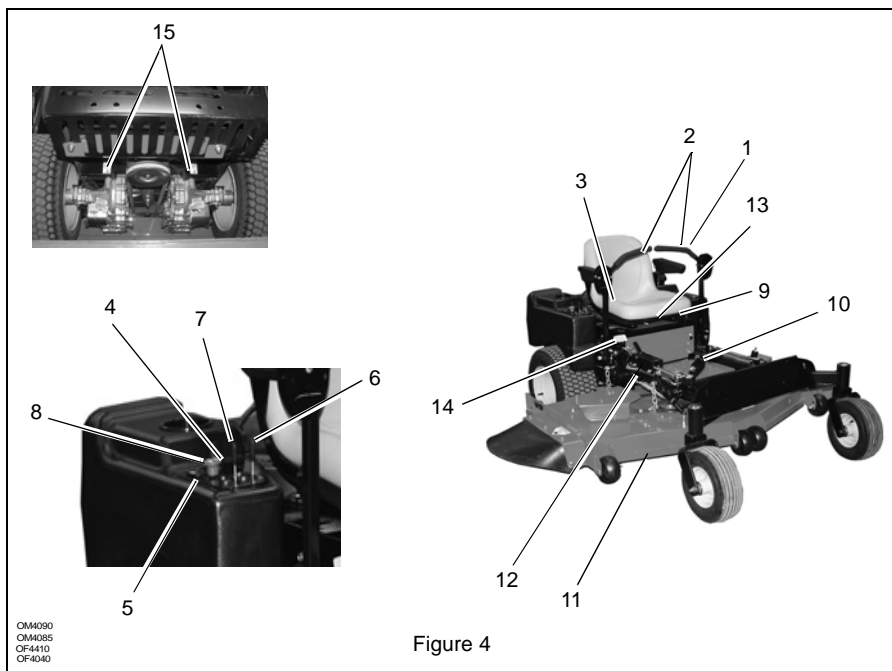

Figure 4

1. Fuel Tank and Cap
2. Steering Levers
3. Hydraulic Oil Reservoir
4. Ignition Switch
5. Hour Meter
6. Throttle Lever
7. Choke Control
8. Power Take Off (PTO) Switch

9. Battery
10. Mower Lift Pedal
11. Mower Deck
12. Mower Lift Lock
13. Seat Adjustment Lever
14. Parking Brake
15. Bypass Valve Lever

# OPERATION



**WARNING: AVOID INJURY.**  
Read and understand entire  
Safety section before proceeding.

## CONTROLS AND FEATURES

See Figure 4 for Controls and Features locations.

### Safety Interlock System



**WARNING:** Safety interlock system failure and improper operation of unit can result in death or serious injury. Test this system each time the unit is operated. If this system does not function as described, do not operate until repairs are made.

Perform the following tests to ensure the safety interlock system is working properly. If the unit does not perform as stated, contact your Gravely dealer for repairs.

**NOTE:** When the parking brake is engaged, the steering levers are locked in neutral.

Test	Steering Levers	PTO	Parking Brake	Engine
<b>STARTING INTERLOCK</b>				
1	Neutral	Off	Engaged	Starts
2	Neutral	On	Engaged	Doesn't Start
3	Neutral	Off	Dis-engaged	Doesn't Start
<b>OPERATING INTERLOCK (ENGINE ON)</b>				
4*	Neutral	On	Engaged	Shuts Off
5*	Neutral	Off	Dis-engaged	Shuts Off
* Operator lifts off seat.				

### Parking Brake Interlock System

With the parking brake engaged, the steering levers must be locked in neutral.

With the parking brake disengaged, the engine must not start and the engine must shut off if the operator leaves the seat.

### Steering Levers

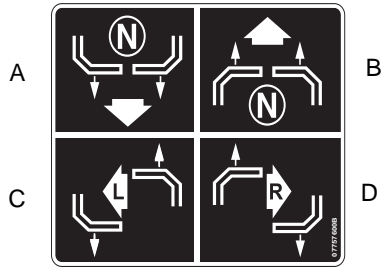

The steering levers control speed and direction. In addition, they will stop the unit.

- For reverse travel, pull both steering control levers backward.
- For straight forward travel, push both steering control levers forward.
- To turn left, pull the left back or push the right steering control lever forward or a combination of both.
- To turn right, pull the right back or push the left steering control lever forward or a combination of both.

To stop, return both steering levers to neutral.

**NOTE:** The steering controls are mechanically locked in neutral whenever the parking brake is engaged.

**NOTE:** Aggressive turning can scuff or damage lawns. ALWAYS keep both wheels rotating when making sharp turns. DO NOT make turns with inside wheel completely stopped. To obtain minimum turning radius, slowly reverse inside wheel while moving outside wheel slowly forward.

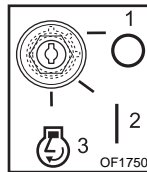

### Ignition Switch

Operate the ignition switch with the removable key. The switch has three positions: Off (1), On (2) and Start (3). To start the engine, turn the key to Start, then release to On. To stop the engine, turn the key to Off.

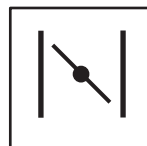

### Choke Control

Push the choke lever forward to start a cold engine. Pull the choke lever to the rear when the engine gets warm.



**Throttle Lever**  
 The throttle lever changes the engine speed. Move the throttle lever to Fast (1) to increase engine speed. Move the lever to Slow (2) to decrease engine speed.

**Cutting Height:**  
 Put cutting height adjustment pin in desired hole. Push mower lift pedal forward and hold it while pushing down on the lift lock. Slowly lower mower lift pedal until deck lift contacts cutting height adjustment pin.

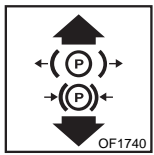

**Parking Brake Lever**  
 1. Pull lever up to engage parking brake.  
 2. Push lever down to disengage parking brake.

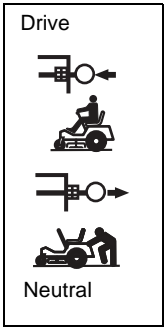

**Bypass Valve Lever**  
 Pull the lever back to set the pump in neutral and move the unit with the engine off.  
 Push the lever in to set the pump in the drive position and operate the unit.

**Seat Adjustments**

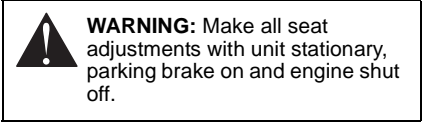

**WARNING:** Make all seat adjustments with unit stationary, parking brake on and engine shut off.

To adjust seat forward or backward:  
 1. While seated, pull seat adjustment lever outward and slide seat into desired position.  
 2. Release lever and slide seat forward or back to lock seat into position.

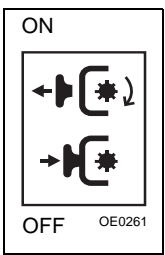

**Power Take Off (PTO) Switch**  
 Power take off (PTO) switch engages and disengages the mower blades.  
 Pull the power take off (PTO) switch to "On" position to engage mower blades.  
 Push the power take off (PTO) switch to "Off" position to disengage mower blades.

**Hour Meter**

Press and release the toggle button to shift between different functions.  
 Press and hold the toggle button to reset the timer or clear a service message.  
 The hour meter has three functions:  
**Hour Meter:** measures the amount of time the engine has been run. This time cannot be cleared.

**Timer (TMR1):** measures the time spent on individual jobs.  
 Press and hold the toggle button to reset the timer to zero. TMR1 will then start measuring engine run time until it is reset to zero again.

**Service Alert (Chg Oil, Chg H Oil & Filter, SVC Airfilter):** reminds operators of the maintenance interval for changing the engine oil, changing the hydraulic oil and filter and servicing the air filter.

The alert starts counting down two hours before the maintenance is due. The meter flashes the word, "Now," when it reaches the maintenance time.

Press and hold the toggle button to reset the maintenance clock to zero after performing the service.

**Mower Lift Pedal**



Mower lift pedal raises and lowers mower deck for mowing or transport.  
 Transport:  
 Push mower lift pedal all the way forward until lift lock engages.

**NOTE:** The hour meter is preprogrammed for the initial oil change at 25 hours and for 100 hours thereafter. The hour meter is programmed for the initial hydraulic oil and filter change at 75 hours and for 400 hours thereafter.

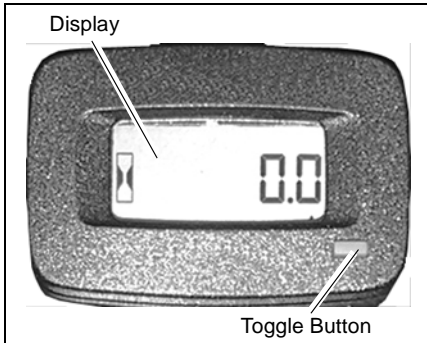

## FILLING FUEL TANK



**WARNING: AVOID INJURY.**  
Read and understand entire  
*Safety* section before proceeding.

Add fuel to Fuel Tank as needed. See your Engine Manual for correct type and grade of fuel.

### To add fuel to the fuel tank:

1. Clean fuel caps and surrounding area to prevent dust, dirt, and debris from entering fuel tanks.
2. Remove fuel caps.

**IMPORTANT:** Refer to Engine Manual for correct type and grade of fuel.

3. Fill fuel tank to the bottom of filler neck. See *Specifications* on page 33 for fuel tank capacity.

**IMPORTANT: DO NOT OVERFILL!** This equipment and/or its engine may include evaporative emissions control system components, required to meet EPA and/or CARB regulations, that will only function properly when the fuel tank has been filled to the recommended level. Overfilling may cause permanent damage to evaporative emissions control system components. Filling to the recommended level ensures a vapor gap required to allow for fuel expansion. Pay close attention while filling the fuel tank to ensure that the recommended fuel level inside the tank is not exceeded. Use a portable gasoline container with an appropriately sized dispensing spout when filling the tank. Do not use a funnel or other device that obstructs the view of the tank filling process.

4. Replace fuel cap and tighten.
5. ALWAYS clean up spilled fuel.

## GASOLINE

**IMPORTANT:** ALWAYS use gasoline that meets the following guidelines:

- Clean, fresh gasoline.
- A minimum of 87 octane/87 AKI (91 RON). High altitude use may require a different octane. Consult your engine manual.
- Gasoline with up to 10% ethanol (gasohol) or up to 10% MTBE (methyl tertiary butyl ether) is acceptable.
- Use of any gasoline other than those approved above will void the engine warranty. If the pumps are not marked for the content of alcohol or ethers, check ethanol and MTBE levels with the fuel supplier.
- Do not modify the fuel system to use different fuels.
- Never mix oil and gasoline.

**NOTE:** All gasoline is not the same. If the engine experiences starting or performance problems after using a new gasoline, switch to a different fuel provider or fuel brand.

**IMPORTANT:** Excessively oxygenated or reformulated fuels (fuels blended with alcohols or ethers) can damage the fuel system or cause performance problems. If any undesirable operating problems occur, use a gasoline with a lower percentage of alcohol or ether.

### Fuel Stabilizer

Gasoline left in the fuel system for extended periods without a stabilizer will deteriorate, resulting in gum deposits in the system. These deposits can damage the carburetor and the fuel hoses, filter and tank. Prevent deposits from forming in the fuel system during storage by adding a quality fuel stabilizer to the fuel. Follow the recommended mix ratio found on the fuel stabilizer container.

## PRE-START



**CAUTION:** Make sure all hardware is tight, all safety devices are in place and all adjustments are made correctly.

### 1. Check Safety Interlock System

If this system does not function as described do not operate until repairs are made.

### 2. Check Air Cleaner

Check air filter for dirt. Clean as required. Follow Engine Manual Maintenance Schedule.



### 3. Check Engine Fuel and Crankcase Oil

Check and add fuel if required. Check that engine crankcase oil is full. Follow Engine Manual Maintenance Schedule.

### 4. Check Tire Pressure

See *Specifications* on page 33 for correct tire pressure.

### 5. Check Hydraulic Fluid Level

See *Check Hydraulic Fluid Level* on page 21.

### 6. Adjust Seat

Be sure all controls can be reached safely from operator's position.

### 7. Set Cutting Height

Make sure the deck is set to the correct cutting height.

## STOPPING IN AN EMERGENCY



**WARNING:** Operating unit on slopes may lead to loss of steering control. When operating on slopes be prepared to react to an emergency situation.

1. Return steering levers to neutral position.
2. Immediately set parking brake.
3. Turn off PTO and engine.

## STARTING AND SHUT OFF



**CAUTION:** Read entire Owner/Operator Manual, Clutch Manual, and Engine Manual first. DO NOT attempt to start engine at this time.

To start the engine:

1. Make sure the steering levers are in neutral.
2. Put the PTO switch in the "Off" position.
3. Engage parking brake.
4. If the engine is cold, move the choke control to the "On" position. If the engine is warm or hot, do not use choke.
5. Move the throttle to 3/4 "Fast" position. See Engine Manual for detailed instructions.
6. Put the ignition key in the switch and turn it to the "Start" position.
7. As soon as the engine starts, release the key.
8. Move the choke control to the "Off" position from the "Choke" position. Wait until the engine is running smoothly before operation.

To stop the engine:

1. Bring the steering levers to neutral. Disengage the PTO and engage the parking brake.
2. Move the throttle lever to the "Slow" position.
3. Turn the ignition key to the "Off" position.

## TO MOW WITH UNIT

Operate the unit only when seated in the operator's position.

1. Start the engine. Let the engine warm until it is running smoothly.
2. Release parking brake.



**WARNING:** Move the steering control levers slowly and keep the throttle control lever at slow speed until you learn how to operate the unit.

3. Bring the steering levers to neutral.
4. Slow the engine down to about 3/4 speed.
5. Turn ON the PTO switch to engage the mower.

**IMPORTANT:** Never engage the PTO if the mower is plugged with grass or other material. This may cause damage to the electric clutch.

6. Move throttle control to fast.
7. Move the steering levers forward to obtain a slow ground speed.
8. To disengage the mower, move the PTO switch to the "Off" position.
9. When you know how to operate the unit, select a speed appropriate to your mowing conditions.

## PARKING

To park the unit:

1. Bring the steering levers to neutral. Turn off PTO.
2. Move the throttle lever to the "Slow" position.
3. Engage the parking brake.
4. Lower the attachment.
5. Turn the ignition key to the "Off" position and remove the key.

## MOVING THE UNIT WITH THE ENGINE OFF

**IMPORTANT:** Never tow unit.

1. Shut OFF engine.
2. Place seat in the service position (See *Service Position* on page 20).
3. Pull the right and left bypass levers to the neutral position.



**WARNING:** Do not bypass transmission when on a slope.

4. Disengage parking brake.
5. Push unit to desired location.
6. Engage parking brake.
7. Push the right and left bypass levers to the drive position.

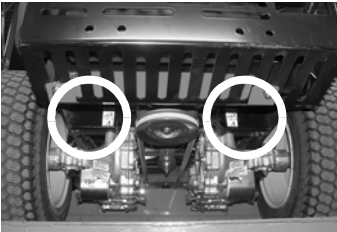

Push Lever In to Drive Position

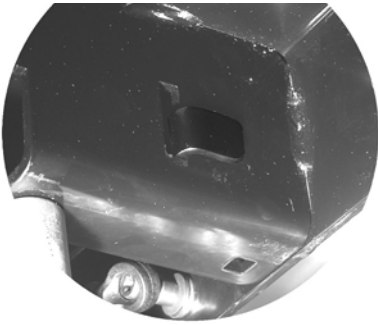

Pull Lever Out to the Neutral Position

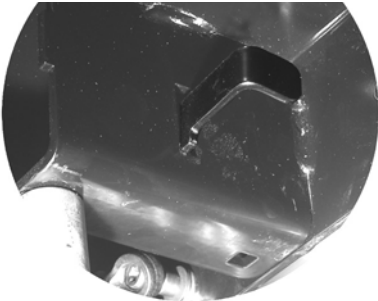

OF4105  
OF4110

Figure 5

## FOR BEST PERFORMANCE

Cut grass when it is dry.

Keep mower blades sharp.

Keep mower deck properly levelled.

Adjust anti-scalp rollers to prevent scalping.

Do not set height of cut too low. For very tall grass, mow twice.

Do not travel too fast.

Mow with the engine set at full throttle.

When mulching, only remove 1/3 of grass length per cutting. Do not cut more than 1 inch (2.54 cm) at any one time.

Discharge clippings into areas already cut.

Vary cutting pattern with each mowing.

Do not allow grass or debris to collect inside of mower deck. Clean after each use.

# MAINTENANCE SCHEDULE



**WARNING: AVOID INJURY.**  
Read and understand entire  
*Safety* section before proceeding.

Proper maintenance can prolong the life of unit. The following charts show the recommended service schedule. More frequent service may be required due to working conditions (heavy loads, high ambient temperatures, dusty conditions, or airborne debris).

See the maintenance instructions in the Engine Manual for additional information.

Period	Service	Task
<b>Each Use</b>	Check Safety Interlock	<b>WARNING:</b> Safety interlock system failure and improper operation of unit can result in death or serious injury. Test this system each time the unit is operated. If this system does not function as described, do not operate until repairs are made. See <i>Safety Interlock System</i> on page 14.
	Check Parking Brake Interlock System	See <i>Parking Brake Interlock System</i> on page 14.
	Check Hydraulic Fluid	Check hydraulic oil level mark on cap/dipstick. Add 20W50 engine oil as needed. Do not overfill. See <i>Check Hydraulic Fluid Level</i> on page 21.
	Check Tires	See <i>Specifications</i> on page 33 for correct tire pressure. <b>CAUTION:</b> Avoid injury! Explosive separation of tire and rim parts is possible when they are serviced incorrectly: <ul style="list-style-type: none"> <li>• Do not attempt to mount a tire without the proper equipment and experience to perform the job.</li> <li>• Do not inflate the tires above the recommended pressure.</li> <li>• Do not weld or heat a wheel and tire assembly. Heat can cause an increase in air pressure resulting in an explosion. Welding can structurally weaken or deform the wheel.</li> <li>• Do not stand in front or over the tire assembly when inflating. Use a clip-on chuck and extension hose long enough to allow you to stand to one side.</li> </ul>
	Clean Unit	Clean engine, battery, seat, mower deck, etc. of dirt and debris. Do not use solvents, hard cleaners, or abrasives. <b>IMPORTANT:</b> Do not spray the unit with water, especially when the unit is warm from operation. Water can seep into bearings and damage them. <b>NOTE:</b> Protect painted surfaces with automotive type wax.

Period	Service	Task
Each Use	Follow Engine Manual Maintenance Schedule	Perform scheduled engine maintenance. Refer to engine manual for detailed instructions.
Every 25 Hours	Check Mower Blades	Check mower blades for wear. Sharpen or replace as needed. See <i>Mower Blades</i> on page 22.
Every 50 Hours	Check Air Filter	Check air filter for dirt. Clean as required. Follow Engine Manual for maintenance schedule.
	Lubricate Unit	Oil all pivot points and pin connections. Grease lube fittings. See <i>Lubricate Unit</i> on page 24.
	Check Brake Gap	Adjust gap if necessary. See <i>Adjusting the Parking Brake</i> on page 26.
Every 100 Hours	Clean Battery	Keep battery and its terminals clean. See <i>Clean Battery</i> on page 23.
	Check Fasteners	Check mower blade mounting hardware and all other fasteners. Replace missing or damaged fasteners. Tighten all nuts and bolts to their correct torque value.
	Check Belts	Replace worn or deteriorated belts. See <i>Replacing Mower Belts</i> on page 27 and <i>Replacing the Hydro Pump Belt</i> on page 28.
Every 400 Hours	Change Hydraulic Fluid and Filter*	Drain hydraulic fluid tank, replace hydraulic oil filter, refill system. See <i>Hydraulic Fluid</i> on page 21.

\*Change hydraulic fluid and filter after the first 75 hours of operation and then every 400 hours.

## SERVICE AND ADJUSTMENTS

Gravely Dealers will provide any service which may be required to keep your unit operating at peak efficiency. Should engine service be required, it can be obtained from a Gravely Dealer or the engine manufacturer's authorized service center.



**WARNING: AVOID INJURY.**  
Read and understand entire *Safety* section before proceeding.



**CAUTION: HOT SURFACES**  
may result in injury. DO NOT touch engine or drive parts which are hot from operation. Allow parts to cool before servicing.

### SERVICE POSITION

1. Place unit on a flat level surface.  
ALWAYS stop engine. Ensure unit is secure and will not tip over. Strap and clamp onto lift if used.
2. Place steering levers in neutral and engage parking brake.
3. Remove wing knob.
4. Tip seat forward (Figure 6).



**CAUTION:** Be sure footing is secure to accommodate weight shift of seat when rotating it into service position.

5. When service is complete, lower seat and secure with wing knob or hex nut.

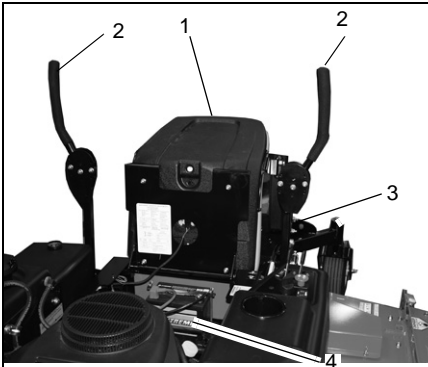

- |                     |                  |
|---------------------|------------------|
| 1. Service Position | 3. Parking Brake |
| 2. Steering Levers  | 4. Battery       |

Figure 6

OF4110

## HYDRAULIC FLUID



**WARNING:** HYDRAULIC FLUID can result in severe burns. Fluid in hydraulic system can penetrate skin and result in serious injury or death.

Be sure to stop the engine before doing any work on hydraulic parts.

Keep body and hands away from pin holes or nozzles which expel hydraulic fluid when under pressure. Use paper or cardboard, not hands, to search for leaks.

Ensure all hydraulic fluid connections are tight and all hydraulic hoses and lines are in good condition before applying pressure to system.

**FOREIGN FLUID INJECTED INTO BODY** can result in gangrene. Fluid must be surgically removed within a few hours by a doctor familiar with this form of injury.

## Check Hydraulic Fluid Level

Check the system with the unit cold and parked on a flat, level surface.

Then run the unit for about one minute and recheck the levels.

## To Add Hydraulic Fluid:

1. Remove the cap from the expansion tank.
2. Fill the expansion tank with 20W-50 engine oil with an SL API classification until oil level reaches the cold fill line on the tank.
3. Install the expansion tank cap and then purge the system. See *Purging the Hydraulic System* on page 22.

The hydraulic fluid should be at the cold fill line of the expansion tank.

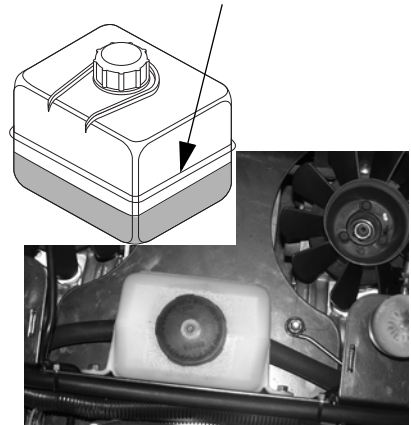

Figure 7

## Change Hydraulic Fluid and Filter

**NOTE:** Change hydraulic fluid and filter after the first 75 hours of operation and then every 400 hours. Use 20W-50 engine oil with an SL API classification.

1. Place container under oil filter to catch oil.
2. Remove the filter guard and oil filter from the transaxle.
3. Remove the oil drain plug or fitting from the inlet port and allow the transaxle to drain completely.
4. Clean the filter mounting surface and then lubricate rubber gasket on new oil filter with clean hydraulic oil.
5. Spin new oil filter onto filter housing until it makes contact. Tighten oil filter another 3/4 turn.
6. Install the filter guards removed in step 2. Tighten the mounting screws to 65 lbf-in (7.3 N•m).

7. Fill with 20W-50 engine oil with an SL API classification until oil appears at the bottom of the drain plug (about 2 quarts per transaxle). Install the drain plug and tighten it to 180 lbf-in (20.3 N•m).
8. Repeat steps 1 – 7 for the other transaxle.
9. Follow the instructions in *To Add Hydraulic Fluid*: on page 21.

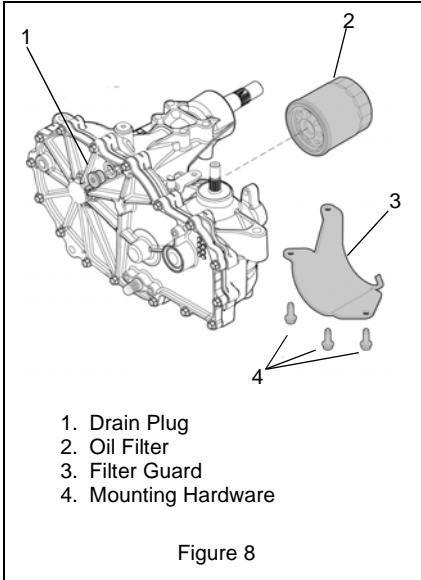

1. Drain Plug
2. Oil Filter
3. Filter Guard
4. Mounting Hardware

Figure 8

## Purging the Hydraulic System



**WARNING:** This adjustment requires operating the engine. Use extreme care to avoid contact with moving parts and hot surfaces. Be sure rear of unit is well supported and secure before starting engine.

1. With the unit up to and facing a wall, jack up the unit so that both drive wheels are off the ground.
2. Disengage the parking brake and put the transaxle bypass levers in the neutral position. See *Moving the Unit with the Engine Off* on page 18.
3. Start the engine and slowly move the steering levers in forward and reverse five or six times.
4. Stop the engine and put the transaxle bypass levers in the drive position. See *Moving the Unit with the Engine Off* on page 18.

5. Start the engine and slowly move the steering levers in forward and reverse five or six times.
6. Stop the engine, check the oil level and add oil as needed.
7. Repeat steps 2 – 6 until the transaxles operate smoothly in forward and reverse at normal speeds without excessive noise.

## MOWER BLADES

### Remove



**CAUTION:** Use sturdy gloves or padding to protect hands when working with mower blades.

1. Turn the engine off. Remove the ignition key. Remove the ignition wire from the spark plugs.
2. Remove the bolts, cup washer, and blades from the spindle shafts.

### Replace

1. Put the blades, cup washers, and the bolts back on the spindle shafts.
2. Tighten the bolts to a torque of 115 – 160 lbf-ft (156 – 217 N•m).
3. Replace the ignition wire on the spark plugs.

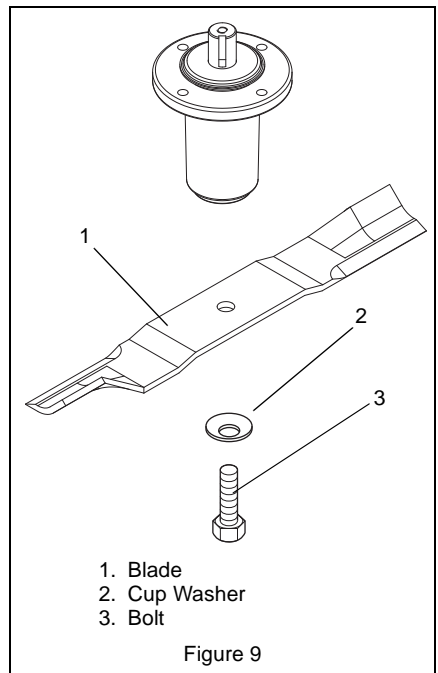

Figure 9

## Sharpen the Mower Blades



**CAUTION:** DO NOT sharpen mower blades while on unit. An unbalanced mower blade will cause excessive vibration and eventual damage to unit. Check mower blade balance before reinstalling blades.  
NEVER weld or straighten bent blades.

1. Remove mower blade from unit.

Discard mower blade if:

- More than 1/2 in. (1.27 cm) of metal is removed.
  - Air lifts become eroded.
  - Blade is bent or broken.
2. Sharpen mower blade by removing an equal amount of material from each end of mower blade. DO NOT change angle of cutting edge or round the corner of the mower blade.
  3. Check mower blade balance. Slide mower blade on an unthreaded bolt. A balanced blade should remain in a horizontal position. If either end of mower blade moves downward, sharpen the heavy end until blade is balanced.
  4. Install mower blade(s) on unit.
  5. Tighten the bolts to a torque of 115 – 160 lbf-ft (156 – 217 N•m).

DO NOT Sharpen to This Pattern

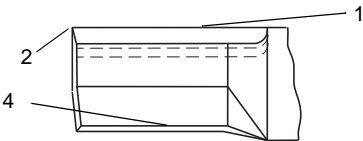

DISCARD if more than 1/2 in. (1.27 cm)

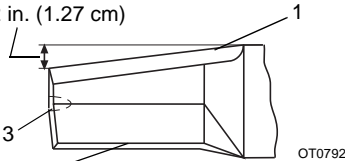

- OT0792
- Sharpen to this pattern
- |                  |             |
|------------------|-------------|
| 1. Cutting Edge  | 3. Air Lift |
| 2. Square Corner | Erosion     |
|                  | 4. Air Lift |

Figure 10

## BATTERY



**WARNING:** AVOID INJURY. Read and understand entire *Safety* section before proceeding.



**WARNING:** Battery posts, terminals and related accessories contain lead and lead compounds, chemicals known to the State of California to cause cancer and reproductive harm. Wash hands after handling.

Unit comes equipped with a maintenance-free battery that requires no regular maintenance except cleaning the terminals.

### Remove Battery

1. Shut OFF engine. Engage parking brake. Remove the ignition key.
2. Place seat in the service position (See *Maintenance Schedule* on page 19).
3. Disconnect cables from battery (negative, then positive) (Figure 11).
4. Remove hold down and remove battery.

### Replace Battery

1. Replace battery and secure with battery hold down.
2. Reconnect cables to battery (positive, then negative). Position boot over positive terminal.
3. Return seat to operating position.

### Clean Battery

Keep battery and its terminals clean. Inspect every 100 operating hours or monthly for best performance.

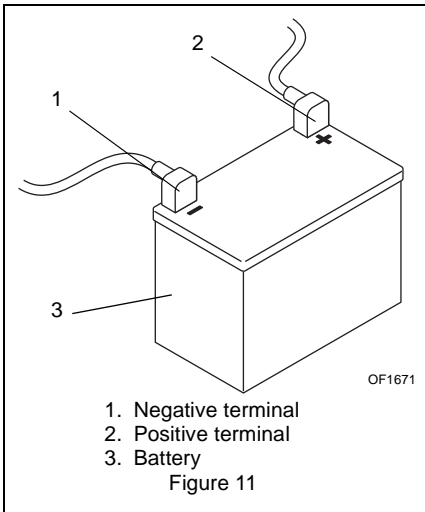

1. Remove battery from unit. See *Remove Battery* on page 23.
2. Clean terminals and battery cable ends with wire brush.
3. Coat terminals with dielectric grease or petroleum jelly.
4. Replace battery. See *Replace Battery* on page 23.

## Charging the Battery

### Battery Electrolyte First Aid

Follow First Aid directions for contact with battery fluid.

- External Contact: Flush with water.
- Eyes: Flush with water for at least 15 minutes and get medical attention immediately!
- Internal Contact: Drink large quantities of water. Follow with Milk of Magnesia, beaten egg or vegetable oil. Get medical attention immediately!

In case of internal contact, DO NOT induce vomiting!

**IMPORTANT:** DO NOT fast charge. Charging at a higher rate will damage or destroy battery. ONLY use an automatic charger designed for use with your battery.

ALWAYS follow information provided on battery by battery manufacturer. Contact battery manufacturer for extensive instructions to charge battery.

1. Remove battery from unit. See *Remove Battery* on page 23.
2. Place battery on bench or other well-ventilated place.

3. Connect positive (+) lead of charger to positive (+) terminal, and negative (-) lead to negative (-) terminal.
4. Charge battery according to charger and battery manufacturers' instructions.
5. Replace battery. See *Replace Battery* on page 23.

## Jump-Starting

Gravely does not recommend jump-starting your unit. Jump-starting can damage engine and electrical system components. See your engine manual for more detailed information.

## LUBRICATE UNIT

Apply oil at all pivot points and pin connections.

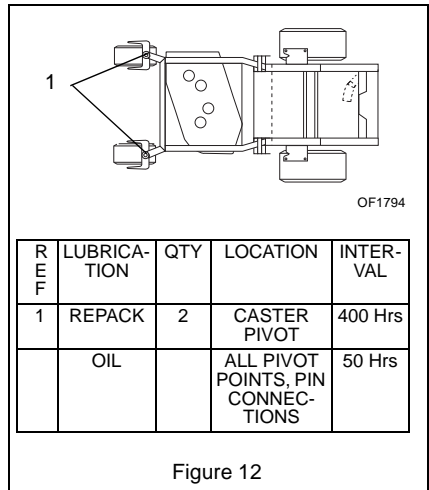

## STEERING CONTROL NEUTRAL ADJUSTMENT

### Eliminating Excessive Creeping of the Unit (Figure 13)



**WARNING:** This adjustment requires operating the engine. Use extreme care to avoid contact with moving parts and hot surfaces. Be sure rear of unit is well supported and secure before starting engine.

1. If hydraulic system is cold, run unit for a minimum of five minutes, then shut OFF engine.
2. With the unit up to and facing a wall, jack up the unit so that both drive wheels are off the ground.
3. Remove the drive wheels from the unit.



4. Start the engine, run engine at full throttle, and release the parking brake.
5. Move the steering levers from Forward to Reverse several times to make sure controls are free. Then return steering levers to neutral position.
6. Check wheel(s) for movement.

**NOTE:** The right and left hydraulic pumps are adjusted the same way.

7. If a wheel moves, adjust the return to neutral mechanism on the hydraulic pump:
  - a. Loosen the return to neutral screw on the pump.
  - b. Slowly move the speed and direction control bracket clockwise or counterclockwise until the wheel stops moving.
  - c. Hold the stop bracket in position and tighten the return to neutral screw on the pump.
8. Move steering levers from Forward to Reverse several times and return steering levers to neutral position. Check wheel(s) for movement.
9. If wheel is still moving, repeat steps 7 and 8.
10. Shut OFF engine.
11. Replace drive wheels.

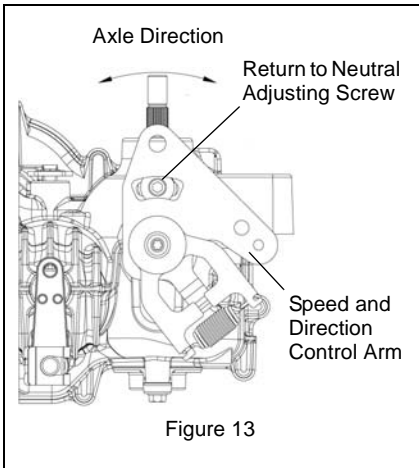

### Aligning the Steering Levers (Figure 14)

1. Shut OFF engine. Engage parking brake. Remove the ignition key.
2. Place seat in the service position (See *Service Position* on page 20).
3. Loosen brake interlock on the same side as steering lever to be adjusted.
4. Loosen tie rod jam nuts and turn tie rod until steering levers are aligned.
5. Tighten jam nut on tie rod, tighten brake interlock.

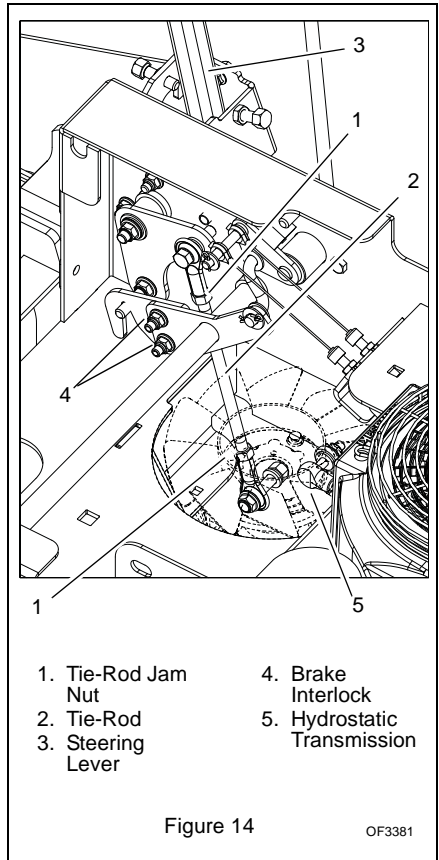

OF3381

## ADJUSTING THE UNIT TO TRACK STRAIGHT



**WARNING:** Prior to adjusting the tracking of the unit, shut OFF engine, engage parking brake, and remove the ignition key.

Check and adjust tire pressure. Increase pressure on side unit tracks to. **DO NOT** exceed maximum recommended tire pressure (See *Specifications* on page 33). If tire pressure adjustment does not solve tracking problem, adjust the limiter bolts on the stop bracket (Figure 15). Front bolts adjust forward and rear bolts adjust reverse. Lengthen the limiter bolt (move closer to lever) on side which is too fast.

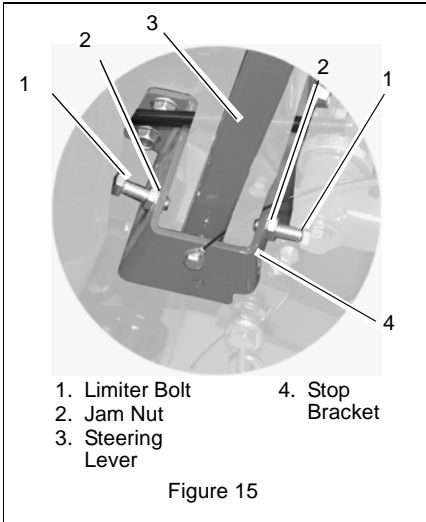

## ADJUSTING THE HEIGHT OF THE STEERING LEVER HANDLES

The handles have three height positions (Figure 16).

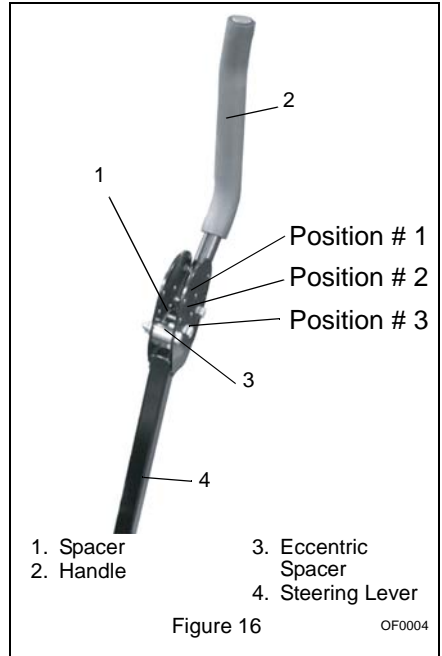

1. Shut OFF engine. Engage parking brake. Remove the ignition key.
  2. Remove the spacer, handle, and eccentric spacer from the steering lever.
- NOTE:** Position the right and left handles at the same height position.
3. Install the spacer, handle, and eccentric spacer in the appropriate height position. Do not tighten the nut holding the eccentric spacer.
  4. Turn the eccentric spacer until the right and left handles are the same height. Tighten nut.

## ADJUSTING THE PARKING BRAKE

The parking brake should not need adjustment, however if the parking brake does not hold the unit properly, the brake may need adjustment.

## Check Adjustment

**NOTE:** Be sure to check the parking brake on both sides of the unit (Figure 17).

1. Engage parking brake and set both transmission bypass valves to the neutral position. See *Moving the Unit with the Engine Off* on page 18.
2. Push the unit forward.  
If the unit easily rolls forward the transmission brakes are not fully engaging. Tighten the brake cable to fully engage the brake lever on the transmission.

## Adjust the Parking Brake

1. Disengage the parking brake.
2. Loosen the nuts on the parking brake cable adjuster and then turn the adjuster until the cable is taut, not tight.
3. Engage the parking brake and check the adjustment. Repeat as needed.
4. Tighten the nuts.

**NOTE:** Set both bypass valves to the drive position when finished adjusting the brake.

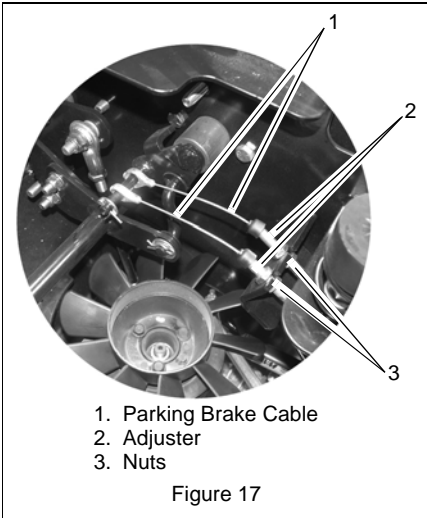

## PTO BELT



**WARNING:** MOVING PARTS can cut or amputate body parts. ALWAYS wait for moving parts to stop before performing maintenance or service.



**CAUTION:** DAMAGED OR WORN BELTS may result in injury and/or damage to unit. Check belts for excessive wear or cracks often.

## PTO Belt Access

1. Properly stop and park unit (See *Operation* on page 14).
2. Lower the mower.
3. Place seat in most rearward position.
4. Remove belt covers.
5. Place foot board in open position (Figure 18).

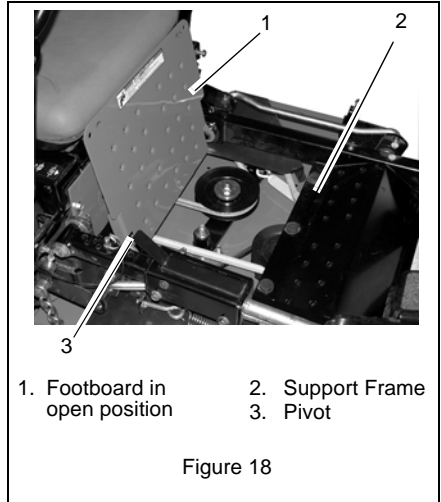

## Replacing Mower Belts

**NOTE:** Long mower belt must be removed to remove short mower belt.



**CAUTION:** Use care when releasing idler spring tension. Keep body parts well away from idlers when performing this operation.

1. Slowly release the tension on the long mower belt idler until all the tension is removed from the springs.
2. Remove long mower belt from left blade spindle and remove from deck.
3. Slowly release the tension on the short belt idler until all the tension is removed from the springs.

- Remove short mower belt from right blade spindle and from deck. Idler pivot bolt must be loosened slightly to gain clearance to remove belt from under idler pulley (Figure 19).
- Arrange new mower belt(s) on deck (short belt first). Retighten short mower belt idler pivot bolt. Install belts on sheaves. Put belts onto center sheave last.

**NOTE:** The PTO idler spring length range is 12.25 – 12.5 in. (31 – 31.8 cm) measured at a 3 in. (7.62 cm) cutting height. Adjust the idler spring length as needed, see Figure 20.

- Replace belt covers and return foot board to closed position.

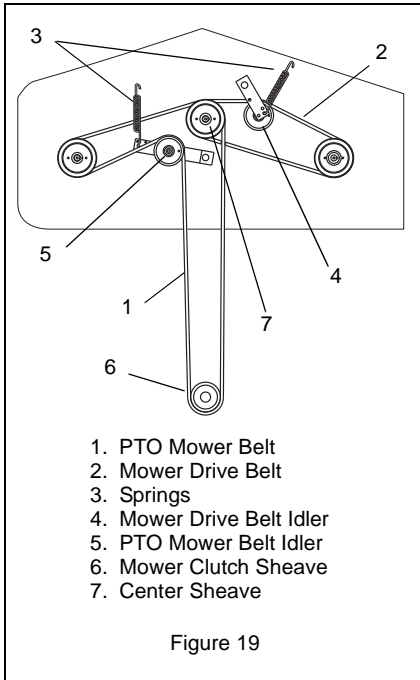
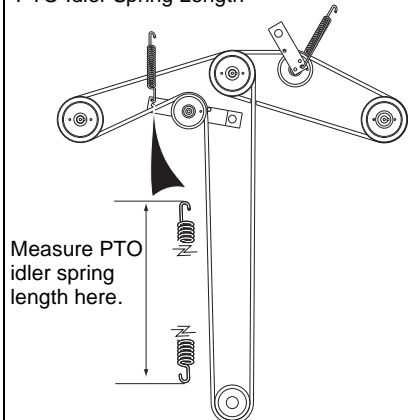

Figure 19

### PTO Idler Spring Length



The PTO idler spring length range is 12.25 – 12.5 in. (31 – 31.8 cm) measured at a 3 in. (7.62 cm) cutting height. Adjust as necessary.

Figure 20

OF4345

### Replacing the Hydro Pump Belt

- Properly stop and park unit (See *Operation* on page 14).
- Remove the PTO belt from the mower clutch sheave (See *Replacing Mower Belts* on page 27).



**CAUTION:** Use care when releasing idler spring tension. Keep body parts well away from idlers when performing this operation.

- Slowly release the tension on the hydro pump belt idler until all the tension is removed from the springs.
- Remove old hydro pump belt from right hand hydrostat sheave first (Figure 21).
- Install new hydro pump belt by positioning belt on sheaves. Put belt onto right hand hydrostat sheave last.
- Replace long mower belt on mower clutch sheave. See *Replacing Mower Belts* on page 27.

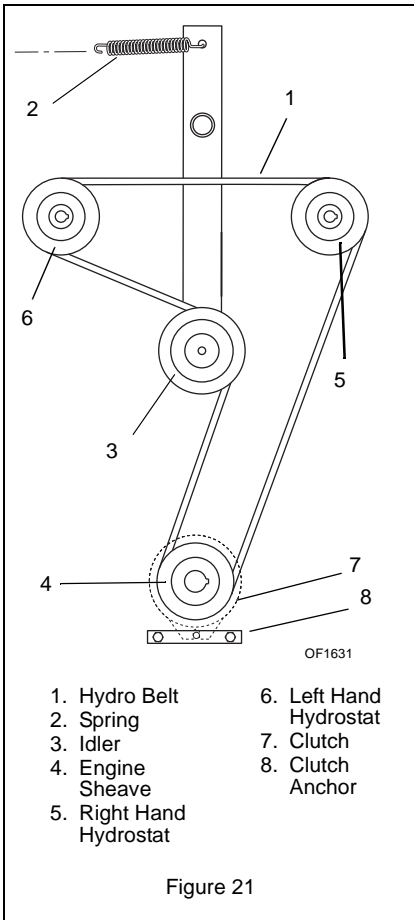

Figure 21

## MOWER DECKS

### Anti-scalp Roller Adjustment

The anti-scalp rollers are set at the factory for typical mowing height, but can be adjusted for high or low cutting conditions (Figure 22).

Anti-Scalp rollers are intended to prevent lawn scalping, not to control cutting height.

For a very high cutting height, set the anti-scalp rollers in the lowest position on the bracket.

For a very low cutting height, set the anti-scalp rollers in the highest position on the bracket.

**NOTE:** There are four anti-scalp rollers on the outside of the mower deck and four anti-scalp rollers on the inside of the mower deck. Make sure all anti-scalp rollers are set at the same height.

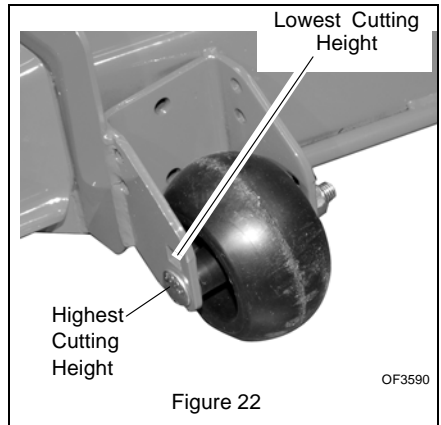

Figure 22

### Removing the Mower Deck

1. Remove PTO belt (See *Replacing Mower Belts* on page 27).



#### **WARNING:** AVOID INJURY.

Mower lift arms and mower lift pedal could cause severe injury if they are not locked before removing the mower deck. ALWAYS lock mower deck lift before removing the deck.

2. Lock the mower deck in the service position.  
Push the mower lift pedal forward between cutting height number 4 and number 5 to align the holes in the deck lift shaft and the deck lift cover. Insert the cutting height pin in the holes on the side of the deck lift cover so it passes all the way through the deck lift cover and shaft.

**IMPORTANT:** The mower lift arms are not locked unless the cutting height adjustment pin passes all the way through both the deck lift cover and shaft.

**NOTE:** Support the mower deck on blocks or jack stands before disconnecting link chains from mower lift arms to prevent the deck from falling.

3. Remove link chains from mower lift arms. Note hole location on mower lift arms for replacement.
4. Remove the mower mounting pins connecting the mower mounting arms to the deck.
5. Slide mower deck out from under unit.

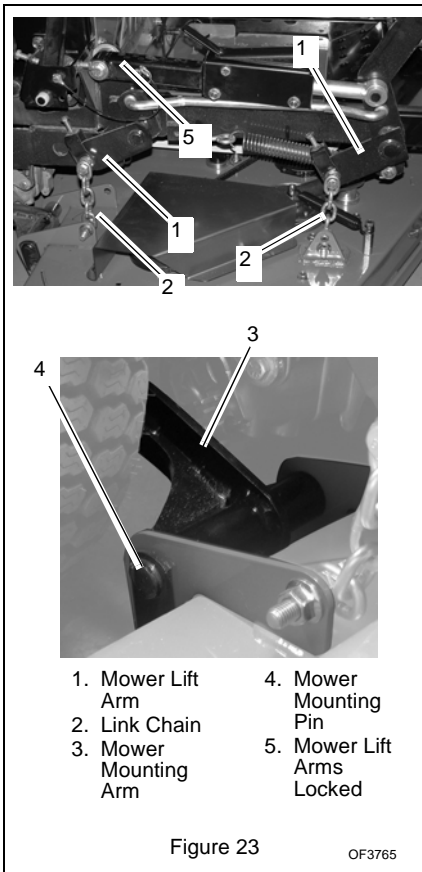

Figure 23

OF3765

### Installing the Mower Deck (Figure 23)

1. Slide mower deck under unit.
2. Connect mower mounting arms to deck with mower mounting pins.
3. Install link chains on the mower lift arms in the same holes they were removed from.
4. Install PTO mower belt (See *Replacing Mower Belts* on page 27).
5. Level mower deck (See *Leveling the Mower Deck* on page 30).

### Leveling the Mower Deck

These adjustments should be made on a level surface with the tires inflated to the correct air pressure.

### Check Blade Level and Pitch

1. Raise mower deck to a 3 in. (7.62 cm) cutting height.
2. Shut off engine. Engage parking brake. Remove the ignition key.

**NOTE:** Place blocks under the bottom edge of the deck, not under the reinforcement bar welded along deck face.

3. Place blocks at each corner of the deck to support the weight of the deck.
  4. Turn the blades so the blade ends point left to right across the width of the deck.
  5. Measure the distance between the ground and cutting edge of the blade on the left blade (Left position in Figure 24) and on the right blade (Right position in Figure 24). Distances should be within 3/16 in. (4.7 mm). If they are not, raise the low side of the deck using the height adjusters on the deck lift brackets (see Figure 25).
  6. After deck is level side to side, check the deck front to back pitch.
  7. Turn the blades so the blade ends point front to back as shown in Figure 24.
  8. Measure the distance between the ground and the cutting edge of the middle blade at the front of the deck (Front position in Figure 24) and between the ground the cutting edge of the left and right blades at the rear of the deck (Rear position in Figure 24).
  9. The cutting edge at the front of the deck (Front position in Figure 24) should be 1/8 in. (3.18 mm) lower than the cutting edges at the rear of the deck (Rear position in Figure 24).
  10. If measurements are out of range, raise the low side of the deck using the height adjusters on the deck lift brackets (see Figure 25). Be sure to raise the deck evenly to keep the deck level side to side.
- NOTE:** Pitching the front of the blades lower than the rear provides a balance between cut quality and the power needed to cut grass. Certain cutting conditions require the deck to be pitched with the rear of the blades lower than the front. Heeling the deck this way requires more engine power but can provide better cut quality.
11. Remove the blocks from under the deck.

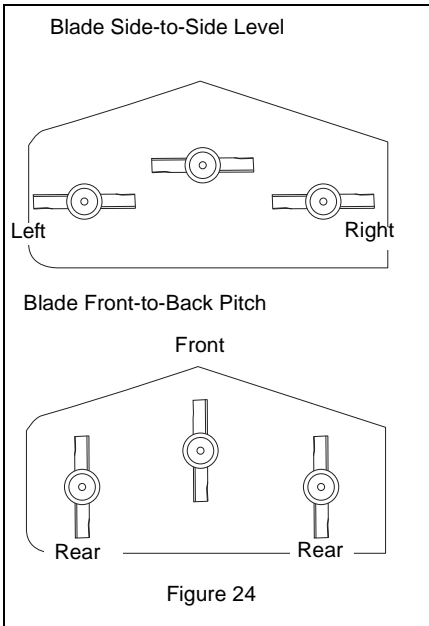

### Adjust Blade Height

Level and pitch the mower with the height adjusters on each deck lift bracket (Figure 25).

Loosen the jam nut on the deck lift bracket bolt about 1/4 turn to reduce clamp load on the height adjusters.

Loosen the jam nut on the deck adjuster bolt and then turn the bolt clockwise to raise the deck or counterclockwise to lower the deck. Tighten both jam nuts.

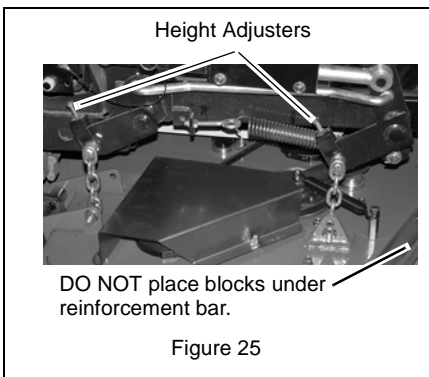

## CLUTCH ADJUSTMENT

If clutch fails to engage or disengage properly or begins to make abnormal noise, check the air gap adjustment at the three inspection slots.

To check:

1. Stop engine, remove key and wait for all hot parts to cool.
2. Measure the air gap between the armature and the rotor.  
Minimum: A .016" feeler gauge should slide between armature and rotor with slight contact.  
Maximum: A .020" feeler gauge should slide between armature and rotor with slight contact.
3. Repeat for each inspection slot.

To adjust:

1. If necessary, loosen gap adjustment nuts until a .016" feeler gauge fits between armature and rotor.
2. Slide a .020" feeler gauge between armature and rotor.
3. Tighten gap adjustment nut until there is slight contact on feeler gauge.
4. Repeat steps 1 – 3 at each inspection slot.

**NOTE:** Adjust air gap as evenly as possible.

5. Start unit, engage and disengage PTO.
6. Shut off unit.
7. Recheck air gap and adjust if needed.

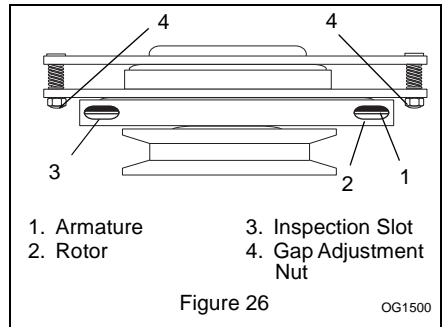

## STORAGE



**WARNING: AVOID INJURY.**  
Read and understand entire  
*Safety* section before proceeding.

### SHORT TERM

NEVER spray unit with high-pressure water or store unit outdoors.

Inspect unit for visible signs of wear, breakage or damage.

Keep all nuts, bolts and screws properly tightened and know unit is in safe working condition.

Store unit in a cool, dry protected area.

### LONG TERM

Clean unit thoroughly with mild soap and low pressure water and lubricate (See *Lubricate Unit* on page 24 in *Maintenance*). Touch up all scratched painted surfaces.

Remove weight from wheels by putting blocks under frame or axle.

When storing unit for extended periods of time, remove all fuel from tank and carburetor (run dry). Refer to Engine Manual.

Clean and charge the battery. Charge battery every three to four weeks when storing unit.

### Fuel System

Gasoline left in the fuel system for extended periods without a stabilizer will deteriorate, resulting in gum deposits in the system. These deposits can damage the carburetor and the fuel hoses, filter and tank. Prevent deposits from forming in the fuel system during storage by adding a quality fuel stabilizer to the fuel. Follow the recommended mix ratio found on the fuel stabilizer container.

To treat the fuel system for storage:

1. Add fuel stabilizer according to manufacturers' instructions.
2. Run engine for at least 10 minutes after adding stabilizer to allow it to reach the carburetor.

NEVER store the engine with fuel in the fuel tank inside of a building with potential sources of ignition.

### To Take the Unit Out of Storage

1. Refer to the engine service manual to prepare the engine for service.
2. Put fresh, clean fuel in the fuel tank.
3. Begin the maintenance schedule.
4. Charge and install the battery.

## ACCESSORIES

Part No.	Description
79100400	Mulching Kit 48-inch Decks
79206400	Mulching Kit 52-inch Decks
79206500	Mulching Kit 60-inch Decks
79206700	Striper Kit
79100700	Discharge Cover Kit 48-inch Decks
79100800	Discharge Cover Kit 52-inch Decks
79206800	Discharge Cover Kit 60-inch Decks
79202700	Headlight Kit
79102500	Bagger Adapter Kit 60-inch Decks
79102600	Bagger Adapter Kit 52-inch Decks
79102700	Bagger Adapter Kit 48-inch Decks
89100300	HD Series Bagger

## SERVICE PARTS

Part No.	Qty	Description
21547900	1	Fuel Filter (991082, 083, 084, 090)
21545700	1	Fuel Filter (991091)
21548000	1	Air Filter (991082, 083, 084, 090)
21545800	1	Air Filter (991091)
21545900	1	Air Pre-Cleaner (991091)
21397200	1	Engine Oil Filter (991091)
21548100	1	Engine Oil Filter (991082, 083, 084, 090)
21545100	2	Hydraulic Oil Filter
21547800	2	Spark Plug (991082, 083, 084, 090)
21544000	2	Spark Plug (991091)
07200025	1	PTO Belt – 48-inch Decks
07200026	1	PTO Belt – 52-inch Decks
07200028	1	PTO Belt – 60-inch Decks
07211500	1	Traction (Hydro Pump) Belt
00450200	1	Blade – 48-inch Decks
03253800	1	Blade – 52-inch Decks
03253900	1	Blade – 60-inch Decks



## SPECIFICATIONS

Model Number	991082	991083
<b>Model</b>	<b>HD 48</b>	<b>HD 52</b>
<b>Engine</b>	Kawasaki	
Engine Model Number	FR730	
Engine Displacement – in <sup>3</sup> (cc)	44.3 (726)	
Governed RPM (May be different from maximum RPM)	3,600 ± 75	
<b>Liquid or Air Cooled</b>	Air	
<b>Speed</b>		
Forward Maximum – mph (km/h)	8.0 (12.9)	
Reverse Maximum – mph (km/h)	4.0 (6.4)	
<b>Turning Radius</b>	Zero	
<b>Brakes</b>	Hydro – Parking	
<b>Electrical</b>		
Starter	Electric	
Battery	12-Volt Maintenance Free U1-250	
Power Take-Off	Electric PTO Clutch/Brake	
<b>Fuel</b>		
Fuel Type	Refer to Engine Manual	
Fuel Tank Capacity – gal. (L)	6.5 (24.6)	
<b>Transmission</b>		
Type	Hydrostatic Drive	
Transmission Oil	Use 20W-50 engine oil with an SL API classification	
Hydraulic Oil Filter	Yes	
<b>Size and Weight</b>		
Length – in. (cm)	71.5 (181.6)	
Width (With Chute Up) – in. (cm)	50 (127)	55.5 (141)
Height – in. (cm)	42 (106)	
Weight – lbs (kg)	823 (373.9)	832 (377.4)
<b>Tires</b>		
Front Tire Size – in.	13 x 5-6	
Rear Tire Size – in.	20 x 10-10	
Front Tire Pressure – psi (kPa)	20 – 25 (138 – 172)	
Rear Tire Pressure – psi (kPa)	15 – 18 (103 – 124)	
<b>Mower Deck</b>		
Mower Deck Lift	Mechanical	
Cutting Width – in. (cm)	48 (121.9)	52 (132.1)
Cutting Height – in. (cm)	1 – 5 (2.5 – 12.7)	
Cutting Height Increments – in. (cm)	0.5 (1.25)	

# SPECIFICATIONS

Model Number	991084	991090	991091
Model	HD 60	HD 44	HD 60
Engine	Kawasaki		Kohler
Engine Model Number	FR730	FR691	Courage Pro
Engine Displacement – in <sup>3</sup> (cc)	44.3 (726)		44.2 (725)
Governed RPM (May be different from maximum RPM)	3 600 ± 75		
Liquid or Air Cooled	Air		
Speed			
Forward Maximum – mph (km/h)	8.0 (12.9)		
Reverse Maximum – mph (km/h)	4.0 (6.4)		
Turning Radius	Zero		
Brakes	Hydro – Parking		
Electrical			
Starter	Electric		
Battery	12-Volt Maintenance Free U1-250		
Power Take-Off	Electric PTO Clutch/Brake		
Fuel			
Fuel Type	Refer to Engine Manual		
Fuel Tank Capacity – gal. (L)	6.5 (24.6)		
Transmission			
Type	Hydrostatic Drive		
Transmission Oil	Use 20W-50 engine oil with an SL API classification		
Hydraulic Oil Filter	Yes		
Size and Weight			
Length – in. (cm)	71.5 (181.6)		
Width (With Chute Up) – in. (cm)	62.8 (159.5)	46.8 (118.9)	62.8 (159.5)
Height – in. (cm)	42 (106)		
Weight – lbs (kg)	853 (386.9)	818 (373.3)	853 (386.9)
Tires			
Front Tire Size – in.	13 x 5-6		
Rear Tire Size – in.	20 x 10-10		
Front Tire Pressure – psi (kPa)	20 – 25 (138 – 172)		
Rear Tire Pressure – psi (kPa)	15 – 18 (103 – 124)		
Mower Deck			
Mower Deck Lift	Mechanical		
Cutting Width – in. (cm)	60 (152.4)	44 (111.8)	60 (152.4)
Cutting Height – in. (cm)	1 – 5 (2.5 – 12.7)		
Cutting Height Increments – in. (cm)	0.5 (1.25)		



# Consumer Mowing Equipment Limited Warranty

Ariens Company (Ariens) warrants to the **original purchaser** that Ariens, Gravely and Countax brand lawn and garden consumer products purchased on or after 1/1/2011 will be free from defects in material and workmanship for the time period noted in the chart below. Equipment put to personal use around a single household or residence is considered "Consumer Use"; equipment put to any business use (agricultural, commercial, or industrial) or used at multiple locations is considered "Commercial Use." If any product is rented or leased, then the duration of these warranties shall be 90 days after the date of purchase.

An authorized Ariens dealer (Ariens brand products), Gravely dealer (Gravely brand products), or Countax dealer (Countax brand products) will repair any defect in material or workmanship, and repair or replace any defective part, subject to the conditions, limitations and exclusions set forth herein. Such repair or replacement will be free of charge (labor and parts) to the original purchaser except as noted below.

Warranty Code	Product Group	Warranty Period Consumer Use	Warranty Period Commercial Use
HA	Zoom & ZT Zero-Turn Riders; AMP™ Rider	3 Years	90 Days
HB	Max Zoom & ZT HD Zero-Turn Riders	3 Years	1 Year
HC	Tractors, "961" Series Walk-Behind Mowers	2 Years	90 Days
HD	Classic LM Series Mowers; Wide Area Walk Mowers	3 Years	90 Days
N/A	Service (replacement) Parts	90 Days (no labor)	90 Days (no labor)

### Special Extensions

The chart below details special extensions to this warranty:

Warranty Code	Warranty Exception	Warranty Period	Use	Detail
HA, HB	Mower Deck Shell on Zero-Turn Riders	5 Years	Consumer	3 years parts and labor Additional 2 years parts only
HA, HB	Main Frame on Zero-Turn Riders	5 Years	Consumer	3 years parts and labor Additional 2 years parts only
HA	Batteries for AMP™ Rider	2 Years	Consumer	100% first year; prorated second year

### Exceptions and Limitations

The chart below details special exceptions to this warranty:

Warranty Code	Warranty Exception	Warranty Period	Use	Detail
All	Batteries	1 Year	Consumer	Prorated
All	Belts, Muffler, Tires	None	Commercial	These components are not covered when used commercially.
All	Cloth, Plastic, and Rubber Components (Including Belts and Cables)	Maximum 2 Years	All	Warranty is limited to 2 years for consumer use. Except as noted above, these components are covered for defect, not for wear.
All	Engines	See Engine Manufacturer's Warranty	All	Engines are covered by engine manufacturer's warranty. Refer to engine manufacturer's warranty statement.

## **Customer Responsibilities**

**Register the product immediately at the time of sale.** If the dealer does not register the product, the customer must complete the product registration card in the literature package and return it to the Ariens Company, or register the unit online at [www.ariens.com](http://www.ariens.com), [www.gravelly.com](http://www.gravelly.com), [www.countax.com](http://www.countax.com).

To obtain warranty service, the **original purchaser** must:

- Perform the maintenance and adjustments explained in the owner's manual.
- Promptly notify Ariens or an authorized Ariens, Gravelly or Countax service representative of the need for warranty service.
- Transport the product to and from the place of warranty service at owner's expense.
- Have the warranty service performed by an authorized Ariens, Gravelly or Countax service representative.

## **To Find an Authorized Service Representative:**

<b>In the U.S. and Canada:</b>		
Use the dealer locator on our websites: <a href="http://www.ariens.com">www.ariens.com</a> • <a href="http://www.gravelly.com">www.gravelly.com</a>		
Or contact us by mail or by phone:		
<b>In the U.S., Canada, Mexico, Caribbean, Central and South America:</b>	<b>In Europe, Asia, Africa or the Middle East:</b>	<b>In Australia or New Zealand:</b>
Ariens Company 655 W. Ryan Street Brillion, WI 54110 Phone: (920) 756 - 4688 <a href="http://www.ariens.com">www.ariens.com</a>	Countax Ltd, Countax House Great Haseley, Oxfordshire, OX44 7PF Phone: 0800 597 7777 <a href="http://www.countax.com">www.countax.com</a>	109-111 Abbot House Hallam, Victoria 3803 Australia Phone: (03) 9796 4244 1800 335 489 <a href="http://www.bynorm.com.au">www.bynorm.com.au</a>

## **Exclusions - Items Not Covered by This Warranty**

- Parts that are not genuine Ariens, Gravelly or Countax service parts are not covered by this warranty and may void the warranty.
- Damages resulting from the installation or use of any part, accessory, or attachment which is not approved by the Ariens Company for use with product(s) identified herein are not covered by this warranty.
- The following maintenance, service and replacement items are not covered by this warranty unless they are noted in the Limitations section above: lubricants, spark plugs, oil, oil filters, air filters, fuel filters, brake linings, brake arms, brake shoes, skid shoes, scraper blades, shear bolts, mower blades, mower vanes, brushes, headlights, light bulbs, knives, cutters.
- Any misuse, alteration, improper assembly, improper adjustment, neglect, or accident which requires repair is not covered by this warranty.
- **Use of gasoline blends exceeding 10% ethanol voids any and all warranties.**
- Products are designed to the specifications in the area that the product was originally distributed. Different areas may have significantly different legal and design requirements. This warranty is limited to the requirements in the area in which the unit was originally distributed. Ariens Company does not warrant this product to the requirements of any other area. Warranty service is limited to service within the area originally distributed.
- In countries other than the United States and Canada, contact the Ariens Company dealer for warranty policies that govern within your country. Rights may vary from country to country and within any one country.

## **Disclaimer**

Ariens Company may from time to time change the design of its products. Nothing contained in this warranty shall be construed as obligating the Ariens Company to incorporate such design changes into previously manufactured products, nor shall such changes be construed as an admission that previous designs were defective.

## **LIMITATION OF REMEDY AND DAMAGES**

Ariens Company's liability under this warranty, and under any implied warranty that may exist, is limited to repair of any defect in workmanship, and repair or replacement of any defective part. Ariens Company shall not be liable for incidental, special, or consequential damages (including lost profits). Some states do not allow the exclusion of incidental or consequential damages, so the above limitation or exclusion may not apply to you.

## **DISCLAIMER OF FURTHER WARRANTY**

Ariens Company makes no warranty, express or implied, other than what is expressly made in this warranty. If the law of your state provides that an implied warranty of merchantability, or an implied warranty of fitness for particular purpose, or any other implied warranty, applies to Ariens Company, then any such implied warranty is limited to the duration of this warranty. Some states do not allow limitations on how long an implied warranty lasts, so the above limitation may not apply to you.

*This warranty gives you specific legal rights, and you may also have other rights which vary from region to region.*

# CALIFORNIA AND EPA (UNITED STATES ENVIRONMENTAL PROTECTION AGENCY) EVAPORATIVE EMISSION CONTROL WARRANTY STATEMENT

## YOUR WARRANTY RIGHTS AND OBLIGATIONS

The CARB (California Air Resources Board), the EPA, and Ariens Company are pleased to explain the evaporative emission control system's warranty on your 2011 model year small off-road equipment. In California, new equipment that uses small off-road engines must be designed, built, and equipped to meet the State's stringent anti-smog standards. Ariens Company must warrant the evaporative emission control system on your small off-road equipment for the period listed below provided there has been no abuse, neglect or improper maintenance of your equipment.

Your evaporative emission control system may include parts such as: fuel tanks, fuel lines, fuel caps, valves, canisters, filters, vapor hoses, clamps, connectors, and other associated components.

## MANUFACTURER'S WARRANTY COVERAGE:

This evaporative emission control system is warranted for two years. If any evaporative emission-related part on your equipment is defective, the part will be repaired or replaced by Ariens Company.

## OWNER'S WARRANTY RESPONSIBILITIES:

- As the small off-road equipment owner, you are responsible for the performance of the required maintenance listed in your Owner's Manual. Ariens Company recommends that you retain all receipts covering maintenance on your small off-road equipment, but Ariens Company cannot deny warranty solely for the lack of receipts.
- As the small off-road equipment owner, you should however be aware that the Ariens Company may deny you warranty coverage if your evaporative emission control system part has failed due to abuse, neglect, or improper maintenance or unapproved modifications.
- You are responsible for presenting your small off-road equipment to an authorized Ariens, Gravely, or Parker service representative as soon as the problem exists. The warranty repairs should be completed in a reasonable amount of time, not to exceed 30 days. If you have a question regarding your warranty coverage, you should contact Ariens Company Technical Service Center at 1-920-756-4688.

## DEFECTS WARRANTY REQUIREMENTS:

- (a.) The warranty period begins on the date the small off-road equipment is delivered to an ultimate purchaser.
- (b.) General Evaporative Emissions Warranty Coverage. Ariens Company warrants to the ultimate purchaser and any subsequent owner that the evaporative emission control system when installed was:
  - (1.) Designed, built, and equipped so as to conform with all applicable EPA and CARB regulations; and
  - (2.) Free from defects in materials and workmanship that causes the failure of a warranted part for a period of two years.
- (c.) The warranty on evaporative emissions-related parts will be interpreted as follows:
  - (1.) Any warranted part that is not scheduled for replacement as required maintenance in the written instructions must be warranted for the warranty period defined in subsection (b)(2). If any such part fails during the period of warranty coverage, it must be repaired or replaced by the Ariens Company. Any such part repaired or replaced under the warranty must be warranted for a time not less than the remaining warranty period.
  - (2.) Any warranted part that is scheduled only for regular inspection in the written instructions must be warranted for the warranty period defined in subsection (b)(2). A statement in such written instructions to the effect of "repair or replace as necessary" will not reduce the period of warranty coverage. Any such part repaired or replaced under warranty must be warranted for a time not less than the remaining warranty period.
  - (3.) Any warranted part that is scheduled for replacement as required maintenance in the written instructions must be warranted for the period of time prior to the first scheduled replacement point for that part. If the part fails prior to the first scheduled replacement, the part must be repaired or replaced by the Ariens Company. Any such part repaired or replaced under warranty must be warranted for a time not less than the remainder of the period prior to the first scheduled replacement point for the part.

- (4.) Repair or replacement of any warranted part under the warranty provisions of this article must be performed at no charge to the owner at an authorized Ariens, Gravelly, or Parker service representative.
- (5.) Notwithstanding the provisions of subsection (4) above, warranty services or repairs must be provided at authorized Ariens, Gravelly, or Parker service representatives that are franchised to service the subject small off-road equipment.
- (6.) The owner must not be charged for diagnostic labor that leads to the determination that a warranted part is in fact defective, provided that such diagnostic work is performed at an authorized Ariens, Gravelly, or Parker service representative.
- (7.) Throughout the evaporative emission control system's warranty period set out in subsection (b)(2), the Ariens Company must maintain a supply of warranted parts sufficient to meet the expected demand for such parts.
- (8.) Manufacturer-approved replacement parts must be used in the performance of any warranty maintenance or repairs and must be provided without charge to the owner. Such use will not reduce the warranty obligations of the manufacturer issuing the warranty.
- (9.) The use of any add-on or modified parts will be grounds for disallowing a warranty claim made in accordance with this article. The manufacturer issuing the warranty will not be liable under this Article to warrant failures of warranted parts caused by the use of an add-on or modified part.

### **Evaporative Emission Warranty Parts List**

The following parts are considered emission-related components for evaporative emissions:

- Fuel Tank, Fuel Cap and Tether
- Fuel Line, Fuel Line Fittings, Clamps\*
- Pressure Relief Valves, Control Valves\*
- Control Solenoids\*, Electronic Controls\*
- Vacuum Control Diaphragms\*
- Control Cables\*, Control Linkages\*
- Purge Valves
- Vapor Hoses, Liquid/Vapor Separator
- Carbon Canister, Canister Mounting Brackets
- Carburetor Purge Port Connector

\* As related to the evaporative emission control system

### **Disclaimer**

New equipment sold in the state of California that uses small off-road engines must be exclusively certified and appropriately labeled for sale in California. Some equipment covered by this Owner's Manual may not be certified for sale in California and the presence of the preceding CARB and EPA Warranty Statement does not by its existence indicate which, if any, of the equipment covered by this Owner's Manual may be sold in California.

Some equipment covered by this Owner's Manual may have been manufactured prior to certain affectivity dates requiring the inclusion of evaporative emission control systems. Therefore some equipment covered by this Owner's Manual may not include the evaporative emission control systems referred to in the preceding CARB and EPA Warranty Statement.





GRAVELY  
655 West Ryan Street  
Brillion, WI 54110  
920-756-4688  
Fax 920-756-2407  
[www.gravelly.com](http://www.gravelly.com)



## **WARNING**



The engine exhaust from this product contains chemicals known to the State of California to cause cancer, birth defects or other reproductive harm.

An *Ariens* Company Brand