



Hydraulic Service Jack

Operating Instructions & Parts Manual

Model Number
Atd-7333

Capacity
2-1/2 Ton

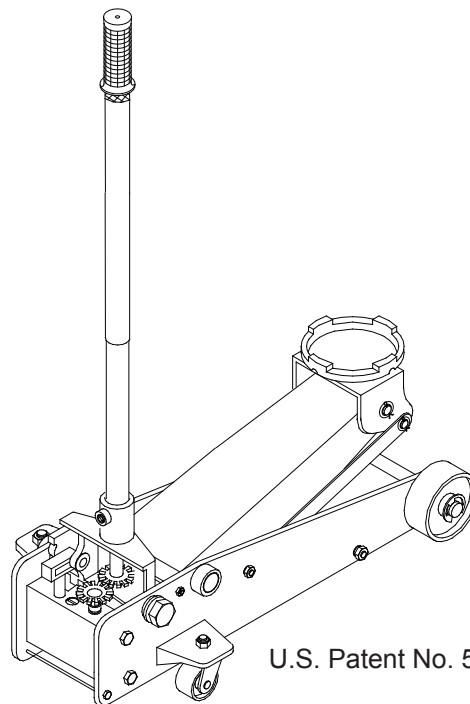

U.S. Patent No. 5,946,912



This is the safety alert symbol. It is used to alert you to potential personal injury hazards. Obey all safety messages that follow this symbol to avoid possible injury or death.

ADVERTENCIA

- Leer, comprender, y seguir las instrucciones antes de utilizar el aparato.
- El manual de instrucciones y la información de seguridad deben estar comunicado en lengua del operador antes del uso.
- No seguir estas indicaciones puede causar daños personales o materiales.

WARNING

To avoid **crushing and related injuries**:



NEVER work on, under or around a load supported only by a hydraulic jack. **ALWAYS** use adequately rated jack stands.

Atd Tools Inc.
160 Enterprise Drive, Wentzville, MO 63385

OIPM#7333-0310
Printed in China

SAFETY and GENERAL INFORMATION

Save these instructions. For your safety, read, understand, and follow the information provided with and on this jack before using. The owner and operator of this equipment shall have an understanding of this jack and safe operating procedures before attempting to use. The owner and operator shall be aware that use and repair of this product may require special skills and knowledge. Instructions and safety information shall be conveyed in the operator's native language before use of this jack is authorized. If any doubt exists as to the safe and proper use of this jack, remove from service immediately.

Inspect before each use. Do not use if broken, bent, cracked or damaged parts are noted. Any jack that appears damaged in any way, or operates abnormally shall be removed from service immediately. If the jack has been or suspected to have been subjected to a shock load (a load dropped suddenly, unexpectedly upon it), immediately discontinue use until jack has been checked by a factory authorized service center (contact distributor or manufacturer for list of authorized service centers). It is recommended that an annual inspection be done by qualified personnel. Labels and Operator's Manuals are available from manufacturer.

PRODUCT DESCRIPTION

Hydraulic Service Jack is designed to lift, but not support, one end of a vehicle. Immediately after lifting, loads must be supported by a pair of appropriately rated jack stands.



NEVER use hydraulic jack as stand-alone device. After lifting, **immediately** support the lifted vehicle with a pair of appropriately rated jack stands.

PREPARATION

Assembly

1. Assemble the 2-piece handle with provided bolt.
2. Insert handle into the handle fork. Tighten the bolt on handle fork to prevent accidental removal of handle while in use.

Before Use

1. Verify that the product and application are compatible, if in doubt call ATD Tools Technical Service line (636)327-9050.
2. Before using this product, read the operator's manual completely and familiarize yourself thoroughly with the product, its components and recognize the hazards associated with its use.
3. To familiarize yourself with basic operation, locate and turn the release valve (handle):
 - a. Clockwise until firm resistance is felt to further turning. This is the '**CLOSED**' release valve position used to **raise** the saddle.
 - b. Counter-clockwise, but no more than 1/2 turn from the closed position. This is the '**OPEN**' release valve position used to **lower** the saddle.
4. With saddle fully lowered, remove the oil filler plug. Pump 6 to 8 full strokes. This will help release any pressurized air which may be trapped within the reservoir. Check oil level. Proper oil level will vary from just covering the ram cylinder to 3/16" above it as seen from the oil filler hole. Reinstall the oil filler plug.
5. Ensure that jack rolls freely. Raise and lower the unloaded saddle throughout the lifting range before putting into service to ensure the pump operates smoothly. Replace worn or damaged parts and assemblies with ATD Tools authorized replacement parts only.

Bleeding / Venting Trapped Air

With the release valve in the OPEN position (3b.) and with saddle fully lowered, locate and remove the oil filler plug. Pump 6 to 8 full strokes. This will help release any pressurized air which may be trapped within the reservoir. Reinstall the oil filler plug.

SPECIFICATIONS

Model	Capacity	Jack Size (L x W x H)	Min. Height	Max. Height	Saddle Dia.
Atd-7333	2-1/2 Ton	25-3/8" x 13-1/8" x 6-1/2"	5"	19-1/2"	5"

OPERATION

Lifting



Only attachments and/or adapters supplied by the manufacturer shall be used. Lift only on area of the vehicle as specified by the vehicle manufacturer.

1. Follow the vehicle manufacturer's recommended guidelines for lifting. Engage the emergency brake and chock each unlifted wheel in both directions to prevent inadvertent vehicle movement.
2. Close the release valve by turning the handle clockwise until firm resistance is felt.
3. Refer to the vehicle manufacturer owner's manual to locate approved lifting points on the vehicle. Center jack saddle under lift point.
4. Verify lift point, then pump handle to contact lift point. To lift, pump handle until load reaches desired height.
5. Transfer the load **immediately** to appropriately rated jack stands.



NEVER use hydraulic jack as a stand alone device! **ALWAYS** transfer the lifted load **IMMEDIATELY** to a pair of appropriately rated jack stands. Use one pair of jack stands per vehicle. Rated capacity is per pair only! Do not exceed rated capacity.

Lowering



*Be sure all tools and personnel are clear before lowering load. **Slowly open the release valve!** The more you turn the handle counter-clockwise, the faster the load will come down. **Maintain control** of the rate of speed at which the load lowers at all times!*

1. Raise load high enough to clear the jack stands.
2. Remove jack stands carefully (**always** used in pairs).
3. **Slowly** turn the handle counter-clockwise, but no more than 1/2 full turn. If the load fails to lower:
 - a. Use another jack to raise the vehicle high enough to reinstall jack stands.
 - b. Remove the malfunctioning jack and then the jack stands.
 - c. Use the functioning jack to lower the vehicle.
4. After removing jack from under the vehicle, fully lower the saddle to reduce ram exposure to rust and contamination.

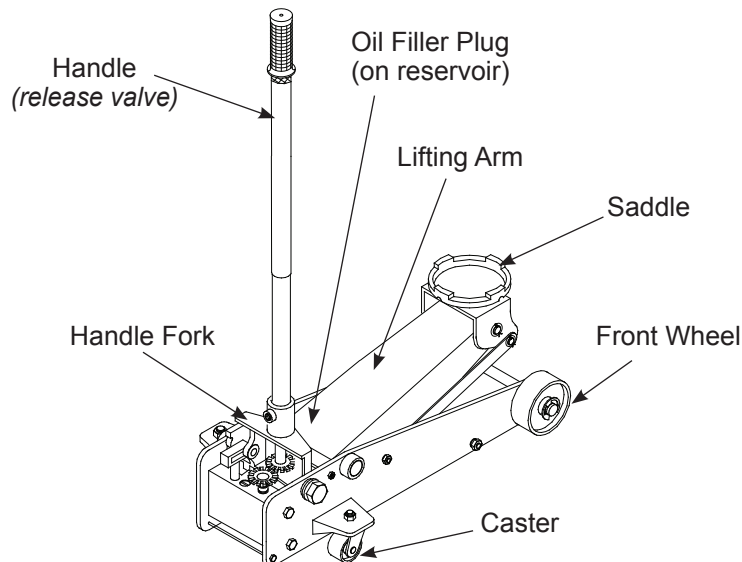



Figure 1 - Typical Service Jack Nomenclature

⚠ WARNING

- **Study, understand, and follow** all printed materials provided with/on this product **before use**.
- **Do not** exceed rated capacity.
- Use **only** on hard, level surface.
- **This is a lifting device only!**
- **Immediately** after lifting, support the load with a **pair** of appropriately rated jack stands.
- Lift **only** on areas of the vehicle as specified by the vehicle manufacturer.
- **Do not** move or **dolly** the **vehicle** while on the jack.
- No alterations shall be made to this product.

FAILURE TO HEED THESE MARKINGS MAY RESULT IN PERSONAL INJURY AND/OR PROPERTY DAMAGE

⚠ WARNING



To avoid **crushing and related injuries**:

- **Never** work on, under or around a load supported only by hydraulic jack.
- **Always** use adequately rated jack stands.
- Chock each unlifted tire in both directions.
- **Do not** use this device to lift, level, lower, support nor move a house, mobile home, travel trailer, camper or any building structure.
- **Be alert** and **sober** when using this product. Do not operate under the influence of drugs or alcohol.

MAINTENANCE

Important: Use only good grade hydraulic jack oil. Avoid mixing different types of fluid and NEVER use brake fluid, turbine oil, transmission fluid, motor oil or glycerin. Improper fluid can cause premature failure of the jack and the potential for sudden and immediate loss of load. We recommend Mobil DTE 13M or equivalent.

Adding oil

1. With saddle fully lowered set jack in its upright, level position. Remove oil filler plug.
2. Fill with oil until ~3/16" above the inner cylinder as seen from the oil filler hole. Reinstall the oil filler plug.

Changing oil

For best performance and longest life, replace the complete fluid supply at least once per year.

1. With saddle fully lowered, remove the oil filler plug.
2. Lay the jack on its side and drain the fluid into a suitable container.

Note. Dispose of hydraulic fluid in accordance with local regulations.

3. Fill with oil until ~3/16" above the inner cylinder as seen from the oil filler hole. Reinstall oil filler plug.

Lubrication

A periodic coating of light lubricating oil to pivot points, axles and hinges will help to prevent rust and assure that wheels, casters and pump assemblies move freely.

Cleaning

Periodically check the pump piston and ram for signs of rust or corrosion. Clean as needed and wipe with an oily cloth.

Note: Never use sandpaper or abrasive material on these surfaces!

Storage

When not in use, store the jack with saddle fully lowered.

TROUBLESHOOTING

Symptom	Possible Causes	Corrective Action
Jack will not lift load	<ul style="list-style-type: none"> • Release valve not tightly closed • Load is too heavy 	<ul style="list-style-type: none"> • Ensure release valve tightly closed • Consider higher capacity jack
Jack will lift, but not maintain pressure	<ul style="list-style-type: none"> • Release valve not tightly closed • Hydraulic unit malfunction 	<ul style="list-style-type: none"> • Ensure release valve tightly closed • Discontinue use, contact ATD Tools technical service
Jack will not lower after unloading	<ul style="list-style-type: none"> • Reservoir overfilled • Linkages binding • Fluid level low 	<ul style="list-style-type: none"> • Drain fluid to proper level • Clean and lubricate moving parts • Ensure proper fluid level
Poor lift performance	<ul style="list-style-type: none"> • Fluid level low • Air trapped in system 	<ul style="list-style-type: none"> • Ensure proper fluid level • With ram fully retracted, remove oil filler plug/screw to let pressurized air escape. Reinstall oil filler plug
Will not lift to full extension	<ul style="list-style-type: none"> • Fluid level low 	<ul style="list-style-type: none"> • Ensure proper fluid level

REPLACEMENT PARTS

Available Parts: Please refer to the Parts drawing when ordering parts. Not all components of this kit are replacement items, but are illustrated as a convenient reference of location and position in the assembly sequence. When ordering parts, give Model number, serial number and description below. Call or write for current pricing:
 Atd Tools Inc. 160 Enterprise Drive, Wentzville, MO 63385 Tel:(636)327-9050 Fax:(636)327-9046

ONE YEAR LIMITED WARRANTY

For a period of one (1) year from date of purchase, **Atd Tools Inc.** will repair or replace, at its option, without charge, any of its products which fails due to a defect in material or workmanship, or which fails to conform to any implied warranty not excluded hereby.

Performance of any obligation under this warranty may be obtained by returning the warranted product, freight prepaid, to **Atd Tools Inc.** Warranty Service Department, 160 Enterprise Drive, Wentzville, MO 63385.

Except where such limitations and exclusions are specifically prohibited by applicable law, (1) the CONSUMER'S SOLE AND EXCLUSIVE REMEDY SHALL BE THE REPAIR OR REPLACEMENT OF DEFECTIVE PRODUCTS AS DESCRIBED ABOVE, and (2) **Atd Tools Inc.** SHALL NOT BE LIABLE FOR ANY CONSEQUENTIAL OR INCIDENTAL DAMAGE OR LOSS WHATSOEVER, and (3) THE DURATION OF ANY AND ALL EXPRESSED AND IMPLIED WARRANTIES, INCLUDING WITHOUT LIMITATION, ANY WARRANTIES OF MERCHANTABILITY AND FITNESS FOR A PARTICULAR PURPOSE, IS LIMITED TO A PERIOD OF ONE (1) YEAR FROM DATE OF PURCHASE.

Some states do not allow limitations on how long an implied warranty lasts, so the above limitation may not apply to you. Some states do not allow the exclusion or limitation of incidental or consequential damages, so the above limitation or exclusion may not apply to you. This warranty gives you specific legal rights, and you may also have other rights which vary from state to state.

Replacement Parts Illustration for model Atd-7333

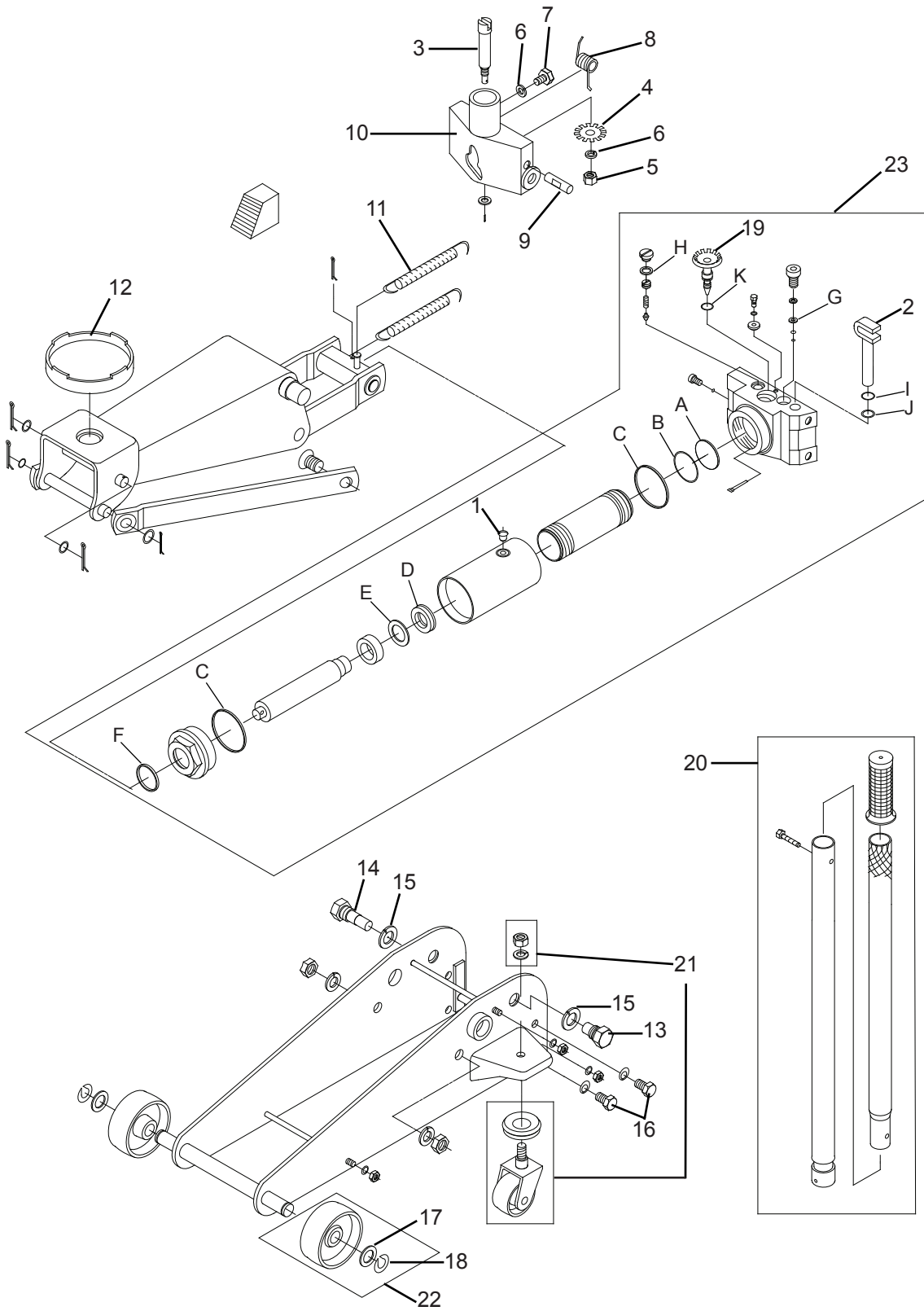

Figure 2 - Replacement Parts Illustration for Model Atd-7333

Replacement Parts List for model Atd-7333

Item	Part No for Atd-7333	Description	Qty
1	F36100-0001	Oil Filler Plug	1
2	G48900-0023	Pump Piston	1
3	G48900-0017	Release Valve Connecting Bar	1
4	G48900-0016	Release Valve Gear	1
5	G59305-0003	Nut M10	1
6	G59305-0005	Lock Washer ϕ 10	2
7	G48900-0024	Bolt M10x16	1
8	G48900-0001	Return Spring, Handle Fork	1
9	G48900-0015	Pin	1
10	G58900-0002	Handle Fork	1
11	G48900-0011	Return Spring	2
12	G59508-0004	Saddle	1
13	G48900-0018	Handle Bolt, Left	1
14	G48900-0020	Handle Bolt, Right	1
15	G59305-0006	Lock Washer ϕ 20	2
16	G48900-0019	Bolt M12	4
17	G59305-0004	Washer ϕ 18	2
18	G59305-0007	E-ring	2
19	G48900-0004	Release Valve	1
20	G48900-0003	Handle Assembly	1
21	G48900-0006	Caster Assembly	2
22	G48900-0007	Front Wheel Assembly	2
23	G49000-0001	Hydraulic Power Unit	1
24	G48903-0000	Seal Kit (includes #1, A~K)	-

Seal Kit Contents:

Item	Description	Qty.
1	Oil Filler Plug	1
A	O-ring	1
B	Back-up Washer	1
C	O-ring	2
D	U-cup	1
E	Back-up Washer	1
F	O-ring	1
G	O-ring	1
H	O-ring	1
I	Back-up Washer	1
J	O-ring	1
K	O-ring	1

Notes



Atd Tools Inc.
160 Enterprise Drive, Wentzville, MO 63385
Tel: (636)327-9050 Fax: (636)327-9046 www.atdtools.com