

INSTALLATION MANUAL **COLOR DGPS/PLOTTER GP-1850WD** **COLOR GPS PLOTTER GP-1850W**

SAFETY INSTRUCTIONS

SYSTEM CONFIGURATION i

EQUIPMENT LISTS ii

1. INSTALLATION **1**

1.1 Installation of Display Unit 1

1.2 Installation of Antenna Unit 4

2. WIRING **5**

3. INITIAL SETTINGS **9**

3.1 NMEA Setting 9

3.2 Output Data Sentences 11

3.3 Antenna Height 12

3.4 DGPS Setting 13

4. INCORPORATION OF DGPS BEACON RECEIVER KIT
(for GP-1850W) **15**

PACKING LISTS A-1

OUTLINE DRAWINGS D-1

INTERCONNECTION DIAGRAM S-1



FURUNO ELECTRIC CO., LTD.
NISHINOMIYA, JAPAN



SAFETY INSTRUCTIONS

Safety Instructions for the Installer



WARNING

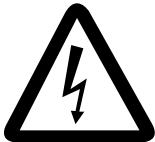

Do not work inside the equipment unless totally familiar with electrical circuits.

Hazardous voltage which can shock, burn or cause serious injury exists inside the equipment.



Turn off the power at the mains switchboard before beginning the installation. Post a sign near the switch to indicate it should not be turned on while the equipment is being installed.

Fire, electrical shock or serious injury can result if the power is left on or is applied while the equipment is being



CAUTION



Ground the equipment to prevent electrical shock and mutual interference.

Confirm that the power supply voltage is compatible with the voltage rating of the equipment.

Connection to the wrong power supply can cause fire or equipment damage. The voltage rating appears on the label at the rear of the display unit.

Use the correct fuse.

Use of a wrong fuse can cause fire or equipment damage.

Keep the following compass safe distance.

	Standard	Steering
Display unit	0.5 m	0.3 m

This page is intentionally left blank.

SYSTEM CONFIGURATION

The GP-1850W/1850WD mainly consists of a display unit and a GPS antenna. A DGPS beacon receiver is provided inside the display unit for GP-1850WD type. The mini chart card drive in the display unit loads electronic charts. External equipment which may be connected include an autopilot and a DGPS beacon receiver (GP-1850W).

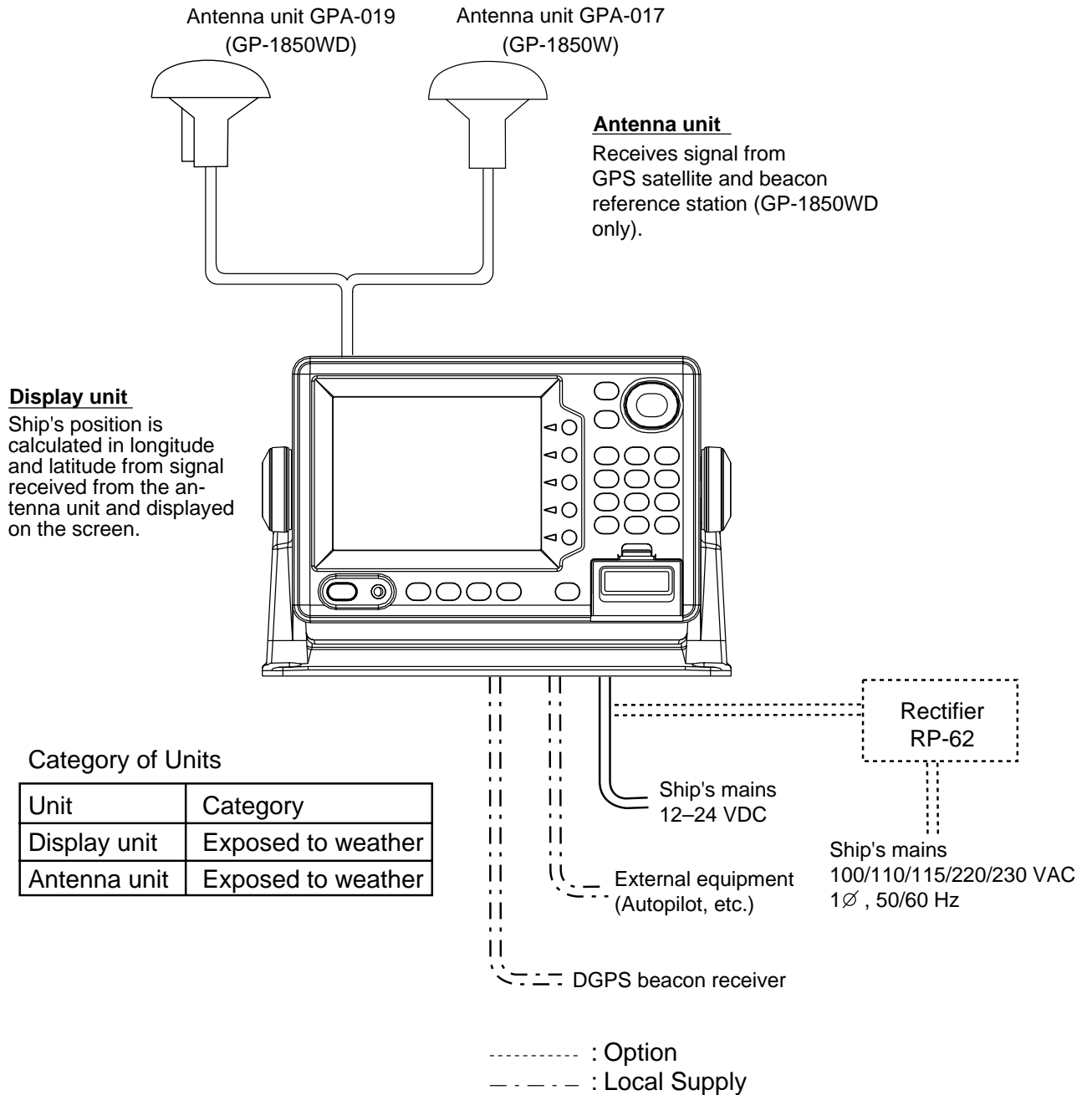

EQUIPMENT LISTS

Standard supply

Name	Type	Code No.	Qty	Remarks
Display Unit	GP-1850W-E	-	1	
	GP-1850WD-E	-		
Antenna Unit	GPA-017	-	1	for GP-1850W
	GPA-019	-		for GP-1850WD
Spare Parts*	SP14-02501	004-375-260	1	Fuse
Installation Materials*	CP14-05200	000-041-496	1	Power cable, cable assy.
Accessories*	FP14-02410	000-041-535	1	FP14-02401, FP14-02403

*: Refer to Packing list at the end of this manual.

Optional equipment

Name	Type	Code No.	Remarks
DGPS Beacon receiver kit	GR-7000A-1650-10N-019	000-041-650	GPA-019, GR-7000A
	GR-7000A-1650-15N-019S	000-041-653	GPA-019S, GR-7000A
Antenna cable assy.	TNC-PS-3D-15	000-133-670	15 m, for antenna cable extension
Antenna cable set	CP20-01700	004-372-110	8D-FB-CV *30M* and CP20-01701, for antenna cable extension
	CP20-01710	004-372-120	8D-FB-CV *50M* and CP20-01701, for antenna cable extension
Cable Assy.	MJ-A7SPF0003-050	000-136-730-01	
Mast mount fixture	CP20-0111	004-365-780	
Right-angle antenna base	No.13-QA330	000-803-239	for antenna unit mounting
L-angle antenna base	No.13-QA310	000-803-240	
Antenna base for rail mounting	No.13-RC5160	000-806-114	
Antenna Unit	GPA-019S	-	GP-1850WD
	GPA-017S	-	GP-1850W

Optional equipment (con't)

Name	Type	Code No.	Remarks
Rectifier	PR-62	000-013-484	for 100 VAC
		000-013-485	for 110 VAC
		000-013-486	for 220 VAC
		000-013-487	for 230 VAC
Cable Assy.	MJ-A6SPF0011-050	000-132-244	for radar, 6P-4P, 5 m
	MJ-A6SPF0011-100	000-132-336	for radar, 6P-4P, 10 m
	MJ-A6SPF0012-050	000-134-424	for navaid or E/S, 6P-6P, 5 m
	MJ-A6SPF0012-100	000-133-817	for navaid or E/S, 6P-6P, 10 m
Remote controller	RMC-185-E	004-375-300	Conttoller, vinyl cover, battery
RAM Card	00RAM02MC-004	004-371-790	2MB
C-MAP modification kit	1650/1850-MAP	004-376-420	

EQUIPMENT LISTS

This page is intentionally left blank.

1. INSTALLATION

1.1 Installation of Display Unit

Mounting considerations

The display unit can be installed on a tabletop, on the overhead or flush mounted in a console or panel.

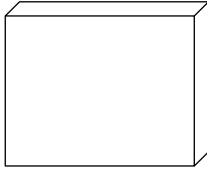

Hard Cover

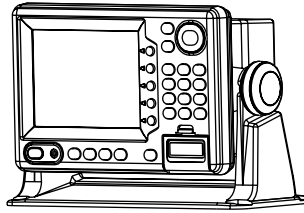

Tabletop

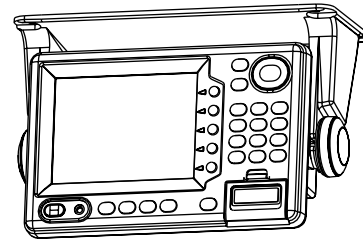

Overhead

Tabletop, overhead mounting methods

When selecting a mounting location for the display unit keep the following in mind:

- Keep the display unit out of direct sunlight.
- The temperature and humidity should be moderate and stable.
- Locate the unit away from exhaust pipes and vents.
- The mounting location should be well ventilated.
- Mount the unit where shock and vibration are minimal.
- Keep the unit away electromagnetic field generating equipment such as motor, generator.
- For maintenance and checking purposes, leave sufficient space at the sides and rear of the unit and leave slack in cables.
- A magnetic compass will be affected if placed too close to the display unit. Observe the following compass safe distances to prevent disturbance to the magnetic compass:

Standard compass: 0.5 meters

Steering compass: 0.3 meters

1. INSTALLATION

- Rubber foot which absorb vibration (supplied) maybe attached as below if vibration is a problem.

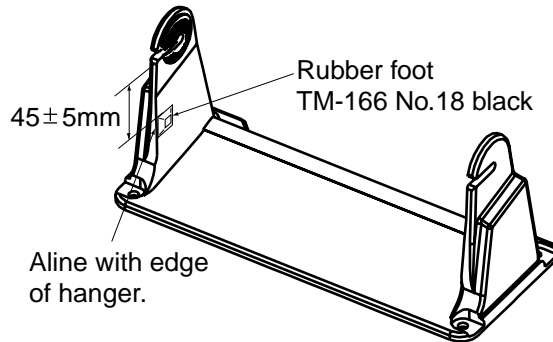

Mounting procedure

Follow the procedure below to mount the display unit on a tabletop or the overhead.

Tabletop, overhead mounting

1. Fix the hanger by four tapping screws 5 X 16.
2. Screw knob bolts in display unit, set it to hanger, and tighten knob bolts.
3. Attach hard cover to protect LCD.

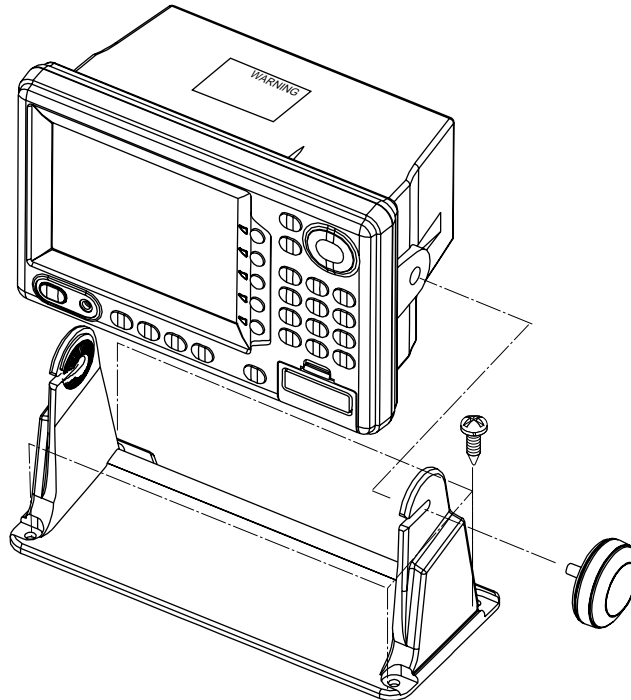

Tabletop, overhead mounting of display unit

Flush mounting

Note: Use supplied pan head screws when the thickness of the bulkhead is from 11 to 14 mm. For bulkhead which exceeds 14 mm in thickness the length of the pan head screws should be bulkhead thickness plus 7.3 ± 1.5 mm. Also the length of B should max. 7mm.

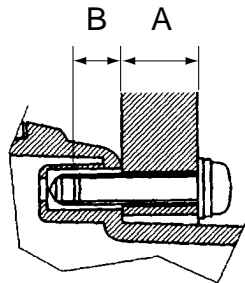

1. Prepare a cutout in the mounting location whose dimensions are as shown on the next page.
2. Fix the display unit by six pan head screws M4 X 20. Refer to the outline drawing on page D-2.

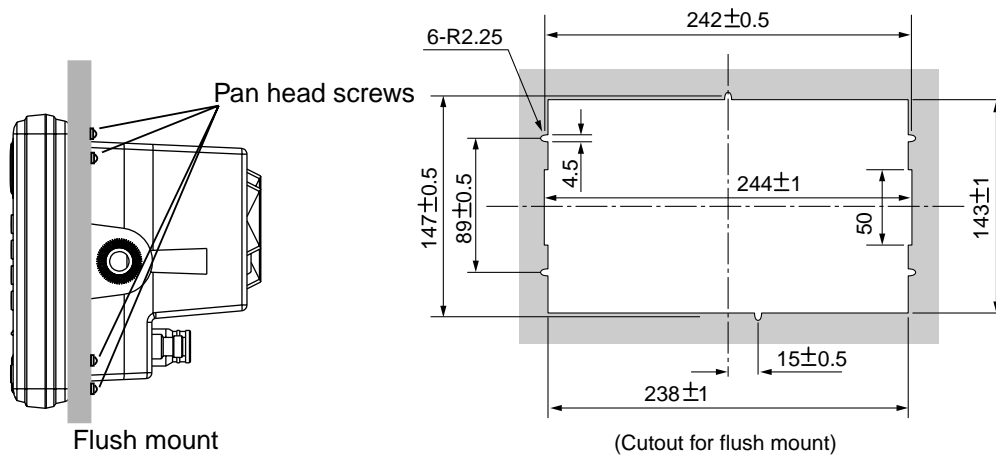

Flush mounting of display unit

1.2 Installation of Antenna Unit

Mounting considerations

Install the antenna unit referring to the installation diagram on page D-3 or D-4. When selecting a mounting location for the antenna unit, keep in mind the following points:

- Select a location out of the radar beam. The radar beam will obstruct or prevent reception of the GPS satellite signal.
- The location should be well away from a VHF antenna. A GPS receiver is interfered by a harmonic wave of a VHF antenna.
- There should be no interfering object within the line-of-sight to the satellites. Objects within line-of-sight to a satellite, for example, a mast, may block reception or prolong acquisition time.
- Mount the antenna unit as high as possible. Mounting the antenna unit as high as possible keeps it free of interfering objects and water spray, which can interrupt reception of GPS satellite signal if the water freezes.
- If the antenna cable is to be passed through a hole which is not large enough to pass the connector, you may unfasten the connector with a needle nose pliers and 3/8-inch open-end wrench. Refasten it as shown in the figure below after running the cable through the hole.

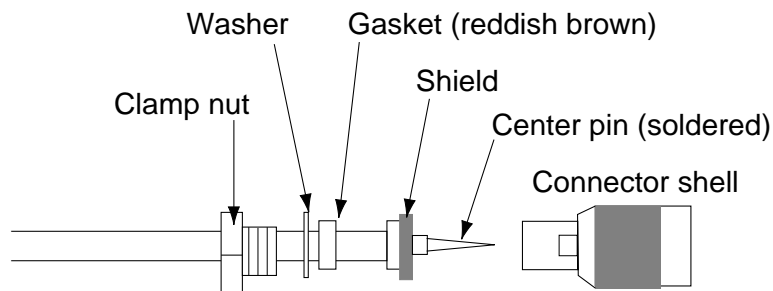

How to assemble the connector

2. WIRING

All wiring are terminated at the rear of the display unit.

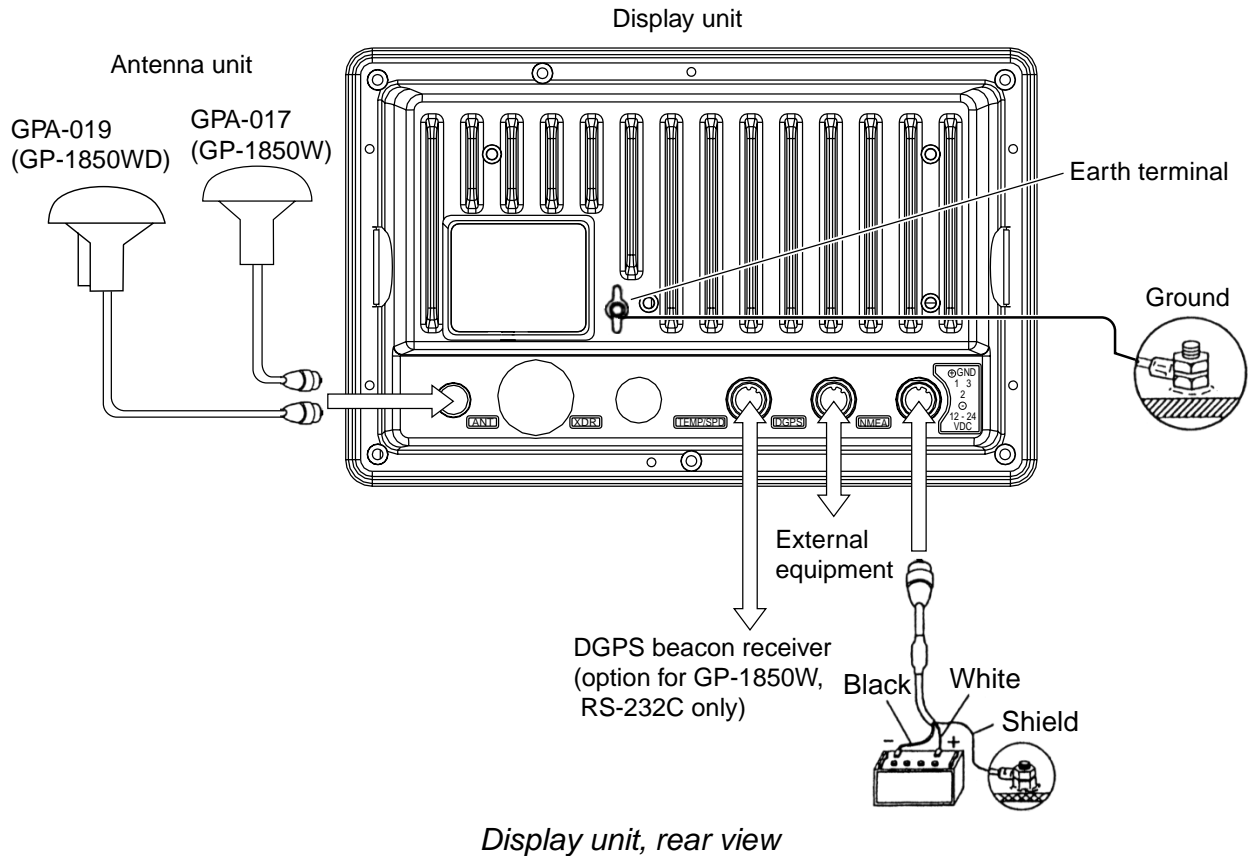

Power cable

Connect the power cable to the power connector. Connect the leads to the battery (12 or 24 VDC); white to plus(+) terminal and black to minus(-) terminal.

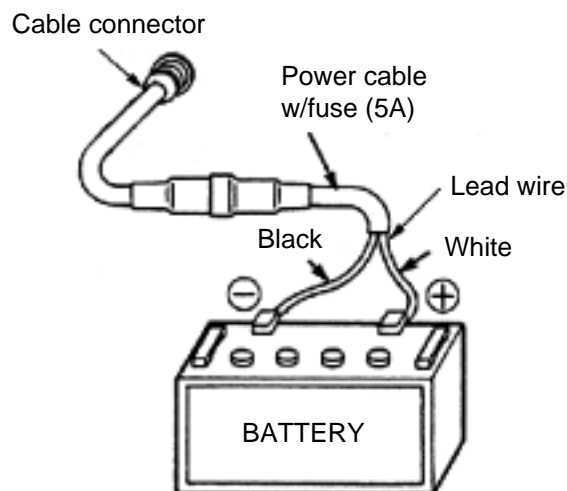

Connecting the power cable to the battery

Antenna unit

Connect the antenna cable to the ANT connector.

Ground

The display unit contains several CPUs. While they are operating, they radiate noise, which can interfere with radio equipment. Ground the unit to prevent interference. The grounding wire should be 1.25 sq or larger and as short as possible. Connect the grounding wire to ship's ground. On a fiberglass boat, it is best to install a ground plate that measures about 20 cm by 30 cm on the outside of the hull bottom to provide a ground point. If this is not practical, the engine block can be used.

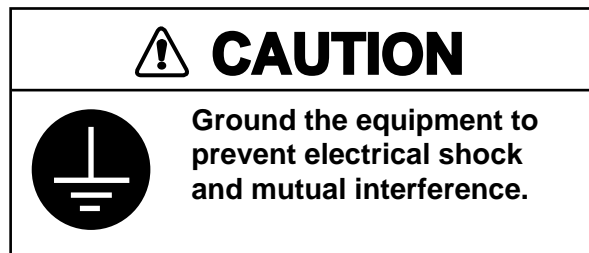

Note: Use a “closed” lug to make the ground connection at the display unit. Do not use an “open-type” lug ()

Extending antenna cable length

The standard cable is 10 m long. For extension, in case of the GPA-019S or GPA-017S, an antenna cable set of 15m, 30 m or 50 m is available. Extension cable cannot be used with the GPA-017 or GPA-019.

Cable length	Necessary parts	Code No.
15 m	TNC-PS-3D-15	000-133-670
30 m	CP20-01700	004-372-110
50 m	CP20-01710	004-372-120

Extension cable line-up (in case of 15 m, 30 m or 50 m)

Fabricate the end of the antenna cable and attach the coaxial connector. Details are shown on the page 8.

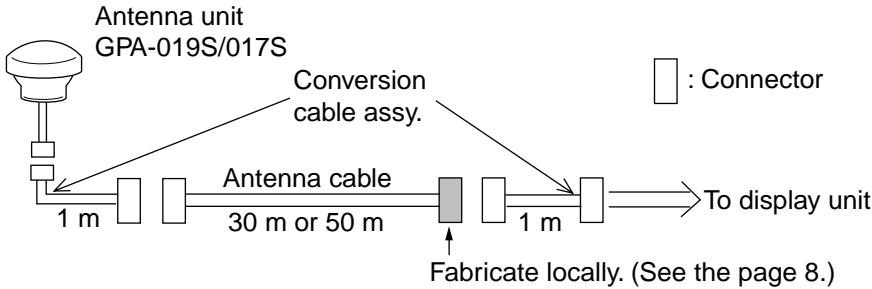

Cable extension (CP20-01700, CP20-01710)

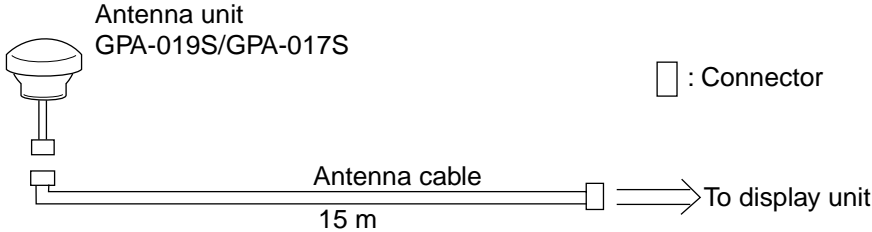

Cable extension (TNC-PS-3D-15)

Waterproofing connector

Wrap connector with vulcanizing tape and then vinyl tape. Bind the tape end with cable-tie.

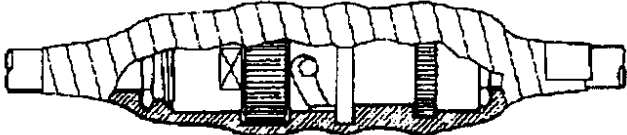

Waterproofing connector

How to attach the N-P-8DFB connector

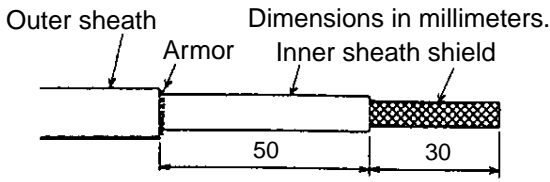

Remove outer sheath and armor by the dimensions shown left.
Expose inner sheath and shield by the dimensions shown left.

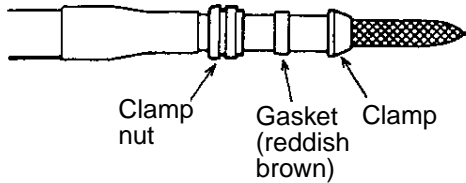
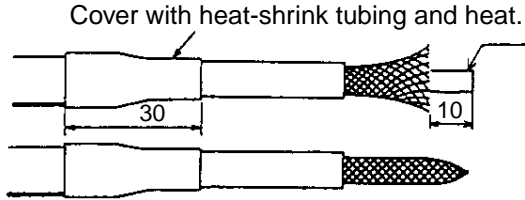

Slip on clamp nut, gasket and clamp as shown left.

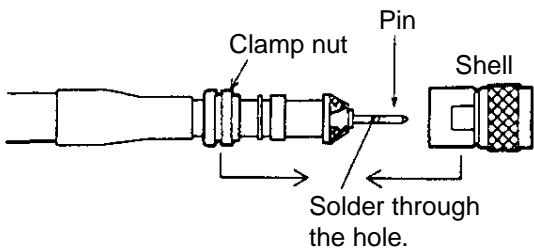
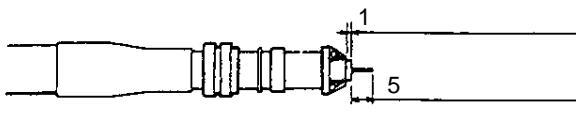
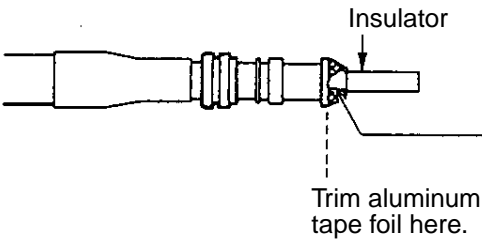
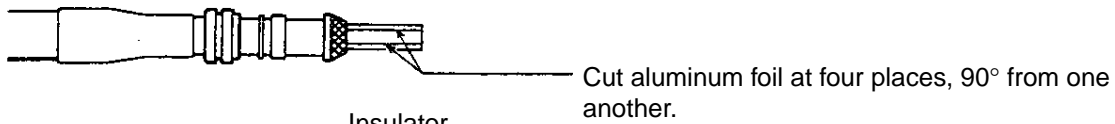
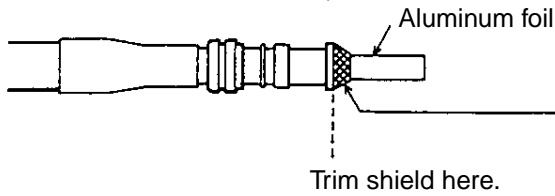

Slip the pin onto the conductor. Solder them together through the hole on the pin.

Insert the pin into the shell. Screw the clamp nut into the shell.
(Tighten by turning the clamp nut. Do not tighten by turning the shell.)

Fabrication of coaxial cable

3. INITIAL SETTINGS

3.1 NMEA Setting

NMEA port

This setting should be done when connecting with other equipment, autopilot, radar or remote display.

1. Press the [MENU] key.
2. Press the CONFIGURATION soft key.
3. Press the SETUP NMEA PORT1 soft key.
4. Press the cursor pad to select FORMAT.
5. Press the EDIT soft key to display the following window.

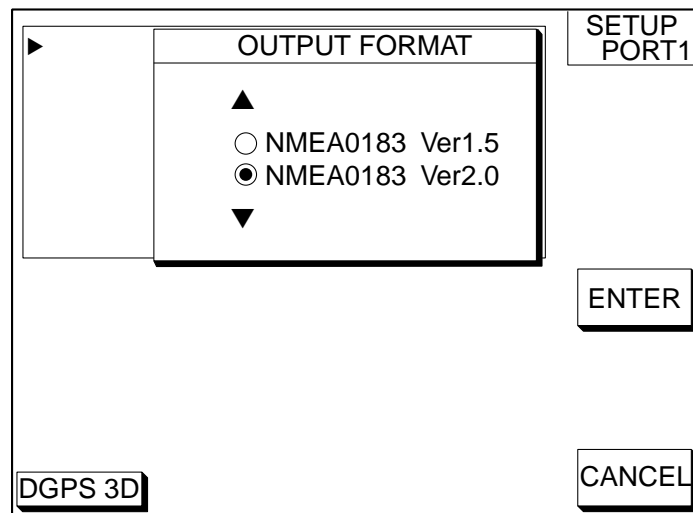

Output format window (PORT 1)

6. Select NMEA version depending on the specification of the equipment connected. The selected item is indicated by black button.
7. Press the ENTER soft key.
8. Press the [PLOT] key to return to the plotter display.

3. INITIAL SETTINGS

DGPS port

Set the following when connecting with DGPS beacon receiver GR-80 or the DGPS beacon receiver is incorporated, PC to the DGPS port.

Note: Signal level for DGPS port is RS232C.

1. Press the [MENU] key.
2. Press the CONFIGURATION soft key.
3. Press the SETUP NMEA/DGPS PORT 2 soft key.
4. Select FORMAT, and then press the EDIT soft key.

The following window appears.

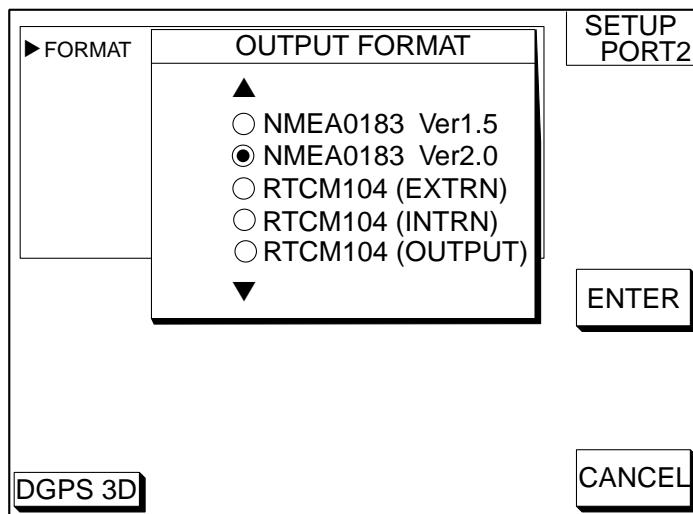

Output format window (PORT 2)

5. Select NMEA version. The selected item is indicated by black button.
NMEA0183 Ver1.5/2.0: Select one when connecting PC or RS-232C equipment.
RTCM104 (EXTERN): Select this when connecting external DGPS beacon receiver.
RTCM104 (INTRN): Select this for built in internal DGPS beacon receiver.
RTCM104 (OUTPUT): Select this when outputting differential data of the internal DGPS beacon receiver to other GPS navigator.

Note 1: Note that you cannot setup sentences when you select RTCM104 at the format.

Note 2: For RS-422 format, the level converter (IF-1432) is required for connection of external equipment.

6. Press the ENTER soft key.
7. Press the [PLOT] key to finish.

3.2 Output Data Sentences

Select output data sentences for external equipment as follows.

1. Press the [MENU] key.
2. Press the CONFIGURATION soft key.
3. Press the SETUP NMEA PORT1 soft key.
4. Press the SELECT SNTNC. soft key to display the SELECT SENTENCE window.

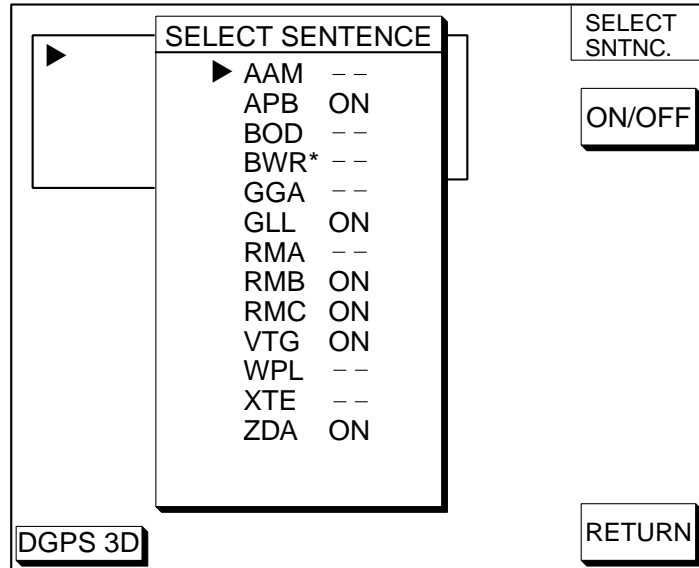

*: BWR for Rhumb line
BWC for Great circle

Select sentence window

5. Select data sentence you want to output.
6. Press the ON/OFF soft key. To output data, select ON.
7. Repeat to select other sentences.
8. Press the RETURN soft key.
9. Press the [PLOT] key to return the plotter display.

3. INITIAL SETTINGS

Input/Output data sentences

Port		Format	Data	Remarks
NMEA	Input	NMEA-0183 Ver. 2.0 Ver. 1.5 IEC1162	TLL*1, MTW, WPL*1, DBT/DPT	WPL: GP only NMEA Ver 1.5: DBT NMEA Ver 2.0: DPT
	Output		AAM, APB, BOD, BWC/BWR, GGA, GLL, RMA, RMB, RMC, VTG, WPL, XTE, ZDA, MTW, GTD*2	GREAT CIRCLE: BWC RHUMB LINE: BWR
DGPS	Input	NMEA-0183 Ver. 2.0 Ver. 1.5 RS232C RTCM104	TLL*1, MTW, WPL*1, DBT/DPT	WPL: GP only NMEA Ver 1.5: DBT NMEA Ver 2.0: DPT
	Output		AAM, APB, BOD, BWC/BWR, GGA, GLL, RMA, RMB, RMC, VTG, WPL, XTE, ZDA, MTW, GTD*2	GREAT CIRCLE: BWC RHUMB LINE: BWR

*1: Cannot be input consecutively.

*2: Output automatically when LC or LA is selected.

3.3 Antenna Height

Enter height of antenna above water. (Default setting: 5 m)

1. Press the [MENU] key.
2. Press the GPS/DGPS/TD OPTIONS soft key.
3. Press the GPS SETUP OPTIONS soft key.
4. Select ANT. HEIGHT.
5. Press the EDIT soft key.

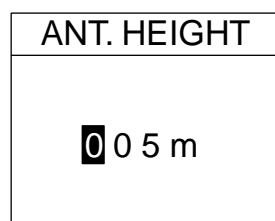

Ant. height window

6. Enter the height (3 digits) of the antenna above sea level using the numeric keys.
If you enter wrong antenna height, press the CLEAR soft key.
7. Press the ENTER soft key.
8. Press the [PLOT] key to return the plotter display.

3.4 DGPS Setting

When external GPS beacon receiver (output: RS-232C only) is connected or the DGPS beacon receiver is incorporated, set the DGPS mode referring to the following procedure.

1. Press the [MENU] key.
2. Press the GPS/DGPS/TD OPTIONS soft key.
3. Press the DGPS/WAAS SETUP OPTIONS soft key.

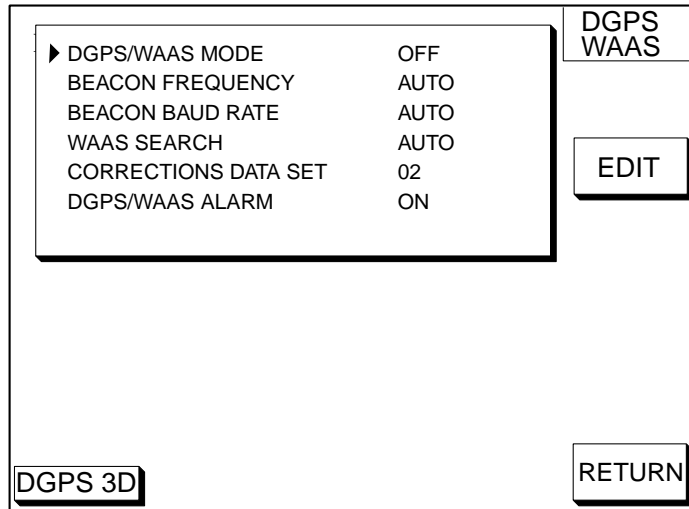

DGPS/WAAS options window

4. Select DGPS/WAAS MODE and press the EDIT soft key.
5. Select DGPS or AUTO and press the ENTER soft key.
 WAAS: WAAS data can be received.
 AUTO: DGPS, WAAS or GPS data can be automatically received, The order of priority is DGPS, WAAS and GPS.

Note: If the external DGPS beacon receiver GR-80 is connected to the GP-1850W, refer to the interconnection diagram below.

Connection with GR-80

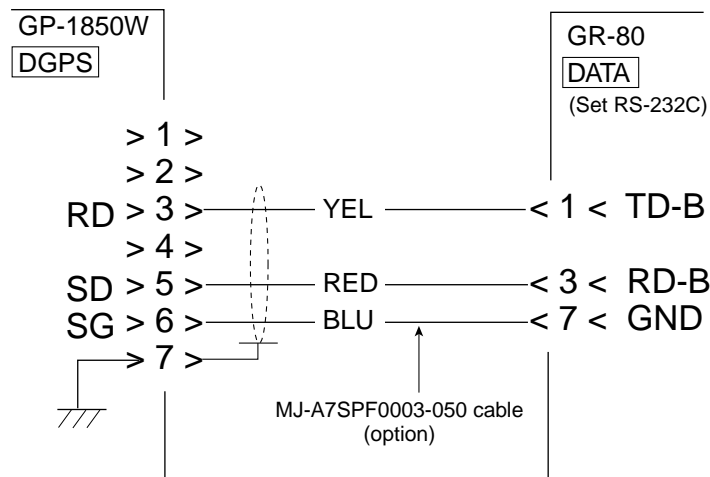

3. INITIAL SETTINGS

6. Select BEACON FREQUENCY by the cursor pad.
7. Press the EDIT soft key to display the following message.

BEACON FREQUENCY	
▲	
<input checked="" type="radio"/>	AUTO
<input type="radio"/>	MANUAL ▶ 284.0 kHz
▼	

Beacon frequency window

8. Select AUTO or MANUAL by the cursor pad. When you select MANUAL, operate the cursor pad to move the cursor to frequency dialog box. And press the cursor pad to select the frequency desired.
AUTO: DGPS reference station can be searched automatically.
9. Press the [ENTER] key.
10. Select BEACON BAUD RATE by the cursor pad.
11. Press the EDIT soft key to display the following window. Beacon baud rate cannot be set when BEACON FREQUENCY is set to AUTO.

BEACON BAUD RATE	
▲	
<input type="radio"/>	200
<input checked="" type="radio"/>	100
<input type="radio"/>	50
▼	

Beacon baud rate window

12. Select beacon baud rate corresponding to DGPS reference station to use.
13. Press the [ENTER] key.
14. Press the [PLOT] key to return the plotter display.

4. INCORPORATION OF DGPS BEACON RECEIVER KIT (for GP-1850W)

The DGPS beacon receiver GR-7000A can be incorporated in the GP-1850W to provide it with DGPS capability. Two kinds of kit are available as shown.

GR-7000A-1650-10N-019

Name	Type	Code No.	Qty
Antenna Unit	GPA-019	000-142-416	1
Beacon Receiver	GR-7000A	000-143-249	1
Connector Assy.	PH6P-W-L240	000-141-548	1
Cable tie	CV-100	000-570-322	2
Pan head screws*	M3X10 C2700W	000-881-405	4
Screw*	M3X12 SUS304	000-805-905	6
Cable Assy.*	S.FL2-2LP0.7-D-WHT (121)	000-141-491	1
Clamp	HP-2N	000-570-000	1
Cable Assy.	S.FL2-2LP0.7-D-WHT (250)	000-143-877	1
Screw	3X8 SUS410	000-881-405	4
Cable Assy.*	S.FL2-2LP0.7-D-WHT (175)	000-141-490	1

* Not used

GR-7000A-1650-15N-019S

Name	Type	Code No.	Qty
Antenna Unit	GPA-019S	000-142-545	1
Beacon Receiver	GR-7000A	000-143-249	1
Cable Assy.	TNC-PS-3D-15	000-133-670	1
Connector Assy.	PH6P-W-L240	000-141-548	1
Cable tie	CV-100	000-570-322	2
Pan head screws*	M3X10 C2700W	000-881-405	4
Screw*	M3X12 SUS304	000-805-905	6
Cable Assy.*	S.FL2-2LP0.7-D-WHT (121)	000-141-491	1
Clamp	HP-2N	000-570-000	1
Cable Assy.	S.FL2-2LP0.7-D-WHT (250)	000-143-877	1
Screw	3X8 SUS410	000-802-951	4
Cable Assy.*	S.FL2-2LP0.7-D-WHT (175)	000-141-490	1

* Not used

Disassembly

Procedure

1. Turn off the power. Wait at least one minute before opening the cover, to allow capacitors to discharge.
2. Remove nuts attached to DGPS, NMEA and power supply connectors at the rear of the display unit.

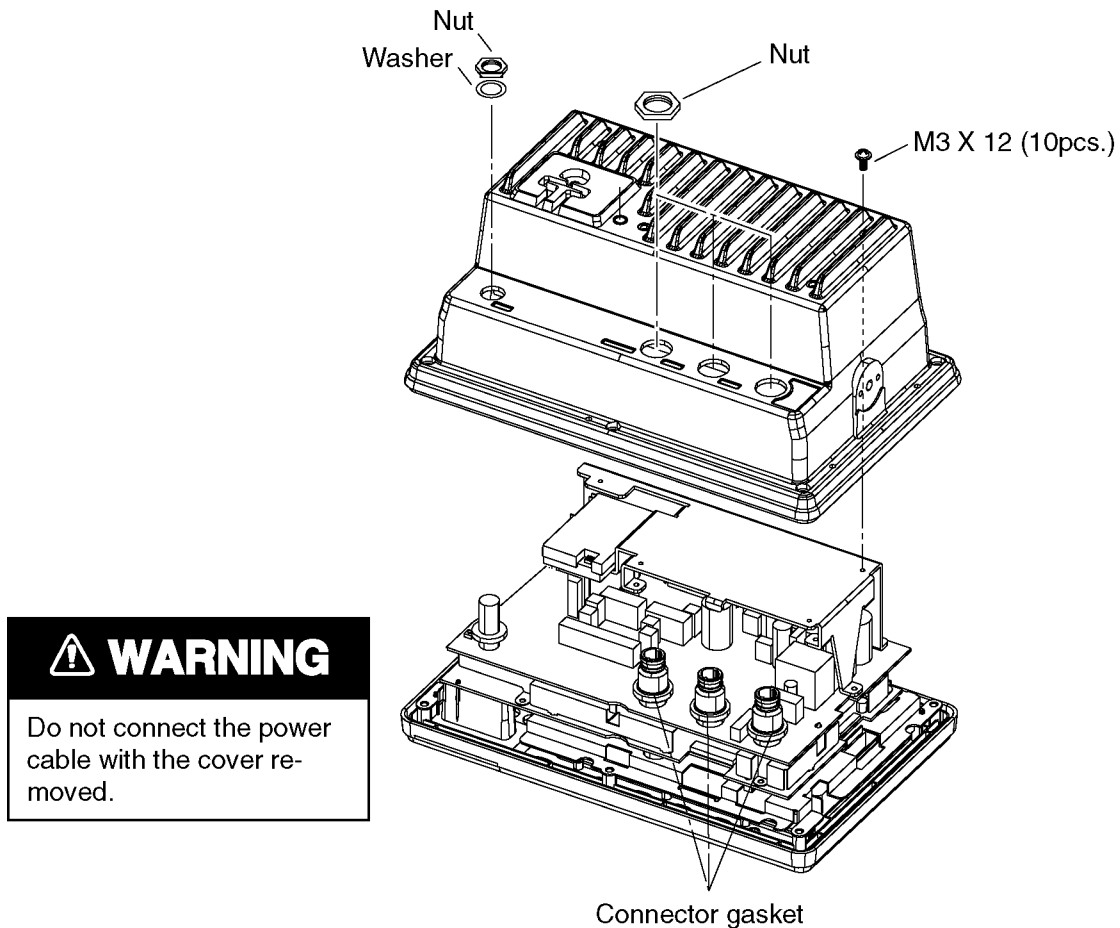

Removing cover assembly

3. Remove nut and washer attached to ANT connector.
4. Remove ten screws at rear of the display unit to detach panel/chassis assembly from the cover assembly.

Installation of beacon receiver

Procedure

1. Dismount chassis assembly from panel/chassis assembly by disconnecting the connector and PH8P from J8 on MAIN Board shown in the figure below.

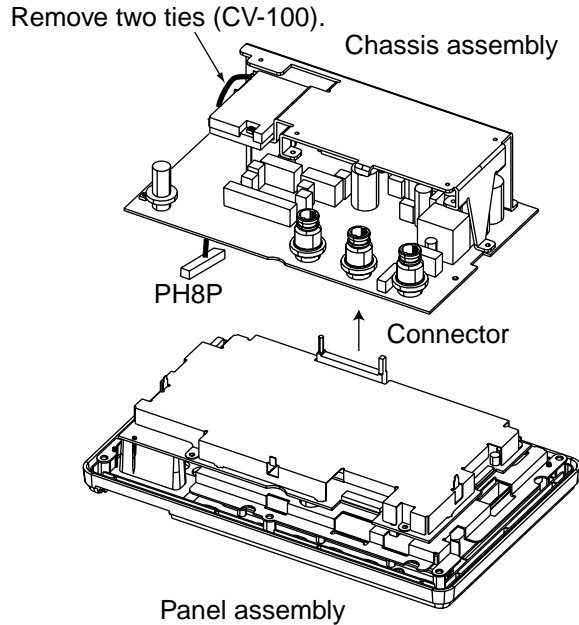

Dismounting chassis assembly

2. Dismount heat sink from chassis assembly by unfastening three screws on the ANLG board, loosening a screw at TR fixing plate and disconnecting the connector of the mini pin coax cable.

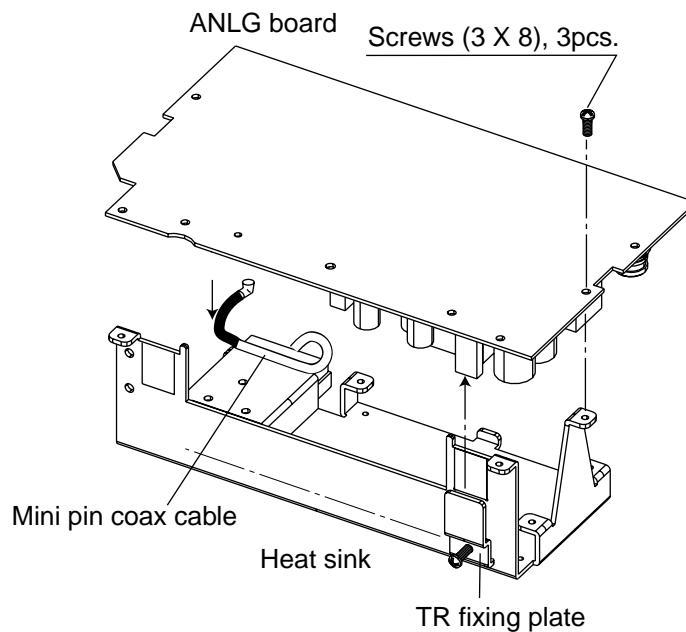

Chassis assembly

4. INCORPORATION OF DGPS BEACON RECEIVER KIT (for GP-1850W)

Handling of Coaxial Cable

- Do not touch the connector with bare hands; use gloves.
- Use radio pliers to remove, and pull out straightly.
- Plug in connector straightly.

3. Fasten the GR-7000A (DGPS beacon receiver) to the heat sink with four 3X8 screws as shown in the figure below.

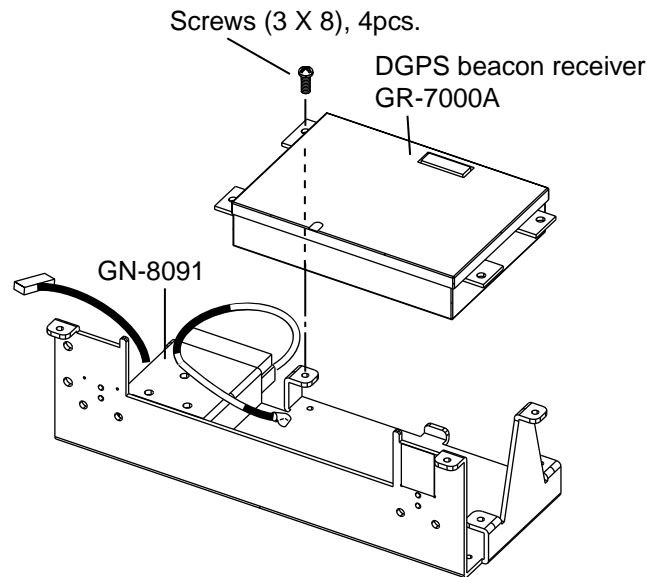

Installation of DGPS beacon receiver

4. Open the cover of GR-7000A to connect two coaxial cables shown below.

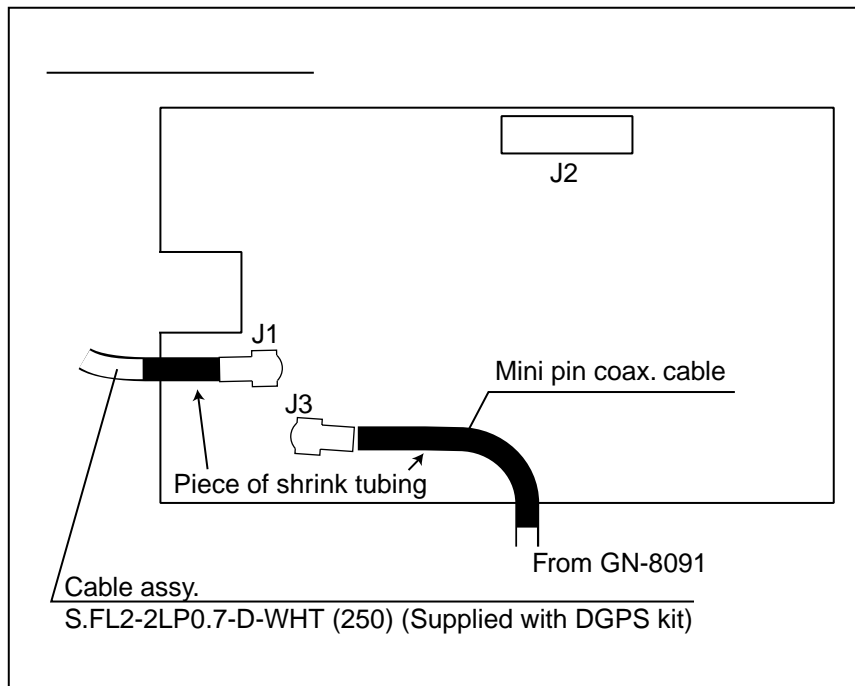

Connecting the coaxial cables in GR-7000A

4. INCORPORATION OF DGPS BEACON RECEIVER KIT (for GP-1850W)

5. Close the cover of GR-7000A passing the two cables out through respective notches in the cover.
6. Plug PH6P-W-L240 connector to J2 on the GR-7000A through the cover.
7. Wire cable assembly as shown in the figure below.

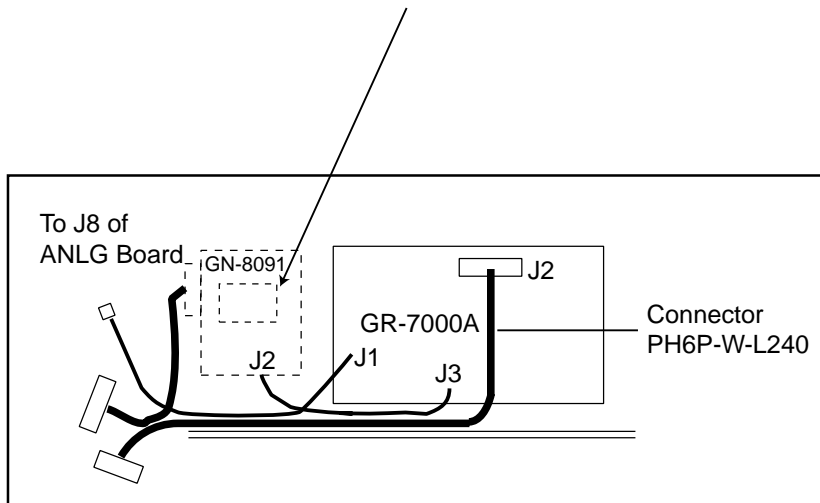
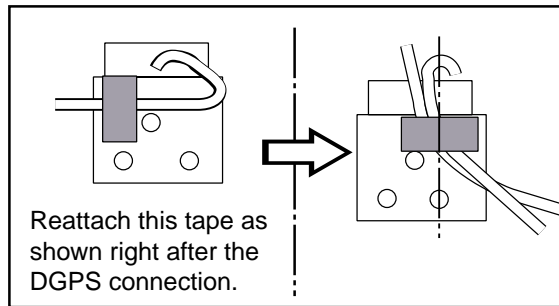

Wiring the Cable assembly

8. Mount the ANLG board on the heat sink referring to step 2. Fasten cable assy. S.FL2-2LP0.7-D-WHT (250), 8P connector cable and 6P connector cable by cable tie (CV-100, supplied) as shown in the figure below. Fix cable assy. S.FL2-2LP0.7-D-WHT (250) with the vinyl tape.

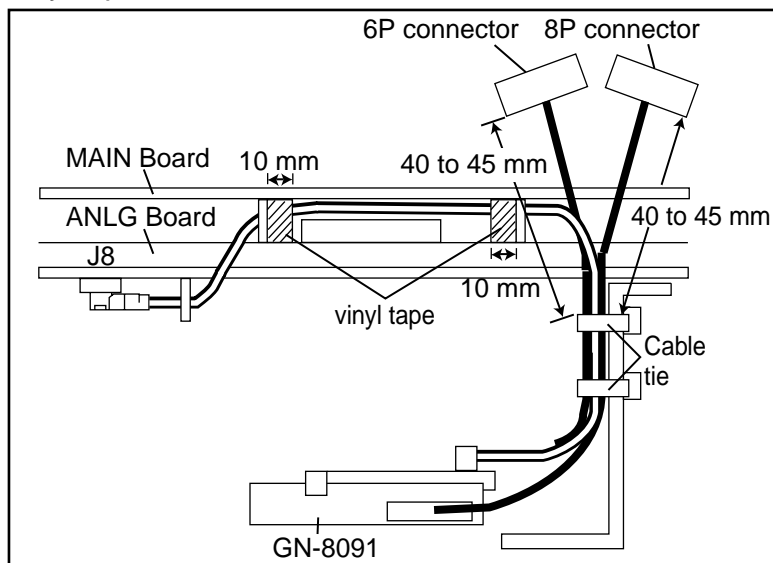

Attaching cable tie

4. INCORPORATION OF DGPS BEACON RECEIVER KIT (for GP-1850W)

9. Connect J1 of GR-7000A to J8 of ANLG board (Refer to previous page).

10. Mount chassis assembly on the panel assembly. Connect 8P connector and 6P connector to Main board as shown in the figure below.

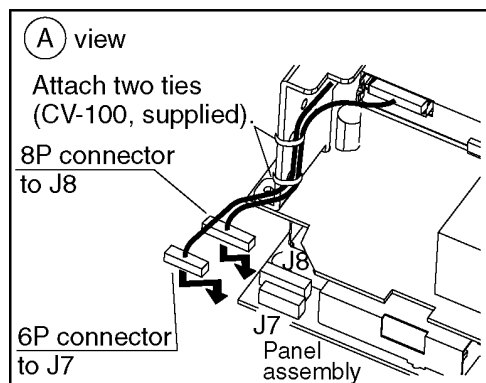
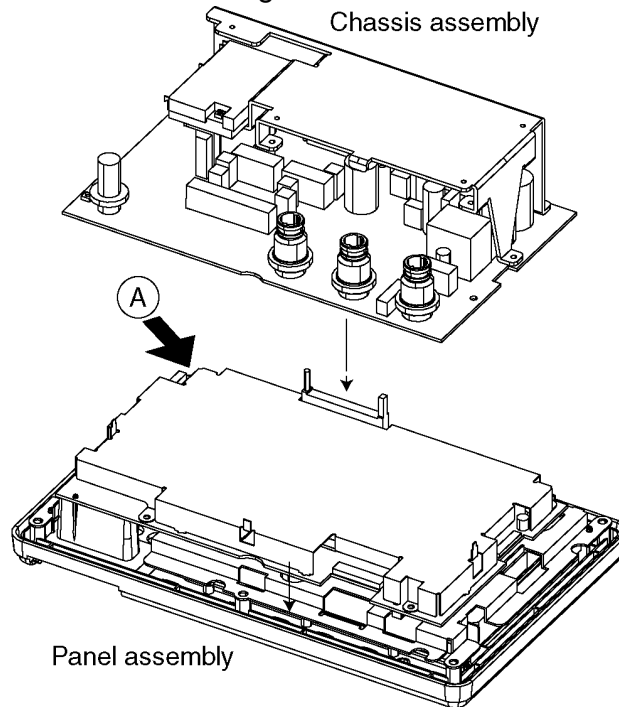

Attaching chassis assembly

11. Reassemble the display unit.

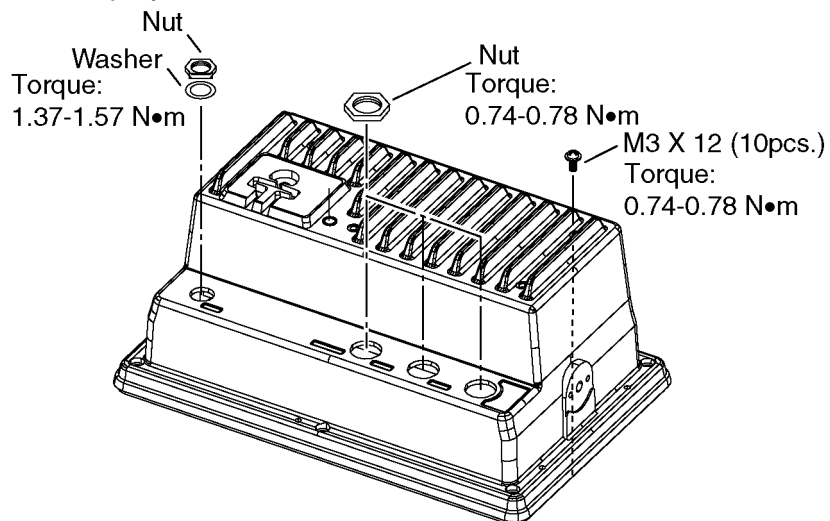

Remounting the cover

4. INCORPORATION OF DGPS BEACON RECEIVER KIT (for GP-1850W)

Note: When reattaching the cover, confirm the following parts are attached.

- Inside of the cover: Shield gasket, GN gasket (See the figure below.)
- On ANLG Board: Connector gasket (See the page 16.)

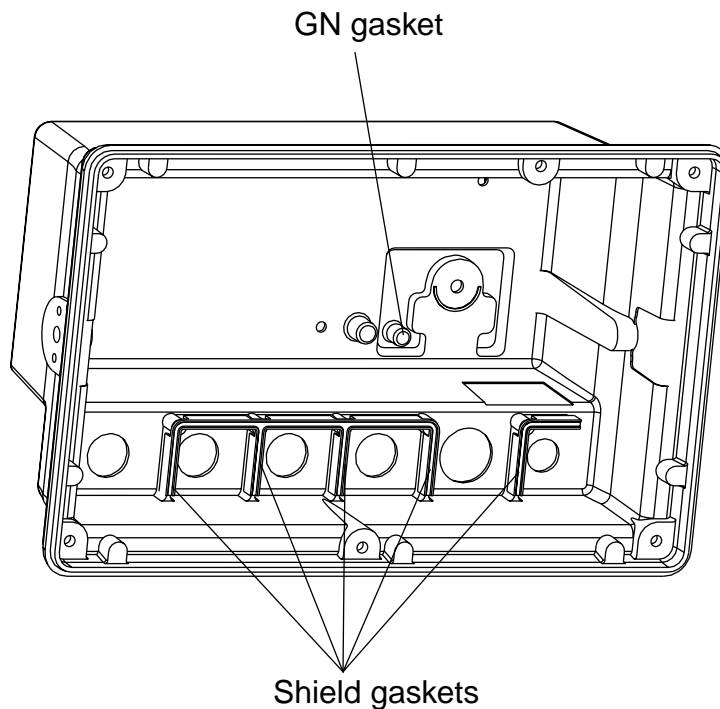

Checking the beacon receiver

1. Press the [MENU] key.
2. Press the CONFIGURATION soft key.
3. Press the SYSTEM MENU soft key.
4. Press the SELF TEST soft key.
5. Press the MEMORY•I/O TEST soft key to display the following message.

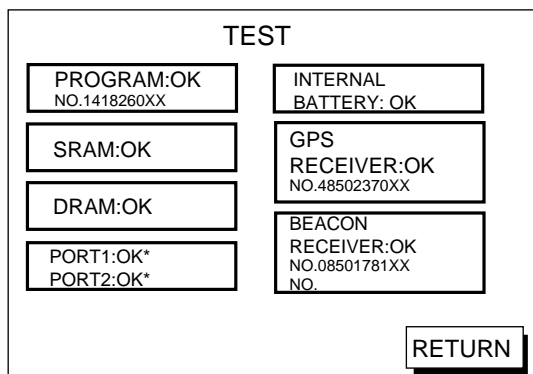

*Special connections are required to check these ports.
Otherwise, "--"(bar) appears.

Memory, I/O Test Display

6. Confirm that BEACON RECEIVER: OK is displayed.
7. Press the RETURN soft key.
8. Press the [PLOT] key to return the plotter display.

This page is intentionally left blank.

PACKING LIST GP-1850W (E017)

14CP-X-9852-0 1/1

NAME	OUTLINE	DESCRIPTION/CODE No.	Q'TY
ユニット UNIT			
指示器 DISPLAY UNIT		GP-1850W-E	1
空中線部 ANTENNA UNIT		000-041-808 GPA-017	1
予備品 SPARE PARTS			
SP14-02501			
ヒューズ FUSE		FGB0-A 5A AC125V	3
付属品 ACCESSORIES			
FP14-02401			
ハードカバー組品 HARD COVER ASSY.		FP14-02401	1
付属品 ACCESSORIES			
FP14-02403			
ナット WASHER HEAD SCREW		M4X20 SUS304	6
ナット +TAPPING SCREW		000-804-742 5X16 SUS304 1種	4
ゴムの足 RUBBER FOOT		000-805-494 TM-166 No. 18 4口	2
その他工材 OTHER INSTALLATION MATERIALS			

NAME	OUTLINE	DESCRIPTION/CODE No.	Q'TY
ケーブル組品MJ CABLE ASSY.		MJ-A6SPF0003-050	1
ケーブル組品MJ CABLE ASSY.		000-117-603 MJ-A3SPF0013-035	1



その他工材 OTHER INSTALLATION MATERIALS

PACKING LIST GP-1850WD (E019)

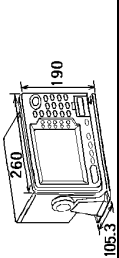
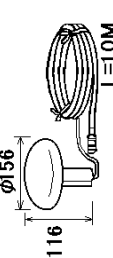
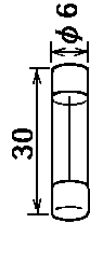
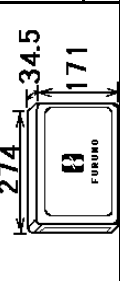
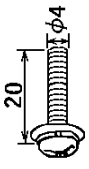
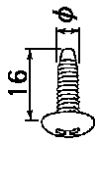
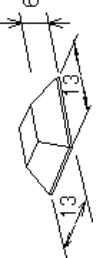
14CP-X-9855-0 1/1

NAME	OUTLINE	DESCRIPTION/CODE No.	Q'TY
ユニット UNIT			
指示器 DISPLAY UNIT		GP-1850WD-E	1
空中線部 ANTENNA UNIT		000-041-812 GPA-019	1
予備品 SPARE PARTS			
SP14-02501			
ヒューズ FUSE		FGB0-A 5A AC125V	3
付属品 ACCESSORIES			
FP14-02401			
ハードカバー組品 HARD COVER ASSY.		FP14-02401	1
付属品 ACCESSORIES			
FP14-02403			
ナット WASHER HEAD SCREW		M4X20 SUS304	6
ナット +TAPPING SCREW		000-804-742 5X16 SUS304 1種 000-805-494	4
ゴムの足 RUBBER FOOT		TM-166 No. 18 4口 000-808-732	2

その他工材 OTHER INSTALLATION MATERIALS



NAME	OUTLINE	DESCRIPTION/CODE No.	Q'TY
ケーブル組品MJ CABLE ASSY.		MJ-A6SPF0003-050 000-117-603	1
ケーブル組品MJ CABLE ASSY.		MJ-A3SPF0013-035 000-129-613	1

(略図の寸法は、参考値です。DIMENSIONS IN DRAWING FOR REFERENCE ONLY.)

PACKING LIST

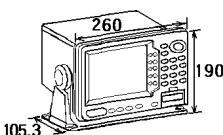
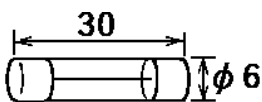
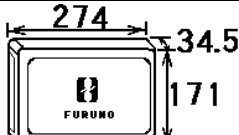
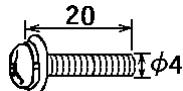
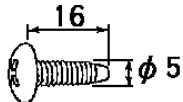

14CP-X-9857 -0 1/1

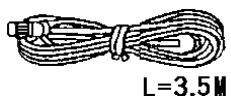
GP-1850WD (E)

NAME	OUTLINE	DESCRIPTION/CODE No.	Q'TY
ユニット UNIT			
指示器 DISPLAY UNIT		GP-1850WD-E 000-041-812	1
予備品 SPARE PARTS		SP14-02501	
ヒューズ FUSE		FGB0-A 5A AC125V 000-549-064	3
付属品 ACCESSORIES		FP14-02401	
ハードカバー組品 HARD COVER ASSY.		FP14-02401 004-375-270	1
付属品 ACCESSORIES		FP14-02403	
+ナベ セムスネジ B WASHER HEAD SCREW		M4X20 SUS304 000-804-742	6
+トラスタッピングネジ +TAPPING SCREW		5X16 SUS304 1種 000-805-494	4
ゴム足 RUBBER FOOT		TM-166 No. 18 4個 000-808-732	2
その他工材 OTHER INSTALLATION MATERIALS			
ケーブル組品MJ CABLE ASSY.		MJ-A6SPF0003-050 000-117-603	1
ケーブル組品MJ CABLE ASSY.		MJ-A3SPF0013-035 000-129-613	1

(略図の寸法は、参考値です。 DIMENSIONS IN DRAWING FOR REFERENCE ONLY.)

FURUNO

工事材料表 INSTALLATION MATERIALS		GP-80, GP-90, SC-55, GP-3500/F GP-1850, GP-1650, FA-100, GP-1640/F SC-60/120, GD/GP-280/680/380			20AG-X-9404 -1 1/1	
番号 NO.	名称 NAME	略図 OUTLINE	型名 / 規格 DESCRIPTIONS		数量 Q'TY	用途 / 備考 REMARKS
1	アンテナケーブル組品 ANTENNA CABLE ASSY.	 L=30M	8D-FB-CV *30M*		1	選択 TO BE SELECTED
			CODE NO.	000-111-547		
2	ケーブル組品 CABLE ASSY.	 L=50M	8D-FB-CV *50M*		1	選択 TO BE SELECTED
			CODE NO.	000-117-599		

FURUNO

CODE NO.	004-372-420	20AG-X-9405 -1
TYPE	CP20-01701	1/1

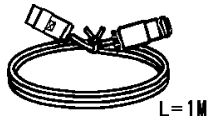
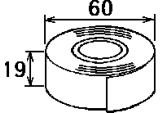
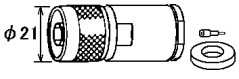
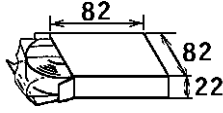
工事材料表 INSTALLATION MATERIALS					
番号 NO.	名称 NAME	略図 OUTLINE	型名 / 規格 DESCRIPTIONS	数量 Q'TY	用途 / 備考 REMARKS
1	変換ケーブル組品 CONVERT CABLE ASSY.		NJ-TP-3DXV-1	2	
			CODE NO. 000-123-809		
2	ビニールテープ VINYL TAPE		N0360 02X19X10000 加 工品	1	
			CODE NO. 000-835-215		
3	コネクタ(N) CONNECTOR		N-P-8DFB	1	
			CODE NO. 000-111-549		
4	絶縁テープ SELF-BONDING TAPE		Uテープ 0.5X19X5M	1	
			CODE NO. 000-800-985		



表1 TABLE 1

寸法区分 (mm) DIMENSION	公差 (mm) TOLERANCE
L ≤ 50	±1.5
50 < L ≤ 100	±2.5
100 < L ≤ 500	±3

表2 TABLE 2

機種名 MODEL	質量 MASS(kg)
GP-1850W	3.0
GP-1850WD	3.2

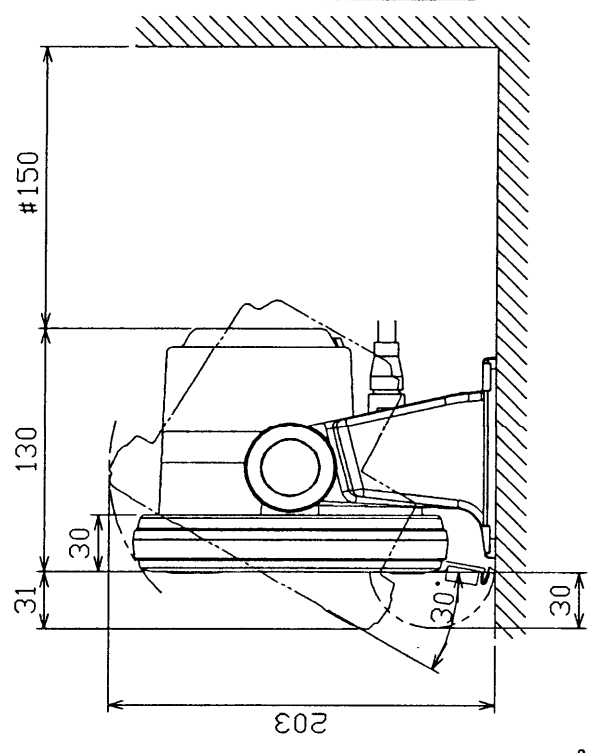
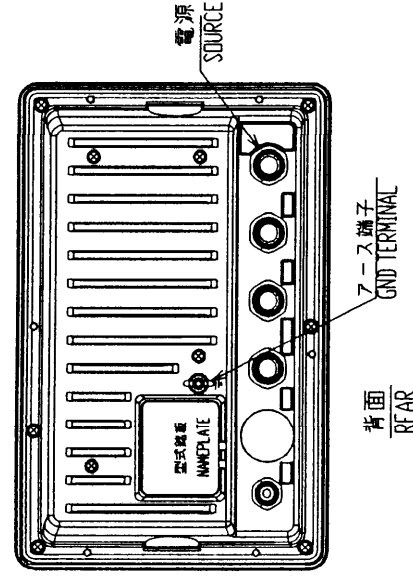
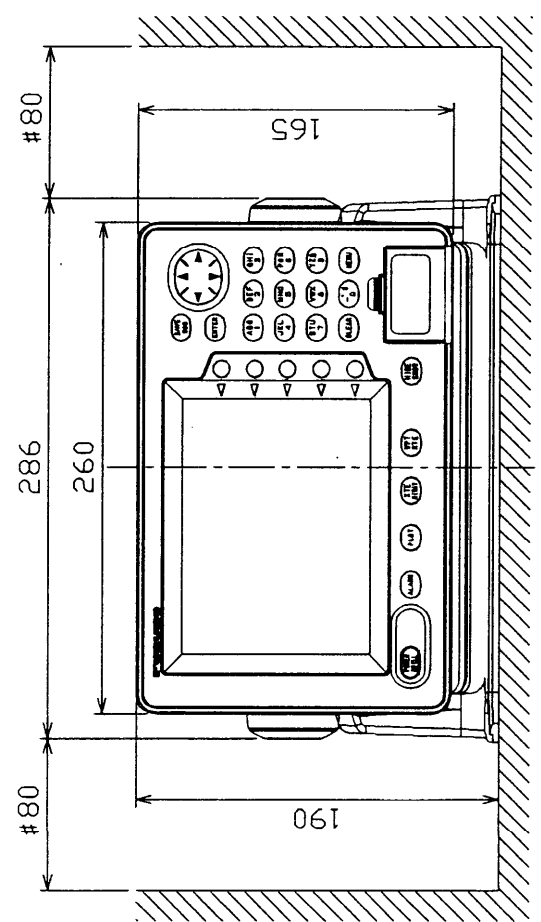
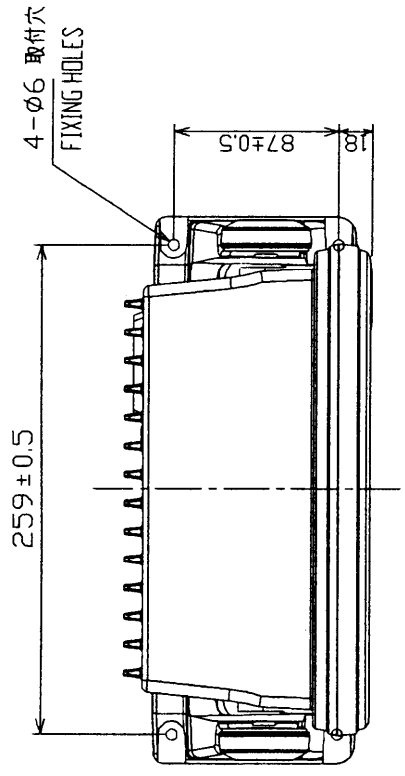

注記 1) 装備ケーブルはサービス時、指示部を前方に十分引き出せるよう余裕を持たせること。
 2) 取付用ネジはトラスタックピングネジ呼び径5×20を使用のこと。
 3) 指定外寸法公差は、表1による。
 4) #印寸法は最小サービス空間とする。

NOTE 1. KEEP SUFFICIENT CABLE LENGTH BEHIND UNIT.
 2. USE TAPPING SCREWS 5x20 FOR FIXING THE UNIT.
 3. TABLE 1 INDICATES TOLERANCE OF DIMENSIONS.
 4. #: RECOMMENDED SERVICE CLEARANCE.

DRAWN	July 9 '02	T. YAMASAKI	TITLE	GP-1850W/1850WD
CHECKED	July 9 '02	T. K. Iwano	名称	指示器
APPROVED	July 9 '02	T. K. Iwano	外形図	
SCALE	1/4	表2	NAME	DISPLAY UNIT
DWG No.	C4425-001-A			OUTLINE DRAWING
	14-062-120G-0			

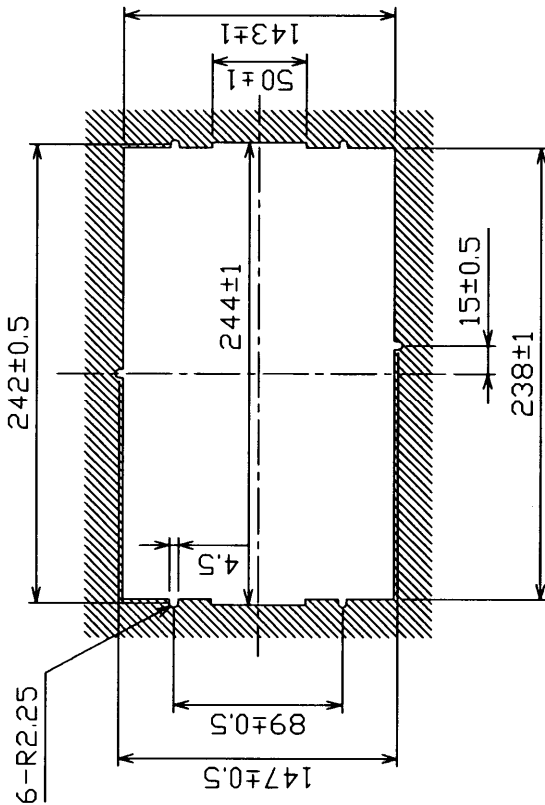
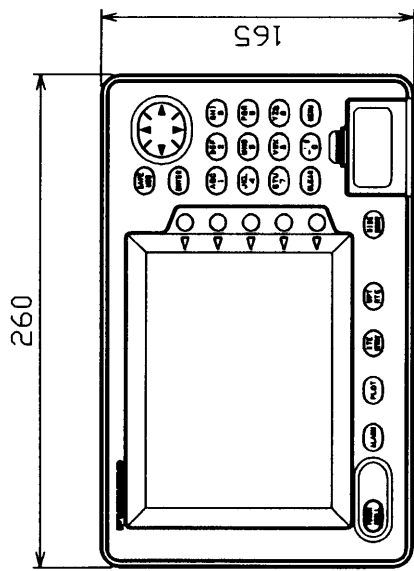

取付穴寸法図
CUTOUT DIMENSIONS

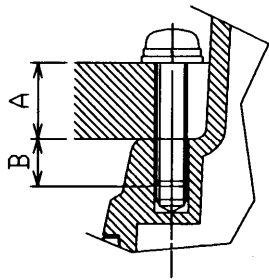
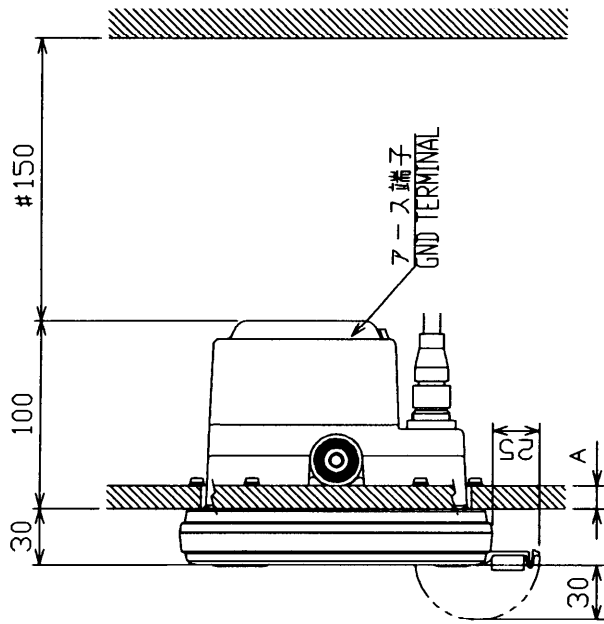

取付ネジ部断面
(尺度 1/1)
DETAIL FOR FASTENING (SCALE 1/1)

- 注記
- 1) 指定外寸法公差は表 1 による。
 - 2) # 印寸法は最小サービス空間とする。
 - 3) 取付用ネジは、セムスネジ B M4×2.0 を使用のこと。
壁の厚さ (A) は $1.1 \leq A \leq 1.4$ とする。それ以外の壁に装備する場合は、使用するネジ長さは $(A + 7.3) \pm 1.5$ とする。筐体にはネジ部を 7 mm 以上いれないこと。

- NOTE
1. TABLE 1 INDICATES TOLERANCE OF DIMENSIONS.
 2. # RECOMMENDED SERVICE CLEARANCE.
 3. USE SEMS SCREWS M4x2.0 FOR FIXING THE UNIT.
THICKNESS A: $1.1 \leq A \leq 1.4$ OR SCREW LENGTH: $(A+7.3) \pm 1.5$.
DO NOT FASTEN SCREWS INTO UNIT MORE THAN 7 mm.

機種名 MODEL	質量 MASS(kg)
GP-1850W	2.7
GP-1850WD	2.9
GP-1850WF	3.0
GP-1850WDF	3.1

表 2 TABLE 2

寸法区分 (mm) DIMENSION	公差 (mm) TOLERANCE
$L \leq 50$	± 1.5
$50 < L \leq 100$	± 2.5
$100 < L \leq 500$	± 3

表 1 TABLE 1

DRAWN Aug. 29 '02	T. YAMASAKI	TITLE	GP-1850W/1850WD/1850WF/1850WDF
CHECKED Aug. 29 '02	Y. K. I.	名称	指示器
APPROVED Aug. 29 '02	Y. K. I.	外形図	
SCALE 1/4	MASS 表 2	WAVE	DISPLAY UNIT
DWG No.	C4425-602-C		OUTLINE DRAWING

A

B

C

D

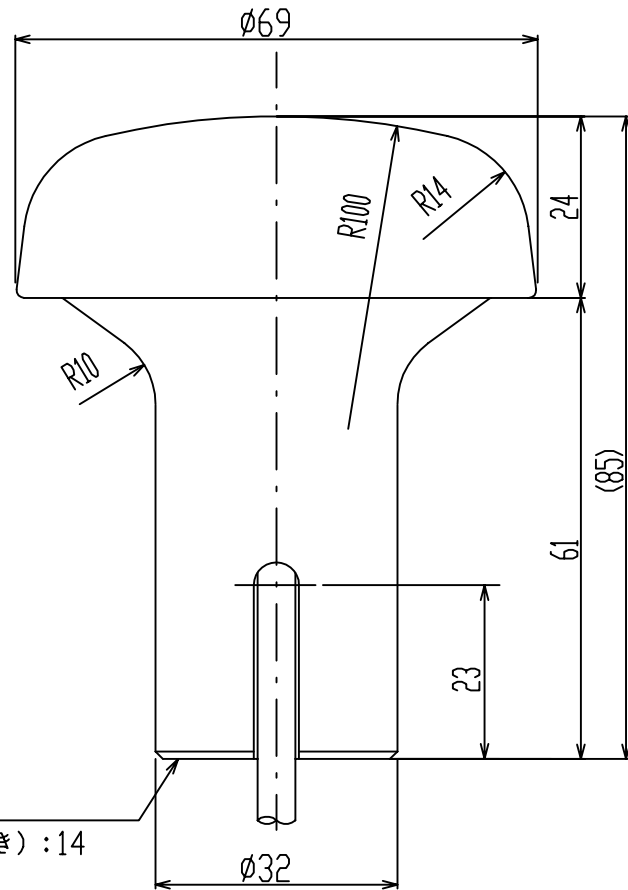

寸法区分(mm) DIMENSION	公差(mm) TOLERANCE
L ≤ 50	±1.5
50 < L ≤ 100	±2.5
100 < L ≤ 500	±3

表1 TABLE 1

1-14UNS1B

ねじ山数 (25.4mmにつき) : 14
 ピッチ : 1.8143 mm
 オネジ有効長さ : 24.17 mm
 オネジ有効径 : 19 mm以上

THREAD PER 25.4mm (1 INCH): 14
 PITCH: 1.8143 mm
 THREAD LENGTH: 15.17 mm
 PITCH DIAMETER: 24.17 mm

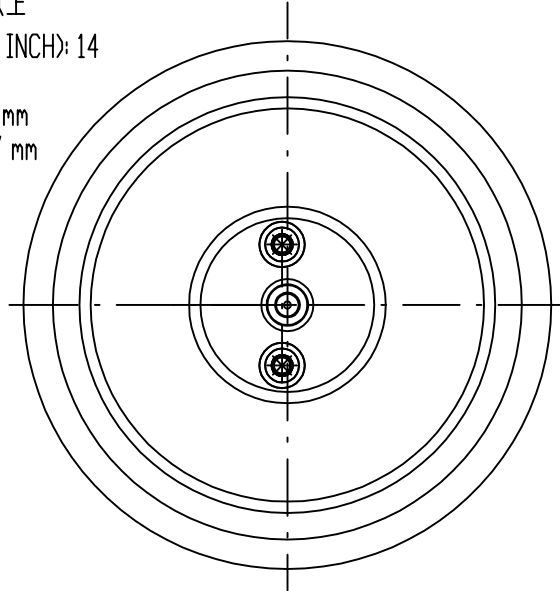

注記

指定外の寸法公差は表1による。

NOTE

TABLE 1 INDICATES TOLERANCE OF DIMENSIONS.

型式 TYPE	ケーブル長(m) CABLE LENGTH	プラグ PLAG	質量(kg±10%) MASS
GPA-017	10	TNC-P-3	0.6
GPA-017S	0.2	TNC-J-3	0.15

表2 TABLE 2

DRAWN Feb. 19 '03 T.YAMASAKI	TITLE GPA-017/017S
CHECKED Feb. 19 '03 Y.KIMURA	名称 空中線部
APPROVED Feb. 19, '03 <i>Y. Kimura</i>	外寸図
SCALE 1/1 MASS TABLE 2 表2参照	NAME ANTENNA UNIT
DWG.No. C4384-G04-J	OUTLINE DRAWING

寸法区分(mm) DIMENSION	公差(mm) TOLERANCE
L ≤ 50	±1.5
50 < L ≤ 100	±2.5
100 < L ≤ 500	±3

表1 TABLE 1

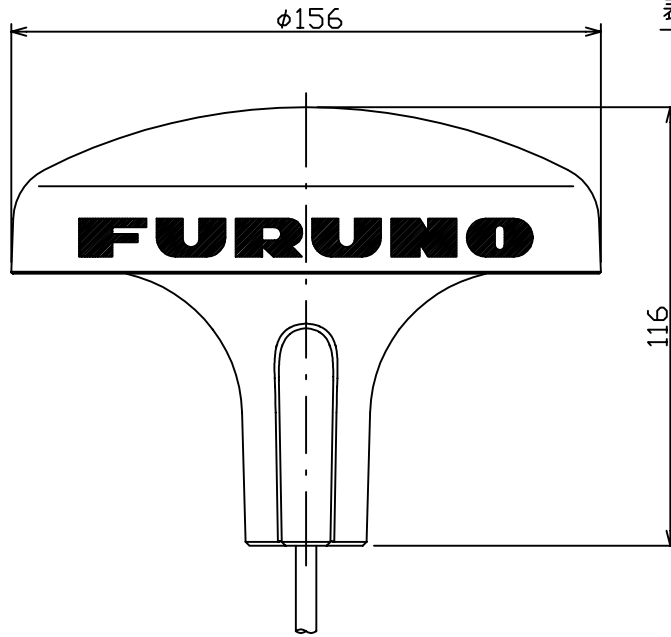

1-14UNS1B

ねじ山数(25.4mmにつき): 14
 ピッチ: 1.8143 mm
 オネジ有効長さ: 15.17 mm
 オネジ有効径: 24.17 mm

THREAD PER 25.4mm (1 INCH): 14
 PITCH: 1.8143 mm
 THREAD LENGTH: 15.17 mm
 PITCH DIAMETER: 24.17 mm

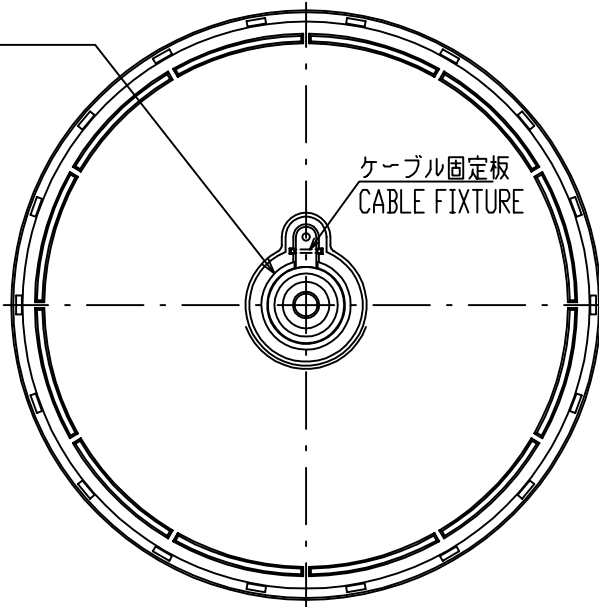

型式 TYPE	ケーブル長(m) CABLE LENGTH	プラグ PLAG	質量 (kg±10%) MASS
GPA-019	10	TNC-P-3	1.0
GPA-019S	0.2	TNC-J-3	0.54

表2 TABLE 2

注記: 指定外の寸法公差は表1による

NOTE: TABLE 1 INDICATES TOLERANCE OF DIMENSIONS.

DRAWN Feb. 19 '03 T.YAMASAKI	TITLE GPA-019/019S
CHECKED Feb. 19 '03 Y.KIMURA	名称 空中線部
APPROVED Feb. 19, '03 <i>Y. Kimura</i>	外寸図
SCALE 1/2 MASS TABLE 2 表2参照	NAME ANTENNA UNIT
DWG. No. C4400-G01-F	OUTLINE DRAWING

取付場所
MOUNTING LOCATION

他の機器のアンテナから下の図の距離以上離す。
THIS FIGURE SHOWS THE SEPARATION DISTANCES FROM OTHER ANTENNAS TO AVOID MUTUAL INTERFERENCE.

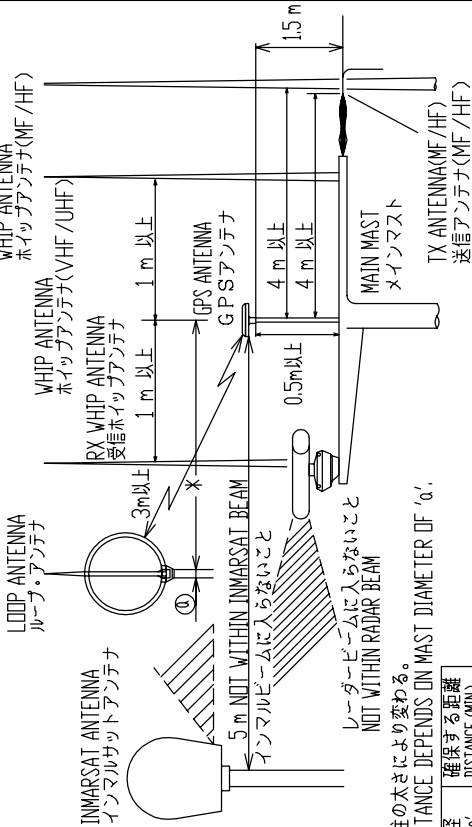

* : 支柱の太さにより変わる。
* : DISTANCE DEPENDS ON MAST DIAMETER OF 'α'.

φの直径 DIA. OF 'α'	確保する距離 DISTANCE (MIN)
10 cm	1.5 m
30 cm	3 m

B) スタンションやパルピットにつけるとき
レール用アンテナベース No.13-RC5160
(取付可能レール直径:φ19~φ32)
(コード番号: 000-806-114)

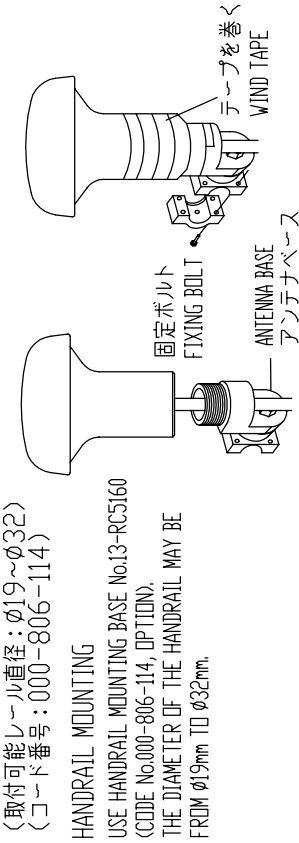

注記 1) パイプやアンテナベースはアンテナユニットにねじ込んだ後に固定する。
2) アンテナを固定するときはパイプ(アンテナベース)をアンテナにねじ込むこと。
アンテナ側をねじるとコネクタ部やケーブルに無理がかかり、故障の原因となる。

NOTE 1. FASTEN PIPE(ANTENNA BASE) TO ANTENNA UNIT FIRST THEN FIX THEM TO MAST OR HANDRAIL.
2. WHEN FIXING ANTENNA, TURN PIPE OR ANTENNA BASE, NOT THE ANTENNA.
TURNING THE ANTENNA MAY TWIST THE CABLE AND PLACE STRESS ON CONNECTOR.

A) マストへの取付け
MAST MOUNTING

α) マスト取付金具CP20-0111(工事材料)でマストに固定する。
USE MAST MOUNTING KIT CP20-0111.

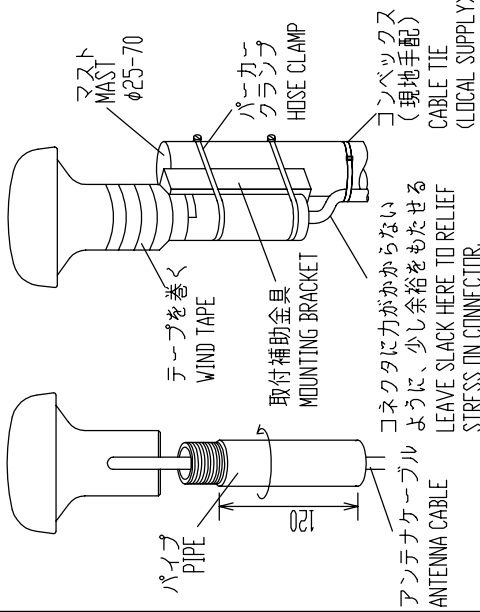

β) パイプのみを使うとき
USE A PIPE ONLY.

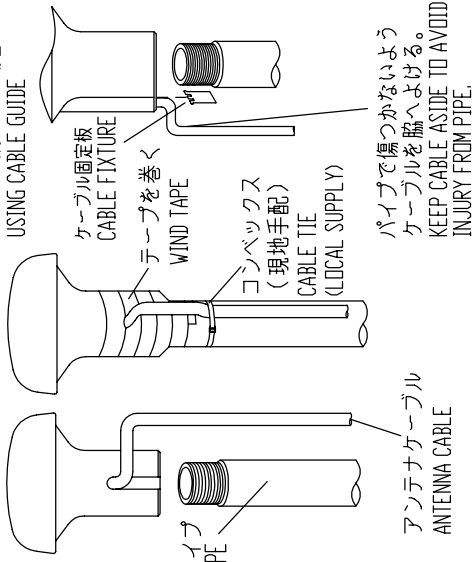

C) 取付ける場所が傾斜しているとき
ANTENNA BASE MOUNTING

オプションのアンテナベースを使う。
USE OPTIONAL ANTENNA BASE.

傾斜 INCLINATION	5° - 33°	32° - 65°	65° - 98°
装備方法 MOUNTING METHOD			
アンテナ ベース型式 ANT. BASE TYPE	直型アンテナベース RIGHT ANGLE ANTENNA BASE No.13-QA330	L型アンテナベース L-TYPE ANTENNA BASE No.13-QA310	L型アンテナベース L-TYPE ANTENNA BASE No.13-QA310
コード番号 CODE No.	000-803-239	000-803-240	000-803-240

アンテナベース基部
MOUNTING DIMENSIONS OF ANTENNA BASE.

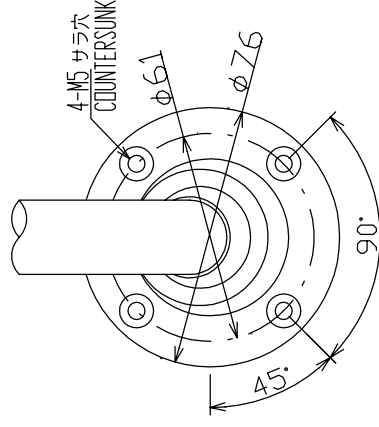

DRAWN	Jan. 5 '04	T. YAMASAKI	TITLE	GPA series
CHECKED	Jan. 5 '04	T. TAKENO	名称	空中線部
APPROVED	Jan. 5 '04	H. Hayashi	装備要領図	
SCALE		MASS	NAME	ANTENNA UNIT
DWG.No.		C4384-Y01-B	INSTALLATION PROCEDURE	



表1 TABLE 1

寸法区分(mm) DIMENSION	公差(mm) TOLERANCE
0 < L ≤ 50	±1.5
50 < L ≤ 100	±2.5
100 < L ≤ 500	±3

ケーブル導入口
CABLE ENTRY

24VDC
OUTPUT
(2.5A max)

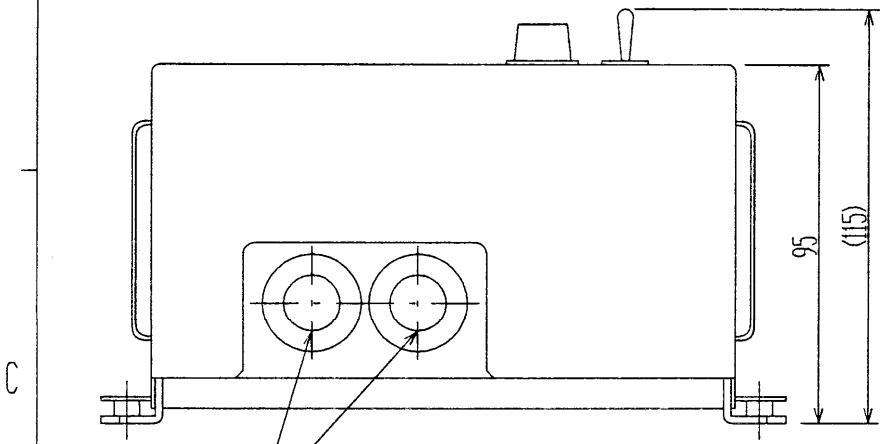
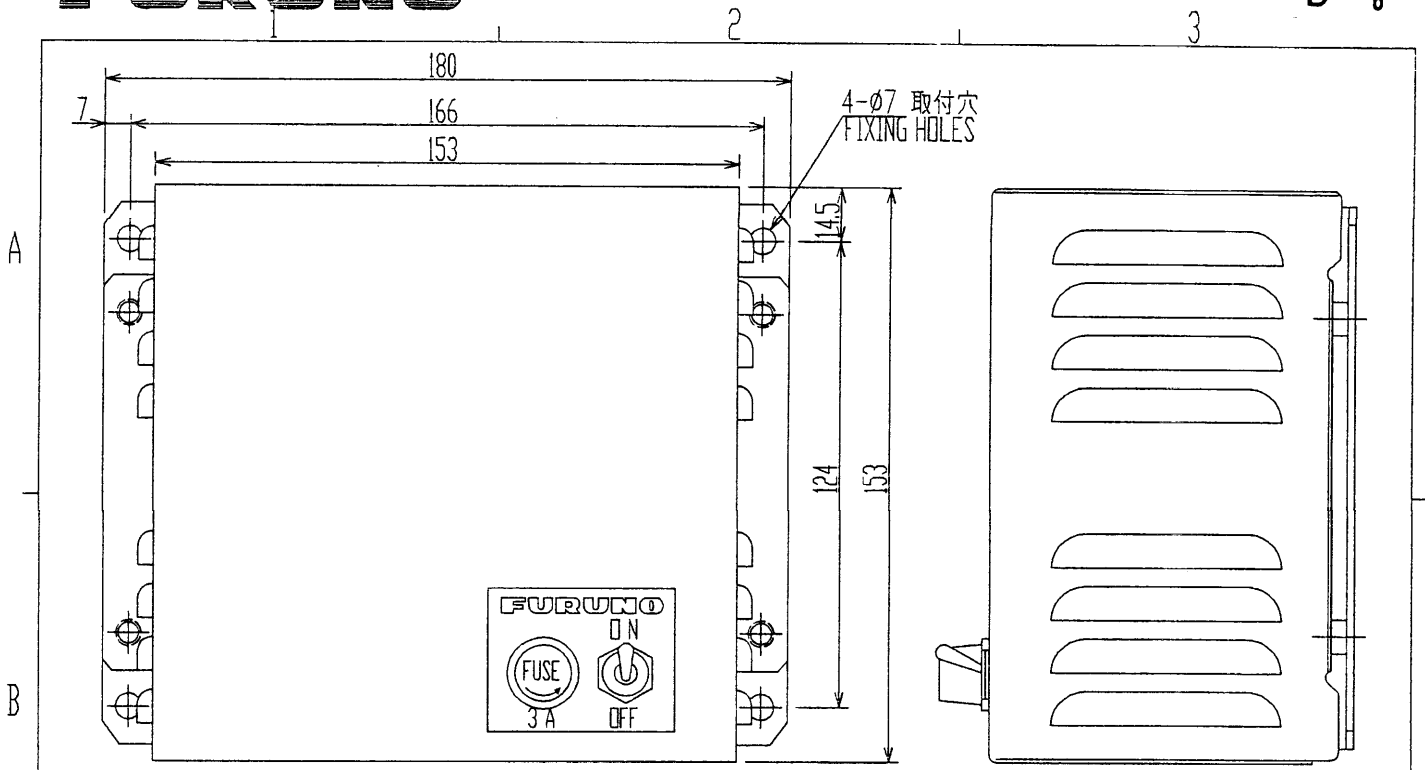
AC INPUT

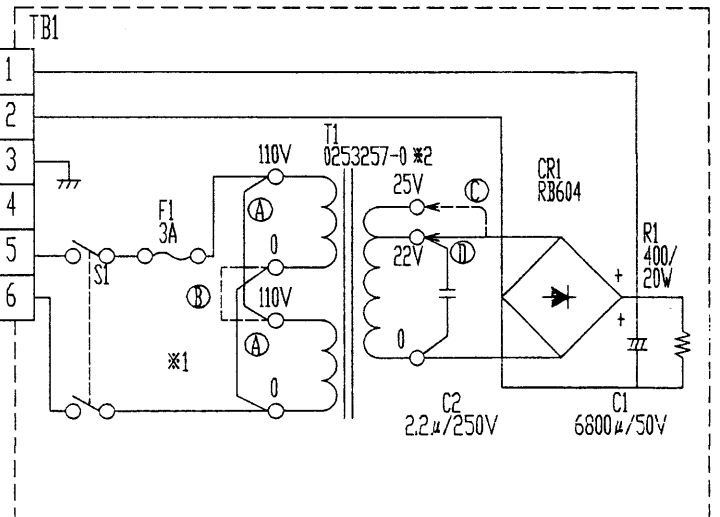

入力電圧に応じて接続を変更して下さい。
CHANGE TAP CONNECTIONS DEPENDING ON SUPPLY VOLTAGE.

	AC100V	AC110/ 115V	AC220V	AC230V
※1	(A)	(A)	(B)	(B)
※2	(C)	(D)	(D)	(D)

DRAWN Sep. 14 '01 T.YAMASAKI	TITLE PR-62
CHECKED S. YAMASAKI	名称 整流器
APPROVED S. YAMASAKI	外寸図
SCALE 1/2 MASS 3 ±10% kg	NAME RECTIFIER
DWG.No. C5003-034-E	OUTLINE DRAWING

ECF

(Elemental Chlorine Free)

The paper used in this manual
is elemental chlorine free.

© **FURUNO ELECTRIC CO., LTD.**

9-52 Ashihara-cho,
Nishinomiya, 662-8580, JAPAN

Telephone : +81-(0) 798-65-2111

Fax : +81-(0) 798-65-4200

• FURUNO Authorized Distributor/Dealer

All rights reserved. Printed in Japan

Pub. No. IME-44250-A2

(YOSH) GP-1850W/1850WD

A : AUG. 2002

A2 : AUG. 27, 2004



* 0 0 0 8 0 9 3 6 7 1 0 *