



# Dell™ Dimension™ C521 Service Manual

[Before You Begin](#)  
[About Your Computer](#)  
[Technical Overview](#)  
[Removing the Computer Cover](#)  
[Specifications](#)  
[Troubleshooting](#)  
[System Setup](#)  
[Removing and Installing Parts](#)  
[Replacing the Computer Cover](#)

---

## Notes, Notices, and Cautions

-  **NOTE:** A NOTE indicates important information that helps you make better use of your computer.
  -  **NOTICE:** A NOTICE indicates either potential damage to hardware or loss of data and tells you how to avoid the problem.
  -  **CAUTION:** A CAUTION indicates a potential for property damage, personal injury, or death.
- 

Information in this document is subject to change without notice.  
© 2006 Dell Inc. All rights reserved.

Reproduction in any manner whatsoever without the written permission of Dell Inc. is strictly forbidden.

Trademarks used in this text: *Dell*, the *DELL* logo, and *Dimension* are trademarks of Dell Inc.; *AMD*, *AMD Athlon*, and combinations thereof, *Sempron*, and *Cool 'n' Quiet* are trademarks of Advanced Micro Devices, Inc; *Microsoft* and *Windows* are registered trademarks of Microsoft Corporation.

Other trademarks and trade names may be used in this document to refer to either the entities claiming the marks and names or their products. Dell Inc. disclaims any proprietary interest in trademarks and trade names other than its own.

September 2006 Rev. A00

## About Your Computer

### Dell™ Dimension™ C521 Service Manual

- [Front View](#)
- [Back View of the Computer](#)
- [Back Panel I/O Connectors](#)

### Front View

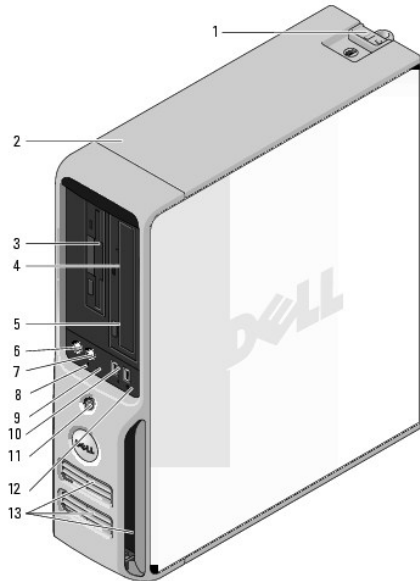

1	cover release latch	Use this latch to remove the cover. See <a href="#">Removing the Computer Cover</a> .
2	Service Tag	Use to identify your computer when you access the Dell Support website or call support.
3	FlexBay drive	Can contain an optional floppy drive or optional Media Card Reader.
4	CD or DVD activity light	The drive light is on when the computer reads data from the CD or DVD drive.
5	CD or DVD eject button	Press to eject a disk from the CD or DVD drive.
6	microphone connector	Use the microphone connector to attach a personal computer microphone for voice or musical input into a sound or telephony program.
7	headphone connector	Use the headphone connector to attach headphones and most kinds of speakers.
8	LAN activity light	This light indicates that a LAN (Local Area Network) connection is established.
9	diagnostic lights (4)	Use the lights to help you troubleshoot a computer problem based on the diagnostic code. For more information, see <a href="#">Diagnostic Lights</a> .
10	USB 2.0 connectors (2)	Use the front USB connectors for devices that you connect occasionally, such as joysticks or cameras, or for bootable USB devices. See <a href="#">System Setup Options</a> for more information on booting to a USB device. It is recommended that you use the back USB connectors for devices that typically remain connected, such as printers and keyboards.
11	power button	Press to turn on the computer.   <b>NOTICE:</b> To avoid losing data, do not use the power button to turn off the computer. Instead, perform an operating system shutdown.
12	hard-drive activity light	The hard drive activity light is on when the computer reads data from or writes data to the hard drive. The light might also be on when a device such as a CD player is operating.
13	vents	To ensure adequate cooling, do not block any of the vents.

- ➔ **NOTICE:** Ensure that there is a minimum of two inches of space between all vents and any object near these vents.
- ➔ **NOTICE:** Keep the vent area clean and dust-free to ensure that the system is adequately ventilated. Use only a dry cloth to clean the vent area to avoid water damage to the system.

## Back View of the Computer

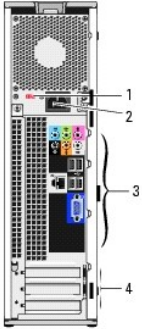

1	voltage selection switch	See the safety instructions in the <i>Product Information Guide</i> for more information.
2	power connector	Insert the power cable.
3	back panel I/O connectors	Plug VGA, USB, and other devices into the appropriate connectors. See <a href="#">Back Panel I/O Connectors</a> .
4	card slots (3)	Access connector slots for expansion cards: <ul style="list-style-type: none"> <li>1 SLOT1 PCI Express x16</li> <li>1 SLOT2 PCI Express x1</li> <li>1 SLOT3 PCI</li> </ul>

## Back Panel I/O Connectors

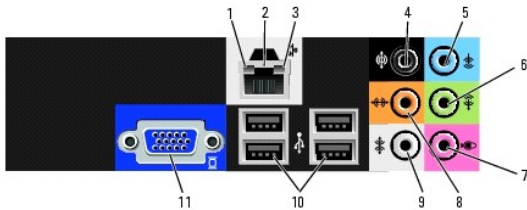

1	link integrity light	<ul style="list-style-type: none"> <li>1 Green — A good connection exists between a 10-Mbps network and the computer.</li> <li>1 Orange — A good connection exists between a 100-Mbps network and the computer.</li> <li>1 Off — The computer is not detecting a physical connection to the network.</li> </ul>
2	network adapter connector	<p><b>NOTICE:</b> Do not plug a telephone cable into the network connector.</p> <p>Use the network adapter connector to attach your computer to a network or broadband device. Connect one end of a network cable to either a network jack or your network or broadband device, and then connect the other end of the network cable to the network adapter connector on your computer. A click indicates that the network cable has been securely attached.</p> <p>On computers with an additional network connector card, use the connectors on the card and on the back of the computer when setting up multiple network connections (such as a separate intra- and extranet).</p>

		<p><b>NOTE:</b> It is recommended that you use Category 5 wiring and connectors for your network. If you must use Category 3 wiring, force the network speed to 10 Mbps to ensure reliable operation.</p>
3	network activity light	Flashes a yellow light when the computer is transmitting or receiving network data. A high volume of network traffic may make this light appear to be in a steady "on" state.
4	surround sound connector	Use the (black) surround sound connector to attach multichannel-capable speakers.  On computers with a sound card, use the connector on the card.
5	line-in connector	Use the (blue) line-in connector to attach a record/playback device such as a cassette player, CD player, or VCR.  On computers with a sound card, use the connector on the card.
6	line-out/headphone connector	Use the (green) line-out connector to attach headphones and most speakers with integrated amplifiers.  On computers with a sound card, use the connector on the card.
7	microphone connector	Use the (pink) microphone connector to attach a personal computer microphone for voice or musical input into a sound or telephony program.  On computers with a sound card, use the connector on the card.
8	center/subwoofer LFE connector	Use the (orange) center/subwoofer connector to attach a center speaker or a single subwoofer.  On computers with a sound card, use the connector on the card.  <b>NOTE:</b> The LFE (Low Frequency Effects) Audio channel, found in digital surround sound audio schemes, carries only low frequency information of 80 Hz and below. The LFE channel drives a subwoofer to provide extremely low bass extension. Systems not using subwoofers can shunt the LFE information to the main speakers in the surround sound setup.
9	side surround sound connector	Use the (gray) side surround sound connector to attach multichannel-capable speakers. The side-surround output provides enhanced surround audio for computers with 7.1 speakers.  On computers with a sound card, use the connector on the card.
10	USB 2.0 connectors (4) (rear quad)	Use the back, rear-quad USB connectors for devices that typically remain connected, such as printers and keyboards.  <b>NOTE:</b> It is recommended that you use the front USB connectors for devices that you connect occasionally, such as joysticks, cameras, or bootable USB devices.
11	VGA video connector	If your monitor has a VGA connector, plug it into the VGA connector on the computer.  <b>NOTE:</b> If your computer has an add-in video card, connect your monitor to the add-in card's video connector.

---

[Back to Contents Page](#)

## Before You Begin

### Dell™ Dimension™ C521 Service Manual

- [Getting Started](#)
  - [Recommended Tools](#)
  - [Turning Off Your Computer](#)
  - [Before Working Inside Your Computer](#)
- 

## Getting Started

This manual provides procedures for removing and replacing the components in your computer. Unless otherwise noted, each procedure assumes that the following conditions exist:

- 1 You have performed the steps in [Turning Off Your Computer](#) and [Before Working Inside Your Computer](#).
  - 1 You have read the safety information in your Dell™ *Product Information Guide*.
  - 1 A component can be replaced by performing the removal procedure in reverse order. Directional instructions are also performed on the reverse.
- 

## Recommended Tools

The procedures in this document may require the following tools:

- 1 Small flat-blade screwdriver
  - 1 Phillips #0, #1, and #2 screwdrivers
  - 1 Flash BIOS update program (download from [support.dell.com](http://support.dell.com))
- 

## Turning Off Your Computer

➡ **NOTICE:** To avoid losing data, save and close any open files and exit any open programs before you turn off your computer.

1. Shut down the operating system:
  - a. Save and close any open files, exit any open programs, click the **Start** button, and then click **Shut Down**.
  - b. In the **Shut Down Windows** window, select **Shut Down**.

The computer turns off after the operating system shutdown process finishes.

2. Ensure that the computer and any attached devices are turned off. If your computer and attached devices did not automatically turn off when you shut down your operating system, press and hold the power button for 4 seconds.
- 

## Before Working Inside Your Computer

Use the following safety guidelines to help protect your computer from potential damage and to help ensure your own personal safety.

⚠ **CAUTION:** Before you begin any of the procedures in this section, follow the safety instructions in the **Product Information Guide**.

⚠ **CAUTION:** Handle components and cards with care. Do not touch the components or contacts on a card. Hold a card by its edges or by its metal mounting bracket. Hold a component such as a processor by its edges, not by its pins.

➡ **NOTICE:** Only a certified service technician should perform repairs on your computer. Damage due to servicing that is not authorized by Dell is not covered by your warranty.

➡ **NOTICE:** When you disconnect a cable, pull on its connector or on its strain-relief loop, not on the cable itself. Some cables have a connector with locking tabs; if you are disconnecting this type of cable, press in on the locking tabs before you disconnect the cable. As you pull connectors apart, keep them evenly aligned to avoid bending any connector pins. Also, before you connect a cable, ensure that both connectors are correctly oriented and aligned.

➡ **NOTICE:** To avoid damaging the computer, perform the following steps before you begin working inside the computer.

1. Follow the steps in [Turning Off Your Computer](#).

 **NOTICE:** To disconnect a network cable, first unplug the cable from your computer and then unplug it from the network port or device.

2. Disconnect any telephone or network cables from the computer.
3. Disconnect your computer and all attached devices from their electrical outlets, and then press the power button to ground the system board.

 **CAUTION:** To guard against electrical shock, always unplug your computer from the electrical outlet before opening the cover.

4. Follow the steps in [Removing the Computer Cover](#).

 **NOTICE:** Before touching anything inside your computer, ground yourself by touching an unpainted metal surface, such as the metal at the back of the computer. While you work, periodically touch an unpainted metal surface to dissipate any static electricity that could harm internal components.

---

[Back to Contents Page](#)

## Replacing the Computer Cover

Dell™ Dimension™ C521 Service Manual

**⚠ CAUTION:** Before you begin any of the procedures in this section, follow the safety instructions located in the *Product Information Guide*.

1. Ensure that all cables are connected, and fold cables out of the way.  
Gently pull the power cables toward you so that they do not get caught underneath the drives.
2. Ensure that no tools or extra parts are left inside the computer.

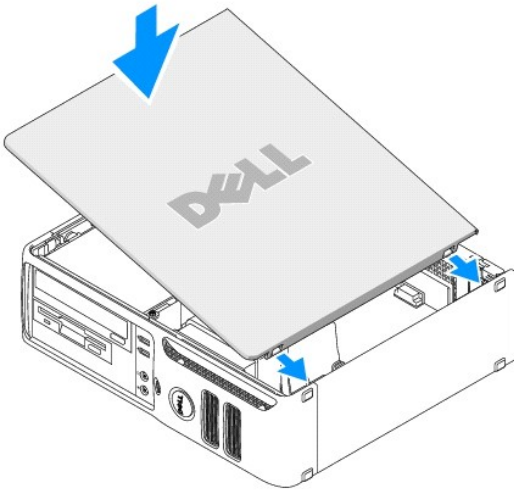



3. To replace the cover:
  - a. Align the bottom of the cover with the hinge tabs located along the bottom edge of the computer.
  - b. Using the hinge tabs as leverage, rotate the cover downward to close it.
  - c. Press the cover down until it snaps into place.
  - d. Ensure that the cover is seated correctly before moving the computer.

**➡ NOTICE:** To connect a network cable, first plug the cable into the network port or device, and then plug it into the computer.



4. Connect your computer and devices to electrical outlets, and then turn them on.

## Removing the Computer Cover

### Dell™ Dimension™ C521 Service Manual

-  **CAUTION:** Before you begin any of the procedures in this section, follow the safety instructions in the *Product Information Guide*.
-  **CAUTION:** To guard against electrical shock, always unplug your computer from the electrical outlet before opening the cover.
-  **NOTICE:** Before touching anything inside your computer, ground yourself by touching an unpainted metal surface, such as the metal at the back of the computer. While you work, periodically touch an unpainted metal surface to dissipate any static electricity that could harm internal components.

1. Follow the procedures in [Before You Begin](#).

-  **NOTICE:** Ensure that sufficient space exists to support the removed cover—at least 30 cm (1 ft) of desk top space.
-  **NOTICE:** Ensure that you are working on a level, protected surface to avoid scratching either the computer or the surface on which it is resting.

2. If you have installed a padlock through the padlock ring on the back panel, remove the padlock.

3. Locate the cover release latch shown in the illustration. Then, slide the release latch back as you lift the cover.

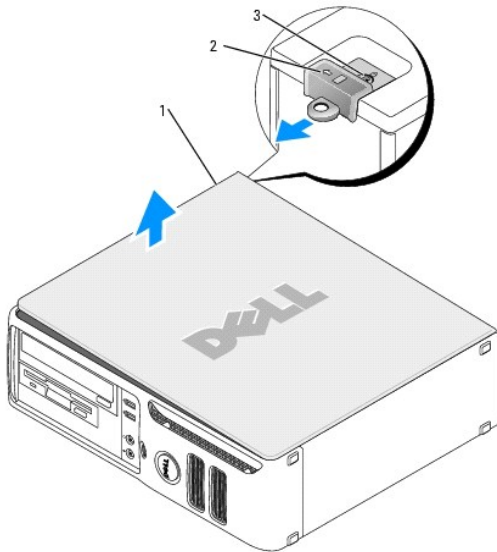

1	computer cover	2	cover release latch	3	security cable slot
---	----------------	---	---------------------	---	---------------------

4. Grip the sides of the computer cover and pivot the cover up using the hinge tabs as leverage points.
5. Remove the cover from the hinge tabs and set it aside on a soft nonabrasive surface.



## Removing and Installing Parts

### Dell™ Dimension™ C521 Service Manual

- [Memory](#)
- [Cards](#)
- [Drives](#)
- [CD/DVD Drive](#)
- [Floppy Drive](#)
- [Media Card Reader](#)
- [Hard Drive](#)
- [Battery](#)
- [Processor](#)
- [Power Supply](#)
- [Front I/O Panel](#)
- [Fan Assembly](#)
- [System Board](#)

## Memory

If your computer only has one memory module installed on the system board, you can increase your computer memory by installing an additional memory module.

Your computer supports DDR2 memory. For additional information on the type of memory supported by your computer, see [Specifications](#).

## DDR2 Memory Overview

Your computer has a minimum memory configuration of one DDR2 memory module. This memory module must be installed in DIMM1. If two or more DDR2 memory modules are installed, they should be installed in *pairs of matched memory size, speed, and technology*. If the DDR2 memory modules are not installed in matched pairs, the computer will continue to operate, but with a slight reduction in performance. See the label on the module to determine the module's capacity.

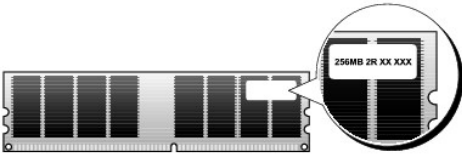

- 📌 **NOTE:** Always install DDR2 memory modules in the order indicated on the system board.
- 🚫 **NOTICE:** Do not install ECC or buffered memory modules. Only unbuffered, non-ECC memory is supported.

The recommended memory configurations are:

- 1 A memory module installed in connector DIMM1
- 1 A pair of matched memory modules installed in connectors DIMM1 and DIMM2
- 1 A pair of matched memory modules installed in connectors DIMM1 and DIMM2 and another matched pair installed in connectors DIMM3 and DIMM4
- 1 If you install mixed pairs of DDR2 533-MHz (PC2-4300) and DDR2 667-MHz (PC2-5400) memory, the modules function at the slower installed speed.

Be sure to populate the memory modules in order starting with DIMM1, the connector closest to the edge of the system board, before you install modules in the other connectors.

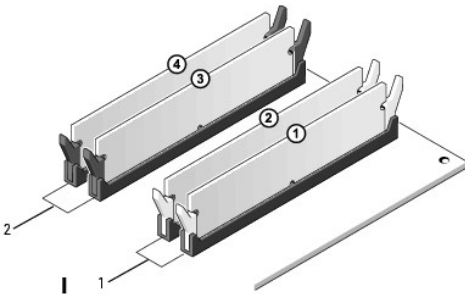

1 Channel A: matched pair of memory modules in connectors DIMM_1 and DIMM_2 (white securing clips)	2 Channel B: matched pair of memory modules in connectors DIMM_3 and DIMM_4 (black securing clips)
--	--

- 📌 **NOTE:** Memory purchased from Dell is covered under your computer warranty.

- ➡ **NOTICE:** If you remove your original memory modules from the computer during a memory upgrade, keep them separate from any new modules that you may have, even if you purchased the new modules from Dell. If possible, *do not* pair an original memory module with a new memory module. Otherwise, your computer may not start properly.

## Installing Memory

- ⚠ **CAUTION:** Before you begin any of the procedures in this section, follow the safety instructions located in the *Product Information Guide*.

- ➡ **NOTICE:** To prevent static damage to components inside your computer, discharge static electricity from your body before you touch any of your computer's electronic components. You can do so by touching an unpainted metal surface on the computer chassis.

1. Follow the procedures in [Before You Begin](#).
2. Press out the securing clip at each end of the memory module connector.

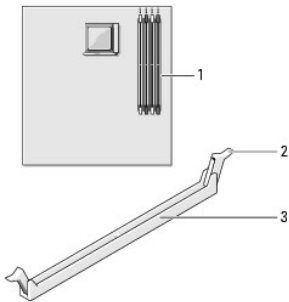

1	memory connector closer to edge of board	2	securing clips (2)	3	connector
---	--	---	--------------------	---	-----------

3. Align the notch on the bottom of the module with the crossbar in the connector.

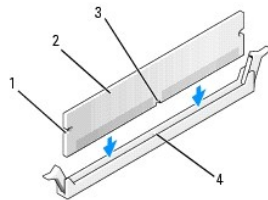

1	cutouts (2)	2	memory module	3	notch
4	crossbar				

- ➡ **NOTICE:** To avoid damage to the memory module, press the module straight down into the connector while you apply equal force to each end of the module.

4. Insert the module into the connector until the module snaps into position.  
If you insert the module correctly, the securing clips snap into the cutouts at each end of the module.

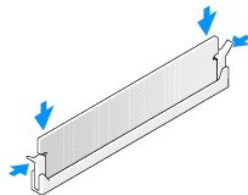

5. Replace the computer cover. See [Replacing the Computer Cover](#).

- ➡ **NOTICE:** To connect a network cable, first plug the cable into the network port or device, and then plug it into the computer.

6. Connect your computer and devices to electrical outlets, and then turn them on.

7. When a message appears stating that memory size has changed, press <F1> to continue.
8. Log on to your computer.
9. Right-click the **My Computer** icon, then click **Properties**.
10. Click the **General** tab.
11. To verify that the memory is installed correctly, check the amount of memory (RAM) listed.

## Removing Memory

**⚠ CAUTION:** Before you begin any of the procedures in this section, follow the safety instructions located in the *Product Information Guide*.

**🔌 NOTICE:** To prevent static damage to components inside your computer, discharge static electricity from your body before you touch any of your computer's electronic components. You can do so by touching an unpainted metal surface on the computer chassis.

1. Follow the procedures in [Before You Begin](#).
2. Press out the securing clip at each end of the memory module connector.
3. Grasp the module and pull up.  
  
If the module is difficult to remove, gently ease the module back and forth to remove it from the connector.
4. Replace the computer cover. See [Replacing the Computer Cover](#).

**🔌 NOTICE:** To connect a network cable, first plug the cable into the network port or device, and then plug it into the computer.

5. Connect your computer and devices to electrical outlets, and then turn them on.

## Cards

**⚠ CAUTION:** Before you begin any of the procedures in this section, follow the safety instructions located in the *Product Information Guide*.

**🔌 NOTICE:** To prevent static damage to components inside your computer, discharge static electricity from your body before you touch any of your computer's electronic components. You can do so by touching an unpainted metal surface on the computer chassis.

Your Dell™ computer provides the following slots for PCI and PCI Express cards:

- 1 One low-profile PCI card slot
- 1 One low-profile PCI Express x1 and x16 card slot

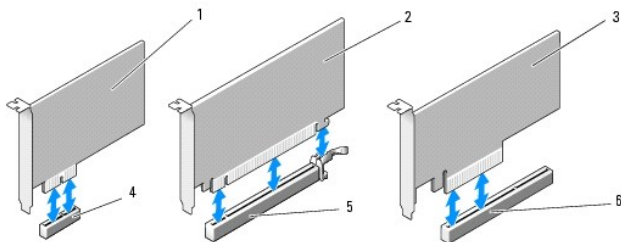

1	PCI Express x1 card	2	PCI Express x16 card	3	PCI
4	PCI Express x1 card slot	5	PCI Express x16 card slot	6	PCI card slot

If you are installing or replacing an expansion card, follow the procedures in the next section. If you are removing and not replacing an expansion card, see [Removing an Expansion Card](#).

If you are replacing a card with a different type of card, remove the current driver for the card from the operating system.

## Installing an Expansion Card

1. Follow the procedures in [Before You Begin](#).
2. Gently push the release tab on the inside of the card retention door to pivot the door open. Because the door is captive, it will remain in the open position.
3. If you are installing a new card, remove the filler bracket to create a card-slot opening, then continue with [step 5](#).

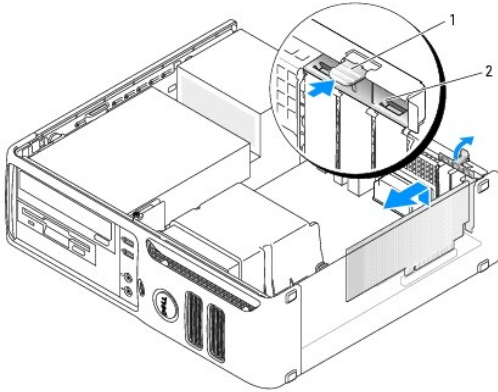

1	release tab	2	card retention door
---	-------------	---	---------------------

4. If you are replacing a card that is already installed in the computer, remove the card.  
If necessary, disconnect any cables connected to the card. Grasp the card by its top corners, and ease it out of its connector.
5. Prepare the card for installation.  
See the documentation that came with the card for information on configuring the card, making internal connections, or otherwise customizing it for your computer.

**⚠ CAUTION:** Some network adapters automatically start the computer when they are connected to a network. To guard against electrical shock, be sure to unplug your computer from its electrical outlet before installing any cards.

6. Place the card in the connector and press down firmly. Ensure that the card is fully seated in the slot.

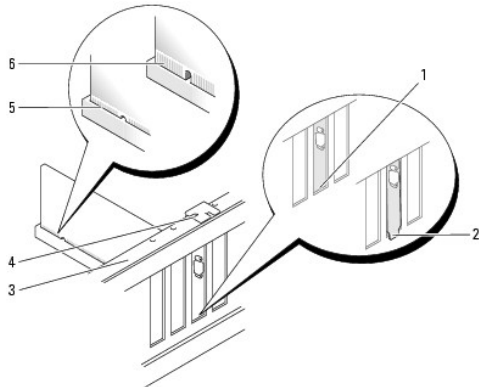

1	bracket within slot	2	bracket caught outside of slot	3	alignment bar
4	alignment guide	5	fully seated card	6	not fully seated card

7. Before you close the card retention door, ensure that:
  - 1 The tops of all cards and filler brackets are flush with the alignment bar.
  - 1 The notch in the top of the card or filler bracket fits around the alignment guide.

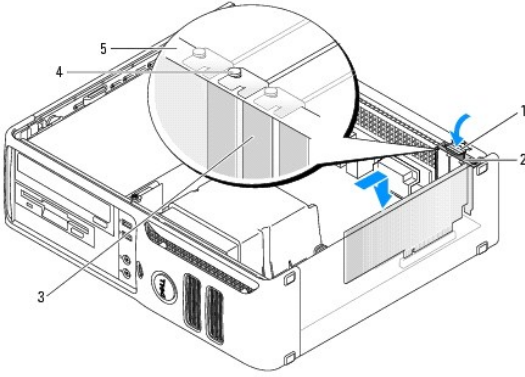

1	release tab	2	card retention door	3	filler bracket
4	alignment guide	5	alignment bar		

8. Close the card retention door by snapping it into place.

➔ **NOTICE:** Do not route card cables over the cards. Cables routed over the cards can prevent the computer cover from closing properly or cause damage to the equipment.

9. Connect any cables that should be attached to the card.

See the documentation for the card for information about the card's cable connections.

➔ **NOTICE:** To connect a network cable, first plug the cable into the network port or device, and then plug it into the computer.

10. Replace the computer cover, reconnect the computer and devices to electrical outlets, and then turn them on.

11. If you installed a sound card:

- a. Enter system setup, select **Integrated Audio** from the **Onboard Devices** group, and change the setting to **Off**. See [System Setup Options](#).
- b. Connect external audio devices to the sound card's connectors. Do not connect external audio devices to the line-in connector on the back panel of the computer. See [Back Panel I/O Connectors](#).

12. If you installed an add-in network adapter and want to disable the integrated network adapter:

- a. Enter system setup, select **Integrated NIC** from the **Onboard Devices** group, and change the setting to **Off**. See [System Setup Options](#).
- b. Connect the network cable to the network adapter card's connectors. Do not connect the network cable to the integrated network connector on the back panel of the computer.

13. Install any drivers required for the card as described in the card documentation.

## Removing an Expansion Card

1. Follow the procedures in [Before You Begin](#).

2. Gently push the release tab on the card retention door from the inside to pivot the door open. Because the door is captive, it will remain in the open position.

3. If necessary, disconnect any cables connected to the card.

4. Remove the card:

If you are removing a PCI or PCI Express x1 card, grasp the card by its top corners and ease it out of its connector. Then go to [step 6](#).

If you are removing a PCI Express x16 card, go to [step 5](#).

5. While pressing the lever, pull the card up and out of the card connector.

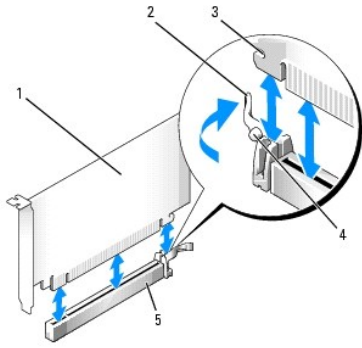

1	PCI Express x16 card	2	lever	3	securing slot
4	securing tab	5	PCI Express x16 card connector		

6. If you are removing the card permanently, install a filler bracket in the empty card-slot opening.

 **NOTE:** Installing filler brackets over empty card-slot openings is necessary to maintain FCC certification of the computer. The brackets also keep dust and dirt out of your computer.

7. Before you close the card retention door, ensure that:

- 1 The tops of all cards and filler brackets are flush with the alignment bar.
- 1 The notch in the top of the card or filler bracket fits around the alignment guide.

8. Close the card retention door by snapping it into place to secure the cards.

 **NOTICE:** To connect a network cable, first plug the cable into the network port or device, and then plug it into the computer.

9. Replace the computer cover, reconnect the computer and devices to electrical outlets, and then turn them on.

10. Remove the card's driver from the operating system.

11. If you removed a sound card:

- a. Enter system setup, select **Integrated Audio** from the **Onboard Devices** group, and change the setting to **On**. See [System Setup Options](#).
- b. Connect external audio devices to the audio connectors on the back panel of the computer. See [Back Panel I/O Connectors](#).

12. If you removed an add-in network connector:

- a. Enter system setup, select **Integrated NIC** from the **Onboard Devices** group, and then change the setting to **On**. See [System Setup Options](#).
- b. Connect the network cable to the integrated connector on the back panel of the computer.

---

## Drives

Your computer supports a combination of these devices:

- 1 One optional floppy drive or Media Card Reader
- 1 One CD or DVD drive
- 1 One serial ATA (SATA) hard drive

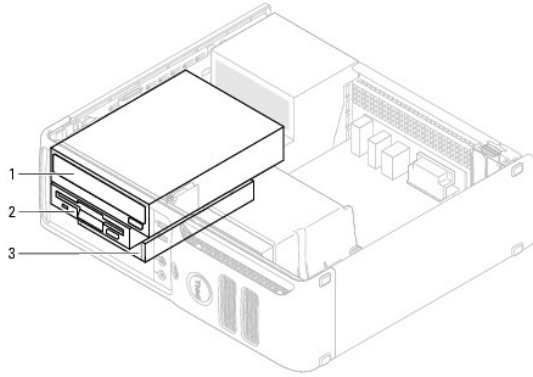

1	DVD drive	2	optional floppy drive or media card reader	3	hard drive
---	-----------	---	--	---	------------

### General Installation Guidelines

Connect the SATA hard drive to the connector labeled "SATA0." Connect the SATA CD or DVD drives to the connector labeled "SATA1" on the system board.

### Connecting Drive Cables

When you install a drive, you connect two cables—a DC power cable and a data cable—to the back of the drive and to the system board.

### Drive Interface Connectors

#### SATA Connector

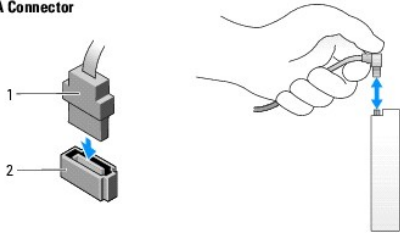

1	interface cable	2	interface connector
---	-----------------	---	---------------------

### Power Cable Connector

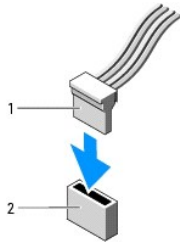

1	power cable	2	power input connector
---	-------------	---	-----------------------

### Connecting and Disconnecting Drive Cables

When removing a SATA data cable, grasp the colored pull tab and pull until the connector detaches. When connecting a SATA data cable, hold the cable by the black connector at each end.

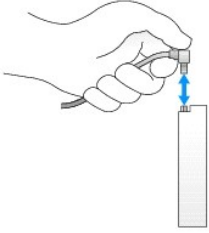

## CD/DVD Drive

**⚠ CAUTION:** Before you begin any of the procedures in this section, follow the safety instructions located in the *Product Information Guide*.

**⚠ CAUTION:** To guard against electrical shock, always unplug your computer from the electrical outlet before removing the cover.

### Removing a CD/DVD Drive

1. Follow the procedures in [Before You Begin](#).

**👉 NOTICE:** Do not pull the drive out of the computer by the drive cables. Doing so may cause damage to the cables and the cable connectors.

2. Pull up on the drive release latch and slide the drive towards the back of the computer. Then, lift up to remove the drive from the computer.

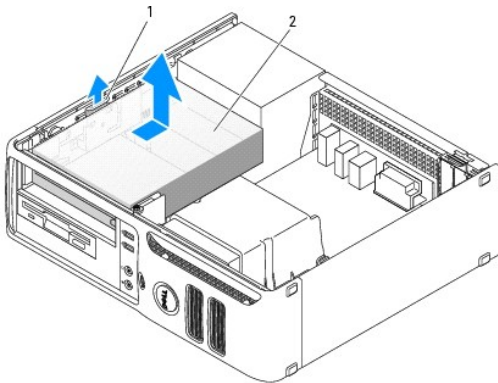

1	drive release latch	2	CD/DVD drive
---	---------------------	---	--------------

3. Disconnect the power and data cables from the back of the drive.

4. Replace the computer cover. See [Replacing the Computer Cover](#).

**👉 NOTICE:** To connect a network cable, first plug the cable into the network port or device, and then plug it into the computer.

5. Connect your computer and devices to electrical outlets, and then turn them on.

### Installing a CD/DVD Drive

1. Follow the procedures in [Before You Begin](#).

2. Unpack the drive and prepare it for installation.

3. If you are installing a new drive:

- a. Press the two snaps on the top of the drive-panel insert and rotate the insert toward the front of the computer. Remove it from the computer.



- b. Remove the three shoulder screws from the drive-panel insert.
4. If you are replacing an existing drive:
  - a. Remove the existing drive.
  - b. Remove the three shoulder screws from the existing drive.
5. Insert the three shoulder screws into the sides of the new drive and tighten them.
6. Connect the power and data cables to the drive.
7. Align the shoulder screws with the screw guides, and slide the drive into the bay until it clicks into place.

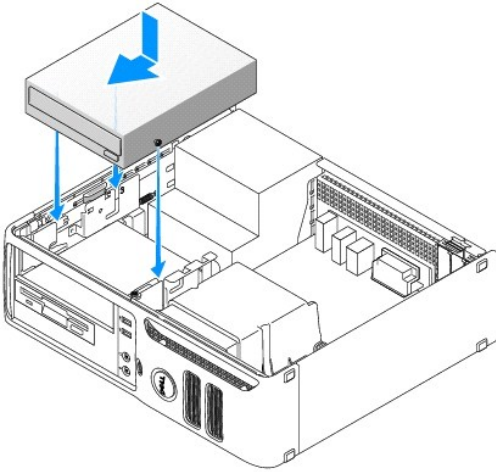

8. Check all cable connections and fold cables out of the way to avoid blocking airflow between the fan and cooling vents.
9. Replace the computer cover. See [Replacing the Computer Cover](#).
- ➡ **NOTICE:** To connect a network cable, first plug the cable into the network port or device, and then plug it into the computer.
10. Connect your computer and devices to electrical outlets, and then turn them on.

---

## Floppy Drive

- ⚠ **CAUTION:** Before you begin any of the procedures in this section, follow the safety instructions located in the *Product Information Guide*.
- ⚠ **CAUTION:** To guard against electrical shock, always unplug your computer from the electrical outlet before removing the cover.

### Removing a Floppy Drive

1. Follow the procedures in [Before You Begin](#).
- 🔧 **NOTE:** It is not necessary to disconnect the cables connected to the CD/DVD drive in the following step, as long as the cables do not obstruct your working area once the drive is set aside.
2. Remove the CD/DVD drive (see [Removing a CD/DVD Drive](#)) and carefully set it aside.
- ➡ **NOTICE:** Do not pull the drive out of the computer by the drive cables. Doing so may cause damage to the cables and cable connectors.
3. Pull up on the drive release latch and slide the floppy drive towards the back of the computer. Then, lift up to remove the drive from the computer.

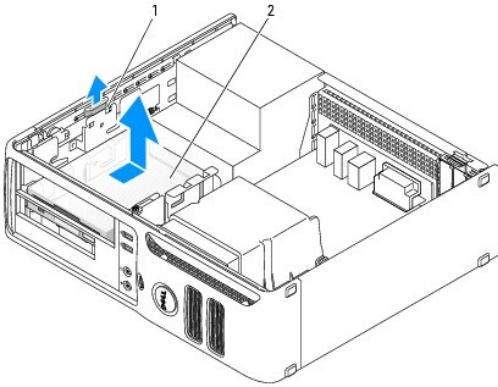

1	drive release latch	2	floppy drive
---	---------------------	---	--------------

4. Disconnect the power and data cables from the back of the floppy drive.
5. Replace the computer cover. See [Replacing the Computer Cover](#).
- ➡ **NOTICE:** To connect a network cable, first plug the cable into the network port or device, and then plug it into the computer.
6. Connect your computer and devices to electrical outlets, and turn them on.

## Installing a Floppy Drive

**⚠ CAUTION:** Before you begin any of the procedures in this section, follow the safety instructions located in the *Product Information Guide*.

➡ **NOTICE:** To prevent static damage to components inside your computer, discharge static electricity from your body before you touch any of your computer's electronic components. You can do so by touching an unpainted metal surface on the computer chassis.

1. Follow the procedures in [Before You Begin](#).
2. Remove the floppy drive and bracket from its packaging.
3. If you are installing a new drive:
  - a. Remove the drive-panel insert that blocks the FlexBay.
  - b. Remove the four shoulder screws from the drive-panel insert.
4. If you are replacing an existing drive:
  - a. Remove the existing drive.
  - b. Remove the four shoulder screws from the existing drive.
5. Insert the four shoulder screws into the sides of the new floppy drive and tighten them.

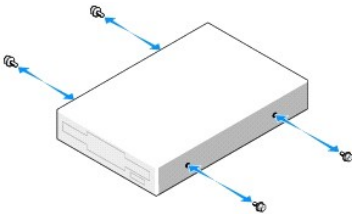

6. Attach the power and data cables to the floppy drive.
7. Locate the correct guidance-slot for the drive (slot 2) and align the shoulder screws with the screw guides.

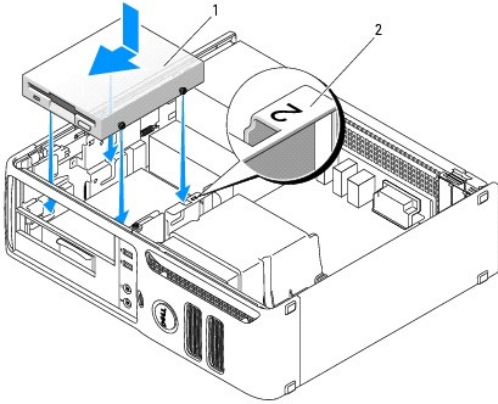

1	floppy drive	2	slot verification number
---	--------------	---	--------------------------

8. Slide the drive into the bay until it clicks into place.
  9. Connect the data cable to the connector labeled "FLOPPY" on the system board.
  10. [Replace the CD/DVD drive.](#)
  11. Check all cable connections, and fold cables out of the way to provide airflow for the fan and cooling vents.
  12. Replace the computer cover. See [Replacing the Computer Cover.](#)
- ➡ **NOTICE:** To connect a network cable, first plug the cable into the network port or device, and then plug it into the computer.
13. Connect your computer and devices to electrical outlets, and then turn them on.

## Media Card Reader

### Removing a Media Card Reader

- ⚠ **CAUTION:** Before you begin any of the procedures in this section, follow the safety instructions located in the *Product Information Guide*.
- ➡ **NOTICE:** To prevent static damage to components inside your computer, discharge static electricity from your body before you touch any of your computer's electronic components. You can do so by touching an unpainted metal surface on the computer chassis.
1. Follow the procedures in [Before You Begin.](#)
- 🔧 **NOTE:** It is not necessary to disconnect the cables connecting the CD/DVD drive in the following step, as long as the cables do not obstruct your working area once the drive is set aside.
2. Remove the CD/DVD drive (see [Removing a CD/DVD Drive](#)) and carefully set it aside.
- ➡ **NOTICE:** Do not pull the drive out of the computer by the drive cables. Doing so may cause damage to the cables and the cable connectors.
3. Disconnect the Media Card Reader USB cable from the USB connector (USB1) on the system board and route the cable through the clip on the shroud.
  4. Pull up on the drive release latch and slide the Media Card Reader towards the back of the computer. Then, lift up to remove it from the computer.

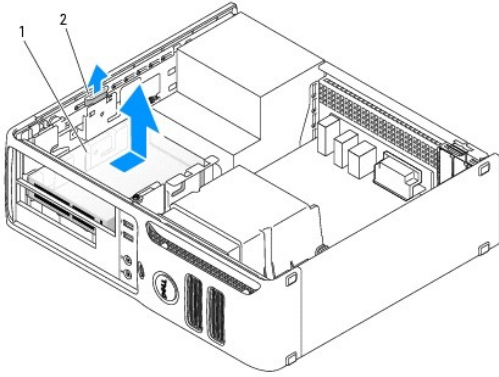

1	Media Card Reader	2	drive release latch		
---	-------------------	---	---------------------	--	--

5. Replace the computer cover. See [Replacing the Computer Cover](#).

➡ **NOTICE:** To connect a network cable, first plug the cable into the network port or device, and then plug it into the computer.

6. Connect your computer and devices to electrical outlets, and then turn them on.

## Installing a Media Card Reader

⚠ **CAUTION:** Before you begin any of the procedures in this section, follow the safety instructions located in the *Product Information Guide*.

➡ **NOTICE:** To prevent static damage to components inside your computer, discharge static electricity from your body before you touch any of your computer's electronic components. You can do so by touching an unpainted metal surface on the computer chassis.

1. Follow the procedures in [Before You Begin](#).
2. Remove the Media Card Reader and bracket from its packaging.
3. If you are installing a new Media Card Reader:
  - a. Remove the drive-panel insert that blocks the FlexBay.
  - b. Remove the four shoulder screws from the drive-panel insert.
4. If you are replacing an existing Media Card Reader:
  - a. Remove the existing Media Card Reader.
  - b. Remove the four shoulder screws from the existing Media Card Reader.
5. Insert four shoulder screws into the sides of the Media Card Reader and tighten them.

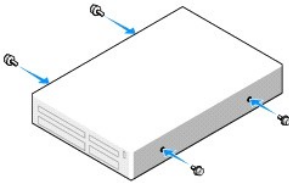

6. Locate the correct guidance-slot for the Media Card Reader (slot 2) and align the shoulder screws with the screw guides.

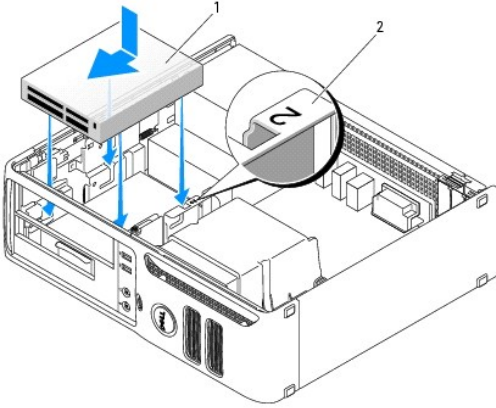

1	Media Card Reader	2	slot verification number
---	-------------------	---	--------------------------

7. Slide the Media Card Reader into the bay until it clicks into place.
  8. Connect the power and data cables to the back of the Media Card Reader.
  9. Connect the data cable to the USB connector on the system board.
  10. Replace the computer cover. See [Replacing the Computer Cover](#).
- ➔ **NOTICE:** To connect a network cable, first plug the cable into the network port or device, and then plug it into the computer.
11. Connect your computer and devices to electrical outlets, and then turn them on.

## Hard Drive

- ⚠ **CAUTION:** Before you begin any of the procedures in this section, follow the safety instructions located in the *Product Information Guide*.
- ⚠ **CAUTION:** To guard against electrical shock, always unplug your computer from the electrical outlet before removing the cover.
- ➔ **NOTICE:** To avoid damage to the drive, do not set it on a hard surface. Instead, set the drive on a surface, such as a foam pad, that will sufficiently cushion it.
- ➔ **NOTICE:** If you are replacing a hard drive that contains data you want to keep, back up your files before you begin this procedure.

Check the documentation for the drive to verify that it is configured for your computer.

## Removing a Hard Drive

1. Follow the procedures in [Before You Begin](#).
- 🔧 **NOTE:** In the following steps it is not necessary to disconnect the cables connecting the CD/DVD or floppy drive or the Media Card Reader, as long as it does not obstruct your working area once it is set aside.
2. Remove the CD/DVD drive (if installed) from the bay and carefully set it aside. See [Removing a CD/DVD Drive](#).
  3. Remove the floppy drive or Media Card Reader (if installed) from the bay and carefully set it aside. See [Removing a Media Card Reader](#) or [Removing a Floppy Drive](#).
  4. Press in on the two plastic securing clips on each side of the drive and slide the drive towards the back of the computer.
- ➔ **NOTICE:** Do not pull the drive out of the computer by the drive cables. Doing so may cause damage to the cables and the cable connectors.
5. Lift the drive out of the computer and disconnect the power and data cables from the drive.

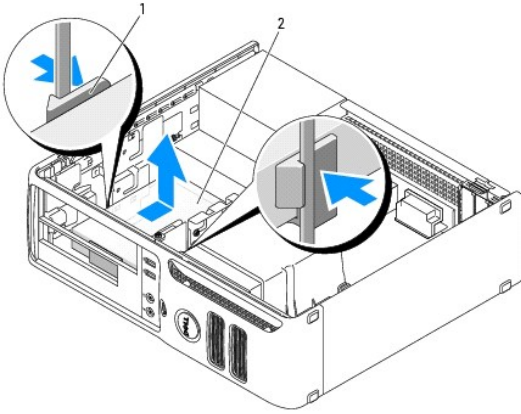

1	securing clips (2)	2	hard drive
---	--------------------	---	------------

### Installing a Hard Drive

1. Check the documentation for the drive to verify that it is configured for your computer.

🚫 **NOTICE:** To avoid damage to the drive, do not set it on a hard surface. Instead, set the drive on a surface, such as a foam pad, that will sufficiently cushion it.

2. Unpack the replacement hard drive, and prepare it for installation.

3. If your replacement hard drive does not have the plastic hard-drive bracket attached, remove the bracket from the existing drive by unsnapping it from the drive.

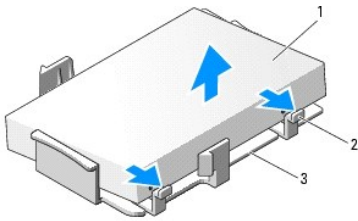

1	hard drive	2	release tabs (2)	3	plastic hard-drive bracket
---	------------	---	------------------	---	----------------------------

4. Attach the bracket to the new drive by aligning the two securing tabs with the mounting holes in the hard drive and then rotating the drive down snapping it onto the bracket.

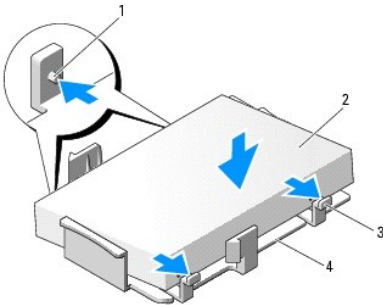

1	securing tabs (2)	2	hard drive	3	release tabs (2)
4	plastic hard-drive bracket				

5. Connect the power and data cables to the drive.

6. Locate the correct guidance-slot for the drive (slot 1) and align the release tabs with the alignment guides.

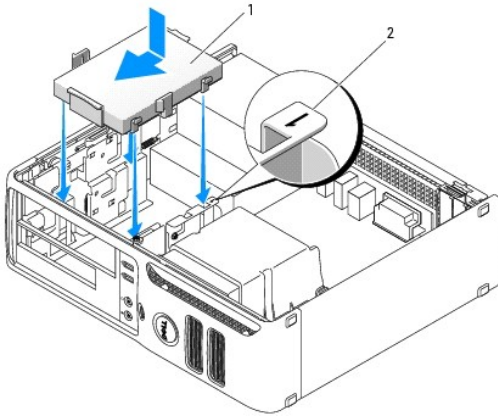

1	hard drive	2	slot verification number
---	------------	---	--------------------------

➡ **NOTICE:** To prevent damaging the hard drive, gently slide the drive into the drive bay. Excessive force could damage the hard drive.

7. Gently slide the drive into the bay until it clicks into place.
8. Replace any drives or readers that you removed.
9. Check all connectors to ensure that they are properly cabled and firmly seated.
10. Replace the computer cover. See [Replacing the Computer Cover](#).

➡ **NOTICE:** To connect a network cable, first plug the cable into the network port or device, and then plug it into the computer.

11. Connect your computer and devices to electrical outlets, and then turn them on.
12. If the drive that you installed is the primary drive, insert bootable media into your boot drive.
13. Enter system setup (see [Entering System Setup](#)) and update the appropriate **Primary Drive** option (**0** or **2**).
14. Exit system setup, and reboot the computer.
15. Partition and logically format your drive before you proceed to the next step.  
For instructions, see the documentation that came with your operating system.
16. Test the hard drive by running the Dell Diagnostics. See [Dell Diagnostics](#).
17. Install your operating system on the hard drive. For instructions, see the documentation that came with your operating system.

## Battery

### Replacing the Battery

⚠ **CAUTION:** Before you begin any of the procedures in this section, follow the safety instructions located in the *Product Information Guide*.

➡ **NOTICE:** To prevent static damage to components inside your computer, discharge static electricity from your body before you touch any of your computer's electronic components. You can do so by touching an unpainted metal surface on the computer chassis.

A coin-cell battery maintains computer configuration, date, and time information. The battery can last several years. If you have to repeatedly reset time and date information after turning on the computer, replace the battery.

⚠ **CAUTION:** A new battery can explode if it is incorrectly installed. Replace the battery only with the same or equivalent type recommended by the manufacturer. Discard used batteries according to the manufacturer's instructions.

To replace the battery:

1. Record all of the settings in system setup (see [System Setup Options](#)) so that you can restore the correct settings in [step 8](#).
2. Follow the procedures in [Before You Begin](#).
3. Locate the battery socket.
4. Remove the battery by carefully pressing the battery release lever away from the battery.

When the battery release lever is properly pressed, the battery should spring out of the socket.

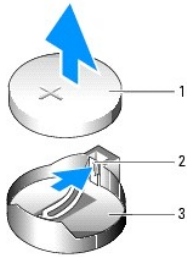

1	battery	2	battery release lever	3	battery socket
---	---------	---	-----------------------	---	----------------

5. Insert the new battery into the socket with the side labeled "+" facing up, and snap the battery into place.
6. Replace the computer cover. See [Replacing the Computer Cover](#).

➡ **NOTICE:** To connect a network cable, first plug the cable into the network port or device, and then plug it into the computer.

7. Connect your computer and devices to electrical outlets, and then turn them on.
8. Enter system setup (see [System Setup](#)) and restore the settings you recorded in [step 1](#).

The system will log a low battery event in the event log. You can clear the log event from System Setup.

9. Properly dispose of the old battery. See the *Product Information Guide* for battery disposal information.

---

## Processor

⚠ **CAUTION:** Before you begin any of the procedures in this section, follow the safety instructions located in the *Product Information Guide*.

### Removing the Processor

1. Follow the procedures in [Before You Begin](#).
2. Loosen the captive screw on each side of the heat sink assembly.

⚠ **CAUTION:** Despite having a plastic shield, the heat sink assembly may be very hot during normal operation. Be sure that it has had sufficient time to cool before you touch it.

➡ **NOTICE:** To avoid damaging the processor or processor socket, slide the heat sink assembly forward and backwards to break the thermal grease seal between the processor and heat sink. If you do not break the seal first, the processor may stick to the heat sink assembly while rotating the assembly upward.

3. Rotate the heat sink assembly upward, and remove the assembly from the computer.

Lay the heat sink assembly down on its top, with the thermal grease facing upward.



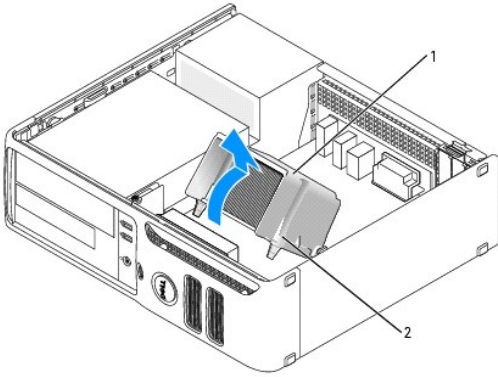

1	heat sink assembly	2	captive screws (2)
---	--------------------	---	--------------------

➡ **NOTICE:** Unless a new heatsink is required for the new processor, reuse the original heat sink assembly when you replace the processor.

4. Pull the release lever straight up until the processor is released.

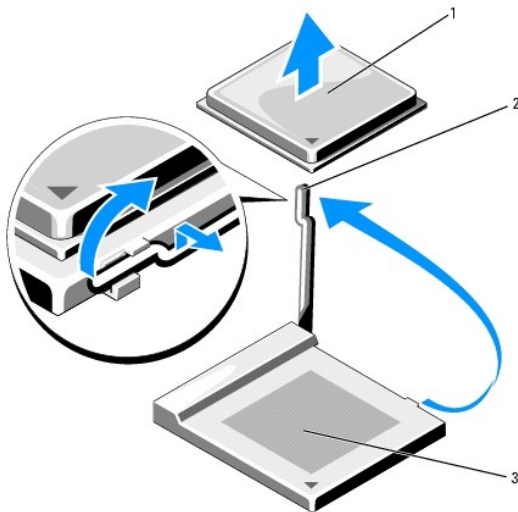

1	processor	2	release lever	3	socket
---	-----------	---	---------------	---	--------

➡ **NOTICE:** Be careful not to bend any of the pins when you remove the processor from the socket. Bending the pins can permanently damage the processor.

5. Remove the processor from the socket.

Leave the release lever extended in the release position so that the socket is ready for the new processor, and go to [Installing the Processor](#).

➡ **NOTICE:** After removing the processor, be careful not to get any thermal grease on the processor pins. Thermal grease on the pins can permanently damage the processor.

## Installing the Processor

➡ **NOTICE:** Ground yourself by touching an unpainted metal surface on the back of the computer.

➡ **NOTICE:** Be careful not to bend any of the pins when you replace the processor. Bending the pins can permanently damage the processor.

1. Follow the procedures in [Before You Begin](#).

➡ **NOTICE:** Be careful not to bend any of the pins when you unpack the processor. Bending the pins can permanently damage the processor.

2. Unpack the new processor, being careful not to bend any of the processor pins.

 **NOTE:** You must position the processor correctly in the socket to avoid permanent damage to the processor and the computer when you turn on the computer.

3. If the release lever on the socket is not fully extended, move it to that position.

4. Align the pin-1 corners of the processor and socket.

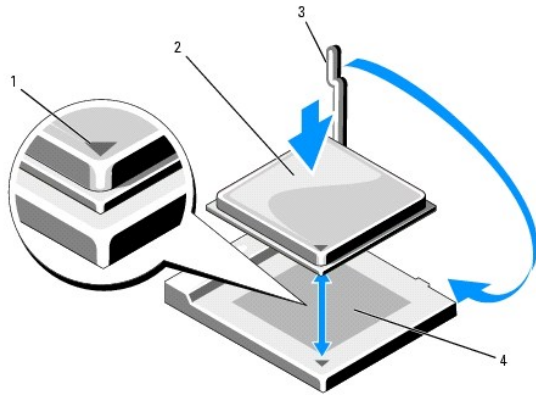

1	pin-1 corner	2	processor	3	release lever
4	socket				

 **NOTE:** To avoid damage, ensure that the processor aligns properly with the socket, and do not use excessive force when you install the processor.

5. Set the processor lightly in the socket and ensure that the processor is positioned correctly.
6. While lightly pressing down on the processor, rotate the release lever back toward the system board until it snaps into place, securing the processor.
7. Clean the thermal grease from the bottom of the heat sink.

 **NOTE:** Ensure that you apply new thermal grease. New thermal grease is critical for ensuring adequate thermal bonding, which is a requirement for optimal processor operation.

8. Apply the new thermal grease to the top of the processor.
9. Install the heat sink assembly:
  - a. Place the heat sink assembly back onto the heat-sink assembly bracket.
  - b. Rotate the heat sink assembly down towards the computer base and ensure that the two captive screws are properly aligned with the holes in the system board.
  - c. Tighten the two captive screws.

 **NOTE:** Ensure that the heat sink assembly is correctly seated and secure.

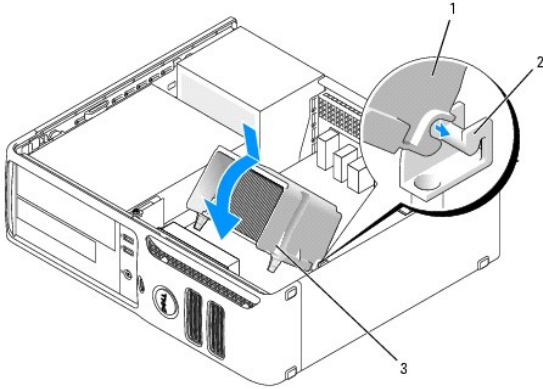

1	heat sink assembly	2	heat-sink assembly bracket	3	captive screws (2)
---	--------------------	---	----------------------------	---	--------------------

10. Replace the computer cover. See [Replacing the Computer Cover](#).

**NOTICE:** To connect a network cable, first plug the cable into the network port or device and then plug it into the computer.

11. Connect your computer and devices to electrical outlets, and turn them on.

---

## Power Supply

### Replacing the Power Supply

**CAUTION:** Before you begin any of the procedures in this section, follow the safety instructions located in the *Product Information Guide*.

**NOTICE:** To prevent static damage to components inside your computer, discharge static electricity from your body before you touch any of your computer's electronic components. You can do so by touching an unpainted metal surface on the computer chassis.

1. Follow the procedures in [Before You Begin](#).
2. Disconnect the DC power cables from the system board and the drives.

Note the routing of the DC power cables underneath the tabs in the computer chassis as you remove them from the system board and drives. You must route these cables properly when you replace them to prevent their being pinched or crimped.

3. Remove the two screws that attach the power supply to the back of the computer chassis.
4. Press the release button located on the floor of the computer chassis.

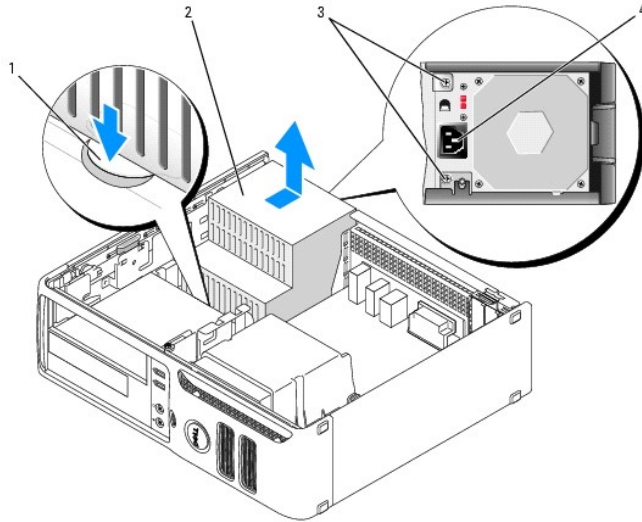

1	release button	2	power supply	3	screws (2)
4	AC power connector				

5. Slide the power supply toward the front of the computer and lift the power supply up and out of the computer.
6. Lower the replacement power supply into the computer.
7. Slide the replacement power supply toward the back of the computer until it snaps into place.
8. Replace the screws that secure the power supply to the back of the computer chassis.
9. Reconnect the DC power cables.
10. Replace the computer cover. See [Replacing the Computer Cover](#).
11. Connect the AC power cable to the AC power connector.

## Front I/O Panel

**⚠ CAUTION:** Before you begin any of the procedures in this section, follow the safety instructions in your *Product Information Guide*.

**⚠ CAUTION:** To guard against electrical shock, always unplug your computer from the electrical outlet before opening the cover.

## Removing the Front I/O Panel

1. Follow the procedures in [Before You Begin](#).
2. Remove the computer cover. See [Removing the Computer Cover](#).
3. Loosen the captive screw on each side of the heat sink assembly. See [Removing the Processor](#).

**⚠ CAUTION:** Despite having a plastic shield, the heat sink assembly may be very hot during normal operation. Be sure that it has had sufficient time to cool before you touch it.

**➡ NOTICE:** To avoid damaging the processor or processor socket, slide the heat sink assembly forward and backwards to break the thermal grease seal between the processor and heat sink. If you do not break the seal first, the processor may stick to the heat sink assembly while rotating the assembly upward.

4. Slide the heat sink assembly forward and backwards to break the thermal grease seal.
5. Rotate the heat sink assembly upward.

6. Disconnect the cable attached to the front I/O panel.
7. Remove the screw that secures the front I/O panel to the chassis.
8. Rotate the I/O panel toward the back of the computer and remove the I/O panel from the computer.

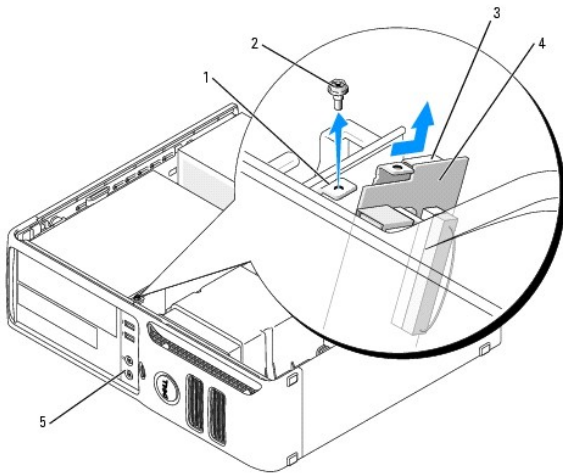

1	securing tab	2	screw	3	I/O panel bracket
4	I/O panel	5	front panel openings		

## Installing the Front I/O Panel

1. Align the I/O panel connectors and lights with the openings in the front panel.
2. Rotate the I/O panel toward the front panel so that the I/O panel bracket aligns with the securing tab.
3. Install the screw that secures the I/O panel to the chassis.
4. Reconnect the cable to the I/O panel.
5. Rotate the heat sink assembly down towards the computer base and ensure that the two captive screws are properly aligned with the holes in the system board.
6. Tighten the two captive screws to secure the heat sink assembly to the system board.
7. Replace the computer cover. See [Replacing the Computer Cover](#).
8. Connect your computer and devices to electrical outlets, and turn them on.

## Fan Assembly

**⚠ CAUTION:** Before you begin any of the procedures in this section, follow the safety instructions in the *Product Information Guide*.

### Removing the Fan Assembly

1. Follow the procedures in [Before You Begin](#).
2. Remove the computer cover. See [Removing the Computer Cover](#).
3. Remove the front I/O panel. See [Removing the Front I/O Panel](#).

**⚠ CAUTION:** The heat-sink assembly can get very hot during normal operation. Be sure that the assembly has had sufficient time to cool before you touch it.

4. Disconnect the fan power cable from the FAN\_CPU1 connector on the system board. See System Board Components.

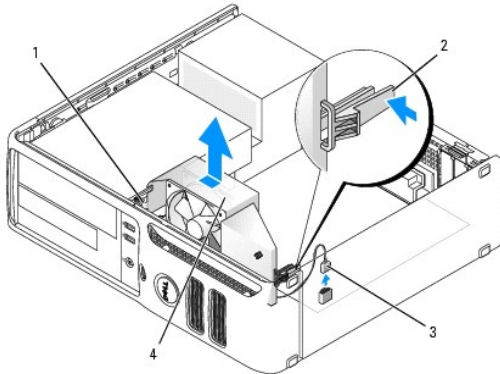

1	fan tabs (2)	2	fan release lever	3	fan cable connector
4	fan assembly				

5. While pressing the fan release lever, rotate the fan assembly toward the back of the computer and up to release the two fan tabs from the vent holes in the chassis.
6. Remove the fan assembly from the computer.

## Installing the Fan Assembly

When reinstalling the fan, ensure that you do not pinch any wires that run near the fan.

**➡ NOTICE:** Ensure that the two fan tabs are fully inserted into the keyhole slots in the chassis so that the fan can slide back fully into position. Ensure that the fan release lever is seated into its slot in the chassis.

1. Lower the fan assembly into the chassis and align the two fan tabs with the vent holes in the chassis.
2. Rotate the fan assembly toward the front of the computer until the fan release lever snaps into place.
3. Connect the fan assembly cable to the FAN\_CPU1 connector on the system board. See [System Board Components](#).
4. Install the front I/O panel. See [Installing the Front I/O Panel](#).
5. Replace the computer cover. See [Replacing the Computer Cover](#).
6. Connect your computer and devices to electrical outlets, and turn them on.

---

## System Board

### Removing the System Board

1. Follow the procedures in [Before You Begin](#).

**➡ NOTICE:** Before touching anything inside your computer, ground yourself by touching an unpainted metal surface, such as the metal at the back of the computer. While you work, periodically touch an unpainted metal surface to dissipate any static electricity that could harm internal components.

2. Remove the computer cover. See [Removing the Computer Cover](#).
3. Remove any components that restrict access to the system board (CD/DVD drive(s), floppy drive, hard drive, power supply).
4. Remove any expansion cards that are installed. See [Removing an Expansion Card](#).

5. Remove the memory. See [Removing Memory](#).

Make a note of where each memory module(s) is installed so that you can reinstall the memory module(s) in the same connector.

6. Remove the processor and heat sink assembly. See [Removing the Processor](#).
7. Remove the fan assemble. See [Removing the Fan Assembly](#).
8. Disconnect all cables from the system board.
9. Remove the eight screws from the system board.

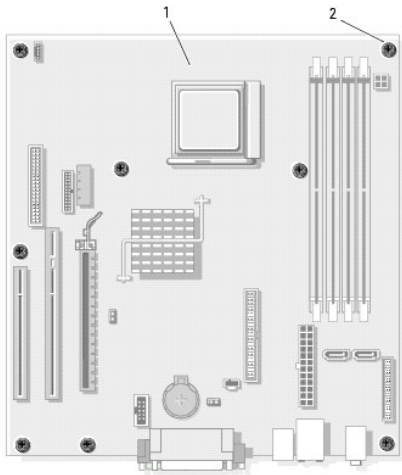

1	system board	2	screws (8)
---	--------------	---	------------

10. Slide the system board assembly toward the front of the computer, and then lift the board up and away.

Place the system board assembly that you just removed next to the replacement system board to ensure it is identical.

## Replacing the System Board

1. Gently align the system board into the chassis and slide it toward the back of the computer.
2. Using the eight screws, secure the system board to the chassis.
3. Replace the fan assembly. See [Installing the Fan Assembly](#).
4. Replace the processor. See [Installing the Processor](#).

5. Replace the memory modules. See [Installing Memory](#).

Ensure that you install the memory modules in the same connectors as noted in [step 5](#) of Removing the System Board.

6. Replace any removed expansion cards. See [Installing an Expansion Card](#).
7. Replace any other components and cables that you removed from the system board.
8. Replace the computer cover. See [Replacing the Computer Cover](#).
9. Connect your computer and devices to electrical outlets, and turn them on.
10. Verify the computer is operational by running the Dell Diagnostics. See [Dell Diagnostics](#).





## Specifications

### Dell™ Dimension™ C521 Service Manual

Microprocessor	
Microprocessor type	AMD™ Athlon™ 64 X2 Dual-Core processor AMD Athlon 64 AMD Sempron™
Internal L2 cache	up to 1 MB per core up to 256 KB for Sempron

Memory	
Type	533-MHz, 667-MHz, 800-MHz z (when available) DDR2 SDRAM
Memory connectors	four
Memory modules supported	256-MB, 512-MB, or 1-GB non-ECC
Minimum memory	256 MB
Maximum memory	4 GB

Computer Information	
Chipset	nVidia GeForce 6150LE
DMA channels	eight
Interrupt levels	24
BIOS chip (NVRAM)	4 Mb
NIC	integrated network interface Capable of 10/100 communication

Video	
Type	nVidia integrated video (DirectX 9.0c Shader Model 3.0 Graphics Processing Unit) or PCI Express x16 graphics card

Audio	
Type	Sigma Tel 9227 CODEC (7.1 Channel Audio)

Controllers	
Drives	two SATA controllers supporting two devices

Expansion Bus	
Bus type	PCI 2.3 PCI Express 1.0A SATA 1.0A and 2.0 USB 2.0
Bus speed	PCI: 133 MB/s PCI Express x16: 80 Gbps bidirectional speed PCI Express x1: 2.5 Gbps SATA: 1.5 Gbps and 3.0 Gbps USB: 480 Mbps high speed, 12 Mbps full speed, 1.2 Mbps low speed
Cards	
PCI	
connectors	one

card size	low profile
connector size	124 pins
connector data width (maximum)	32 bits
PCI Express:	
connectors	one x1 and one x16
power	10 W (x1) and 25 W (x16) maximum
connector size	36 pins (x1) and 164 pins (x16)
connector data width (maximum)	one PCI Express lane (x1) and 16 PCI Express lanes (x16)

<b>Drives</b>	
Externally accessible	one 3.5-inch drive one 5.25-inch drive bay
Available devices	SATA hard drive, CD drive, DVD drive, DVD +/- RW drive, and CD-RW/DVD Combo drive
Internally accessible	one bay for a 1-inch-high hard drive

<b>Connectors</b>	
External connectors:	
Video	15-hole VGA connector
Network adapter	RJ45 connector
USB	two front-panel and four back-panel USB 2.0-compliant connectors
Audio	six connectors for line-in and line-out; two front-panel connectors for headphones and microphone
System board connectors:	
SATA	two 7-pin connectors
Floppy drive	34-pin connector
Fan	5-pin connector
PCI 2.3	124-pin connector
PCIe-x1	36-pin connector
PCIe-x16	164-pin connector
Internal USB	10-pin connector (supports two USB ports)
Speaker	6-pin connector
Memory modules	four 240-pin connectors
Power 12V	4-pin connector
Power	24-pin connector
Battery	2-pin socket

<b>Controls and Lights</b>	
Power control	push button
Power light	green light — Blinking green indicates a sleep mode; solid green indicates a power-on state.  amber light — Blinking amber indicates a problem with an installed device; solid amber indicates an internal power problem (see <a href="#">System Lights</a> ).
Hard-drive access light	green
LAN activity light (front panel)	solid green light indicates network connection
Link integrity light (on integrated network adapter)	green light for 10-Mb operation; orange light for 100-Mb operation
Network activity light (on integrated network adapter)	yellow blinking light
Diagnostic lights	Four lights on the front panel. See <a href="#">Diagnostic Lights</a> .
Standby power light	AUX_PWR on the system board

--	--

<b>Power</b>	
DC power supply:	
Wattage	280 W
Heat dissipation	955.39 BTU/hr maximum  <b>NOTE:</b> Heat dissipation is calculated based upon the power supply wattage rating.
Voltage	manual selection power supply — 90 to 135 V at 50/60 Hz; 180 to 265 V at 50/60 Hz
Backup battery	3-V CR2032 lithium coin cell

<b>Physical</b>	
Height	11.4 cm (4.5 inches)
Width	39.9 cm (15.7 inches)
Depth	35.3 cm (13.9 inches)
Weight	10.4 kg (23 lb)

<b>Environmental</b>	
Temperature:	
Operating	10° to 35°C (50° to 95°F)
Storage	-40° to 65°C (-40° to 149°F)
Relative humidity	20% to 80% (noncondensing)
Maximum vibration:	
Operating	0.25 G at 3 to 200 Hz at 0.5 octave/min
Storage	0.5 G at 3 to 200 Hz at 1 octave/min
Maximum shock:	
Operating	bottom half-sine pulse with a change in velocity of 50.8 cm/sec (20 inches/sec)
Storage	27-G faired square wave with a velocity change of 508 cm/sec (200 inches/sec)
Altitude:	
Operating	-15.2 to 3048 m (-50 to 10,000 ft)
Storage	-15.2 to 10,668 m (-50 to 35,000 ft)

[Back to Contents Page](#)

# System Setup

## Dell™ Dimension™ C521 Service Manual

- [Overview](#)
- [Clearing Forgotten Passwords and CMOS Settings](#)
- [Flashing the BIOS](#)

---

## Overview

### Overview

Use system setup as follows:

- 1 To change the system configuration information after you add, change, or remove any hardware in your computer
- 1 To set or change a user-selectable option such as the user password
- 1 To read the current amount of memory or set the type of hard drive installed

Before you use system setup, it is recommended that you write down the system setup screen information for future reference.

-  **NOTICE:** Unless you are an expert computer user, do not change the settings for this program. Certain changes can make your computer work incorrectly.

### Entering System Setup

1. Turn on (or restart) your computer.
2. When the blue DELL™ logo is displayed, you must watch for the F2 prompt to appear.
3. Once this F2 prompt appears, press <F2> immediately.

-  **NOTE:** The F2 prompt indicates that the keyboard has initialized. This prompt can appear very quickly, so you must watch for it to display, and then press <F2>. If you press <F2> before you are prompted, this keystroke will be lost.

4. If you wait too long and the operating system logo appears, continue to wait until you see the Microsoft® Windows® desktop, then, shut down your computer (see [Turning Off Your Computer](#)) and try again.

### System Setup Screen

The system setup screen displays current or changeable configuration information for your computer. Information on the screen is divided into four areas: the menu at the top, the main window, the Item Help field on the right, and key functions listed on the bottom.

**Options List** — This field appears on the left side of the system setup window. The field is a scrollable list containing features that define the configuration of your computer, including installed hardware, power conservation, and security features.

Scroll up and down the list by using the up- and down- arrow keys. As an option is highlighted, the **Option Field** displays more information about that option and the option's current and available settings.

**Option Field** — This field contains information about each option. In this field you can view your current settings and make changes to your settings.

Use the right- and left-arrow keys to highlight an option. Press <Enter> to make that selection active.

**Key Functions** — This field appears below the **Option Field**

and lists keys and their functions within the active system setup field.

## System Setup Options

 **NOTE:** Depending on your computer and installed devices, the items listed in this section may not appear, or may not appear exactly as listed.

System	
System Info	Lists the computer name, <b>BIOS Version</b> , <b>Service Tag</b> , <b>Express Service Code</b> , (if applicable), and the <b>Asset Tag</b> . None of these fields can be modified.
Processor Info	Identifies the CPU type, processor clock speed, bus speed, L2 cache size, and processor ID. States whether the processor supports 64-bit technology.
Memory Info	Lists the type, size, speed, and channel mode (dual or single) of installed memory.
PCI Info	Identifies any installed PCI or PCI Express cards.
Date/Time	Displays current date and time settings.
Boot Sequence	The computer attempts to boot from the sequence of devices specified in this list.
HDD Boot Sequence	Lists the order that the BIOS will search the available hard drives in the system.

Drives	
Diskette Drive  ( <b>Internal</b> default)	This option enables or disables the floppy drive. The options are <b>Off</b> , <b>USB</b> , <b>Internal</b> , and <b>Read Only</b> .  <b>NOTE:</b> If <b>USB</b> is selected, ensure that USB Controller setup option under Onboard Devices is set to <b>On</b> .
Drive 0: (SATA-0)  ( <b>On</b> default)	Identifies and enables and disables the drives attached to the SATA connectors on the system board and lists the capacities for the hard drives.
Drive 1: (SATA-1)  ( <b>On</b> default)	Identifies and enables and disables the drives attached to the SATA connectors on the system board and lists the capacities for the hard drives.
SATA Operation  ( <b>Off</b> default)	The field configures the operating mode of the integrated hard drive controller.  <ul style="list-style-type: none"> <li>1 <b>RAID Off</b> — No RAID support</li> <li>1 <b>RAID On</b> — SATA is configured for RAID on every boot.</li> </ul>
SMART Reporting  ( <b>Off</b> default)	This setting determines whether integrated drive errors are reported or not during system startup.

Onboard Devices	
Integrated NIC  ( <b>On</b> default)	Enables or disables the integrated NIC controller. Settings are <b>Off</b> , <b>On</b> , <b>On w/ PXE</b> , or <b>On w/RPL</b> . When the <b>On w/ PXE</b> or the <b>On w/RPL</b> setting is active, if a boot routine is not available from the network server, the computer attempts to boot from the next device in the boot sequence list.
Integrated Audio  ( <b>On</b> default)	Enables or disables the onboard audio controller.
USB Controller  ( <b>On</b> default)	Enables or disables the internal USB controller. <b>No Boot</b> enables the controller but disables the ability to boot from a USB device.  <b>NOTE:</b> Operating systems with USB support will recognize USB floppy drives regardless of the <b>No Boot</b> setting.
Rear Dual USB0  ( <b>On</b> default)	Enables or disables the indicated group of USB ports on the back of the computer.
Rear Dual USB1  ( <b>On</b> default)	Enables or disables the indicated group of USB ports on the back of the computer.
Front USB  ( <b>On</b> default)	Enables or disables the indicated group of USB ports on the front of the computer.

Video	
Primary Video	This setting specifies which video controller is primary when there is two video controllers available. This selection only matters when if there are two video controllers present. When Auto is selected, the add-in video controller will be used.

(Auto default)	
Video Memory Size  (64MB default)	<b>NOTE:</b> A PCI Express graphics card will override the integrated video controller.  This setting configures the amount of system memory that is reserved for the integrated video controller. The settings are Auto, 16MB, 32MB, 64MB, 128MB, or Off.

<b>Performance</b>	
HDD Acoustic Mode (Bypass default)	<ul style="list-style-type: none"> <li>1 <b>Bypass</b> — Your computer does not test or change the current acoustics mode setting.</li> <li>1 <b>Quiet</b> — The hard drive operates at its most quiet setting.</li> <li>1 <b>Suggested</b> — The hard drive operates at the level suggested by the drive manufacturer.</li> <li>1 <b>Performance</b> — The hard drive operates at its maximum speed.</li> </ul> <p><b>NOTE:</b> Switching to performance mode may cause the drive to be noisier, but its performance is not affected. Changing the acoustics setting does not alter your hard-drive image.</p>

<b>Security</b>	
Unlock Setup	When an administrator password is being used, allows the user access to modify system setup settings. Enter the administrator password at the prompt to unlock system setup. If the correct password is not entered here, the user can view but not modify system setup fields.
Admin Password  (Not Set default)	Displays the current status of your system setup program's password security feature and allows you to verify and assign a new admin password.
System Password  (Not Set default)	Displays the current status of the system's password security feature and allows a new system password to be assigned and verified.
Password Changes  (Unlocked default)	Determines the interaction between the <b>System</b> password and the <b>Admin</b> password. <b>Locked</b> prevents a user without a valid <b>Admin</b> password from being able to modify the <b>System</b> password. <b>Unlocked</b> allows a user with a valid <b>System</b> password to modify the system password.
No-Execute  (On default)	Enables or disables Execute Disable memory protection technology.

<b>Power Management</b>	
AC Recovery  (Off default)	Determines how the system responds when AC power is re-applied after a power loss. <b>Off</b> commands the system to stay off when the power is re-applied. You must press the front-panel power button before the system turns on. <b>On</b> commands the system to turn on when the power is re-applied. <b>Last</b> commands the system to return to the last power state the system was in just before it was turned off.
Auto Power On  (Off default)	Sets the computer to automatically turn on. <b>Off</b> disables this feature. <b>Everyday</b> turns the computer on every day at the time set in <b>Auto Power Time</b> . <b>Weekdays</b> turns the computer on every day from Monday through Friday at the time set in <b>Auto Power Time</b> .  <b>NOTE:</b> This feature does not work if you turn off your computer using the switch on a power strip or surge protector.
Auto Power Time	Sets time to automatically turn on the computer.  Time is kept in the standard 12-hour format ( <i>hours:minutes</i> ). Change the startup time by pressing the right- or left-arrow key to increase or decrease the numbers, or type numbers in both the date and time fields.
Low Power Mode  (Off default)	When <b>Low Power Mode</b> is selected, remote wakeup events will no longer power up the computer from <b>Hibernate</b> or <b>Off</b> via the onboard network controller.
Cool and Quiet  (On default)	This option enables or disables the Cool 'n' Quiet™ technology for all supported processors.
Suspend Mode  (S3 default)	Sets the computer's suspend mode. The options are <b>S1</b> , a suspend state in which the computer is running in a low-power mode, and <b>S3</b> , a suspend state in which the power is reduced or turned off for many components, however, system memory remains active.

<b>Maintenance</b>	
Service Tag	Displays the service tag for your computer.

Load Defaults	Restores system setup options to their factory defaults.
Event Log	Allows you to view the <b>Event Log</b> . Entries are marked <b>R</b> for <b>Read</b> and <b>U</b> for <b>Unread</b> . <b>Mark All Entries Read</b> puts an <b>R</b> to the left of all the entries. <b>Clear Log</b> clears the <b>Event Log</b> .

POST Behavior	
Fast Boot (On default)	When enabled, this feature reduces computer startup time by bypassing some compatibility steps. <b>Off</b> does not skip any steps during computer startup. <b>On</b> starts the system more quickly.
Numlock Key (On default)	Determines the functionality of the numeric keys on the right side of your keyboard. <b>Off</b> commands the right keypad keys to function as arrows. <b>On</b> commands the right keypad keys to function as numbers.
POST Hotkeys (Setup & Boot Menu default)	Determines whether the sign-on screen displays a message stating the keystroke sequence that is required to enter the <b>Setup</b> program or the <b>Quickboot</b> feature. <b>Setup &amp; Boot Menu</b> displays both messages (F2=Setup and F12=Boot Menu). <b>Setup</b> displays the setup message only (F2=Setup). <b>Boot Menu</b> displays the <b>Quickboot</b> message only (F12=Boot Menu). <b>None</b> displays no message.
Keyboard Errors (Report default)	When set to <b>Report</b> (enabled) and an error is detected during POST, the BIOS will display the error message and prompt you to press <F1> to continue or press <F2> to enter system setup.  When set to <b>Do Not Report</b> (disabled) and an error is detected during POST, the BIOS will display the error message and continue booting the system.

## Boot Menu

This feature allows you to change the boot sequence for devices.

### Option Settings

1. **Bootable Hard Drive** — The computer attempts to boot from the primary hard drive. If no operating system is on the drive, the computer generates an error message.
1. **Onboard Floppy Drive** — The computer attempts to boot from the floppy drive. If the floppy disk in the drive is not bootable, if no floppy disk is in the drive, or if there is no floppy drive installed in the computer, the computer generates an error message.
1. **Onboard CD-ROM Drive** — The computer attempts to boot from the CD drive. If no CD is in the drive, or if the CD has no operating system, the computer generates an error message.
1. **Integrated NIC** — The computer attempts to boot using the integrated NIC. If integrated NIC is not connected, the computer generates an error message.
1. **USB-Device, USB-Floppy, USB-CDROM** — Attach the device to a USB port and restart the computer before selecting the option from the Boot Menu. The computer will attempt to boot from the appropriate USB device. If no operating system is on the appropriate drive or disk, the computer will generate an error message.

 **NOTE:** To boot to a USB device, the device must be bootable. To ensure that a device is bootable, check the device documentation.

#### Changing Boot Sequence for the Current Boot

You can use this feature, for example, to restart your computer to a USB device, such as a floppy drive, memory key, or CD-RW drive.

 **NOTE:** If you are booting to a USB floppy drive, you must first set **Diskette Interface** to **Disabled** in system setup (see [System Setup Options](#)).

1. If you are booting to a USB device, connect the USB device to a USB connector. See [Front View](#).
2. Turn on (or restart) your computer.
3. When F2 = Setup, F12 = Boot Menu appears in the upper-right corner of the screen, press <F12>.

If you wait too long and the operating system logo appears, continue to wait until you see the Microsoft Windows desktop, then shut down your computer. See [Turning Off Your Computer](#) and try again.

4. Press <F1> to continue.

The **Boot Menu** appears, listing all available boot devices.

5. Use the arrow keys to select the appropriate device (for the current boot only).

 **NOTE:** To boot to a USB device, the device must be bootable. To ensure that a device is bootable, check the device documentation.

### Changing Boot Sequence for Future Boots

1. Enter system setup, select **Boot Sequence** from the **System** group. See [System Setup Options](#).
  2. Press <Enter> to access the menu.  
 **NOTE:** Write down your current boot sequence in case you want to restore it.
  3. Press the up- and down-arrow keys to highlight the appropriate **Boot Sequence** option.
  4. Press the **U** or **D** key to move the option **up** or **down** in the boot sequence.
  5. Press <Enter> to **Save** the changes or <Esc> to **Cancel**.
- 



## Clearing Forgotten Passwords and CMOS Settings

 **CAUTION:** Before you begin any of the procedures in this section, follow the safety instructions located in the *Product Information Guide*.

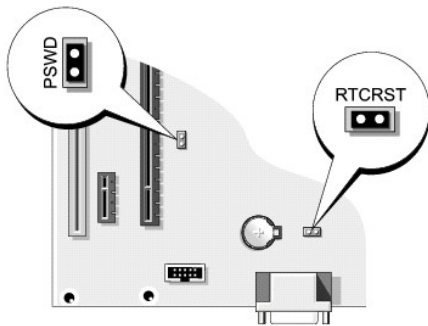
### Jumper Locations



### Clearing Password Settings

1. Follow the procedures in [Before You Begin](#).
2. Locate the 2-pin password jumper (PSWD) on the system board (see [Jumper Locations](#)), and attach the jumper plug to pins 1 and 2 to clear the password.  
 **NOTE:** When you receive your computer, the jumper plug is attached to pin 1.
3. Replace the computer cover. See [Replacing the Computer Cover](#).
4. Connect your computer and monitor to electrical outlets, and then turn them on.
5. After the Microsoft® Windows® desktop appears on your computer, shut down the computer. See [Turning Off Your Computer](#).
6. Turn off the monitor and disconnect it from the electrical outlet.
7. Disconnect the computer power cable from the electrical outlet, then press the power button to ground the system board.
8. Remove the computer cover. See [Replacing the Computer Cover](#).
9. Locate the 2-pin password jumper (PSWD) on the system board and attach the jumper to pin 1 to reenble the password feature.
10. Replace the computer cover. See [Replacing the Computer Cover](#).
-  **NOTICE:** To connect a network cable, first plug the cable into the network port or device, and then plug it into the computer.
11. Connect your computer and devices to electrical outlets, and then turn them on.



## Clearing CMOS Settings

 **CAUTION:** Before you begin any of the procedures in this section, follow the safety instructions located in the *Product Information Guide*.

1. Follow the procedures in [Before You Begin](#).
2. Reset the current CMOS settings:
  - a. Locate the 2-pin CMOS jumper (RTCRST) on the system board. See [Jumper Locations](#).
  - b. Remove the jumper plug from pin 1.
  - c. Place the jumper plug on pins 1 and 2 and wait approximately five seconds.
  - d. Replace the jumper plug on pin 1.
3. Replace the computer cover. See [Replacing the Computer Cover](#).

 **NOTICE:** To connect a network cable, first plug the cable into the network port or device, and then plug it into the computer.

4. Connect your computer and devices to electrical outlets, and then turn them on.
- 

## Flashing the BIOS

The BIOS may require a new flash when an update is available or when replacing the system board.

1. Turn on the computer.
  2. Locate the BIOS update file for your computer at [support.dell.com](http://support.dell.com).
  3. Click **Download Now** to download the file.
  4. If the **Export Compliance Disclaimer window** appears, click **Yes, I Accept the Agreement**.  
The **File Download window** appears.
  5. Click **Save this program to disk** and then click **OK**.  
The **Save In window** appears.
  6. Click the down arrow to view the **Save In** menu, select **Desktop**, and then click **Save**.  
The file downloads to your desktop.
  7. Click Close when the **Download Complete** window appears.  
The file icon appears on your desktop and is titled the same as the download BIOS update file.
  8. Double-click the file icon on the desktop and follow the on-screen instructions.
- 

[Back to Contents Page](#)

## Technical Overview

### Dell™ Dimension™ C521 Service Manual

- [Inside View of Your Computer](#)
- [System Board Components](#)
- [Power Supply DC Connector Pin Assignments](#)

---

## Inside View of Your Computer

**⚠ CAUTION:** Before you begin any of the procedures in this section, follow the safety instructions in the *Product Information Guide*.

**⚠ CAUTION:** To guard against electrical shock, always unplug your computer from the electrical outlet before opening the cover.

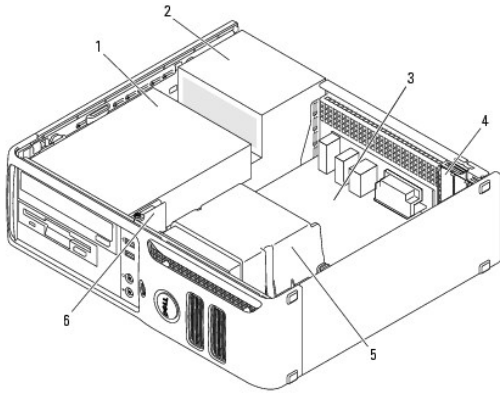

1	drives bay (CD/DVD, floppy, media card reader, and hard drive)	2	power supply	3	system board
4	card slots	5	heat sink assembly	6	front I/O panel

---

## System Board Components

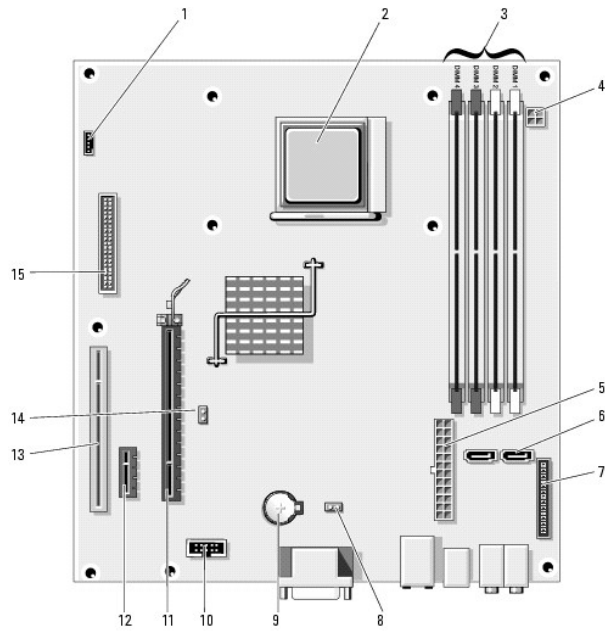

1	fan connector (FAN_CPU1)	2	processor socket (CPU)	3	memory module connectors (DIMM_1, DIMM_2, DIMM_3, DIMM_4)
4	power connector (PW_12V_A1)	5	power connector (POWER1)	6	SATA drive connectors (SATA0, SATA1)
7	front-panel connector (FRONTPANEL)	8	CMOS reset (RTCST)	9	battery socket (BT1)
10	internal USB (USB1)	11	PCI Express x16 connector (SLOT1)	12	PCI Express x1 connector (SLOT2)
13	PCI connector (SLOT3)	14	password jumper (PSWD)	15	floppy drive connector (FLOPPY1)

## Jumper Settings

The jumper locations are shown below.

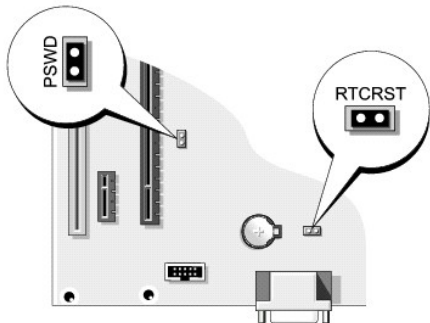

Jumper	Setting	Description
PSWD		Password features are enabled (default setting).
		Password features are disabled.
RTCST		The real-time clock has not been reset.

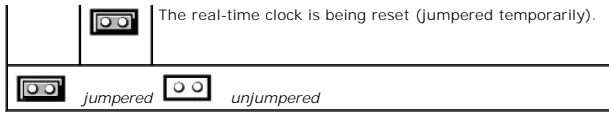

## Power Supply DC Connector Pin Assignments

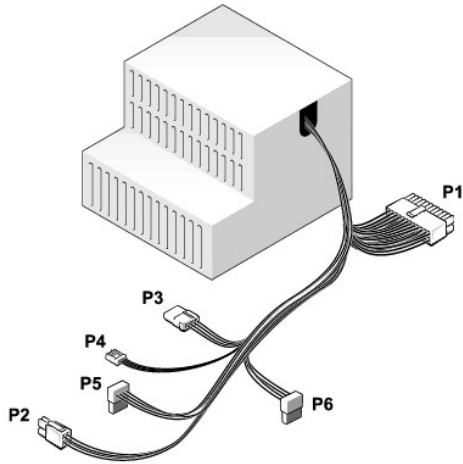

### DC Power Connector P1

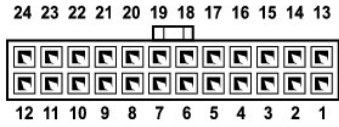

Pin Number	Signal name	18-AWG Wire
1	+3.3 VDC	Orange
2	+3.3 VDC	Orange
3	GND	Black
4	VCC (+5 V)	Red
5	GND	Black
6	VCC (+5 V)	Red
7	GND	Black
8	PS_PWRGOOD	Gray
9	P5AUX	Purple
10	V_12PO_DIG	White
11	V_12PO_DIG	White
12	+3.3 V	Orange
13	+3.3 V	Orange
14	-12 V*	Blue
15	GND	Black
16	PWR_PS_ON	Green
17	GND	Black
18	GND	Black
19	GND	Black
20	NC	N/C
21	VCC (+5V)	Red
22	VCC (+5V)	Red

23	VCC (+5V)	Red
24	GND	Black

\*Use 22-AWG wire instead of 18-AWG wire.

### DC Power Connector P2



Pin Number	Signal Name	18-AWG Wire
1	COM	Black
2	COM	Black
3	+12 VDC	Yellow
4	+12 VDC	Yellow

### DC Power Connector P3

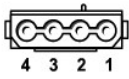

Pin Number	Signal name	18-AWG Wire
1	+12VDC	Yellow
2	COM	Black
3	COM	Black
4	+5 VDC	Red

### DC Power Connector P4

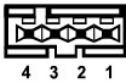

Pin Number	Signal Name	22-AWG Wire
1	+5 VCD	Red
2	COM	Black
3	COM	Black
4	+12 VDC	Yellow

### DC Power Connector P5 and P6



Pin Number	Signal name	18-AWG Wire
1	+3.3 VDC	Orange
2	COM	Black

3	+5 VDC	Red
4	COM	Black
5	+12 VDC	Yellow

---



[Back to Contents Page](#)

[Back to Contents Page](#)

## Dell™ Dimension™ C521 Service Manual

---

### Notes, Notices, and Cautions

-  **NOTE:** A NOTE indicates important information that helps you make better use of your computer.
  -  **NOTICE:** A NOTICE indicates either potential damage to hardware or loss of data and tells you how to avoid the problem.
  -  **CAUTION:** A CAUTION indicates a potential for property damage, personal injury, or death.
- 
- 

Information in this document is subject to change without notice.  
© 2006 Dell Inc. All rights reserved.

Reproduction in any manner whatsoever without the written permission of Dell Inc. is strictly forbidden.

Trademarks used in this text: *Dell*, the *DELL* logo, and *Dimension* are trademarks of Dell Inc.; *AMD*, *AMD Athlon*, and combinations thereof, *Sempron*, and *Cool 'n' Quiet* are trademarks of Advanced Micro Devices, Inc; *Microsoft* and *Windows* are registered trademarks of Microsoft Corporation.

Other trademarks and trade names may be used in this document to refer to either the entities claiming the marks and names or their products. Dell Inc. disclaims any proprietary interest in trademarks and trade names other than its own.

September 2006 Rev. A00

---

[Back to Contents Page](#)

## Troubleshooting

### Dell™ Dimension™ C521 Service Manual

- [Dell Diagnostics](#)
- [System Lights](#)
- [Diagnostic Lights](#)
- [Beep Codes](#)

---

## Dell Diagnostics

 **CAUTION:** Before you begin any of the procedures in this section, follow the safety instructions in the *Product Information Guide*.

### When to Use the Dell Diagnostics

If you experience a problem with your computer, perform the checks in this section and run the Dell Diagnostics before you contact Dell for technical assistance.

 **NOTICE:** The Dell Diagnostics works only on Dell™ computers.

1. Turn on (or restart) your computer.
2. When the DELL™ logo appears, press <F12> immediately.  
  
If you wait too long and the operating system logo appears, continue to wait until you see the Microsoft® Windows® desktop. Then shut down your computer and try again.
3. When the boot device list appears, highlight **Boot to Utility Partition** and press <Enter>.
4. When the Dell Diagnostics **Main Menu** appears, select the test you want to run (see [Dell Diagnostics Main Menu](#)).

### Dell Diagnostics Main Menu

1. After the Dell Diagnostics loads and the **Main Menu** screen appears, click the button for the option you want.

Option	Function
Express Test	Performs a quick test of devices. This test typically takes 10 to 20 minutes and requires no interaction on your part. Run <b>Express Test</b> first to increase the possibility of tracing the problem quickly.
Extended Test	Performs a thorough check of devices. This test typically takes an hour or more and requires you to answer questions periodically.
Custom Test	Tests a specific device. You can customize the tests you want to run.
Symptom Tree	Lists the most common symptoms encountered and allows you to select a test based on the symptom of the problem you are having.

2. If a problem is encountered during a test, a message appears with an error code and a description of the problem. Write down the error code and problem description and follow the instructions on the screen.

If you cannot resolve the error condition, contact Dell. For information about contacting Dell, see your *Owner's Manual*.

 **NOTE:** The Service Tag for your computer is located at the top of each test screen. If you contact Dell, technical support will ask for your Service Tag.

3. If you run a test from the **Custom Test** or **Symptom Tree** option, click the applicable tab described in the following table for more information.

Tab	Function
Results	Displays the results of the test and any error conditions encountered.
Errors	Displays error conditions encountered, error codes, and the problem description.
Help	Describes the test and may indicate requirements for running the test.



Configuration	Displays your hardware configuration for the selected device.  The Dell Diagnostics obtains configuration information for all devices from system setup, memory, and various internal tests, and it displays the information in the device list in the left pane of the screen. The device list may not display the names of all the components installed on your computer or all devices attached to your computer.
Parameters	Allows you to customize the test by changing the test settings.

Close the test screen to return to the **Main Menu** screen. To exit the Dell Diagnostics and restart the computer, close the **Main Menu** screen.

## System Lights

Your power button light and hard-drive activity light may indicate a computer problem.

Power Light	Problem Description	Suggested Resolution
Off	The computer is in a normal "off" condition or in a power-conserving mode.	None. Press the power button to wake the computer or to turn the computer on.
Solid green	The computer has successfully booted and is operating normally.	None.
Blinking green	The computer is in a Windows standby power-saving state (S1 or S3).	None. Move the mouse, press the spacebar, or use another device that has been configured as a wake-up device to wake the computer.
Solid Amber	A pre-POST failure has occurred. The system has received a Power Good signal from the power supply.	See <a href="#">Diagnostic Lights</a> for more information.  If this does not resolve your problem, contact Dell. For information about contacting Dell, see your <i>Owner's Manual</i> .
Blinking Amber	A possible power supply failure has occurred. The system has not received a Power Good signal from the power supply.	Plug the computer into a working electrical outlet.

Hard-Drive Activity Light	Problem Description	Suggested Resolution
Solid green	The hard-drive activity light is on when the computer reads data from or writes data to the hard drive. The light might also be on when a device such as a CD player is operating.	No corrective action is required.

## Diagnostic Lights

**⚠ CAUTION:** Before you begin any of the procedures in this section, follow the safety instructions in the *Product Information Guide*.

To help you troubleshoot a problem, your computer has four lights labeled "1," "2," "3," and "4" on the front panel. When the computer starts normally, the lights flash. After the computer starts, all four lights display solid green. If the computer malfunctions, the color and sequence of the lights identify the problem.

Light Pattern	Problem Description	Suggested Resolution
①②③④	The computer is in a normal condition or a possible pre-POST failure has occurred.	See <a href="#">System Lights</a> .
①②③④	The computer is in recovery mode.	None.
①②③④	A possible processor failure was detected.	Contact Dell. For information about contacting Dell, see your <i>Owner's Manual</i> .
①②③④	Memory modules are detected, but a memory failure has occurred.	<ol style="list-style-type: none"> <li>If you have two or more memory modules installed, remove the modules, reinstall one module (see <a href="#">Memory</a>), and then restart the computer. If the computer starts normally, reinstall an additional module. Continue until you have identified a faulty module or reinstalled all modules without error.</li> <li>If available, install properly working memory of the same type into your computer (see <a href="#">Memory</a>).</li> <li>If the problem persists, contact Dell. For information about contacting Dell, see your <i>Owner's Manual</i>.</li> </ol>
①②③④	A possible graphics failure has occurred.	If the problem persists, contact Dell. For information about contacting Dell, see your <i>Owner's Manual</i> .
①②③④	A possible floppy drive or hard drive failure has occurred.	Reseat all power and data cables and restart the computer.

①②③④	A possible USB failure has occurred.	Reinstall all USB devices, check cable connections, and then restart the computer.
①②③④	No memory modules are detected.	<ol style="list-style-type: none"> <li>If you have two or more memory modules installed, remove the modules, reinstall one module (see <a href="#">Memory</a>), and then restart the computer. If the computer starts normally, reinstall an additional module. Continue until you have identified a faulty module or reinstalled all modules without error.</li> <li>If available, install properly working memory of the same type into your computer (see <a href="#">Memory</a>).</li> <li>If the problem persists, contact Dell. For information about contacting Dell, see your <i>Owner's Manual</i>.</li> </ol>
①②③④	Memory modules are detected, but a memory configuration or compatibility error exists.	<ol style="list-style-type: none"> <li>Ensure that no special memory module/memory connector placement requirements exist (see <a href="#">Memory</a>).</li> <li>Verify that the memory modules that you are installing are compatible with your computer (see <a href="#">Memory</a>).</li> <li>If the problem persists, contact Dell. For information about contacting Dell, see your <i>Owner's Manual</i>.</li> </ol>
①②③④	A possible expansion card failure has occurred.	<ol style="list-style-type: none"> <li>Determine whether a conflict exists by removing a card and restarting the computer (see <a href="#">Cards</a>).</li> <li>If the problem persists, reinstall the card that you removed, remove a different card, and then restart the computer.</li> <li>Repeat this process for each card. If the computer starts normally, troubleshoot the last card removed from the computer for resource conflicts.</li> <li>If the problem persists, contact Dell. For information about contacting Dell, see your <i>Owner's Manual</i>.</li> </ol>
①②③④	Routine system activity subsequent to video initialization.	Watch your monitor for on-screen messages.
①②③④	System resource configuration in progress.	None.
①②③④	System board failure has occurred.	Contact Dell. For information about contacting Dell, see your <i>Owner's Manual</i> .
①②③④	<p>During normal operation, all of the diagnostic lights turn on and then turn off before the system starts.</p> <p><b>NOTE:</b> If all of the diagnostic lights are on and the system does not start, there may be a problem with the power supply or with the processor.</p>	<p>If the system does not start, plug the computer into a working electrical outlet. Also see <a href="#">System Lights</a>.</p> <p>If there are no power problems and the system does not start, contact Dell. For information about contacting Dell, see your <i>Owner's Manual</i>.</p>

## Beep Codes

Your computer might emit a series of beeps during start-up if the monitor cannot display errors or problems. This series of beeps, called a beep code, identifies a problem. One possible beep code consists of one long beep and then two short beeps. This beep code tells you that the computer encountered a memory test failure.

If your computer beeps during start-up:

- Write down the beep code on the Diagnostics Checklist. The Diagnostics Checklist is located in your *Owner's Manual*.
- Run the Dell Diagnostics to identify a more serious cause. See [Dell Diagnostics](#).
- Contact Dell for technical assistance. For information about contacting Dell, see your *Owner's Manual*.

Code	Cause
2 short, 1 long	BIOS checksum error
1 long, 2 short	Memory test failure (bad memory during memory sizing)
1 long, 3 short, 2 short	No memory
1 short	F12 key pressed

[Back to Contents Page](#)