

SEARS

OWNER'S MANUAL

Model No.
200.71202



1.5 AMP FULLY AUTOMATIC ONBOARD BATTERY CHARGER MAINTAINER

CAUTION:

Read and Follow All Safety
Rules and Operating Instructions
Before Every Use of this Product.

Table Of Contents

Warranty	1	Using Your Battery Charger	4
Important Safety Instructions	2	What to expect from your charger	4
Before Using Your Battery Charger	3	Installing the charger	4
Plugging it in	3	Preparing your battery to be charged	5
Extension cords	3	Charging your battery	5
		Charging indicators	6
		Maintenance and care	6

Please read this Owner's Manual before using your Battery Charger

The Sears model 200.71202 Fully Automatic Onboard Battery Charger/Maintainer, offers features to accommodate the needs for home or light commercial use. This manual will show you how to use your charger safely and effectively. Please read and follow these instructions and precautions carefully.

Warranty

FULL TWO-YEAR WARRANTY

If, within two years from the date of purchase, this battery charger fails due to a defect in materials or workmanship, simply RETURN IT TO THE NEAREST SEARS STORE IN THE UNITED STATES, and Sears will repair or replace it, free of charge.

This warranty gives you specific legal rights, and you may also have other rights which vary from state to state.

Sears, Roebuck and Co., Dept 817WA,
Hoffman Estates, IL 60179

Important Safety Instructions

– SAVE THESE INSTRUCTIONS –

⚠ WARNING

To reduce the risk of explosion, explosive gases, or injury while using your battery charger, follow the precautions listed below:

- Read **all** instructions and cautions printed on the battery charger, battery, and vehicle or equipment using battery.
- Use charger only on **lead-acid** type rechargeable batteries, such as those used in cars, trucks, tractors, airplanes, vans, RV's, trolling motors, etc. This charger is not intended to supply power to a low voltage electrical system other than in an automotive application.
- **Use only** attachments recommended or sold by manufacturer. The use of attachments not recommended by the manufacturer may result in fire, electric shock, or injury.
- **Do not** disassemble charger. Take it to a qualified service professional if service or repair is required. Incorrect assembly may result in fire or electrical shock.
- To reduce risk of electrical shock, **unplug** the charger from the outlet before attempting any maintenance or cleaning.

Help us help you

Remember:

- **Place** charger as far away from battery being charged as the charger cables will permit.
- **Never** charge a frozen battery. If battery fluid (electrolyte) becomes frozen, bring battery into a warm area to thaw before you begin charging.
- **Never** allow battery acid to drip on charger when reading specific gravity or filling battery.
- **Never** set a battery on top of the charger.
- **Never** place charger directly above battery being charged.
- **Never** use charger for charging dry-cell batteries that are commonly used with home appliances. These batteries may burst and cause personal injury.
- **Never** operate charger if it has received a hard blow, been dropped, or otherwise damaged. Take it to a qualified professional for inspection and repair.
- **Never** pull out the plug by the cord when unplugging the charger. Pulling on the cord may cause damage to the cord or the plug.
- **Do not** operate the charger if it has a damaged power cord or plug. Have the cord replaced.
- **Never** crank engine with charger attached to battery and 120 volt line.

Personal Safety Precautions

For your own personal safety, please follow the following precautions:

- **Wear complete eye and clothing protection** when working with lead-acid batteries.
- **Be sure** that someone is within range of your voice to come to your aid if needed while you work with or are near a lead-acid battery.
- **Have plenty of fresh water and soap** nearby for use in case battery acid contacts your eyes, skin, or clothing. If this happens, wash immediately with soap and water. Then get medical attention.
- **Avoid touching your eyes** while working with a battery. Acid particles (corrosion) may get into your eyes. If this occurs, flush eyes immediately with running cold water for at least ten minutes. Then immediately get medical attention.
- **Remove all personal metal items** from your body, such as rings, bracelets, necklaces, and watches while working with a lead-acid battery. A battery can produce a short circuit current high enough to weld a ring (or the like) to metal, causing a severe burn.
- **Take care** not to drop any metal tool or metal object onto the battery. This may spark or short circuit the battery or another electrical device that may cause an explosion.
- **Always** operate your battery charger in an open, well ventilated area.
- **Never** smoke or allow a spark or flame in the vicinity of the battery or engine. Batteries generate explosive gases.
- **Neutralize** any acid spills thoroughly with baking soda before attempting to clean up.

Before Using Your Battery Charger

It is important to understand your charger's requirements. This section will tell you about your charger's electrical requirements and how to prepare a battery for charging.

Plugging it in

WARNING

Electrical Shock Hazard

Be sure that the power cord fits properly into the outlet. If not, have a qualified electrician install a proper outlet. Never alter the AC cord or plug provided. Improper connection can result in electrical shock.

Your charger should be grounded to reduce the risk of electrical shock.

Your charger is equipped with an electrical cord that has an equipment grounding conductor and a grounding plug designed to be used on a 120 volt circuit. The cord must be connected to an outlet that has been properly installed and grounded in accordance with all local codes and ordinances.

A **TEMPORARY** adapter may be used to connect the charger to a two-pole outlet if a properly grounded outlet is not available. Use the adapter **ONLY** until a properly grounded outlet can be installed by a qualified electrician.

DANGER: Before using an adapter as illustrated, be certain that the center screw of the outlet plate is grounded. The green colored grounding clip of the adapter must be attached by a screw to a properly grounded outlet. If unsure whether outlet is properly grounded, contact a professional electrician. If necessary, replace the original outlet cover screw with a longer one that will secure the grounding clip to the outlet cover and make a ground connection to the grounded outlet.

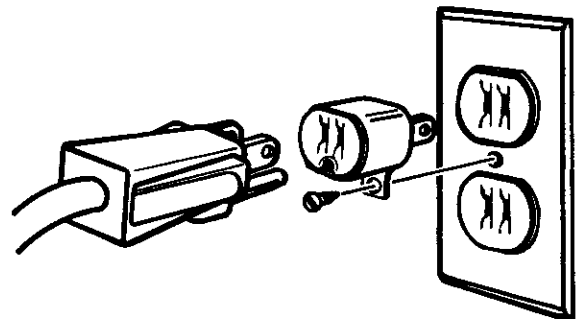
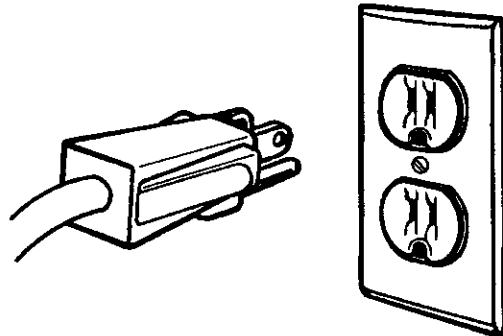

Extension cords

Improper extension cords present a risk of fire or electric shock. Follow these guidelines for using an extension cord:

- The pins on the charger's power cord must fit firmly into the extension cord, and the extension cord must fit firmly into the receptacle.
- Use only 3-conductor (grounded) extension cord when necessary.
- The extension cord must be properly wired and in good electrical condition.
- The wire size must be large enough for its length as specified in the following chart.

MINIMUM RECOMMENDED EXTENSION CORD				
Length of Cord, in Feet	25	50	100	150
AWG* Size of Cord	18	18	18	16

*AWG=American Wire Gauge

Using Your Battery Charger

For best results from your battery charger, learn to use it properly. This section tells how to install the charger and how to charge a battery in or out of the vehicle.

What to expect from your charger.

Your charger is designed for use with 12-volt batteries only. It has a control circuit designed to stop the charging process when a battery reaches full charge. This same circuit requires that a battery have at least 1 volt of charge to start the charging process. Completely discharged batteries must be brought to this minimum state-of-charge before this charger will operate.

The charger is designed to:

- maintain the charge level of 12-volt batteries used in seasonal or special-purpose vehicles or engines stored for long periods such as RVs, farm and construction equipment, snowmobiles and the like.
- improve 12-volt battery performance during cold weather.

Installing the charger

Location

Your charger can be mounted on a sheet-metal fender well near the battery.

The charger comes with a two-piece mounting bracket, two bolts, and two nuts. Position the charger on the selected location to be sure that the leads reach the battery terminals.

Mounting

Figure 1 illustrates the charger mounting brackets.

Figure 2 illustrates surface mounting of the charger to the fender well. If using the nut and bolt provided, drill two holes between 3/16" and 1/4" in diameter. (For alignment of holes use one of the brackets as a template.) If the backside of the mounting surface is hard to reach, you may consider using two 1/2" sheet-metal screws instead of nut and bolt, drill a pilot hole if required, drill holes between 1/8" and 5/32". **CAUTION:** Do not drill or puncture battery.

Electrical installations - Route and secure supply cord and output wiring away from gas line, carburetor or other hot, sharp or moving and pinch parts to avoid damage to the insulation. Secure the AC cord and plug to a cable or frame using a self locking cable tie or equivalent.

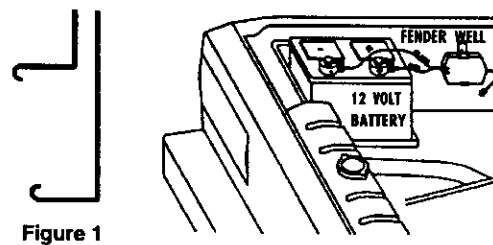
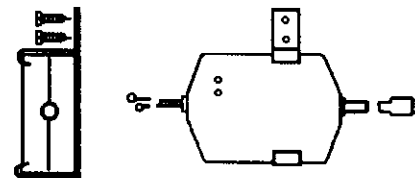

Figure 1

Figure 2



Preparing your battery to be charged

It is important that you read and follow these guidelines while you are preparing to charge your battery.

- Make sure that you have a 12 volt lead-acid battery.
- Clean the battery terminals. Be careful to keep corrosion from getting in or around your eyes.
- If you have a battery with removable cell caps, if required, add distilled water to each cell until the battery acid reaches the level indicated by the manufacturer. This will help purge excessive gases from the cells. Be careful not to overfill. If you have a sealed battery without cell caps, no action is necessary. Continue to the next step listed below.
- Take time to read all battery manufacturer's specific precautions, such as removing or not removing cell caps while charging, and recommended rates of charge.
- Wear safety glasses. See additional "Personal Safety Precautions" on page 2.
- Be sure that the area around the battery is well-ventilated while it is being charged.
- If it is necessary to remove the battery from the vehicle to charge it, always remove the grounded terminal from the battery first. A spark may be caused if all accessories in the vehicle are not completely turned off.

NOTE: A marine battery installed in a boat must be removed and charged on shore.

Charging your battery

ALWAYS DISCONNECT CHARGER FROM POWER SOURCE WHEN CONNECTING OR DISCONNECTING CHARGER TO OR FROM BATTERY.

Charging a battery in the vehicle:

1. Arrange the power cord and charging leads carefully to avoid damage that could be caused by the hood, door, or moving engine parts.
2. Keep your hands, leads and power cord clear of fan blades, belts, pulleys, and other parts that can cause injury.
3. Check the polarity of the battery posts as indicated on the battery case: POSITIVE (POS, P, or +) and NEGATIVE (NEG, N or -). **NOTE:** The positive post on top-post batteries is usually larger than the negative post.
4. Identify which battery post is ground or connected to the chassis. **THE NEGATIVE POST IS NORMALLY THE ONE THAT IS GROUNDED.**
5. On a negative grounded system:
Connect the red (POSITIVE) charger lead to the ungrounded POSITIVE (POS, P, +) cable connection to the battery. Then connect the black (NEGATIVE) lead to the grounded NEGATIVE (NEG, N, -) connection.
On a positive grounded system:
Connect the black (NEGATIVE) battery charger lead to the NEGATIVE (NEG, N, -) connection to the battery. Then connect the red (POSITIVE) lead to the grounded POSITIVE (POS, P, +) connection.
IMPORTANT: Wear safety glasses and face away from the battery while making connections.

Charging a battery outside the vehicle:

1. When removing battery, disconnect grounded terminal first. Be sure all accessories are turned off.
2. Check the polarity of the battery posts as indicated on the battery case: POSITIVE (POS, P, +) and NEGATIVE (NEG, N, -).
NOTE: On top-post batteries, the positive battery terminal usually has a larger diameter than the negative one.
3. Connect the red (POSITIVE) charger lead to the POSITIVE post of the battery, then connect NEGATIVE (-) black lead ring terminal to the NEGATIVE (-) post of the battery. **DO NOT** face battery when making final connection. Note: For top or side-post batteries, you will need to purchase connectors at an automotive accessory outlet.



**TOP-POST ADAPTER
REQUIRED FOR CONNECTION**

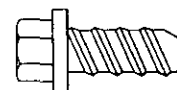

**SIDE-POST ADAPTER
REQUIRED FOR CONNECTION**

Charging indicators

Red and green lights indicate charger activity. When the charger is operating, indicator lights will show current activity:

COLOR	STATE	CONDITION
Green	Off	No power supply. Check connection to power source. Check lead connectons.
Green	On	AC power is connected.
Red	On	Battery voltage is about 14 volts and charging has stopped.
Red	Off	Battery voltage has dropped and charging has resumed

Maintenance and care

Very little maintence is needed. Keep the connections free of corrosion and accumulated soil.

SEARS

OWNER'S MANUAL

Model No.
200.71202

When requesting service or ordering parts, always provide the following information:

- Product Type
- Model Number
- Part Number
- Part Description

1.5 AMP FULLY AUTOMATIC ONBOARD BATTERY CHARGER MAINTAINER

For information about troubleshooting
Call toll-free from anywhere in the U.S.A.
7 am to 4:30 pm CST Monday through Friday

1-800-SEARS-64
(1-800-732-7764)

For the repair or replacement
parts you need

Call 7 am - 7 pm, 7 days a week

1-800-366-PART
(1-800-366-7278)



For the location of a Sears Repair
Service Center in your area

Call 24 hours a day,
7 days a week

1-800-488-1222



SEARS
REPAIR SERVICES
America's Repair Specialists