

TOSHIBA

Tecra[®] A2 Series User's Guide

If you need assistance:

- ❖ Toshiba Global Support Centre
Calling within the United States (800) 457-7777
Calling from outside the United States (949) 859-4273

For more information, see [“If Something Goes Wrong”](#) on [page 185](#) in this guide.

▲ WARNING

Handling the cord on this product will expose you to lead, a chemical known to the State of California to cause birth defects or other reproductive harm. ***Wash hands after handling.***

Models: Tecra® A2 Series

ReWritable CD/DVD Drives

The computer system you purchased may include a ReWritable CD and/or DVD drive(s), among the most advanced data storage technologies available. As with any new technology, you must read and follow all set-up and usage instructions in the applicable user guides and/or manuals enclosed. If you fail to do so, this product may not function properly and you may lose data or suffer other damage.

TOSHIBA AMERICA INFORMATION SYSTEMS (“TOSHIBA”), ITS AFFILIATES AND SUPPLIERS DO NOT WARRANT THAT OPERATION OF THE PRODUCT WILL BE UNINTERRUPTED OR ERROR FREE. YOU AGREE THAT TOSHIBA, ITS AFFILIATES AND SUPPLIERS SHALL HAVE NO RESPONSIBILITY FOR DAMAGE TO OR LOSS OF ANY BUSINESS, PROFITS, PROGRAMS, DATA OR REMOVABLE STORAGE MEDIA ARISING OUT OF OR RESULTING FROM THE USE OF THE PRODUCT, EVEN IF ADVISED OF THE POSSIBILITY THEREOF.

Protection of Stored Data

For your important data, please make periodic back-up copies of all the data stored on the hard disk or other storage devices as a precaution against possible failures, alteration, or loss of the data. **IF YOUR DATA IS ALTERED OR LOST DUE TO ANY TROUBLE, FAILURE OR MALFUNCTION OF THE HARD DISK DRIVE OR OTHER STORAGE DEVICES AND THE DATA CANNOT BE RECOVERED, TOSHIBA SHALL NOT BE LIABLE FOR ANY DAMAGE OR LOSS OF DATA, OR ANY OTHER DAMAGE RESULTING THEREFROM. WHEN COPYING OR TRANSFERRING YOUR DATA, PLEASE BE SURE TO CONFIRM WHETHER THE DATA HAS BEEN SUCCESSFULLY COPIED OR TRANSFERRED. TOSHIBA DISCLAIMS ANY LIABILITY FOR THE FAILURE TO COPY OR TRANSFER THE DATA CORRECTLY.**

Critical Applications

The computer you have purchased is not designed for any “critical applications.” “Critical applications” means life support systems, medical applications, connections to implanted medical devices, commercial transportation, nuclear facilities or systems or any other applications where product failure could lead to injury to persons or loss of life or catastrophic property damage.

ACCORDINGLY, TOSHIBA, ITS AFFILIATES AND SUPPLIERS DISCLAIM ANY AND ALL LIABILITY ARISING OUT OF THE USE OF THE COMPUTER PRODUCTS IN ANY CRITICAL APPLICATIONS. IF YOU USE THE COMPUTER PRODUCTS IN A CRITICAL APPLICATION, YOU, AND NOT TOSHIBA, ASSUME FULL RESPONSIBILITY FOR SUCH USE.

FCC Notice “Declaration of Conformity Information”

This equipment has been tested and found to comply with the limits for a Class B digital device, pursuant to Part 15 of the FCC rules. These limits are designed to provide reasonable protection against harmful interference in a residential installation.

This equipment generates, uses and can radiate radio frequency energy and, if not installed and used in accordance with the instructions, it may cause harmful interference to radio communications. However, there is no guarantee that interference will not occur in a particular installation. If this equipment does cause harmful interference to radio or television reception, which can be determined by turning the equipment off and on, the user is encouraged to try to correct the interference by one or more of the following measures:

- ❖ Reorient or relocate the receiving antenna.
- ❖ Increase the separation between the equipment and receiver.
- ❖ Connect the equipment to an outlet on a circuit different from that to which the receiver is connected.
- ❖ Consult the dealer or an experienced radio/TV technician for help.

NOTE

Only Peripherals complying with the FCC Class B limits may be attached to this equipment. Operation with noncompliant peripherals or peripherals not recommended by Toshiba is likely to result in interference to radio and TV reception. Shielded cables must be used between the external devices and the computer's parallel port, monitor port, USB port, PS/2 port®, i.LINK® port and microphone jack. Changes or modifications made to this equipment not expressly approved by Toshiba or parties authorized by Toshiba could void the user's authority to operate the equipment.

This device complies with Part 15 of the FCC Rules. Operation is subject to the following two conditions:

- ❖ This device may not cause harmful interference.
- ❖ This device must accept any interference received, including interference that may cause undesired operation.

Contact:

Toshiba America Information Systems, Inc.

9740 Irvine Blvd.

Irvine, CA 92618-1697

(949) 583-3000

Industry Canada requirement

This Class B digital apparatus complies with Canadian ICES-003.

Cet appareil numérique de la classe B est conforme à la norme NMB-003 du Canada.

FCC requirements

The following information is pursuant to FCC CFR 47, Part 68 and refers to internal modems.

This equipment complies with Part 68 of the FCC rules. On the bottom of this equipment is a label that contains, among other information, the FCC registration number and ringer equivalence number (REN) for this equipment. If requested, the information must be provided to the telephone company.

The modem connects to the telephone line by means of a standard jack called the USOC RJ11C.

A plug and jack used to connect this equipment to the premises wiring and telephone network must comply with the applicable FCC part 68 rules and requirements adopted by the ACTA. It is designed to be connected to a compatible modular jack that is also compliant.

The REN is used to determine the number of devices that may be connected to a telephone line. Excessive RENs on a telephone line may result in the devices not ringing in response to an incoming call. In most but not all areas, the sum of RENs should not exceed five (5.0). To be certain of the number of devices that may be connected to a line, as determined by the total RENs, contact the local telephone company. For products approved after July 23, 2001, the REN for this product is part of the product identifier that has the format US:AAAEQ##TXXXX. The digits represented by the ## are the REN without a

decimal point (e.g., 03 is a REN of 0.3). For earlier products, the REN is separately shown on the label.

Connection to party line service is subject to state tariffs. Contact the state public utility commission, public service commission or corporation commission for information.

Telephone Company Procedures

The goal of the telephone company is to provide you with the best service it can. In order to do this, it may occasionally be necessary for them to make changes in their equipment, operations or procedures. If these changes might affect your service or the operation of your equipment, the telephone company will give you notice, in writing, to allow you to make any changes necessary to maintain uninterrupted service.

If Problems Arise

If this equipment causes harm to the telephone network, the telephone company will notify you in advance that temporary discontinuance of service may be required. But if advanced notice is not practical, the telephone company will notify the customer as soon as possible. Also, you will be advised of your right to file a complaint with the FCC if you believe it is necessary.

If trouble is experienced with this equipment, for repair or limited warranty information, please contact Toshiba Corporation, Toshiba America Information Systems, Inc. or an authorized representative of Toshiba, or the Toshiba Support Centre within the United States at (800) 457-7777 or Outside the United States at (949) 859-4273. If the equipment is causing harm to the telephone network, the telephone company may request that you disconnect the equipment until the problem is resolved.

Disconnection

If you should ever decide to permanently disconnect your modem from its present line, please call the telephone company and let them know of this change.

Fax Branding

The Telephone Consumer Protection Act of 1991 makes it unlawful for any person to use a computer or other electronic device, including Fax machines, to send any message unless such message clearly contains in a margin at the top or bottom of each transmitted page or on the first page of the transmission, the date and time it is sent and an identification of the business or other entity, or other individual sending the message and the telephone number of the sending machine or such business, other entity, or individual. (The telephone number

provided may not be a 900 number or any other number for which charges exceed local or long-distance transmission charges.)

In order to program this information into your fax transmission, refer to the fax software instructions installed on this computer.

Alarm Equipment

If your home has specially wired alarm equipment connected to the telephone line, ensure the installation of this equipment does not disable your alarm equipment. If you have questions about what will disable alarm equipment, consult your telephone company or a qualified installer.

Instructions for IC CS-03 Certified Equipment

- 1** NOTICE: The Industry Canada label identifies certified equipment. This certification means that the equipment meets certain telecommunications network protective, operational and safety requirements as prescribed in the appropriate Terminal Equipment Technical Requirements document(s). The Department does not guarantee the equipment will operate to the user's satisfaction.

Before installing this equipment, users should ensure that it is permissible to be connected to the facilities of the local telecommunications company. The equipment must also be installed using an acceptable method of connection. The customer should be aware that compliance with the above conditions may not prevent degradation of service in some situations.

Repairs to certified equipment should be coordinated by a representative designated by the supplier. Any repairs or alterations made by the user to this equipment, or equipment malfunctions, may give the telecommunications company cause to request the user to disconnect the equipment.

Users should ensure for their own protection that the electrical ground connections of the power utility, telephone lines and internal metallic water pipe system, if present, are connected together. This precaution may be particularly important in rural areas.

Caution: Users should not attempt to make such connections themselves, but should contact the appropriate electric inspection authority, or electrician, as appropriate.

- 2** The user manual of analog equipment must contain the equipment's Ringer Equivalence Number (REN) and an explanation notice similar to the following:

The Ringer Equivalence Number (REN) of this device can be found on the label affixed to your computer.

NOTICE: The Ringer Equivalence Number (REN) assigned to each terminal device provides an indication of the maximum number of terminals allowed to be connected to a telephone interface. The termination on an interface may consist of any combination of devices subject only to the requirement that the sum of the Ringer Equivalence Numbers of all the devices does not exceed 5.

- 3 The standard connecting arrangement (telephone jack type) for this equipment is jack type(s): USOC RJ11C.

Wireless Interoperability

The TOSHIBA Wireless LAN Mini PCI Card products are designed to be interoperable with any wireless LAN product that is based on Direct Sequence Spread Spectrum (DSSS) radio technology, and is compliant to:

- ❖ The IEEE 802.11 Standard on Wireless LANs (Revision A/B/G), as defined and approved by the Institute of Electrical and Electronics Engineers.
- ❖ The Wireless Fidelity (Wi-Fi) certification as defined by the Wi-Fi Alliance. The “Wi-Fi CERTIFIED” logo is a certification mark of the Wi-Fi Alliance.

CAUTION

Bluetooth™ and Wireless LAN devices operate within the same radio frequency range and may interfere with one another. If you use Bluetooth™ and Wireless LAN devices simultaneously, you may occasionally experience a less than optimal network performance or even lose your network connection.

If you should experience any such problem, immediately turn off your Bluetooth™ or Wireless LAN device.

Please contact Toshiba PC product support on Web site <http://www.toshiba-europe.com/computers/tnt/bluetooth.htm> in Europe or <http://www.pcsupport.global.toshiba.com> in the United States for more information.

CAUTION

This device is restricted to indoor use due to its operation in the 5.15 GHz to 5.25 GHz frequency range.

Wireless LAN and your Health

Wireless LAN products, like other radio devices, emit radio frequency electromagnetic energy. The level of energy emitted by Wireless LAN devices however is far much less than the electromagnetic energy emitted by wireless devices like for example mobile phones.

Because Wireless LAN products operate within the guidelines found in radio frequency safety standards and recommendations, TOSHIBA believes Wireless LAN is safe for use by consumers. These standards and recommendations reflect the consensus of the scientific community and result from deliberations of panels and committees of scientists who continually review and interpret the extensive research literature.

In some situations or environments, the use of Wireless LAN may be restricted by the proprietor of the building or responsible representatives of the organization. These situations may for example include:

- ❖ Using the Wireless LAN equipment on board of airplanes, or
- ❖ In any other environment where the risk of interference to other devices or services is perceived or identified as harmful.

If you are uncertain of the policy that applies on the use of wireless devices in a specific organization or environment (e.g. airports), you are encouraged to ask for authorization to use the Wireless LAN device prior to turning on the equipment.

Regulatory Information

The TOSHIBA Wireless LAN Mini PCI Card must be installed and used in strict accordance with the manufacturer's instructions as described in the user documentation that comes with the product. This device complies with the following radio frequency and safety standards.

Canada – Industry Canada (IC)

This device complies with RSS 210 of Industry Canada.

CAUTION

The installer of this radio equipment must ensure that the antenna is located or pointed such that it does not emit RF field in excess of Health Canada limits for the general population; consult Safety Code 6, obtainable from Health Canada's Web site www.hc-sc.gc.ca/rpb. The RF device shall not be co-located with any other transmitter that has not been tested with this device.

Operation is subject to the following two conditions: (1) this device may not cause interference, and (2) this device must accept any interference, including interference that may cause undesired operation of this device.

L'utilisation de ce dispositif est autorisée seulement aux conditions suivantes: (1) il ne doit pas produire de brouillage et (2) l'utilisateur du dispositif doit être prêt à accepter tout brouillage radioélectrique reçu, même si ce brouillage est susceptible de compromettre le fonctionnement du dispositif.

The term "IC" before the equipment certification number only signifies that the Industry Canada technical specifications were met.

To prevent radio interference to the licensed service, this device is intended to be operated indoors and away from windows to provide maximum shielding. Equipment (or its transmit antenna) that is installed outdoors is subject to licensing.

Pour empêcher que cet appareil cause du brouillage au service faisant l'objet d'une licence, il doit être utilisé à l'intérieur et devrait être placé loin des fenêtres afin de fournir un écran de blindage maximal. Si le matériel (ou son antenne d'émission) est installé à l'extérieur, il doit faire l'objet d'une licence.

CAUTION

This device is restricted to indoor use due to its operation in the 5.15 GHz to 5.25 GHz frequency range. Industry Canada requires this product to be used indoors for frequency range 5.15 GHz to 5.25 GHz to reduce the potential for harmful interference to co-channel Mobile Satellite systems.

High power radars are allocated as primary users of the 5.25 GHz to 5.35 GHz and 5.65 GHz to 5.85 GHz bands. These radar stations can cause interference with and/or damage this device.

Europe – EU Declaration of Conformity

❖ This device complies with the essential requirements of the R&TTE Directive 1999/5/EC with essential test suites as per standards:

EN 60950 Safety of Information Technology equipment

ETS 300 328 Technical requirements for radio equipment

ETS 300 826 General EMC requirements for radio equipment.

English:

Hereby, TOSHIBA Corp. Digital Media Network Company, declares that this Radio LAN device is in compliance with the essential requirements and other relevant provisions of Directive 1999/5/EC.

Finnish:	Valmistaja TOSHIBA Corp. Digital Media Network Company vakuuttaa täten että Radio LAN device tyyppinen laite on direktiivin 1999/5/EY oleellisten vaatimusten ja sitä koskevien direktiivin muiden ehtojen mukainen.
Dutch:	Hierbij verklaart TOSHIBA Corp. Digital Media Network Company dat het toestel Radio LAN device in overeenstemming is met de essentiële eisen en de andere relevante bepalingen van richtlijn 1999/5/EG.
	Bij deze TOSHIBA Corp. Digital Media Network Company dat deze Radio LAN device voldoet aan de essentiële eisen en aan de overige relevante bepalingen van Richtlijn 1999/5/EC.
French:	Par la présente TOSHIBA Corp. Digital Media Network Company déclare que l'appareil Radio LAN device est conforme aux exigences essentielles et aux autres dispositions pertinentes de la directive 1999/5/CE.
	Par la présente, TOSHIBA Corp. Digital Media Network Company déclare que ce Radio LAN device est conforme aux exigences essentielles et aux autres dispositions de la directive 1999/5/CE qui lui sont applicables.
Swedish:	Härmed intygar TOSHIBA Corp. Digital Media Network Company att denna Radio LAN device står i överensstämmelse med de väsentliga egenskapskrav och övriga relevanta bestämmelser som framgår av direktiv 1999/5/EG.
Danish:	Undertegnede TOSHIBA Corp. Digital Media Network Company erklærer herved, at følgende udstyr Radio LAN device overholder de væsentlige krav og øvrige relevante krav i direktiv 1999/5/EF
German:	Hiermit erkläre TOSHIBA Corp. Digital Media Network Company, dass sich dieser/diese/dieses Radio LAN device in Übereinstimmung mit den grundlegenden Anforderungen und den anderen relevanten Vorschriften der Richtlinie 1999/5/EG befindet". (BMW)
	Hiermit erkläre TOSHIBA Corp. Digital Media Network Company die Übereinstimmung des Gerätes Radio LAN device mit den grundlegenden Anforderungen und den anderen relevanten Festlegungen der Richtlinie 1999/5/EG. (Wien)
Greek:	ΜΕ ΤΗΝ ΠΑΡΟΥΣΑ ΤΟSHIBA Corp. Digital Media Network Company ΔΗΛΩΝΕΙ ΟΤΙ Radio LAN device ΣΥΜΜΟΡΦΩΝΕΤΑΙ ΠΡΟΣ ΤΙΣ ΟΥΣΙΩΔΕΙΣ ΑΠΑΙΤΗΣΕΙΣ ΚΑΙ ΤΙΣ ΛΟΙΠΕΣ ΣΧΕΤΙΚΕΣ ΔΙΑΤΑΞΕΙΣ ΤΗΣ ΟΔΗΓΙΑΣ 1999/5/ΕΚ
Italian:	Con la presente TOSHIBA Corp. Digital Media Network Company dichiara che questo Radio LAN device è conforme ai requisiti essenziali ed alle altre disposizioni pertinenti stabilite dalla direttiva 1999/5/CE.

Spanish:	Por medio de la presente TOSHIBA Corp. Digital Media Network Company declara que el Radio LAN device cumple con los requisitos esenciales y cualesquiera otras disposiciones aplicables o exigibles de la Directiva 1999/5/CE.
Portuguese:	TOSHIBA Corp. Digital Media Network Company declara que este Radio LAN device está conforme com os requisitos essenciais e outras disposições da Directiva 1999/5/CE.

USA – Federal Communications Commission (FCC)

This device complies with Part 15 of FCC Rules. Operation of the devices in a Wireless LAN System is subject to the following two conditions:

- ❖ This device may not cause harmful interference.
- ❖ This device must accept any interference that may cause undesired operation.

TOSHIBA is not responsible for any radio or television interference caused by unauthorized modification of the devices included with this TOSHIBA Wireless LAN Mini PCI Card, or the substitution or attachment of connecting cables and equipment other than specified by TOSHIBA.

The correction of interference caused by such unauthorized modification, substitution or attachment will be the responsibility of the user.

Caution: Exposure to Radio Frequency Radiation

The radiated output power of the TOSHIBA Wireless LAN Mini PCI Card is far below the FCC radio frequency exposure limits. Nevertheless, the TOSHIBA Wireless LAN Mini PCI Card shall be used in such a manner that the potential for human contact during normal operation is minimized. In normal operating configuration, the LCD in the upright position, the distance between the antenna and the user should not be less than 20 cm. The antenna(s) used for this transmitter must not be co-located or operating in conjunction with any other antenna or transmitter. Antenna(s) used in 5.15 GHz to 5.25 GHz frequency band must be integral antenna which provide no access to the end user.

Refer to the Regulatory Statements as identified in the documentation that comes with those products for additional information.

Caution: Radio Frequency Interference Requirements

This device is restricted to indoor use due to its operation in the 5.15 GHz to 5.25 GHz frequency range. FCC requires this product to be used indoors for frequency range 5.15 GHz to 5.25 GHz to reduce the potential for harmful interference to co-channel Mobile Satellite systems.

High power radars are allocated as primary users of the 5.25 GHz to 5.35 GHz and 5.65 GHz to 5.85 GHz bands. These radar stations can cause interference with and/or damage this device.

NOTE

The above Caution information applies to products that operate with an 802.11a device.

Taiwan

Article 14	Unless approved, for any model accredited low power radio frequency electric machinery, any company, trader or user shall not change the frequency, increase the power or change the features and functions of the original design.
Article 17	Any use of low power radio frequency electric machinery shall not affect the aviation safety and interfere with legal communications. In event that any interference is found, the use of such electric machinery shall be stopped immediately, and reusing of such products can be resumed until no interference occurs after improvement.

The legal communications mentioned in the above item refer to radio communications operated in accordance with telecommunication laws and regulations.

Low power radio frequency electric machinery shall resist against interference from legal communications or from industrial, scientific and medical radio emission electric machinery.

Using this Equipment in Japan

In Japan, the frequency bandwidth of 2,400 MHz to 2,483.5 MHz for second generation low-power data communication systems such as this equipment overlaps that of mobile object identification systems (premises radio station and specified low-power radio station).

1. Sticker

Please put the following sticker on devices incorporating this product.

In the frequency bandwidth of this equipment, industrial device, scientific device, medical device like microwave oven, licensed premises radio station and non-licensed specified low-power radio station for mobile object identification system (RF-ID) that is used in product line of factories.(Other Radio Stations) are used.

- 1 Please make sure before using this equipment that no Other Radio Stations are used in the neighborhood.
- 2 In case that RF interference occurs to Other Radio Stations from this equipment, please change promptly the frequency for use, place to use, or stop emitting Radio.
- 3 Please contact TOSHIBA Direct PC if you have a problem, such as interference from this equipment to Other Radio Stations

2. Indication

The indication shown below appears on this equipment.

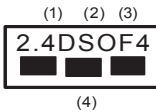

- 1** 2.4: This equipment uses a frequency of 2.4 GHz.
- 2** DS: This equipment uses DS-SS modulation.
OF: This equipment uses OFDM modulation.
- 3** The interference range of this equipment is less than 40m.
- 4** ■ ■ ■ This equipment uses a frequency bandwidth from 2,400 MHz to 2,483.5 MHz.

It is possible to avoid the band of mobile object identification systems.

3. TOSHIBA Direct PC

Monday – Friday: 10:00 – 17:00

Toll Free Tel: 0120-13-1100

Direct Dial: 03-3457-5916

Fax: 03-5444-9450

Device Authorization

This device obtains the Technical Regulation Conformity Certification and the Technical Conditions Compliance Approval, and it belongs to the device class of radio equipment of low-power data communication system radio station stipulated in the Radio Law and the Telecommunications Business Law of Japan.

The Name of the radio equipment: refer to the equipment label provided on the computer

JAPAN APPROVALS INSTITUTE FOR TELECOMMUNICATIONS
EQUIPMENT

Approval Number: D01-1128JP

TELECOM ENGINEERING CENTER Approval Number: 03NY.A0018,
03GZDA0017

The following restrictions apply:

- ❖ Do not disassemble or modify the device.
- ❖ Do not install the embedded wireless module into other device.
- ❖ 5.17 GHz to 5.23 GHz for indoor use only

Radio approvals for wireless devices

NOTE The following information is dependent on what type of wireless device is in your computer.

Approved Countries/Regions for use for the Atheros AR5BMB-43/44 Mini PCI Wireless network adapter

This equipment is approved to the radio standard by the countries/regions in the following table.

CAUTION Do not use this equipment except in the countries/regions in the following table.

NOTE This device works on passive scan only.
A peer-to-peer mode is not available in 802.11a and Turbo Mode.

802.11b (2.4 GHz)

Australia	Austria	Belgium
Canada	Denmark	Finland
France	Germany	Greece
Ireland	Italy	Liechtenstein
Luxembourg	Netherlands	New Zealand
Norway	Portugal	Sweden
Switzerland	UK	USA

Europe - Restrictions for use of 2.4 GHz Frequencies in European Community Countries

België/ Belgique:	For private usage outside buildings across public grounds over less than 300m no special registration with IBPT/BIPT is required. Registration to IBPT/BIPT is required for private usage outside buildings across public grounds over more than 300m. For registration and license please contact IBPT/BIPT.
	Voor privé-gebruik buiten gebouw over publieke grond over afstand kleiner dan 300m geen registratie bij BIPT/IBPT nodig; voor gebruik over afstand groter dan 300m is wel registratie bij BIPT/IBPT nodig. Voor registratie of licentie kunt u contact opnemen met BIPT.
	Dans le cas d'une utilisation privée, à l'extérieur d'un bâtiment, au-dessus d'un espace public, aucun enregistrement n'est nécessaire pour une distance de moins de 300m. Pour une distance supérieure à 300m un enregistrement auprès de l'IBPT est requise. Pour les enregistrements et licences, veuillez contacter l'IBPT.
Deutschland:	License required for outdoor installations. Check with reseller for procedure to follow.
	Anmeldung im Outdoor-Bereich notwendig, aber nicht genehmigungspflichtig. Bitte mit Händler die Vorgehensweise abstimmen.
France:	Restricted frequency band: only channels 1 to 7 (2400 MHz and 2454 MHz respectively) may be used outdoors in France. Please contact A.R.T. (http://www.art-telecom.fr) for applicable procedures to follow.
	Bande de fréquence restreinte: seuls les canaux 1- 7 (2400 et 2454 MHz respectivement) doivent être utilisés endroits extérieur en France. Vous pouvez contacter l'Autorité de Régulation des Télécommunications (http://www.art-telecom.fr) pour la procédure à suivre.
Italia:	License required for indoor use. Use with outdoor installations not allowed.
	E' necessaria la concessione ministeriale anche per l'uso interno. Verificare con i rivenditori la procedura da seguire.
Nederland:	License required for outdoor installations. Check with reseller for procedure to follow.
	Licentie verplicht voor gebruik met buitenantennes. Neem contact op met verkoper voor juiste procedure.

802.11a (5 GHz)

Australia	Austria	Belgium
Canada	Denmark	Finland
France	Germany	Greece
Ireland	Italy	Liechtenstein
Luxembourg	Netherlands	New Zealand
Norway	Portugal	Sweden
Switzerland	UK	USA

Turbo Mode (5 GHz)

Canada	USA	
--------	-----	--

Europe - Restrictions for use of 5 GHz Frequencies in European Community Countries

European Community Countries	5150-5250 MHz Channels: 36, 40, 44, 48 Indoor Only	5250-5350 MHz Channels: 52, 56, 60, 64 Indoor Only	5470-5725 MHz Channels: 100, 104, 108, 112, 116, 120, 124, 128, 132, 136, 140 Indoor/Outdoor
Austria	O	x	x
Belgium, France, Switzerland/Lichtenstein	O	O	x
Denmark, Finland, Germany, Greece, Ireland, Italy, Luxembourg, Netherlands, Norway, Portugal, Sweden, UK	O	O	O
Iceland, Spain	O	O	O

O: allowed x: forbidden

- ❖ To remain in conformance with European spectrum usage laws for Wireless LAN operation, the above 2.4 GHz and 5 GHz channel limitations apply. The user should use the wireless LAN utility to check the current channel of operation. If operation is occurring outside of the allowable frequencies as listed above, the user must cease operating the Wireless LAN at that location and consult the local technical support staff responsible for the wireless network.
- ❖ The 5 GHz Turbo mode feature is not allowed for operation in any European Community country.

- ❖ This device must not be operated in ad-hoc mode using channels in the 5 GHz bands in the European Community. Ad-hoc mode provides a direct communication between two client devices without a Wireless LAN Access Point.
- ❖ This device must be used with Access Points that have employed and activated a radar detection feature required for European Community operation in the 5 GHz bands. This device will operate under the control of the Access Point in order to avoid operating on a channel occupied by any radar system in the area. The presence of nearby radar operation may result in temporary interruption of operation of this device. The Access Point's radar detection feature will automatically restart operation on a channel free of radar. You may consult with the local technical support staff responsible for the wireless network to ensure the Access Point device(s) are properly configured for European Community operation.

Approved Countries/Regions for use for the Atheros AR5001X Mini PCI Wireless network adapter

This equipment is approved to the radio standard by the countries/regions in the following table.

CAUTION

Do not use this equipment except in the countries/regions in the following table.

NOTE

This device works on passive scan only.

A peer-to-peer mode is not available in 802.11a and Turbo Mode.

802.11b (2.4 GHz)

Australia	Austria	Belgium
Canada	Denmark	Finland
France	Germany	Greece
Ireland	Italy	Liechtenstein
Luxembourg	Netherlands	New Zealand
Norway	Portugal	Sweden
Switzerland	UK	USA

802.11a (5 GHz)

Australia	Austria	Belgium
Canada	Denmark	Finland
France	Germany	Greece
Ireland	Italy	Liechtenstein
Luxembourg	Netherlands	New Zealand
Norway	Portugal	Sweden
Switzerland	UK	USA

Turbo Mode (5 GHz)

Canada	USA	
--------	-----	--

Approved Countries/Regions for use for the Intel® PRO/ Wireless LAN 2100 3B Mini PCI Adapter

This equipment is approved to the radio standard by the countries/regions in the following table.

CAUTION

Do not use this equipment except in the countries/regions in the following table.

Argentina	Australia	Austria
Belgium	Brazil	Canada
Chile	Denmark	Finland
France	Germany	Greece
Iceland	Ireland	Italy
Japan	Liechtenstein	Luxembourg
Mexico	Netherlands	New Zealand
Norway	Peru	Portugal
Singapore	Spain	Sweden
Switzerland	UK	Uruguay
USA	Venezuela	

Approved Countries/Regions for use for the Toshiba Mini PCI Wireless LAN Card

This equipment is approved to the radio standard by the countries/regions in the following table.

CAUTION

Do not use this equipment except in the countries/regions in the following table.

Australia	Austria	Belgium
Canada	Denmark	Finland
France	Germany	Greece
Hong Kong	Iceland	Ireland
Italy	Japan	Liechtenstein
Luxembourg	Malaysia	Netherlands
New Zealand	Norway	Philippines
Portugal	Singapore	Spain
Sweden	Switzerland	Thailand
UK	USA	

Bluetooth wireless technology Interoperability

Bluetooth™ Cards from TOSHIBA are designed to be interoperable with any product with Bluetooth wireless technology that is based on Frequency Hopping Spread Spectrum (FHSS) radio technology, and is compliant to:

- ❖ Bluetooth Specification as defined and approved by The Bluetooth Special Interest Group.
- ❖ Logo certification with Bluetooth wireless technology as defined by The Bluetooth Special interest Group.

CAUTION

Bluetooth wireless technology is a new innovative technology, and TOSHIBA has not confirmed compatibility of its Bluetooth™ products with all PCs and/or equipment using Bluetooth wireless technology other than TOSHIBA portable computers.

Always use Bluetooth™ cards from TOSHIBA in order to enable wireless networks over two or more (up to a total of seven) TOSHIBA portable computers using these cards. Please contact TOSHIBA PC product support on Web site <http://www.toshiba-europe.com/computers/tnt/bluetooth.htm> in Europe or <http://www.pcsupport.global.toshiba.com> in the United States for more information.

When you use Bluetooth™ cards from TOSHIBA close to 2.4 GHz Wireless LAN devices, Bluetooth transmissions might slow down or cause errors. If you detect certain interference while you use Bluetooth™ cards from TOSHIBA, always change the frequency, move your PC to the area outside of the interference range of 2.4 GHz Wireless LAN devices (40 meters/43.74 yards or more) or stop transmitting from your PC. Please contact TOSHIBA PC product support on Web site <http://www.toshiba-europe.com/computers/tnt/bluetooth.htm> in Europe or <http://www.pcsupport.global.toshiba.com> in the United States for more information.

Bluetooth™ and Wireless LAN devices operate within the same radio frequency range and may interfere with one another. If you use Bluetooth™ and Wireless LAN devices simultaneously, you may occasionally experience a less than optimal network performance or even lose your network connection. If you should experience any such problem, immediately turn off either one of your Bluetooth™ or Wireless LAN. Please contact Toshiba PC product support on Web site <http://www.toshiba-europe.com/computers/tnt/bluetooth.htm> in Europe or <http://www.pcsupport.global.toshiba.com> in the United States for more information.

Bluetooth wireless technology and your Health

The products with Bluetooth wireless technology, like other radio devices, emit radio frequency electromagnetic energy. The level of energy emitted by devices with Bluetooth wireless technology however is far much less than the electromagnetic energy emitted by wireless devices like for example mobile phones.

Because products with Bluetooth wireless technology operate within the guidelines found in radio frequency safety standards and recommendations, TOSHIBA believes Bluetooth wireless technology is safe for use by consumers. These standards and recommendations reflect the consensus of the scientific

community and result from deliberations of panels and committees of scientists who continually review and interpret the extensive research literature.

In some situations or environments, the use of Bluetooth wireless technology may be restricted by the proprietor of the building or responsible representatives of the organization. These situations may for example include:

- ❖ Using the equipment with Bluetooth wireless technology on board of airplanes, or
- ❖ In any other environment where the risk of interference to other devices or services is perceived or identified as harmful.

If you are uncertain of the policy that applies on the use of wireless devices in a specific organization or environment (e.g. airports), you are encouraged to ask for authorization to use the device with Bluetooth wireless technology prior to turning on the equipment.

Regulatory statements

This product complies with any mandatory product specification in any country/region where the product is sold. In addition, the product complies with the following:

European Union (EU) and EFTA

This equipment complies with the R&TTE directive 1999/5/EC and has been provided with the CE mark accordingly.

Canada — Industry Canada (IC)

This device complies with RSS 210 of Industry Canada.

Operation is subject to the following two conditions: (1) this device may not cause interference, and (2) this device must accept any interference, including interference that may cause undesired operation of this device.”

L'utilisation de ce dispositif est autorisée seulement aux conditions suivantes: (1) il ne doit pas produire de brouillage et (2) l'utilisateur du dispositif doit être prêt à accepter tout brouillage radioélectrique reçu, même si ce brouillage est susceptible de compromettre le fonctionnement du dispositif.

The term “IC” before the equipment certification number only signifies that the Industry Canada technical specifications were met.

Caution: FCC Interference Statement

This device complies with part 15 of the FCC rules. Operation is subject to the following two conditions:

- ❖ This device may not cause harmful interference, and
- ❖ This device must accept any interference received, including interference that may cause undesired operation.

Note that any changes or modifications to this equipment not expressly approved by the manufacturer may void the authorization to operate this equipment.

Caution: Exposure to Radio Frequency Radiation

The radiated output power of the Bluetooth™ Card from TOSHIBA is far below the FCC radio frequency exposure limits. Nevertheless, the Bluetooth™ Card from TOSHIBA shall be used in such a manner that the potential for human contact during normal operation is minimized.

In order to comply with FCC radio-frequency radiation exposure guidelines for an uncontrolled environment, the Bluetooth™ Card from TOSHIBA has to be operated while maintaining a minimum body to antenna which are located on top of LCD distance of 20 cm.

Refer to the Regulatory Statements as identified in the documentation that comes with those products for additional information.

The Bluetooth™ Card from TOSHIBA is far below the FCC radio frequency exposure limits.

Nevertheless, it is advised to use the Bluetooth™ Card from TOSHIBA in such a manner that human contact during normal operation is minimized.

NOTE

Changes or modifications made to this equipment not expressly approved by TOSHIBA or parties authorized by TOSHIBA could void the user's authority to operate the equipment.

Taiwan

Article 14	Unless approved, for any model accredited low power radio frequency electric machinery, any company, trader or user shall not change the frequency, increase the power or change the features and functions of the original design.
Article 17	Any use of low power radio frequency electric machinery shall not affect the aviation safety and interfere with legal communications. In event that any interference is found, the use of such electric machinery shall be stopped immediately, and reusing of such products can be resumed until no interference occurs after improvement.

The legal communications mentioned in the above item refer to radio communications operated in accordance with telecommunication laws and regulations.

Low power radio frequency electric machinery shall resist against interference from legal communications or from industrial, scientific and medical radio emission electric machinery.

Using this equipment in Japan

In Japan, the frequency bandwidth of 2,400 MHz to 2,483.5 MHz for second generation low-power data communication systems such as this equipment overlaps that of mobile object identification systems (premises radio station and specified low-power radio station).

1. Sticker

Please put the following sticker on devices incorporating this product.

In the frequency bandwidth of this equipment, industrial device, scientific device, medical device like microwave oven, licensed premises radio station and non-licensed specified low-power radio station for mobile object identification system (RF-ID) that is used in product line of factories,(Other Radio Stations) are used.

- 1 Please make sure before using this equipment that no Other Radio Stations are used in the neighborhood.
- 2 In case that RF interference occurs to Other Radio Stations from this equipment, please change promptly the frequency for use, place to use, or stop emitting Radio.
- 3 Please contact TOSHIBA Direct PC if you have a problem, such as interference from this equipment to Other Radio Stations

2. Indication

The indication shown below appears on this equipment.

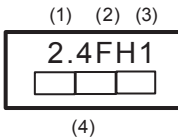

- 1** 2.4: This equipment uses a frequency of 2.4 GHz.
- 2** FH: This equipment uses FH-SS modulation.
- 3** The interference range of this equipment is less than 10m.
- 4** This equipment uses a frequency bandwidth from 2,400 MHz to 2,483.5 MHz. It is impossible to avoid the band of mobile object identification systems.

3. TOSHIBA Direct PC

Monday – Friday: 10:00 – 17:00

Toll Free Tel: 0120-13-1100

Direct Dial: 03-3457-5916

Fax: 03-5444-9450

Device Authorization

This device obtains the Technical Regulation Conformity Certification, and it belongs to the device class of radio equipment of low-power data communication system radio station stipulated in the Radio Law of Japan.

The Name of the radio equipment: EYXF2CS

TELECOM ENGINEERING CENTER

Approval Number: 01NYDA1305

The following restrictions apply:

- ❖ Do not disassemble or modify the device.
- ❖ Do not install the embedded wireless module into other device.

DVD-ROM, multi-function drive safety instructions

The DVD-ROM and multi-function drives employ a laser system. To ensure proper use of this product, please read this instruction manual carefully and retain for future reference. Should the unit ever require maintenance, contact an authorized service location.

Use of controls, adjustments or the performance of procedures other than those specified may result in hazardous radiation exposure.

To prevent direct exposure to the laser beam, do not try to open the enclosure.

Location of the required label

(Sample shown below. Location of the label and manufacturing information may vary.)

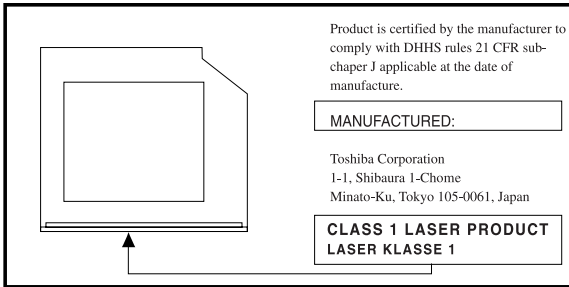

CAUTION

This appliance contains a laser system and is classified as a “CLASS 1 LASER PRODUCT.” To use this model properly, read the user’s guide carefully and keep it for your future reference. In case of any trouble with this model, please contact your nearest “AUTHORIZED service station.” To prevent direct exposure to the laser beam, do not try to open the enclosure.

CLASS 1 LASER PRODUCT
LASER KLASSE 1

Use of controls or adjustments or performance of procedures other than those specified in the owner’s manual may result in hazardous radiation exposure.

Copyright

This guide is copyrighted by Toshiba America Information Systems, Inc. with all rights reserved. Under the copyright laws, this guide cannot be reproduced in any form without the prior written permission of Toshiba. No patent liability is assumed, however, with respect to the use of the information contained herein.

©2004 by Toshiba America Information Systems, Inc. All rights reserved.

Export Administration Regulation

This document contains technical data that may be controlled under the U.S. Export Administration Regulations, and may be subject to the approval of the U.S. Department of Commerce prior to export. Any export, directly or indirectly, in contravention of the U.S. Export Administration Regulations is prohibited.

Notice

The information contained in this manual, including but not limited to any product specifications, is subject to change without notice.

TOSHIBA CORPORATION AND TOSHIBA AMERICA INFORMATION SYSTEMS, INC. (TOSHIBA) PROVIDES NO WARRANTY WITH REGARD TO THIS MANUAL OR ANY OTHER INFORMATION CONTAINED HEREIN AND HEREBY EXPRESSLY DISCLAIMS ANY IMPLIED WARRANTIES OF MERCHANTABILITY OR FITNESS FOR ANY PARTICULAR PURPOSE WITH REGARD TO ANY OF THE FOREGOING. TOSHIBA ASSUMES NO LIABILITY FOR ANY DAMAGES INCURRED DIRECTLY OR INDIRECTLY FROM ANY TECHNICAL OR TYPOGRAPHICAL ERRORS OR OMISSIONS CONTAINED HEREIN OR FOR DISCREPANCIES BETWEEN THE PRODUCT AND THE MANUAL. IN NO EVENT SHALL TOSHIBA BE LIABLE FOR ANY INCIDENTAL, CONSEQUENTIAL, SPECIAL, OR EXEMPLARY DAMAGES, WHETHER BASED ON TORT, CONTRACT OR OTHERWISE, ARISING OUT OF OR IN CONNECTION WITH THIS MANUAL OR ANY OTHER INFORMATION CONTAINED HEREIN OR THE USE THEREOF.

Trademarks

Tecra and Noteworthy are registered trademarks, FreedomWare and SmartMedia are trademarks, of Toshiba America Information Systems, Inc. and/or Toshiba Corporation.

Microsoft and Windows are registered trademarks of Microsoft Corporation in the United States and/or other countries.

DirectX, Active Desktop, DirectShow, and Windows Media are registered trademarks of Microsoft Corporation.

ConfigFree is a trademark of Toshiba Corporation.

Wi-Fi is a registered trademark of the Wi-Fi Alliance.

Dolby - Manufactured by Toshiba under license from Dolby Laboratories/ Dolby and the double-D symbol are trademarks of Dolby Laboratories.

TouchPad is a trademark of Synaptics, Inc.

All other brand and product names are trademarks or registered trademarks of their respective companies.

Computer disposal information

This product contains mercury. Disposal of this material may be regulated due to environmental considerations. For disposal, reuse or recycling information, please contact your local government or the Electronic Industries Alliance at www.eiae.org.

Contents

Introduction.....	36
This guide	37
Safety icons	38
Other icons used	39
Other documentation	39
Service options	40
Chapter 1: Getting Started.....	41
Selecting a place to work	41
Creating a computer-friendly environment.....	41
Keeping yourself comfortable	42
Other precautions	46
Important information on your computer's cooling fan	46
Setting up your computer	47
Setting up your software.....	48
Registering your computer with Toshiba	49
Setting up other devices	49
Connecting to a power source	49
Charging the main battery.....	52

Using the computer for the first time	53
Opening the display panel	53
Your computer's features and specifications	54
Turning on the power	54
Adding memory	55
Installing a memory module	56
Removing a memory module	60
Hard Drive Recovery Utilities	62
Creating Recovery CDs/DVDs	63
Hard Disk Drive Recovery using the recovery partition	64
Hard Disk Drive Recovery using the Recovery media	67
Deleting the Hard Disk Recovery Utility.....	70
Installing drivers and applications.....	71
Using the TouchPad™	72
Scrolling with the TouchPad™	73
Control buttons	73
Disabling or enabling the TouchPad	73
Turning off the computer	75
Closing the display panel	76
Using external display devices	76
Directing the display output when you turn on the computer	77
Adjusting the quality of the external display.....	78
Using an external keyboard	78
Using a mouse	78
Connecting a local printer	79
Connecting an optional external diskette drive.....	81
Connecting external speakers or headphones.....	82
Connecting a microphone	82

Chapter 2: Learning the Basics	83
Computing tips	83
Using the keyboard	85
Character keys	85
Making your keyboard emulate a full-size key- board	86
Ctrl, Fn, and Alt keys	86
Function keys	86
Windows special keys	87
Overlay keys	87
Using the overlay to type numeric data	88
Starting a program	89
Starting a program from the Start menu	90
Starting a program from Windows® Explorer	90
Starting a program from the Run dialog box	91
Saving your work	93
Printing your work	95
Using the DVD-ROM or multi-function drive	96
Inserting a compact disc	98
Removing a disc with the computer on	100
Removing a disc with the computer off	100
Caring for CD or DVD Discs	100
Using PC Cards	101
Hot swapping	101
Using your computer at the office	102
Using a computer lock	102
Caring for your computer	103
Cleaning the computer	103
Moving the computer	104
Backing up your work	104
Restoring your work	105
Preparing for communications	105
Powering down the computer	106
Using Turn Off Computer or Shut Down	106

Using Hibernation	109
Using Standby	111
Toshiba's online resources	113
Chapter 3: Mobile Computing.....	114
Toshiba's energy-saver design.....	114
Running the computer on battery power	115
Battery Notice	115
Charging the batteries.....	116
Charging the main battery.....	117
Charging the RTC battery.....	117
Monitoring battery power	119
What to do when the battery alarm sounds	121
Changing batteries	122
Taking care of your battery	124
Safety precautions	124
Maximizing battery life	125
Disposing of used batteries	127
Conserving power	128
Power profiles in Windows XP.....	129
Using a hot key to set the power profile.....	129
Additional options for power.....	130
Chapter 4: Expansion Options.....	131
Devices for office computing	131
Using an external keyboard.....	132
Using a mouse	132
Connecting a USB mouse	132
Using a printer	132
Setting up your printer.....	133
Using the Wi-Fi® Wireless LAN Mini PCI module..	136
Using an expansion device.....	136

Chapter 5: Enhancing Productivity	138
Exploring the desktop	138
Finding your way around the desktop	139
Setting up for communications	142
Connecting the modem to a telephone line	143
Connecting your computer to a network	143
An overview of using the Internet	146
The Internet	146
The World Wide Web	146
Internet Service Providers	147
Connecting to the Internet	147
Surfing the Internet	148
Internet features	148
Uploading and downloading files from the Internet	149
Exploring audio features	149
Playing an audio CD	149
Playing CDs using Auto-Run	151
Creating a CD	151
Recording sounds	152
Using external speakers or headphones	153
Inserting and removing hard drives	154
Inserting and removing PC Cards	156
Inserting a PC Card	156
Removing a PC Card	157
Setting up a PC Card for your computer	158
Connecting your modem to a telephone line	158
Connecting to a phone line	159

Chapter 6: Toshiba Utilities.....	160
Fn-esse®	161
Starting Fn-esse®	161
Using the keyboard or pointing device to assign keys	163
Viewing existing key assignments	164
Changing or removing existing key assignments	164
TOSHIBA Console	165
Customizing Your Computer	166
Network	166
Security.....	166
TOSHIBA Power Saver	166
Mouse utility	168
Hotkey utility	169
TOSHIBA Mobile Extension.....	169
TOSHIBA HW Setup.....	171
Enabling Hibernation.....	173
Setting user passwords	174
Using an instant password.....	175
Setting a user password	175
Disabling a user password	176
Using a supervisor password.....	176
Setting a supervisor password.....	176
Deleting a supervisor password	177
Using the TOSHIBA Zooming Utility.....	178
Using the TOSHIBA Touch and Launch utility	179
TOSHIBA Application Installer.....	183

Chapter 7: If Something Goes Wrong.....	185
Problems that are easy to fix	185
Problems when you turn on the computer.....	187
The Windows® operating system is not working...	188
Using Startup options to fix problems	189
Internet problems	190
The Windows® XP operating system can help you	190
Resolving a hardware conflict	191
A plan of action	191
Resolving hardware conflicts on your own	192
Fixing a problem with Device Manager	193
Memory problems	195
Power and the batteries	195
Keyboard problems.....	197
Display problems	197
Disk drive problems.....	200
DVD-ROM or multi-function drive problems...	202
Sound system problems	203
PC Card problems.....	203
Printer problems	206
Modem problems.....	207
Develop good computing habits	208
If you need further assistance	209
Before you call	209
Contacting Toshiba	210
Other Toshiba Internet Web sites	211
Toshiba's worldwide offices.....	211

Appendix A: Hot Keys.....	213
Volume Mute	213
Instant password security	214
Power usage profile	214
Stand By mode	215
Hibernation mode	216
Display modes	217
Display brightness	218
Disabling or enabling the TouchPad	218
Keyboard hot keys	218
Appendix B: Power Cord/Cable Connectors.....	219
Appendix C: Using ConfigFree™ with your Toshiba Computer	220
Getting Started	221
Starting ConfigFree	221
ConfigFree Utilities	222
Connectivity Doctor	222
Search for Wireless Devices	225
Profile Settings	227
Quick Connect.....	229
Using the Automatic Switch.....	232
Semi-Automatic Switch Feature	233
Glossary.....	234
Index.....	249

Introduction

Welcome to the world of powerful, portable multimedia computing. With your Toshiba notebook computer, your work can accompany you wherever you go.

Tecra® A2 Series computers provide considerable computing power, enabling you to perform the most demanding computing tasks from any location.

You will find your operating system, Microsoft® Windows® XP Professional, already installed on your computer. Your operating system offers exciting features and easy Internet access.

NOTE

The product specifications and configuration information are designed for a product Series. Your particular model may not have all the features and specifications listed or illustrated. For more detailed information about the features and specifications on your particular model, please visit Toshiba's Web site at pcsupport.toshiba.com.

While Toshiba has made every effort at the time of publication to ensure the accuracy of the information provided herein, product specifications, configurations, prices, system/component/options availability are all subject to change without notice. For the most up-to-date product information about your computer, or to stay current with the various computer software or hardware options, visit Toshiba's Web site at pcsupport.toshiba.com.

This guide

This guide introduces the computer's features. You can:

- ❖ Read the entire guide from beginning to end
- ❖ Skim through and stop when a topic interests you
- ❖ Use the table of contents and the index to find specific information

Safety icons

This manual contains safety instructions that must be observed in order to avoid potential hazards that could result in personal injuries, damage to your equipment, or loss of data. These safety cautions have been classified according to the seriousness of the risk, and the icons highlight these instructions as follows:

▲ DANGER

Indicates an imminently hazardous situation which, if not avoided, will result in death or serious injury.

▲ WARNING

Indicates a potentially hazardous situation which, if not avoided, could result in death or serious injury.

▲ CAUTION

Indicates a potentially hazardous situation which, if not avoided, may result in minor or moderate injury.

CAUTION

Indicates a potentially hazardous situation which, if not avoided, may result in property damage.

NOTE

Provides important information.

Other icons used

Additional icons highlight other helpful or educational information:



TECHNICAL NOTE: This icon indicates technical information about the computer.



HINT: This icon indicates helpful hints and tips.



DEFINITION: This icon indicates the definition of a term used in the text.

Other documentation

Your computer comes with the following documentation.

- ❖ This electronic user's guide.
- ❖ Guides for other programs that may come preinstalled on your computer or that are available for installation on your Recovery media (if applicable to your system).
- ❖ For accessory information, visit Toshiba's Web site at accessories.toshiba.com.
- ❖ The Microsoft® Windows® operating system documentation which explains the features of the operating system.

Service options

Toshiba offers a full line of optional service programs to complement its limited warranty. To stay current on the most recent software and hardware options for your computer, and for other product information, be sure to regularly check the Toshiba Web site at pcsupport.toshiba.com.

If you have a problem or need to contact Toshiba, see “[If Something Goes Wrong](#)” on page 185.

Chapter 1

Getting Started

This chapter provides tips for working comfortably, describes how to connect components, and explains what to do the first time you use your computer.

Selecting a place to work

Your computer is designed to be used in a variety of locations and situations. This section provides guidelines for setting up your computing environment.

Creating a computer-friendly environment

Place the computer on a flat surface that is large enough for the computer and any other items you need to use, such as a printer. Leave enough space around the computer and other equipment to give adequate ventilation, otherwise, they may overheat.

To keep your computer in prime operating condition, protect your work area from:

- ❖ Dust, moisture, and direct sunlight
- ❖ Liquids and corrosive chemicals

CAUTION

If you spill liquid into the computer, turn it off, unplug it from the AC power source and let it dry out completely before turning it on again.

If the computer does not operate properly after you turn it back on, contact a Toshiba service representative or your network administrator.

- ❖ Equipment that generates a strong electromagnetic field, such as large stereo speakers (other than speakers that are connected to the computer) or speakerphones.
- ❖ Rapid changes in temperature or humidity and sources of temperature change such as air conditioner vents or heaters.
- ❖ Extreme heat, cold, or humidity.

Keeping yourself comfortable

Strain and stress injuries are becoming more common as people spend more time using their computers. However, with a little care and the proper use of the equipment, you can work comfortably throughout the day.

WARNING

Using the computer keyboard incorrectly can result in discomfort and possible injury. If your hands, wrists, and/or arms hurt while typing, stop using the computer and rest. If the discomfort persists, consult a physician.

This section provides hints on avoiding strain and stress injuries. For more information, consult books on ergonomics, repetitive-strain injury, and repetitive-stress syndrome.

Placement of the computer

Proper placement of the computer and external devices is important to avoid stress-related injuries. Consider the following when placing your computer.

- ❖ Place the computer on a flat surface at a comfortable height and distance. You should be able to type without twisting your torso or neck and look at the screen without slouching.
- ❖ If you use an external monitor, the top of the screen should be no higher than eye level.
- ❖ If you use a paper holder, set it at the same height and distance as the screen.

Seating and posture

When using your computer, maintain good posture with your body relaxed and your weight distributed evenly. Proper seating is a primary factor in reducing work strain. Some people find a backless chair more comfortable than a conventional chair. Whichever type you choose, use the following guidelines to adjust your chair for maximum computing comfort.

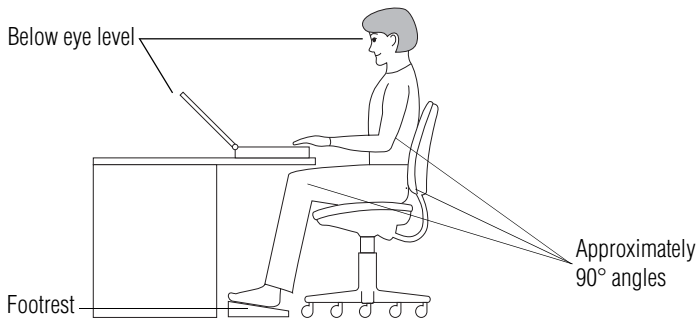

Correct posture and positioning of the computer

- ❖ Position your chair so that the keyboard is at or slightly lower than the level of your elbow. You should be able to

type comfortably with your shoulders relaxed and your forearms parallel to the floor.

If you are using a conventional chair:

- ❖ Your knees should be slightly higher than your hips. If necessary, use a footrest to raise the level of your knees and ease the pressure on the back of your thighs.
- ❖ Adjust the back of your chair so that it supports the lower curve of your spine. If necessary, use a cushion to provide extra back support. Lower-back-support cushions are available at many office supply stores.
- ❖ Sit with your back straight so that your knees, hips, and elbows form approximately 90-degree angles when you work. Do not slump forward or lean back too far.

Lighting

Proper lighting can improve the readability of the display and reduce eyestrain.

- ❖ Position the display panel or external monitor so that sunlight or bright indoor lighting does not reflect off the screen. Use tinted windows or shades to reduce glare.
- ❖ Avoid placing your computer in front of a bright light that shines directly into your eyes.
- ❖ If possible, use soft, indirect lighting in your computer work area.

CAUTION

Your LCD display has a brightness approaching that of a TV device. We recommend that you adjust the brightness of your LCD to a comfortable level to prevent possible strain on your eyes.

Arms and wrists

- ❖ Avoid bending, arching, or twisting your wrists. Keep them in a relaxed, neutral position while typing.
- ❖ Exercise your hands, wrists and arms to improve circulation.

Work habits

The key to avoiding discomfort or injury from strain is to vary your activities. If possible, schedule a variety of tasks into your working day. Finding ways to break up the routine can reduce stress and improve your efficiency.

- ❖ Take frequent, short breaks to change position, stretch your muscles, and relieve your eyes. A break of two or three minutes every half hour is more effective than a long break after several hours.
- ❖ Avoid performing repetitive activities for long periods. Intersperse such activities with other tasks.
- ❖ Focusing your eyes on your computer screen for long periods can cause eyestrain. Look away from the computer frequently and focus your eyes on a distant object for at least 30 seconds.

CAUTION

Your LCD display has a brightness approaching that of a TV device. We recommend that you adjust the brightness of your LCD to a comfortable level to prevent possible strain on your eyes.

Other precautions

Your computer is designed to optimize safety, minimize strain, and withstand the rigors of portability. However, you should observe certain precautions to further reduce the risk of personal injury or damage to the computer.

CAUTION

Do not apply heavy pressure to the computer or subject it to sharp impacts. Excessive pressure or impact can damage computer components or cause your computer to malfunction.

CAUTION

Some PC Cards can become hot with prolonged use. If two cards are installed, both can become hot even if only one is used extensively. Overheating of a PC Card can result in errors or instability in the PC Card operation.

Be careful when you remove a PC Card that has been used for lengthy periods of time.

Important information on your computer's cooling fan

Your computer may have a CPU cooling fan that cools the CPU by drawing outside air into the computer. The cooling fan may be located on the bottom of the computer.

CAUTION

To prevent possible overheating of the CPU, make sure the air intake on the cooling fan is not blocked. The fan draws in air by creating a vacuum. If the fan is blocked, it could cause the CPU to run at a lower performance level or cause the computer to shut down. Loose items such as notebook and tissue paper, plastic wrappers, or other similar materials can block the air intake, preventing air from reaching the CPU. Do not use the computer on surfaces with objects that can be drawn in by the cooling fan.

NOTE

The cooling fan location will vary depending on the computer.

Setting up your computer



TECHNICAL NOTE: You must complete all set up steps up to [“Setting up your software” on page 48](#) before adding external or internal components to your computer. These components include, but are not limited to, a mouse, keyboard, printer, memory, and PC cards.

Your computer comes with a rechargeable battery pack that must be charged before you can use it.

To use external power or to charge the battery, you must attach the AC adapter. See [“Connecting to a power source” on page 49](#).

To register your computer online, or to sign up for an Internet account, you must be connected to the Internet using a modem or LAN connection.

Before adding any of these devices to the computer, be sure to complete [“Setting up your software” on page 48](#).

After setting up your computer, you may want to:

- ❖ Add more memory
- ❖ Connect a mouse
- ❖ Connect a full-size keyboard
- ❖ Connect an external monitor
- ❖ Connect a local printer
- ❖ Install PC Cards

Setting up your software

NOTE The names of windows displayed, and the order in which windows appear, may vary according to your software setup choices.

The first time you turn on your computer, the Setup Wizard guides you through steps to set up your software.

- 1** From the welcome screen, click Next to enter the Setup Wizard.
- 2** Confirm acceptance of Microsoft's End User License Agreement and click Next.
- 3** Enter your name and the name of your company or organization and click Next.

The computer will pause for a moment while checking for an internet connection.

A window will display the message "An Internet connection could not be chosen."

- 4** Enter the information about your computer.
-

NOTE If you are connecting your computer to a network, consult your system administrator before you choose your computer name and network settings.

- 5** Set the correct date, time and time zone for your computer and click Next.

Your computer restarts automatically.

Registering your computer with Toshiba

Product registration is strongly recommended, and allows Toshiba to send Customer periodic updates, announcements, and special offers applicable to the product. Product registration can be completed during the initial start up process of your computer. If you opt not to register at that time, you can either double-click the icon on your desktop or go to the Toshiba Web site at www.register.toshiba.com. Customer failure to complete Product Registration will not diminish Customer rights under this limited Warranty.

Setting up other devices

You may want to take this time to set up your printer. For more information, see “Setting up your printer” on page 133.

Connecting to a power source

Your computer requires power to operate. Use the power cord/cable and AC adapter to connect the computer to a live electrical outlet, or to charge the computer’s battery.

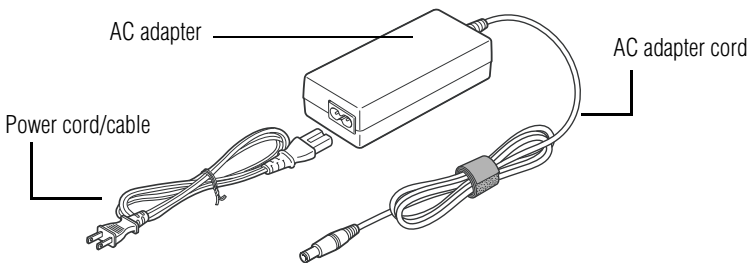

Sample power cord/cable and AC adapter

▲ WARNING Hold the power cord/cable by its plug when you connect/disconnect it. Do NOT pull the cable itself. Doing so may damage the power cord/cable and result in a short circuit or electric shock.

▲ WARNING When you connect the AC adapter to the computer, always follow the steps in the exact order as described in the User's Manual. Connecting the power cord/cable to a live electrical outlet should be the last step; otherwise, the adapter DC output plug could hold an electrical charge and cause an electrical shock or minor bodily injury when touched. As a general safety precaution, avoid touching any metal parts.

CAUTION Use only the AC adapter supplied with your computer or an equivalent adapter that is compatible. Use of any incompatible adapter could damage your computer. Toshiba assumes no liability for any damage caused by use of an incompatible adapter.

To connect AC power to the computer:

- 1 Connect the power cord/cable to the AC adapter.

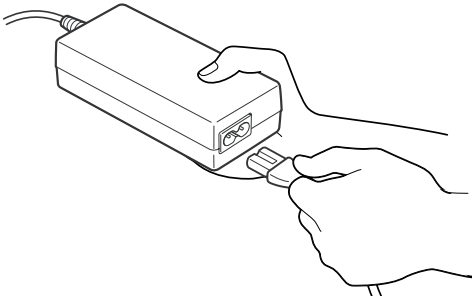

Sample connecting the power cord/cable to the AC adapter

⚠ WARNING

Handling the cord on this product will expose you to lead, a chemical known to the State of California to cause birth defects or other reproductive harm. **Wash hands after handling.**

- ② Plug the AC adapter cord into the DC-IN on the right side of the computer.

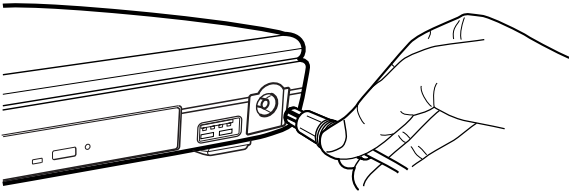

Sample connecting the AC adapter cord to the computer

- 3 Connect the power cord/cable to a live electrical outlet.

If the electrical outlet is live, the system indicator panel's AC power light (⚡) glows green.

If the main battery is present, the battery light (🔋) glows:

- ❖ Amber while the battery is charging
- ❖ Green when the battery is fully charged

If the battery light flashes amber during charging, either the battery pack is malfunctioning, or it is not receiving input from the AC power supply. Disconnect the AC cable and remove the battery pack. See [“If Something Goes Wrong” on page 185](#) for troubleshooting information.

▲ WARNING

Damaged power cables can cause fire or electric shock. Never modify, forcibly bend, place heavy objects on top of, or apply heat to the power cord/cable.

If the power cord/cable becomes damaged or the plug overheats, discontinue use. There is a risk of electric shock.

Never remove the power plug from the outlet with wet hands. Doing so may cause an electric shock.

Charging the main battery

Your computer came with its battery already installed. Before using the battery to power the computer, you must charge the battery.

To charge the battery, leave the computer plugged into an AC power source for at least three hours with the computer turned off. After that, the battery will be completely charged and ready to power the computer.

CAUTION

Once the battery is charged for the first time, avoid leaving the computer plugged in and turned off for more than a few hours at a time. Continuing to charge a fully charged battery can damage the battery.



TECHNICAL NOTE: When your computer is using all of the power provided by the AC Adaptor to run applications, features, and devices, the recharging of the battery can not occur. Your computer's Power Saver utility can be used to select a power level setting that reduces the power required for system operation and will allow the battery to recharge.

NOTE

Battery life and charge time may vary depending on the applications, power management settings, and features used.

Using the computer for the first time

The computer is now ready for you to turn it on and begin using it.

Opening the display panel

- 1 Slide the display latch to the right.
- 2 Lift the display panel.

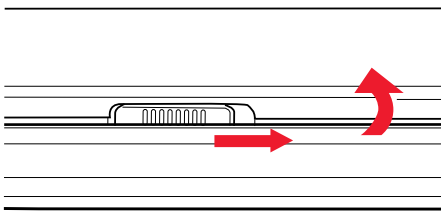

Sample opening the display panel

CAUTION

To avoid damaging the display panel, do not force it beyond the point where it moves easily, and never lift the computer by the display panel.

Small bright dots may appear on your TFT display when you turn on your computer. Your display contains an extremely large number of thin-film transistors (TFT) and is manufactured using high-precision technology. Any small bright dots that may appear on your display are an intrinsic characteristic of the TFT manufacturing technology.

NOTE

Over a period of time, and depending on the usage of the computer, the brightness of the LCD Screen will deteriorate. This is an intrinsic characteristic of LCD technology.

Screen will dim when the computer is operated on battery power and you may not be able to increase the brightness of the screen.

Your computer's features and specifications

Certain notebook chassis are designed to accommodate all possible configurations for an entire product Series. Your selected model may not have all the features and specifications corresponding to all of the icons or switches shown on the notebook chassis, unless you have selected all those features.

Below are examples of some of the many possible icons that may come on your computer:



Sample system icons

This information applies to all the features and icons described in this guide.

Turning on the power

To turn on the computer:

- 1 Make sure any external devices (such as the AC adapter, if you plan to use AC power rather than battery power) are properly connected and ready.
- 2 Check to ensure that all drives are empty.



- 3 Press and hold the power button in until the on/off light on the system indicator panel glows green—about one second.

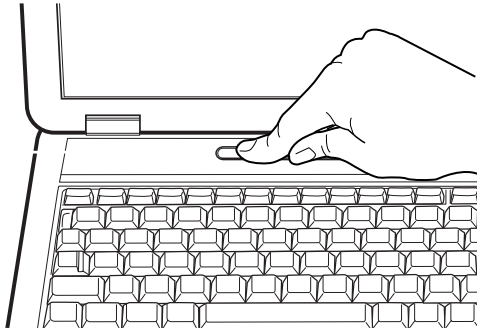

Sample turning on the power

The preinstalled operating system will load automatically.

CAUTION

When you turn on the computer for the first time, do not turn off the power again until the operating system has loaded completely.

Adding memory



HINT: To purchase additional memory modules, see the accessories information packaged with your system or visit accessories.toshiba.com.



Your Tecra® A2 Series computer comes with enough memory to run most of today's popular applications. You may want to increase the computer's memory if you use complex software or process large amounts of data.

For more information on memory options, check the accessories information that came with your computer, or visit accessories.toshiba.com.

Installing a memory module

Additional memory modules can be installed in the memory module slots on the base of the computer. You will need a standard Phillips no.1 screwdriver for this procedure.

CAUTION

To avoid damaging the computer's screws, use a standard Phillips no. 1 screwdriver that is in good condition.

CAUTION

Installing a memory module with the computer's power on may damage the computer, the module, or both.

The computer has two memory module slots — Slot A and Slot B. You can install one or two memory modules.

CAUTION

Before you install or remove a memory module, turn off the computer using the Start menu. If you install or remove a memory module while the computer is in Standby or Hibernation mode, data will be lost.

A memory module must be installed in slot A. Do not try to operate the computer with a memory module in slot B only.

If you install a memory module that is incompatible with the computer, a beep will sound when you turn on the computer. If the module is installed in slot A, there will be a long beep followed by a short beep. If the module is in slot B, there will be a long beep followed by two short beeps. In this case, turn off the computer and remove the incompatible module.

If the computer is on, begin at step 1; otherwise, skip to step 3.

- 1 If the computer is on, click **Start, Turn off computer**.

The Turn off computer window appears.

- 2 Click **Turn Off**.

The operating system turns off the computer.

- 3 Unplug and remove any cables connected to the computer.

- 4 Remove the battery. For information on removing the battery, see [“Changing batteries”](#) on page 122.

- 5 Close the display panel and turn the computer upside down to locate the memory module slot cover to the memory module slot.

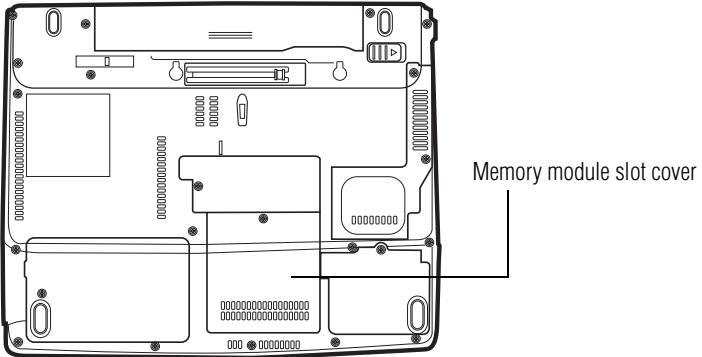

Sample locating the memory module slot cover

- 6 Using a standard Phillips no. 1 screwdriver, unscrew the screw that secures the memory module slot cover, then remove the memory slot cover.

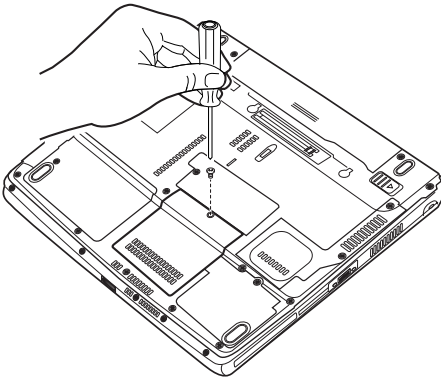

Memory module slot cover

Sample removing the memory module slot cover

- 7 Place the screw and the cover in a safe place so that you can retrieve them later.

CAUTION

Static electricity can damage the memory module. Before you handle the module, touch a grounded metal surface to discharge any static electricity you may have built up.

To avoid damaging the memory module, be careful not to touch its pin connector on the side you insert into the computer.

- 8 Remove the new memory module from its antistatic packaging.
- 9 Holding the memory module by its edges so that the gold connector bar faces the slot, fit the module into the socket.
- 10 Gently press down on the memory module connector until the clips snap into place.

Do not force the memory module into position. The memory module should be level when secured in place.

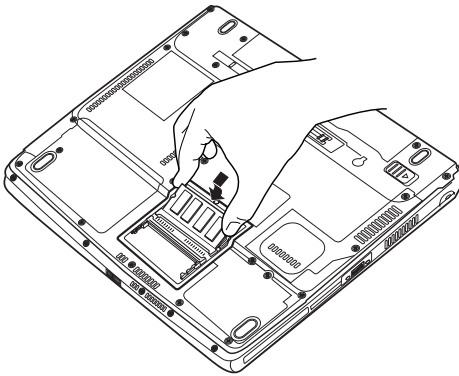

Sample inserting the memory module into the slot

The clips on either side of the memory module will click to secure the memory module.

CAUTION

Avoid touching the connectors on the memory module or on the computer. Grease or dust on the connectors may cause memory access problems.

- 11** Replace the memory module slot cover and screw.
- 12** Turn the computer over and restart it.

You can now continue setting up the computer. When the operating system has loaded, you can verify that the computer has recognized the additional memory module.

If you are adding an extra memory module after setting up the computer, verify that the computer has recognized it correctly as described in [“Checking total memory” on page 61](#).

Removing a memory module

If you need to remove a memory module:

- 1 Complete steps 1–6 in ““Installing a memory module”” to shut down the computer and open the memory module slot cover.

CAUTION

Do not try to remove a memory module with the computer turned on. You can damage the computer and the device.

Do not remove the memory module while the computer is in Standby mode. The computer could hang up the next time you turn it on and data in memory will be lost. In either of the above cases, the Standby configuration will not be saved.

The following message appears when you turn on the power:

Warning: Resume Failure
Press Any Key To Continue

If the computer hangs up when you turn it on, perform the following: Press the power button and hold it down for five seconds, then turn the power on again.

- 2 Pull the clips away from the memory module.
The memory module pops partially out of the slot.
- 3 Carefully remove the memory module from the slot.

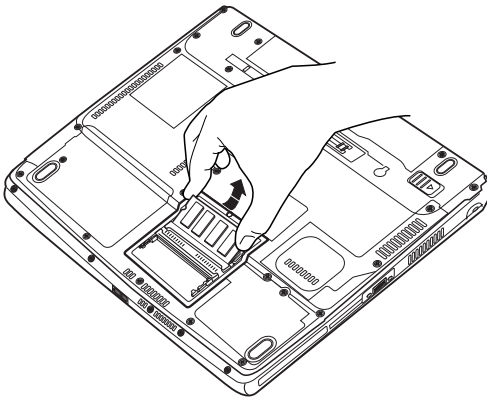

Sample removing the memory module

- 4 Replace the memory module slot cover and screw.
- 5 Turn the computer over and restart it.

Checking total memory

When you add or remove a memory module, you can check that the computer has recognized the change. To do this:

- 1 Click **Start**, then click **Control Panel**.
- 2 Click **Performance and Maintenance**.
- 3 Click **System**.
- 4 The **General** tab view automatically appears and shows total memory.

If the computer does not recognize the memory configuration, turn off the computer, remove the memory slot cover, and make sure the memory module is seated properly, as described in step 10 of “[Adding memory](#)” starting on page 55.

Hard Drive Recovery Utilities

Your computer has been configured with a hard disk partition to allow you to recover your hard disk drive or reinstall selected applications and software features or utilities.

NOTE

It is strongly recommended that you create recovery CDs/DVDs before using your system. For more information on creating Recovery media, see [“Creating Recovery CDs/DVDs” on page 63](#)

Using the HDD Recovery, you can:

- ❖ Create Hard Drive Recovery CDs or DVDs using a writable drive.
- ❖ Recover your hard disk drive to the factory-set default.
- ❖ Recover just your C: drive, leaving any other partitions you may have created intact, for example, a D: drive.
- ❖ Recover your hard disk drive to the factory-set default state without the HDD Recovery partition.
- ❖ Delete your hard disk drive recovery partition without the risk of losing your data
- ❖ Reinstall drivers and applications which were bundled with your computer.

Creating Recovery CDs/DVDs

Copying the Hard Drive Recovery Utilities to CD or DVD gives you the ability to recover your hard disk drive and reclaim additional hard disk space used to store the Hard Drive Recovery Utilities on your computer.

NOTE

The system will prompt you to insert the appropriate amount of CDs or DVDs to copy the Hard Drive Recovery Utilities. If your optical disk drive is not writable, contact TOSHIBA Customer Support to obtain the Recovery media for your system.

To create recovery CDs/DVDs:



- 1 Double-click the Recovery Disc Creator icon on the Windows desktop. You can also launch the application by clicking **Start, All Programs, then Hard Disk Recovery Utilities.**
- 2 Select CD, DVD, or All Files (to create Recovery media on both CDs and DVDs).

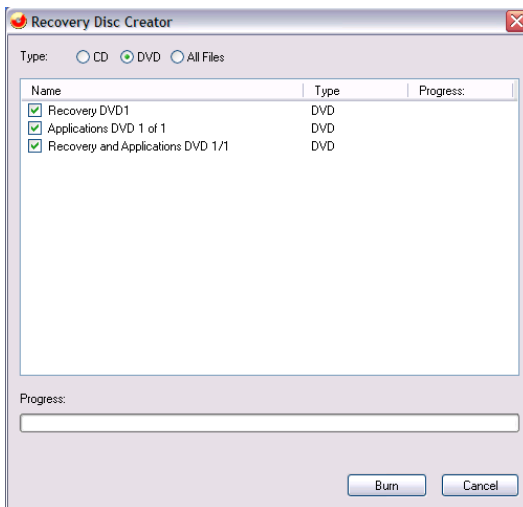

Sample Recovery Disc Creator screen

- 3 Select the items you want to copy by clicking the checkbox next to the item's Name – recovery files, applications (original bundled drivers and applications), or both the recovery files and applications.
- 4 Click **Burn**.
- 5 Insert the first CD or DVD into your computer's CD/DVD writable drive when prompted.
- 6 Follow the on-screen prompts for completing the copy process.

For more information on using the Recovery media you have created with the preceding steps, see [“Hard Disk Drive Recovery using the Recovery media”](#) on page 67.

Hard Disk Drive Recovery using the recovery partition

You have the options of recovering your system using the Hard Drive Recovery partition to the factory-set default, or recovering just your C: drive and leaving other partitions (for example, a D: drive) intact, or changing the size of your C: drive and then recovering it.

To recover your hard disk drive using the utilities stored on your computer's HDD:

- 1 Make sure the computer is turned off.
- 2 Press and hold the **0** (zero) key on your keyboard while powering on the computer. When the computer powers on, the TOSHIBA HDD Recovery Utility screen displays.

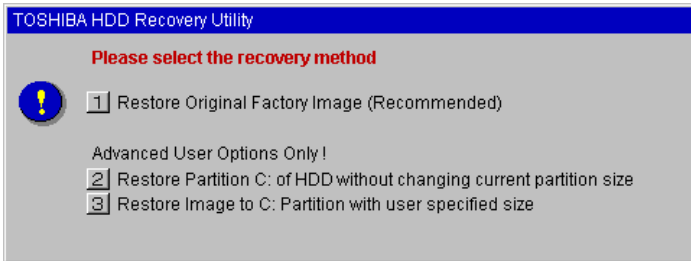

Sample TOSHIBA HDD Recovery Utility screen

Recovering the original factory image (recommended)

CAUTION

Recovering a hard disk drive to its factory default setting deletes all partitions on the hard disk drive and your information will be lost. Be sure to save your work first.

- 1 Press **1** on the keyboard to recover your hard disk drive to its original factory setting. A confirmation message displays reminding you that all data will be lost during the recovery process. Be sure you have saved your work before proceeding.
- 2 Click **Yes** to begin the recovery. Once complete, a message displays that the HDD has been recovered.
- 3 Press any key on the keyboard to restart the computer.

Recovering the C: partition of the HDD without changing the current partition size

CAUTION

Recovering the C: drive to its factory default setting reformats your drive and your information on the recovered drive will be lost. Be sure to save your work first. If you have created other partitions (for example, a D: drive) those partitions and any information on them will not be affected and remain intact.

To recover only your C: drive:

- 1 Press **2** on the keyboard when the TOSHIBA HDD Recovery Utility screen displays. A confirmation message appears, reminding you that all information on the C: drive will be lost during the recovery process. Be sure you have saved your work before proceeding.
- 2 Click **Yes** to begin the restoration. Once complete, a message displays that the HDD has been recovered.
- 3 Press any key on your keyboard to restart the computer.

Recovering the C: partition with a user specified size

CAUTION

Resizing and recovering your C: drive to its factory default setting reformats all partitions on the HDD (for example, if you created a D: drive, it will be deleted during the recovery process) and your information will be lost. Be sure to save your work first.

To resize and recover your C: drive:

- 1 Press **3** on the keyboard when the TOSHIBA HDD Recovery Utility screen displays. A confirmation message appears, reminding you that all partitions will be reformatted and all

information will be lost during the recovery process. Be sure you have saved your work before proceeding.

- 2 Click **Yes** to begin the restoration and to specify the size of the C: drive.
 - ❖ Press the Left/Right Arrow keys to increase/decrease the C: drive size by 1 GB.
 - ❖ Press the Up/Down Arrow keys to increase/decrease the C: drive size by 5 GB.
-

NOTE

The size of the C: drive will display on the progress bar as you make your selections.

- 3 Click **Enter** to begin the restoration. Once complete, a message displays that the HDD has been recovered.
- 4 Press any key on your keyboard to restart the computer.

Hard Disk Drive Recovery using the Recovery media

If you need to recover your computer to its default factory state, you can re-build the system using your Hard Drive Recovery Utilities.

To recover your hard disk drive using the utilities burned to CDs or DVDs (refer to [“Creating Recovery CDs/DVDs”](#) on page 63):

- ❖ Insert the first recovery CD or DVD into your CD/DVD drive and power on the computer. When the computer powers on, the TOSHIBA HDD Recovery Utility screen displays.

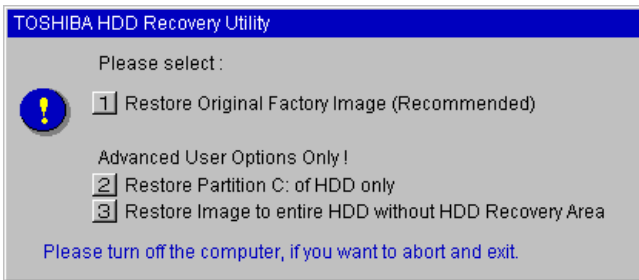

Sample TOSHIBA HDD Recovery Utility screen

Recovering the original factory image (recommended)

CAUTION

Recovering a hard disk drive to its factory default setting deletes all partitions on the hard disk drive and your information will be lost. Be sure to save your work first.

- 1 Press **1** on the keyboard to recover your hard disk drive to its original factory setting. A confirmation message displays, reminding you that all data will be lost during the recovery process. Be sure you have saved your work before proceeding.
- 2 Click **Yes** to begin the recovery process. Once complete, a message displays that the HDD has been recovered.
- 3 Press any key on the keyboard to restart the computer.

Recovering the C: partition of the HDD only

CAUTION

Recovering the C: drive to its factory default setting reformats your drive and your information on the recovered drive will be lost. Be sure to save your work first. If you have created other partitions (for example, a D: drive) those partitions and any information on them will not be affected and remain intact.

To recover only your C: drive:

- 1 Press **2** on the keyboard when the TOSHIBA HDD Recovery Utility screen displays. A confirmation message appears, reminding you that all information on the C: drive will be lost during the recovery process. Be sure you have saved your work before proceeding.
- 2 Click **Yes** to begin the restoration. Once complete, a message displays that the HDD has been recovered.
- 3 Press any key on your keyboard to restart the computer.

Recovering the entire HDD without the HDD Recovery Area

This option recovers your C: drive without creating the HDD Recovery Utilities partition. This will increase the size of your C: drive.

CAUTION

Recovering your C: drive to its factory default state without the recovery partition reformats all partitions on the HDD (for example, if you created a D: drive, it will be deleted during the recovery process) and your information will be lost. Be sure to save your work first.

To recover your C: drive without the recovery partition:

- 1 Press **3** on the keyboard when the TOSHIBA HDD Recovery Utility screen displays. A confirmation message appears, reminding you that all partitions will be reformatted and all data will be lost during the recovery process. Be sure you have saved your work before proceeding.
- 2 Click **Yes** to begin the restoration. Once complete, a message displays that the HDD has been recovered.
- 3 Press any key on your keyboard to restart the computer.

Checking the HDD operating status

After restoring your hard disk drive, you can check its status as follows:

- 1 Click **Start**, and then click **Control Panel**.
- 2 Double-click the **Administrative Tools** icon.
- 3 Double-click the **Computer Management** icon.
- 4 Click **Disk Management**.
- 5 Highlight the hard disk drive in the Volume list to display its status in the lower portion of the screen.

Deleting the Hard Disk Recovery Utility

You can delete the HDD recovery partition without losing your data.

- 1 Click **Start**, **All Programs**, **Hard Disk Recovery Utilities**, then **Delete Hard Disk Recovery Partition**. When the computer powers on, the Delete Hard Disk Recovery Utility warning screen displays.

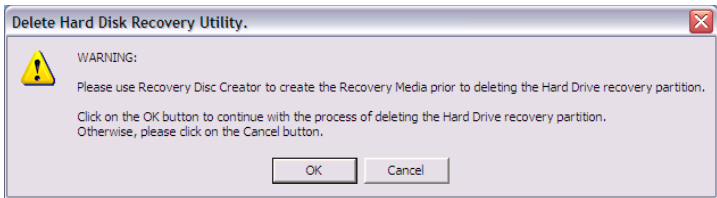

Sample Delete Hard Disk Recovery Utility screen

- 2 Click **OK** to continue.
- 3 When the following warning screen displays, click **OK** to confirm.

After the Delete Hard Disk Recovery Utility has completed, it assigns the appropriate drive letter (for example, E: drive) for the extra space and formats the drive.



Sample Delete Hard Disk Recovery Utility confirmation screen

Installing drivers and applications

The TOSHIBA Application Installer allows you to reinstall the drivers and applications that were originally bundled with your computer.

To reinstall drivers and applications:



- 1 Double-click the Toshiba Application Installer icon on the Windows desktop. You can also launch the application by

clicking **Start, All Programs**, then **Hard Disk Recovery Utilities**.

- 2 Click **Next**.
- 3 Click the item(s) you want to install.
- 4 Click **Install**.
- 5 Follow the on-screen prompts to complete the installation process.

Using the TouchPad™

The TouchPad, the small, smooth square cutout located in front of the keyboard, is sensitive to touch and enables you to move the cursor with the stroke of a finger. Simply move your finger on the TouchPad in the direction you would like to move the cursor:

- ❖ To move the cursor to the top of the page, push your finger forward on the TouchPad.
- ❖ To move the cursor to the bottom of the page, drag your finger toward yourself.
- ❖ To move the cursor to the right side of the page, slide your finger across the TouchPad from left to right.
- ❖ To move it to the left side, slide your finger from right to left.

NOTE

Because the TouchPad is much smaller than the display screen, moving your cursor across the screen often means having to move your finger several times across the TouchPad in the preferred direction.

Once you have positioned your cursor, you can click it into place by either double-tapping the TouchPad or clicking the control buttons.

Scrolling with the TouchPad™

There are two active regions on the TouchPad that allow you to scroll as you would with any wheel device on a mouse or trackball.

To scroll vertically, run your finger up or down along the right edge of the TouchPad. To scroll horizontally, run your finger along the bottom edge of the TouchPad.

Control buttons

When a step instructs you to click or choose an item, move the cursor to the item, then press and release the primary (left-hand) button. To double-click, press the primary button twice in rapid succession. The primary button usually corresponds to the left mouse button.

The function of the secondary (right-hand) button depends on the program you are using. It usually corresponds to the right mouse button. Check your program's documentation to find whether it uses the right mouse button.

Disabling or enabling the TouchPad

The TouchPad is enabled by default. To change the enable/disable TouchPad setting:

- 1 Click **Start**, and then **Control Panel**.

The Control Panel window appears.

- 2 Click **Printers and Other Hardware**.

- 3 Click the **Mouse** icon.

- 4 Click the **TouchPAD ON/OFF** tab.

The TouchPAD ON/OFF tab view window appears.

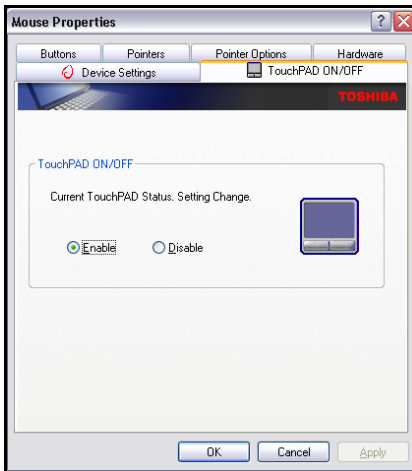

Sample TouchPAD ON/OFF screen

- 5 Select **Disable** or **Enable**, whichever is appropriate.
- 6 Click **Apply**.
- 7 Click **OK**.

The Mouse Properties window closes.

- 8 Close the Printers and Other Hardware window.
- 9 Close the Control Panel window.

You can also use a hot key to disable or enable the TouchPAD. See [“Disabling or enabling the TouchPad”](#) on page 218.

Turning off the computer

It is a good idea to turn off your computer when you are not using it for a while.

If you are using the computer for the first time, leave the computer plugged into a power source (even though the computer is off) to fully charge the main battery. With the computer off, it may take up to three hours to recharge the main battery.

When you power down the computer, you have three options to choose from: Turn Off (or Shut down), Hibernate, and Standby. Each option has its advantages.

- ❖ Use the Shut down command if you are using the Windows XP Professional operating system and are connected to a domain server.
- ❖ If you have work in progress and are not connected to a network, use the Windows Standby or Hibernate commands to save your system settings to memory so that, when you turn on the computer again, you will automatically return to where you left off.
- ❖ To leave the computer off for a longer period, you can use the Windows Turn Off command when not connected to a domain server or the Shut down command when connected to a domain server instead.

CAUTION

Never turn off the computer while any drive is in use. Doing so may damage the media in use and result in loss of data. For more information, see [“Powering down the computer” on page 106](#).

Closing the display panel

When you are finished, shut the computer down and close the display panel to keep dust and dirt out of the computer.

If you close the computer while it is still on, these actions will occur:

- ❖ If you have the LCD power-saver feature set, the LCD panel will automatically turn off until you open it again.
- ❖ If you have the audible warning set, the computer will beep to notify you that it is still on.
- ❖ If you have an action feature set, the computer will perform either: Nothing, Standby, Hibernate, or Turn Off (see [“Enabling Hibernation” on page 173](#)).

Using external display devices

Your computer comes with a built-in LCD display, but you can also connect an external display device to the available video port:

- ❖ An external monitor or projector via the RGB (monitor) port.

Before connecting an external monitor or video projector, configure your computer for the type of device you are connecting. To do this, refer to the documentation for your operating system and devices.

Connecting an external monitor or projector

You can easily attach an external monitor or projector to your computer if you need a larger screen. To do this:

- 1** Connect the monitor’s video cable to the RGB (monitor) port on the left side of the computer.
- 2** Connect the device’s power cable to a live electrical outlet.
- 3** Turn on the external device.

-
- 4 Set the display mode by pressing Fn + F5, or by configuring the Display Properties settings.

Directing the display output when you turn on the computer

Once you have connected an external display device, you can choose to use the internal display only, the external device only, or both simultaneously. The quickest way to change the display output settings is to use the display hot key (Fn + F5):

- 1 Press Fn and F5 simultaneously.
- 2 While holding down Fn, press F5 repeatedly until the setting you want takes effect.

This hot key cycles through the settings in the following order:

- ❖ Built-in display only
 - ❖ Built-in display and external monitor simultaneously
 - ❖ External monitor only
- 3 Release the Fn key.



TECHNICAL NOTE: You can also change these settings using the Display Properties Box.

Set the option for the video controller by clicking Start, then Control Panel and Display. Choose the Settings tab, click the Advanced button, select Display Device, select the applicable Monitor type, and click Apply or OK.

Adjusting the quality of the external display

To obtain the best picture quality from your television (or other video display device), you may need to adjust the video settings. See the video device documentation for additional configuration steps.



TECHNICAL NOTE: To use one of the simultaneous modes, you must set the resolution of the internal display panel to match the resolution of the external display device. The external display device must support a resolution of 640 X 480 or higher.

Using an external keyboard

If you prefer to use a full-size keyboard, you can attach one to your computer. The computer's USB ports support any USB-compatible keyboard.

Using a mouse

You may want to use a mouse instead of the computer's built-in TouchPad. You can use a USB-compatible mouse.

NOTE

After logging on to your system, the mouse cursor may move to the upper-right side of the screen. If this occurs, push the Esc or Windows key to return it to its original position.

Connecting a local printer

CAUTION

Your printer documentation may require you to install the printer software before physically connecting the printer to your computer. If you do not install the software as instructed by the printer manufacturer, the printer may not function correctly.

CAUTION

Never connect the printer cable while the computer's power is on. Doing so may damage the printer, the computer, or both.

NOTE

Read the documentation that came with your printer. Follow the manufacturer's instructions when connecting a local printer.

NOTE

You must supply the proper printer cable. If one did not come with your printer, you may purchase one from an electronics or computer store.

If your printer is ECP- or IEEE-compliant, make sure your printer cable is an IEEE 1284 cable.

You can connect a USB-compatible printer to your computer through the USB ports. To determine if the printer is USB-compatible, check its documentation.

To achieve the connection, you need a suitable USB cable, which may come with your printer. You can purchase one from a computer or electronics store.

To connect a USB printer:



- 1 Plug the USB connector into one of the USB ports on your computer
- 2 Plug the printer's power cable into a live AC outlet.

To connect a parallel printer:

CAUTION

Connecting the parallel printer cable while the computer is on may damage the printer, the computer, or both.



- 1 Connect the printer cable to the printer and to the computer's parallel port.

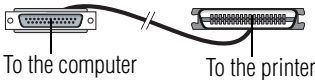

Sample identifying the ends of a parallel printer cable

- 2 Plug the printer's power cable into a live AC outlet.

See your printer documentation for additional configuration steps, or see [“Setting up your printer” on page 133](#).

Connecting an optional external diskette drive

Some operations, such as creating a password service diskette, require a diskette drive designed for use with 3.5-inch diskettes.

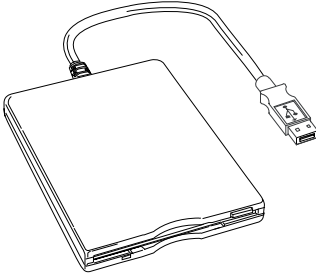

Sample optional external USB diskette drive

To connect an optional external USB diskette drive, connect the cable to one of the computer's USB ports.

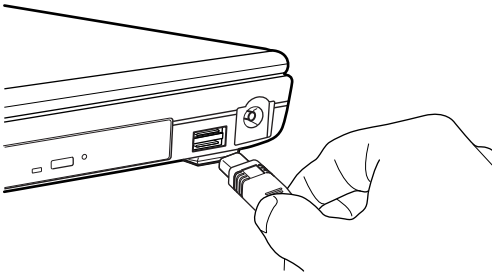

Sample connecting an optional external USB diskette drive

Connecting external speakers or headphones

To attach an external stereo output device:



- 1 Locate the headphone jack near the front of the right side of the computer.
- 2 Using any necessary adapters, plug the cable from the external audio device into the headphone jack. The headphone jack requires a 3.5-mm, 16-ohm stereo jack.

When the headphone is inserted, the internal speakers are automatically disabled.

Connecting a microphone

CAUTION

Before playing an audio CD, turn the volume down. Playing the compact disc at maximum volume could damage your ears. To turn the volume down, use the Volume Control switch or access the Volume Control program (click Start, All Programs, Accessories, Entertainment, Volume Control).

To record high-quality sounds, you can attach a microphone:



- 1 Locate the microphone jack near the front of the right side of the computer.
- 2 Plug the microphone cord into the jack.
- 3 Turn on the microphone.

For more information, see [“Recording sounds” on page 152](#).

Chapter 2

Learning the Basics

This chapter gives some computing tips and provides important information about basic features.

Computing tips

- ❖ Save your work frequently.

Your work stays in the computer's temporary memory until you save it to the disk. If the network you are using goes down and you must restart your computer to reconnect, or your battery runs out of charge while you are working, you will lose all work since you last saved.

See “[Saving your work](#)” on page 93 for further information.



HINT: Some programs have an automatic save feature that can be activated. This feature saves your file to the hard disk at preset intervals. See your software documentation for details.

- ❖ Back up your files to disks (or other removable media) on a regular basis. Label the backup copies clearly and store them in a safe place.

It's easy to put off backing up because it takes time. However, if your hard disk suddenly fails, you will lose all the data on it unless you have a separate backup copy.

- ❖ Use Error-checking and Disk Defragmenter regularly to conserve disk space and improve performance.
- ❖ Scan all new files for viruses.
- ❖ This precaution is especially important for files you receive via diskette, email, or download from the Internet. Take frequent breaks to avoid repetitive-motion injuries and eyestrain.
- ❖ Do not turn off the computer if a drive indicator light indicates a drive is active.

Turning off the computer while it is reading from or writing to a disk may damage the disk, the drive, or both.

- ❖ Before turning off the computer, use the Turn off computer command or Standby command. See

“Powering down the computer” on page 106 to learn more about Standby.

NOTE

The Windows® XP operating system records information, such as your desktop setup, during its shutdown procedure. If you do not let the Windows® XP operating system shut down normally, details such as new icon positions may be lost.

Using the keyboard

Your computer’s keyboard contains character keys, control keys, function keys, and special Windows® keys, providing all the functionality of a full-size keyboard.

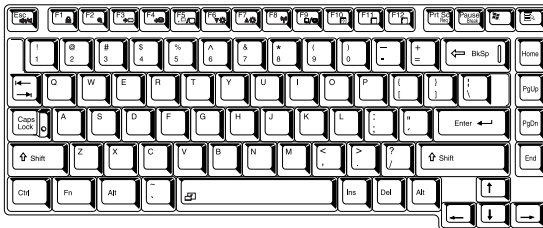

Sample keyboard

Character keys

Typing with the character keys is very much like typing on a typewriter, except that:

- ❖ The space bar creates a space character instead of just passing over an area of the page.
- ❖ The lowercase letter l (el) and the number 1 are not interchangeable.
- ❖ The uppercase letter O and the number 0 are not interchangeable.

Making your keyboard emulate a full-size keyboard

Although your computer's keyboard layout is compatible with a standard full-size keyboard, it has fewer keys.

A standard full-size keyboard has two Enter, Ctrl, and Alt keys; editing keys; cursor positioning keys; and a numeric keypad. Pressing the Fn key simultaneously in combination with one of the specially marked keys allows you to emulate a full-size keyboard.

Your computer's keyboard has only one Enter and one Ctrl key. Most of the time, this does not matter. However, some programs assign separate functions to the right and left Ctrl and Alt keys, or to the regular and numeric pad Enter keys on the full-sized keyboard. Using the Fn key, you can simulate these separate keys, as follows:

- ❖ Press Fn and Ctrl simultaneously to simulate the Ctrl key on the right side of the enhanced keyboard.
- ❖ Press Fn and Enter simultaneously to simulate the Enter key on the numeric pad of the enhanced keyboard.

Ctrl, Fn, and Alt keys



Sample Ctrl, Fn, and Alt keys

The Ctrl, Fn, and Alt keys do different things depending on the program you are using. For more information, see your program documentation.

Function keys

The function keys (not to be confused with the Fn key) are the 12 keys at the top of the keyboard.



Sample function keys

F1 through F12 are called function keys because they execute programmed functions when pressed. Used in combination with the Fn key, function keys marked with icons execute specific functions on the computer. For example, Fn+F9 turns off the TouchPad. For more information, see “Fn-esse®” on page 161, or “Hot Keys” on page 213.

Windows special keys



Sample Windows special keys

Your computer’s keyboard has two keys that have special functions in Windows:

- ❖ **Start key**—Opens the Start menu
- ❖ **Application key**—Has the same function as the secondary mouse button

Overlay keys

The keys with gray numbers and symbols on the front of them form the numeric and cursor overlay. This overlay lets you enter numeric data or control the cursor as you would using the 10-key keypad on a desktop computer’s keyboard.

To disable the numeric overlay, hold down the Fn key and press F11 again. The numeric mode light on the keyboard indicator panel goes out.

Using the overlay for cursor control

The keys with the gray arrows and symbols on their left front are the cursor control overlay keys.



To turn the cursor control overlay on, press Fn and F10 simultaneously. The cursor control mode light on the keyboard indicator panel glows when the cursor control overlay is on.

To type alphabetic characters while the overlay is on:

- ❖ For lowercase letters, hold down Fn while you type the letters.
- ❖ For uppercase letters, hold down both Fn and Shift while you type the letters.

To use the numeric overlay keys while the cursor control overlay is on:

- ❖ Hold down Shift while you use the numeric overlay keys.
- ❖ To return to the cursor control overlay, release Shift.

To disable the cursor control overlay, hold down the Fn key and press F10 again. The cursor control mode light on the keyboard indicator panel goes out.

Starting a program

The easiest way to start a program is to double-click the name of the file that contains the information you want to work on. To find the file, use My Computer or Windows® Explorer.

If you prefer to open the program first, you have four options. You can:

- ❖ Double-click the icon for the program on your desktop
- ❖ Use the Start menu

- ❖ Use Windows® Explorer or My Computer to locate the program file
- ❖ Use the Run dialog box

The next three sections explain how to start a program from the Start menu, Explorer and the Run dialog box.

Starting a program from the Start menu

When you install a program, the operating system usually puts an icon in the All Programs menu. To start a program that has an icon in the All Programs menu, follow these steps, which use the Windows® WordPad program as an example:

- 1** Click **Start**, then point to **All Programs**.

The Windows® XP operating system displays the All Programs menu, which lists programs and program groups. If your program is listed, go to step 3, otherwise, continue with step 2.

- 2** Point to the program group, in this example, **Accessories**.

The Accessories menu is displayed.

- 3** Click the program, in this example, **WordPad**.

WordPad opens.

-  To close the program, click the **Close** button in the upper-right corner of the program's window.

Starting a program from Windows® Explorer

If a program is not listed in the Programs menu, you can start it from Windows® Explorer. Windows® Explorer gives you a view of your computer's contents as a hierarchy or "tree." You can easily see the content of each drive and folder on your computer. To use this method, you should know the file name and location of the program's executable file (this file ends with .exe).

This example opens WordPad using its file name, *wordpad.exe*.

- 1 Click **Start**, then point to **All Programs**.
- 2 Click **Accessories**.
- 3 Click **Windows Explorer**.
- 4 Click **My Computer** to expand the window.
- 5 In the left part of the window, under the C: icon, double-click the folder containing the program, in this case **Program Files**.

Windows® Explorer shows the contents of the Program Files folder on the right side of the window. The left side of the window shows all the folders contained within the Program Files folder.

- 6 In the left part of the window, click **Windows NT**.
- 7 Click **Accessories**.

Windows® Explorer shows the contents of the **Accessories** folder on the right side of the window.

- 8 In the right part of the window, double-click **WordPad**.
The operating system opens WordPad.

 To close the program, click the **Close** button in the upper-right corner of the program's window.

Starting a program from the Run dialog box

This example uses the Run command to start WordPad:

- 1 Click **Start**, then click **Run**.

The Run dialog box appears.

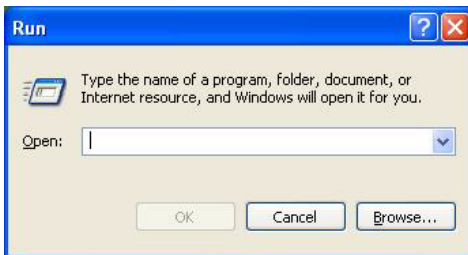

Sample Run dialog box

2 In the Run dialog box:

- ❖ If you know the program's location, type the command line. For a program in the Windows[®] folder, type just the program name. Otherwise, type the full file path. For example, to access WordPad, type: `c:\Program Files\WindowsNT\Accessories\Wordpad`, then click **OK**.
- ❖ If you do not know the location, click **Browse....** In the Browse dialog box, enter the file name (for example, *wordpad.exe*) and select the drive to search. When the operating system has found the file, click **Open**.



HINT: To run the same program again, click the arrow to the right of the text box and select the command line from the drop-down list.

Saving your work

Before you turn off the computer, save your work on the hard disk drive or diskette/CD. This is one of the most important rules of computing.



TECHNICAL NOTE: Save your data even when you are using the Standby command, in case the main battery discharges before you return to work.

Saving documents is quick and easy, so it is a good idea to get in the habit of saving frequently.

Many programs offer a feature that saves documents at regular intervals. Check your program's documentation to see if it has an automatic save feature.

Saving files

- 1 On the **File** menu of your Windows® program, click **Save**.

If you are working with a document that already has a file name, this is all you need to do. If you created a new document, your program displays a Save As dialog box.

Use this dialog box to specify where to store the document and to give it a file name.

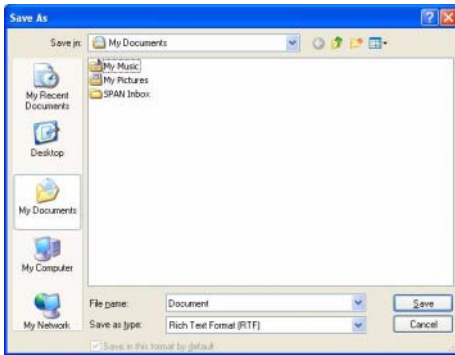

Sample Save As dialog box

- 2 Choose the drive and folder where you want your file to be stored.
- 3 Type a file name, then click **Save**.



HINT: To make another copy of the file you are currently working with, choose Save As from the File menu and give the new file a different name.

The Windows® XP operating system supports file names of up to 255 characters; the names can include spaces. Some applications still require MS-DOS® file names.

File names

If you plan to share your files with a computer using a pre-Windows® 95 version of the Windows® operating system, the file name must be no more than eight characters long. Typically the file name also has an extension, consisting of a period and up to three additional characters.

You may use all the letters and numbers on the keyboard plus these characters: _ ^ \$ ~ ! # % & { } () @ and ' . MS-DOS® file names are not case-sensitive and must not contain spaces.

Using a file extension

Most programs assign an extension to the file name that identifies the file as being created in the program with a particular format. For example, Microsoft® Word saves files with a .doc extension. Any file name with an extension of “.doc” is assumed to be a Microsoft® Word file. Creating your own extension is usually unwise, since the program is unlikely to recognize a strange extension and may refuse to handle your file correctly.

Printing your work

Ensure the operating system is set up for your printer as described in [“Using a printer”](#) on page 132.



HINT: You only need to set up the printer the first time you connect it. If you use more than one printer or are changing printers, you will need to set up the Windows® XP Professional operating system to run with the additional printer(s).

To print a file:

- 1** If your printer is not on, turn it on now.
- 2** Open the **File** menu of your Windows® program and click **Print**.

The program displays a Print dialog box.

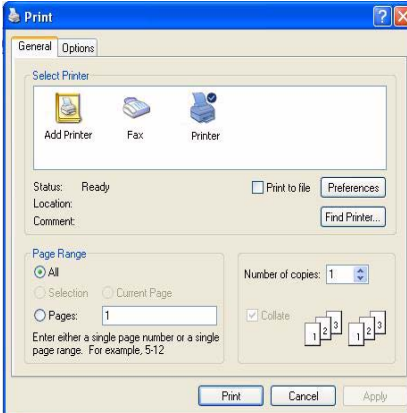

Sample Print dialog box

- 3 Specify the print parameters. For example, the range of pages and number of copies to print.
- 4 Click **Print**.

Using the DVD-ROM or multi-function drive

Optical storage has become the preferred medium for software, music, and video. Digital versatile discs (DVDs) provide a significant increase in data storage and support features that are not available on any other video platform. These features include wide-screen movies, multiple language tracks, digital surround sound, multiple camera angles, and interactive menus.

For these reasons, your computer may come with a DVD-ROM drive or multi-function drive.



TECHNICAL NOTE: Your DVD-ROM or multi-function drive is set to play region 1 (North America) DVD-ROMs. If you play a DVD disc from another region, the drive will automatically change to play in the format of the other region. The drive will allow you to change regions four times. On the fourth change, the region will be “locked in.” That is, the drive will only play DVDs from that last region. Note that changing from region 1 to region 2 and back to region 1 is counted as two changes.

NOTE

For optimum CD and DVD performance, it is recommended that you play CDs and DVDs while running the computer on AC power.

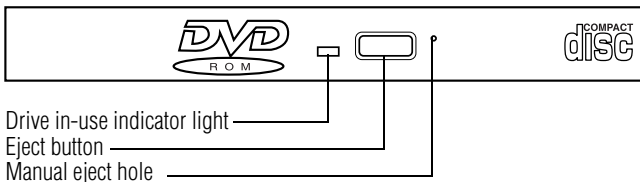
**Sample DVD-ROM drive**

Drive in-use indicator light—Indicates when the drive is in use.

Eject button—Press to release the disc tray.

CAUTION

Do not press the eject button or turn off the computer while the Drive in-use indicator light is glowing. Doing so could damage the disc or the drive.

When the disc tray is open, be careful not to touch the lens or the area around it. Doing so could cause the drive to malfunction.

Manual eject hole—Use if you need to release the disc tray when the power is off. Use a straightened paper clip or other narrow object to press the manual eject button located inside the hole.

CAUTION

Never use a pencil to press the eject button. Pencil lead can break off inside the computer and damage it.

Inserting a compact disc

To insert a compact disc into the drive:

- 1 Make sure the computer is turned on.
- 2 Make sure the in-use indicator light is off.
- 3 Press the drive's eject button.

The disc tray slides partially out of the drive (about 1 inch).

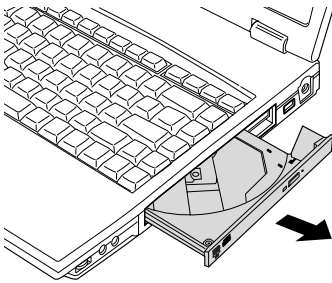

Sample drive tray partially extended



HINT: The drive will not open if the computer's power is off.

- 4 Grasp the tray and pull it fully open.
- 5 Hold the disc by its edges and check that it is free of dust.

If the disc is dusty, clean it as described in “Caring for CD or DVD Discs” on page 100.

- 6 Place the disc carefully in the disc tray, label side up.

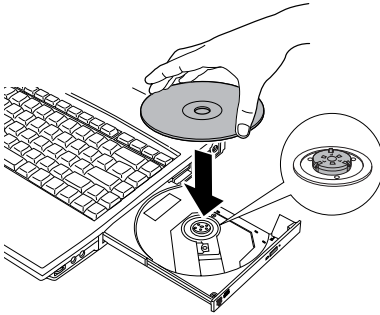

Sample positioning the disc in the drive

- 7 Gently press the disc onto the center spindle until you feel it click into place.

CAUTION

Handle DVDs and CDs carefully, making contact only with the center hole and edge. Do not touch the surface of the disc. Do not stack discs. If you incorrectly handle the discs, you could lose data.

- 8 Make sure the disc is completely on the spindle and is lying flat on the tray.

CAUTION

If you insert the disc incorrectly, it may jam the drive. If this happens, contact Toshiba support for assistance.

- 9 Push the disc tray in by pressing gently on the center of the tray until it clicks into place.

You are ready to use the disc.

Removing a disc with the computer on

To remove a compact disc (CD or DVD) with the computer turned on:

- 1 Press the eject button on the drive.
-

CAUTION

Do not press the eject button while the in-use indicator light is glowing. Doing so could damage the disc or the drive.

Also, if the disc is still spinning when you open the disc tray, wait for it to stop spinning before you remove it.

- 2 Pull the tray until it is fully open, remove the disc, and place it in its protective cover.
- 3 Gently push the tray in to close it.

Removing a disc with the computer off

- 1 Insert a slender object, such as a straightened paper clip, into the manual eject hole.
- 2 Gently pull the tray out until it is fully open, remove the disc, and place it in its protective cover.
- 3 Gently push the tray in to close it.

Caring for CD or DVD Discs

- ❖ Store your discs in their original containers to protect them from scratches and keep them clean.
- ❖ Do not bend a disc or place heavy objects on top of it.
- ❖ Do not apply a label to or otherwise mar the surface of a disc.
- ❖ Hold a disc by its outside edge. Fingerprints on the surface can prevent the DVD-ROM drive or multi-function drive from reading the data properly.

-
- ❖ Do not expose discs to direct sunlight or extreme heat or cold.
 - ❖ To clean a disc that is dirty, wipe it with a clean, dry cloth. The most efficient method to clean it is to start from the center of the disc and wipe toward the outward edge (not in a circle). If necessary, moisten the cloth with water or a neutral cleaner (not benzine or rubbing alcohol). Let the disc dry completely before inserting it in the drive.

Using PC Cards



TECHNICAL NOTE: For PCMCIA-compatible PC Cards, check the package to make sure they conform to the PCMCIA 2.1 standard (or later). Other cards may work with your computer, but are likely to be much more difficult to set up and use.

For information on inserting or removing a PC Card, see [“Inserting and removing PC Cards” on page 156.](#)

Hot swapping

With PC Cards, you can replace one PC Card with another while the computer is on. This is called “hot swapping.”

Hot swapping precautions

Although you can insert a PC Card at any time, remember not to remove a card while it is in use. Otherwise, you could lose valuable information. For example:

- ❖ Do not remove a hard disk card while the system is accessing it.
- ❖ Do not remove a network card while you are connected to a network.

- ❖ Do not remove a SCSI card while any of the SCSI devices connected to it are operating.

Before removing a PC Card, stop it by clicking the **Safely Remove Hardware** icon on the System tray. After the PC Card is stopped, it is safe to remove.

Using your computer at the office

By connecting an external monitor, external full-size keyboard, and a mouse, you can work with your notebook as if it were a standard office computer.



An external monitor or projector connects to the RGB (monitor) port.



Any USB device can connect to the USB ports.

Using a computer lock

For your own peace of mind, you may want to secure your computer to a heavy object such as your desk. The easiest way to do this is to purchase an optional PORT-Noteworthy[®] Computer Lock Cable.

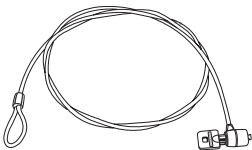

Sample PORT-Noteworthy[®] Computer Lock Cable

To secure the computer:

- 1 Loop the cable through or around some part of a heavy object.

Make sure there is no way for a potential thief to slip the cable off the object.

- 2 Pass the locking end through the loop.

-
-  **3** Insert the cable's locking end into the security lock slot on the left side of the computer, then give the key a quarter turn and remove it.

The computer is now securely locked.

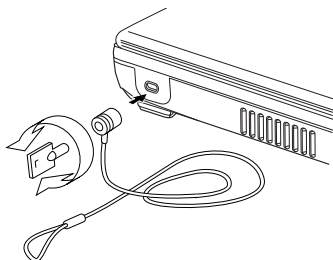

Sample locking the computer

Caring for your computer

This section gives tips on cleaning and moving your computer. For information about taking care of your computer's battery, see [“Running the computer on battery power”](#) on page 115.

Cleaning the computer

CAUTION

Keep liquids, including cleaning fluid, out of the computer's keyboard, speaker, and other openings. Never spray cleaner directly onto the computer. Never use harsh or caustic chemical products to clean the computer.

To keep your computer clean, gently wipe the display panel and exterior case with a lightly dampened cloth. Ask your Toshiba dealer for suggestions for appropriate cleaning products.

Moving the computer

Before moving your computer, even across the room, make sure all disk activity has ended (the drive indicator light stops glowing) and all external peripheral cables are disconnected.

CAUTION

Do not pick up the computer by its display panel or by the back (where the ports are located).

Although your notebook computer is built to withstand reasonable shock and vibration, transport it in a carrying case for long trips. You can purchase a carrying case from your Toshiba dealer, through the accessories information packaged with your system, or visit accessories.toshiba.com.

Backing up your work

Your computer comes with Hard Disk Drive Recovery Utilities that enable you to reinstall software that was preinstalled. This can be used to install or reinstall particular Toshiba applications, utilities, and drivers. For more information, see “[Hard Drive Recovery Utilities](#)” on page 62. Back up all the files you create in case something happens to your computer. If you have a network partition, you can hold copies of your files there.

Alternatively, you can back up your files to diskette one at a time as you are working on them.

To back up several files at one time, use the Microsoft® Windows® backup program preinstalled on the computer’s hard disk.

Complete information on the backup program is in the online Help and your Windows® documentation.



HINT: Backing up all the files on your hard disk takes a considerable amount of time and many diskettes. You may prefer to use a high-capacity backup system, such as an external tape drive.

Restoring your work

To restore information from your backup media to your hard disk, use the Restore page in the backup program. Look in the online Help or your operating system documentation for information on restoring files.



TECHNICAL NOTE: When restoring files, the backup program prompts you if you try to overwrite a file that already exists on the hard disk. Make sure the backup version is the one you want before overwriting the existing file.

Preparing for communications

To connect to the Internet, use an online service, or communicate across the telephone lines with another computer, you need:

- ❖ A modem (supplied with your computer)
- ❖ A telephone line
- ❖ A browser or communications program
- ❖ An Internet Service Provider (ISP) or an online service if you plan to use the Internet

Before you can use the modem, you must connect it to a standard voice-grade telephone line. See [“Connecting to a power source” on page 49](#) for details.

Powering down the computer

NOTE

Pushing the power button before shutting down the Windows operating system could cause you to lose your work. Make sure the system indicator panel's disk light and the drive-in use light are off. If you turn off the power while a disk is being accessed, you may lose data or damage the disk and/or drive.

When you power down the computer, you have three options to choose from: Turn Off Computer, Standby, and Hibernation.



TECHNICAL NOTE: Before using any of these options to power down your computer, save your files and make sure the disk activity lights are off.

If you change your mind and decide to continue working after all, wait a few seconds before turning the computer on again.

Using Turn Off Computer or Shut Down

For the Windows XP Professional operating system, follow these steps to shut down the computer:

- 1 Click **Start**, select **Turn off computer**.

The Turn off computer dialog box appears.



Sample Turn off computer Windows dialog box

2 Click **Turn Off**.

The computer shuts down completely.

For the Windows XP Professional operating system, follow these steps to shut down the computer:

1 Click the **Start** button, then **Shut down**.

The Shut Down Windows dialog box appears.

2 Select **Shut down** from the drop-down list.**3** Click **OK**.

The computer shuts down completely.

NOTE

Holding the Shift key while the Turn Off computer Windows dialog box is open, changes the Stand By button to hibernate. For more information about setting up hibernation, refer to [“Using Hibernation” on page 109](#).

Shutting down more quickly

You can shut down the computer by pressing the power button.

To use either of these methods, you first need to turn it on in Toshiba’s Power Saver utility.

1 Open the **Start** menu, click **Control Panel**, then **Performance and Maintenance**.**2** Click the **Toshiba Power Saver** icon.**3** Click on the **Setup Action** tab.**4** Select the options you want from the drop-down lists.❖ **When I press the power button**

Set this option to **Shutdown** to have the computer shut down when you press the power button.

- 5 Click **Apply**.
- 6 Click **OK**.

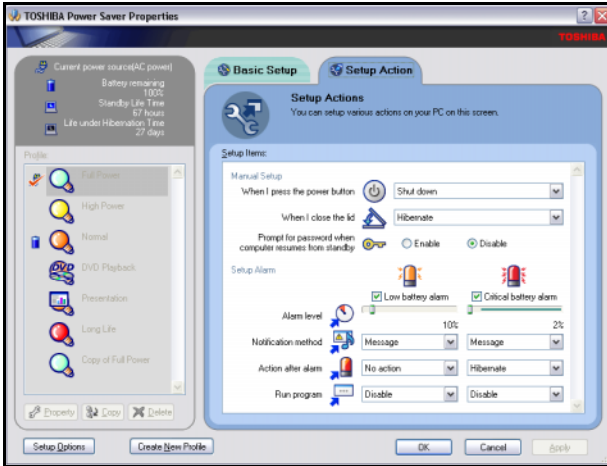

Sample system power mode settings

NOTE

For more information about the Power Saver utility, see “TOSHIBA Power Saver” on page 166.

Starting again after Shut down

To start the computer up again, press the power button until the on/off light changes to green.

If you shut down the computer by closing the display panel, you can start it again by opening the display panel.

Using Hibernation

Hibernation mode shuts the computer down completely, but it first saves the current mode of the computer to the hard disk. Since Hibernation mode does not require power to maintain the saved information, the system settings are retained indefinitely. Restoring information from the hard disk takes longer than restoring it from memory. When you start up again, the computer runs a self-test, loads the operating system, and then returns to the mode in which you left it.

Factors to consider when choosing Hibernation:

- ❖ While in Hibernation mode, the computer uses no battery power
- ❖ Because the mode of the system is held on the hard disk, no data is lost if the main battery discharges
- ❖ When starting up again, Hibernation uses less time and battery power than does Turn off computer
- ❖ Restarting from Hibernation uses a little more time and battery power to start up than restarting from Standby, because information is being retrieved from the hard disk rather than from memory
- ❖ When starting up again, the computer returns to the mode in which you left it, including all open programs and files you were using

Configuring your computer for Hibernation

- 1 Open the **Start** menu, click **Control Panel**, then **Performance and Maintenance**.
- 2 Click the **Toshiba Power Saver** icon.
- 3 Click the **Setup Action** tab.
- 4 Select **Hibernation** for the options you want.



- ❖ **When I press the power button**
Set this option to **Hibernate** so that the computer

will go into Hibernation mode when you press the power button.

❖ **When I close the lid**

Set this option to **Hibernate** so that the computer will go into Hibernation mode when you close the display panel.

5 Click **Apply**.

6 Click **OK**.

The computer is now set to automatically go into Hibernation when your option settings occur.

NOTE

For more information about the Power Saver utility, see [“TOSHIBA Power Saver” on page 166](#).

Once the computer is configured, put the computer into Hibernation mode by either pressing the power button or closing the display panel, depending on the hibernation options taken.

Starting again from Hibernation mode

To start up the computer from Hibernation mode, press the power button until the on/off light turns green. The computer returns to the screen you were using.

If you put the computer in Hibernation mode by closing the display panel, you can start it again by opening the display panel.

Using Standby

The Standby command puts the computer into a power-saving mode. Standby holds the current mode of the computer in memory so that, when you restart the computer, you can continue working from where you left off.

Factors to consider when choosing Standby:

- ❖ While in Standby mode, the computer uses some battery power. A fully charged main battery will last up to eight hours in Standby mode.
- ❖ Restarting from Standby uses less time and battery power than restarting from Turn off computer or Hibernation.
- ❖ When starting up again, the computer returns to the mode in which you left it, including all open programs and files you were using.

NOTE

If you power down using the Standby command and the main battery discharges fully, your information will be lost. Be sure to save your work first.

To power down the computer using the Standby command, click **Start**, **Turn off computer**, and select **Stand By**.



Sample Turn off computer Windows® dialog box

NOTE

If you hold down the Shift key, Stand By becomes Hibernate in the Turn off computer dialog box. To enter hibernation mode, you must hold down the Shift key while you select Hibernate.

The computer saves the status of all open programs and files, turns off the display, and goes into a low-power mode. The on/off light blinks amber indicating the machine is in Standby mode.

Going into Standby mode more quickly

You can put the computer into Standby mode by either pressing the power button or closing the display panel. You can also specify an amount of time after which the computer automatically goes into Standby mode.

To use any of these methods, you first need to enable them in Toshiba's Power Saver utility.

- 1 Open the **Start** menu, click **Control Panel**, then **Performance and Maintenance**.
- 2 Click the **Toshiba Power Saver** icon.
- 3 Click the **Setup Action** tab.
- 4 Select **Standby** for the options you want.
 - ❖ **When I press the power button**
Set this option to **Standby** to put the computer into Standby mode when you press the power button.
 - ❖ **When I close the lid**
Set this option to **Standby** to put the computer into Standby mode when you close the display panel.
- 5 Click **Apply**.

6 Click **OK**.

NOTE For more information about the Power Saver utility, see [“TOSHIBA Power Saver” on page 166](#).

Starting again from Standby mode

To start up the computer from Standby mode, press the power button until the on/off light changes to green. The computer returns to the screen you were using.

If you put the computer in Standby mode by closing the display panel, you can start it again by opening the display panel.

Toshiba's online resources

Toshiba maintains a number of online sites to which you can connect. These sites provide information about Toshiba products, give help with technical questions and keep you up to date with future upgrades. For more information, see [“Contacting Toshiba” on page 210](#).

Chapter 3

Mobile Computing

This chapter covers all aspects of using your computer while traveling.

Toshiba's energy-saver design

Your computer enters a low-power standby mode when it is not being used, thereby conserving energy and saving money in the process. It has a number of other features that enhance its energy efficiency.

Many of these energy-saving features have been set by Toshiba. We recommend you leave these features active, allowing your computer to operate at its maximum energy efficiency, so that you can use it for longer periods while traveling.

Running the computer on battery power



The computer contains a removable Lithium-Ion (Li-ion) battery pack that provides power when you are away from an AC outlet. This is the main battery. You can recharge it many times.

Battery Notice

Battery life may vary, depending on applications, power management settings, and features utilized. Recharge time varies depending on usage. The battery may not charge while the computer is consuming full power.

After a period of time, the battery will lose its ability to perform at maximum capacity and will need to be replaced. This is normal for all batteries. To purchase a new battery pack, see your accessories information that shipped with your computer, or to stay current on the most recent software and hardware options for your computer, and for other product information, regularly check the Toshiba Web site at accessories.toshiba.com.

To ensure that the battery maintains its maximum capacity, operate the computer on battery power at least once a month until the battery is fully discharged. Please see “[Charging the batteries](#)” on [page 116](#) for procedures. If the computer is continuously operated on AC power, either through an AC adapter or docking station for an extended period, more than a month, the battery may fail to retain a charge. It may not function efficiently over the expected life of the battery and the battery light may not indicate a low-battery condition.

NOTE

For optimum DVD performance, Toshiba recommends that you play DVDs while running on AC power rather than on battery power.

NOTE

Over a period of time, and depending on the usage of the computer, the brightness of the LCD Screen will deteriorate. This is an intrinsic characteristic of LCD technology.

Screen will dim when the computer is operated on battery power and you may not be able to increase the brightness of the screen.

Charging the batteries

NOTE

Battery charge time may vary depending on the applications, power management settings, and features used.

The battery needs to be charged before you can use it to power the computer.

CAUTION

Never leave batteries in the battery charger for more than a week at a time. Doing so may reduce the potential charge of the battery.

Use only battery chargers designed to work with your notebook computer. You can order a Toshiba battery charger from Toshiba's Web site at accessories.toshiba.com.

Charging the main battery

To charge the battery, plug the computer into a live wall outlet. It takes several hours to charge the battery with the computer off. It takes much longer to charge the battery while the computer is on.



TECHNICAL NOTE: The battery does not charge while the computer is consuming full power.

The battery may not start charging immediately if:

- ❖ The battery is extremely hot or cold.

To ensure that the battery charges to its full capacity, wait until it reaches room temperature (50 to 80 degrees Fahrenheit, 10 to 26 degrees Celsius).

- ❖ The battery is almost completely discharged.

Leave the power connected, and the battery should begin charging after a few minutes.



HINT: Once the battery is fully charged, we recommend that you operate your computer on battery power until the battery discharges completely. Doing this extends battery life and helps ensure accurate monitoring of battery capacity.

Charging the RTC battery

Your computer has an internal real-time clock (RTC) battery. The RTC battery powers the System Time Clock and BIOS memory used to store your computer's configuration settings. When fully charged, it maintains this information for up to a month when the computer is powered off.

The RTC battery may have become completely discharged while your computer was shipped, resulting in the following error message during startup:

```
BAD RTC BATTERY  
BAD CHECKSUM (CMOS)  
CHECK SYSTEM
```

NOTE The above error message may vary by computer model. The RTC battery does not charge while the computer is turned off even when the AC adapter is charging the computer.

If the RTC battery is low, the real-time clock and calendar may display the incorrect time and date, or stop working.

NOTE It is seldom necessary to charge the RTC battery because it charges while the computer is on. If the RTC battery is low, the real-time clock and calendar may display the incorrect time and date or stop working.

When Hibernation mode is enabled and the RTC battery is completely discharged, a warning prompts you to reset the real-time clock.

The computer can be used while the RTC battery is being charged, although the charging status of the RTC battery cannot be monitored.

Monitoring battery power

The computer's main battery light gives you an indication of the main battery's current charge:

- ❖ Green indicates the AC adapter has fully charged the battery.
- ❖ Amber indicates the AC adapter is charging the battery.
- ❖ Off indicates that the battery is not being charged.

NOTE

Battery life and charge time may vary, depending upon power management settings, applications and features used.

- ❖ Flashing amber indicates that the computer is using battery power, and the battery's charge is running low.



HINT: Be careful not to confuse the battery light (☐) with the on/off light (⏻). When the on/off light flashes amber, it indicates that the system is suspended (using Windows® XP Standby command).

Displaying remaining battery power

You can monitor the battery's remaining charge. The computer calculates the remaining battery charge as it operates, based on your current rate of power use.

To show remaining power:

- 1 Open the **Start** menu, click **Control Panel**, then **Performance and Maintenance**.
- 2 Click the **Toshiba Power Saver** icon.



The Toshiba Power Saver Properties dialog box appears.

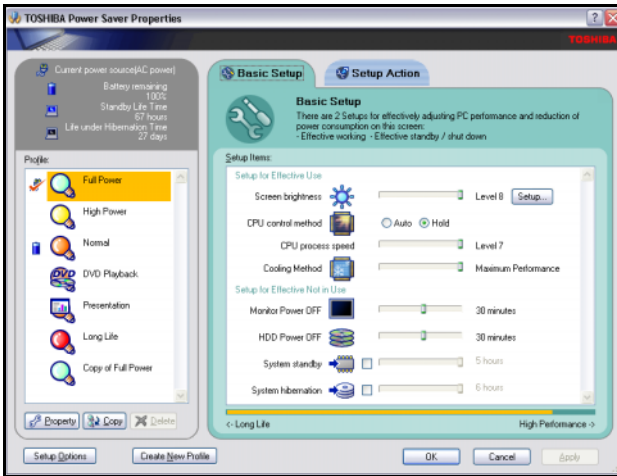

Sample Toshiba Power Saver Properties Dialog Box

The remaining battery charge is indicated on the top-left side of the dialog box.

With repeated discharges and recharges, the battery's capacity gradually decreases. A frequently used older battery will not power the computer for as long as a new battery, even when both are fully charged.



HINT: Wait at least 16 seconds after turning on the computer before trying to monitor the remaining battery power. The computer needs this time to check the battery's remaining capacity and perform its calculations.



The computer drains battery power more quickly at low temperatures. Check your remaining charge frequently if you are working in temperatures below 50 degrees Fahrenheit.

The Windows® operating system has additional power management options that can be accessed through an icon in the Control Panel. For more information, see “[TOSHIBA Power Saver](#)” on page 166.

What to do when the battery alarm sounds

Your Tecra® A2 Series computer can be configured to warn you of a low battery charge condition, so you can take the necessary steps to save your work.

Your Windows® operating system offers two alarms before your system shuts down.

To change the default alarm settings:

- 1 Open the **Start** menu, click **Control Panel**, then **Performance and Maintenance**.
- 2 Click the **Toshiba Power Saver** icon.
- 3 Click the **Setup Action** tab.
- 4 Select the **Alarm** settings in the Setup Alarm section.

Before your computer runs out of battery power, save your data and take one of the following actions:

- ❖ Suspend or shut down your computer.
- ❖ Shut down your computer and replace the main battery with a charged one.
- ❖ Connect your computer to an AC power source.

Changing batteries

CAUTION

When handling battery packs, do not drop or knock them. Also, be careful not to damage the casing or short-circuit the terminals.

To change the battery:

- 1 Save your work.
- 2 Shut down and turn off the computer.
- 3 Remove all cables connected to the computer.
- 4 Turn the computer over.
- 5 If the battery release lock is in the locked position, slide it toward the unlocked position.

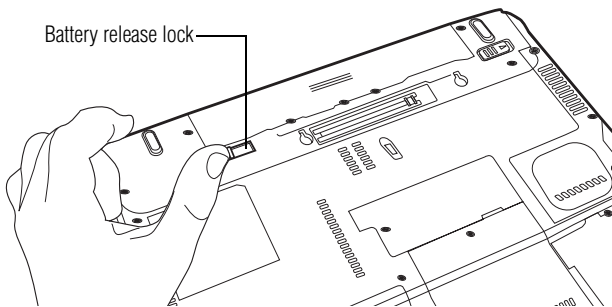

Sample battery release lock

-
- 6 Press the battery release latch to release the battery.

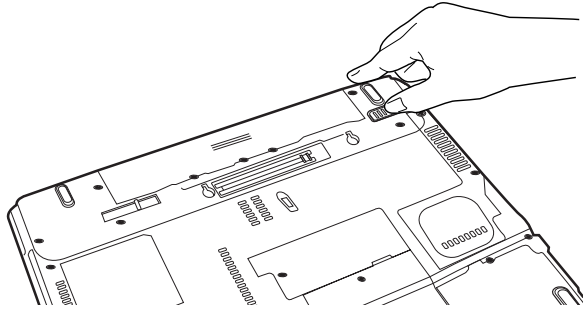

Sample battery release latch

- 7 Pull the discharged battery out from the back of the computer.

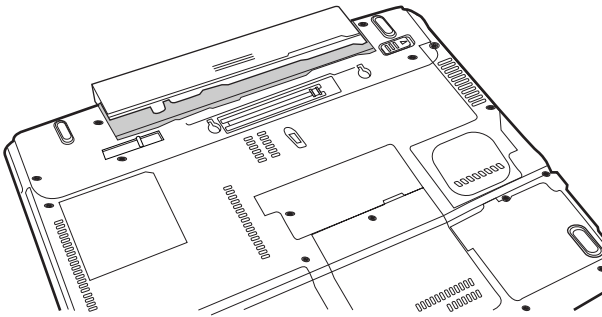

Sample removing the discharged battery

⚠ WARNING

If the battery is leaking or its case is cracked, put on protective gloves to handle it, and discard it immediately following the advice in [“Disposing of used batteries”](#) on page 127.

-
- 8 Wipe the terminals of the charged battery with a clean cloth to ensure a good connection.

- 9 Insert the charged battery into the slot until the latch clicks.

The battery pack has been designed so that you cannot install it with reverse polarity.

CAUTION

If the battery does not slide into the slot easily, move the battery release lock to the unlocked position and try again. Do not force the battery into position.

- 10 Reset the battery release lock to the locked position.
- 11 Turn the computer right side up.
- 12 Reconnect any cables.
- 13 Restart the computer.

Taking care of your battery

The following sections offer tips on how to take care of your battery and prolong its life.

Safety precautions

- ❖ If the battery pack produces an odor, overheats, or changes color or shape while it is being used or charged, turn off the computer's power immediately and disconnect the power cord from the power socket. Carefully remove the battery pack from the computer.
- ❖ Do not try to disassemble a battery pack.
- ❖ Do not overcharge or reverse charge a battery. Overcharging will shorten its life, and reverse charging could damage it.
- ❖ Avoid touching the metal terminals of the battery with another metal object. Short-circuiting the battery can cause it to overheat and may cause damage to the battery or the computer.

-
- ❖ Do not incinerate a spent battery, as this could cause it to explode and release toxic materials.
 - ❖ If a battery is leaking or damaged, replace it immediately. Use protective gloves when handling a damaged battery.
 - ❖ To replace the main battery, use an identical battery that you can purchase through to Toshiba Web site at accessories.toshiba.com.
 - ❖ A reverse polarity condition should be avoided with all batteries. The main battery is designed so that it cannot be installed in reverse polarity.
 - ❖ Charge the battery only in the computer or in a battery charger designated as an approved option.
 - ❖ When you install the battery pack, you should hear a click when it is seated properly.
 - ❖ Do not expose the battery pack to fire. The battery pack could explode.

Maximizing battery life

To maximize the life of your battery pack:

- ❖ At least once a month, disconnect the computer from a power source and operate it on battery power until the battery pack fully discharges. Before doing so, follow the steps below:
 - 1 Turn off the computer's power.
 - 2 Disconnect the AC adapter and turn on the computer's power. If it does not turn on, go to step 4.

- 3 Operate the computer on battery power for five minutes. If the battery pack has at least five minutes of operating time, continue operating until the battery pack is fully discharged. If the battery light flashes or there is some other warning to indicate a low battery, go to step 4.
 - 4 Connect the AC adapter to the computer and the power cord to a power outlet. The DC-IN or AC power-light should glow green, and the battery should glow amber to indicate that the battery pack is being charged. If the DC-IN or AC power-light indicator does not glow, power is not being supplied. Check the connections for the AC adapter and power cord.
 - 5 Charge the battery pack until the battery light glows green.
- ❖ If you have extra battery packs, rotate their use.
 - ❖ If you will not be using the system for an extended period, more than one month, remove the battery pack.
 - ❖ Disconnect the AC adapter when the battery is fully charged. Overcharging makes the battery hot and shortens life.
 - ❖ If you are not going to use the computer for more than eight hours, disconnect the AC adapter.
 - ❖ Store spare battery packs in a cool dry place out of direct sunlight.

Disposing of used batteries

The life of a battery pack should last for years. When the battery pack needs replacing, the main battery light flashes amber shortly after you have fully recharged the battery.

You must discard a battery if it becomes damaged.

⚠ WARNING

The computer's main battery is a Lithium-Ion (Li-Ion) battery, which can explode if not properly replaced, used, handled, or disposed of. Putting spent batteries in the trash is not only irresponsible, it may be illegal. Dispose of the battery as required by local ordinances or regulations.

Use only batteries recommended by Toshiba.

After repeated use, the batteries will finally lose their ability to hold a charge and you will need to replace them. Under federal, state and local laws, it may be illegal to dispose of old batteries by placing them in the trash.

Please be kind to our shared environment. Check with your local government authority for details regarding where to recycle old batteries or how to dispose of them properly. If you cannot find the information you need elsewhere, call Toshiba at: (800) 457-7777.

Conserving power

How long a fully charged battery pack lasts when you are using the computer depends on a number of factors, such as:

- ❖ How the computer is configured.
- ❖ How much you use the hard disk, DVD-ROM or multi-function drive, diskette drives, or other optional devices.
- ❖ Where you are working, since operating time decreases at low temperatures.

There are various ways in which you can conserve power and extend the operating time of your battery:

- ❖ Enable Standby or Hibernation, which saves power when you turn off the computer and turn it back on again.
- ❖ Use Toshiba's power-saving options.

These power-saving options control the way in which the computer is configured. By using them, you can greatly increase the length of time you can use the computer before you need to recharge the battery.

Toshiba has combined these options into preset power profiles. Using one of these profiles lets you choose between maximum power savings and peak system performance. You may also set individual power-saving options to suit your own needs.

The following sections describe how to choose a power profile and discuss each power-saving option.

Power profiles in Windows XP

In Windows® XP, you can choose from predefined power profile or select your own combination of power management options. To do this:

- 1 Open the **Start** menu, click **Control Panel**, then **Performance and Maintenance**.
- 2 Click on the **Toshiba Power Saver** icon.
- 3 Select an appropriate profile for your work environment, or create your own custom profile.
- 4 For more information, see [“TOSHIBA Power Saver” on page 166](#).

Using a hot key to set the power profile

You may use a hot key to set the power profile.

To set the power profile:

- 1 Press Fn and F2 simultaneously to display the power profile pop-up window.

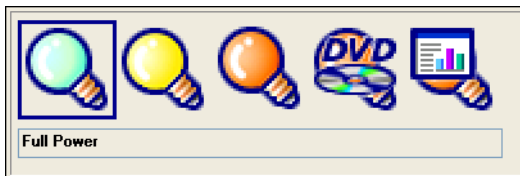

Sample Power Profile mode pop-up window

- 2 While continuing to press Fn, press F2 until you select the desired power profile.

The power profile options are: Full Power, High Power, Normal, DVD Playback, Presentation, and Long Life.

- 3 Release the Fn key.

The pop-up window disappears. You are now in the selected mode.

For more information on setting the battery power profile, see “TOSHIBA Power Saver” on page 166.

Additional options for power

Depending on the amount of time you spend away from external power sources, the capacity of one battery pack may be sufficient for your needs. However, if you need more portable power, Toshiba provides these options:

- ❖ Purchase extra battery packs.
- ❖ Purchase a battery charger that charges one main battery pack and one secondary battery pack at a time.

Chapter 4

Expansion Options

Your computer is designed to work in the office as well as on the road. This chapter explains how to set up the various optional devices so that your notebook can provide all the convenience of a traditional desktop computer.

Devices for office computing

By connecting optional devices such as an external monitor, a full-size keyboard and a mouse, you can work with your notebook as if it were a standard office computer.

You can connect any of these optional devices:

- ❖ Expansion memory modules
- ❖ Standard 101-key keyboard
- ❖ Mouse or trackball
- ❖ Printer
- ❖ PC Cards
- ❖ Toshiba Advanced Port Replicator III

Some of these devices listed are Toshiba devices, others are standard computer components.

The devices manufactured by Toshiba can be purchased through Toshiba's Web site: accessories.toshiba.com, or through the accessories information packaged with your computer.

Using an external keyboard

If you prefer to use a full-size keyboard, you can attach one to your computer. The computer's USB ports supports any USB-compatible keyboard.

Using a mouse

If you prefer, you can use a mouse instead of the computer's built-in pointing device — the TouchPad. You can use a USB-compatible mouse.



TECHNICAL NOTE: With a USB mouse, you can choose to have the TouchPad active at the same time.

Connecting a USB mouse

To connect a USB mouse, connect the mouse cable to the USB port on the computer. Once connected, the mouse is ready to use.

Using a printer

Before you can connect a printer, you must determine whether it requires a parallel or USB interface. Check the printer's documentation.

You also need a suitable printer cable, which may have been provided with your printer. If not, your company may keep a stock of cables. Otherwise, you can purchase one from a computer or electronics store.

Setting up your printer

Setting up a printer involves selecting a printer driver. This special program acts as a translator that turns your document into a form the printer can understand.

If you are using any non-Windows® programs, set up a printer driver for each of those programs. Refer to your program's documentation for more information.



TECHNICAL NOTE: If you have the manufacturer's disk that came with your printer, you can use it to install the printer on your computer. The manufacturer's disk may include additional drivers and fonts.

To set up a printer with the Add Printer Wizard:

- 1 Click **Start**, and click **Printers and Faxes**.

The operating system opens a Printers and Faxes window.

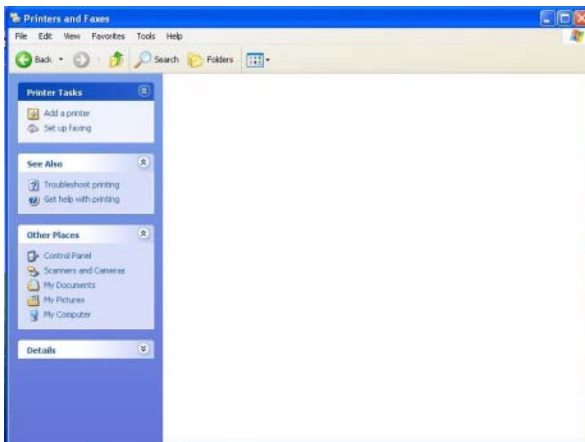

Sample Printers and Faxes window

- 2 Click **Add Printer**.

The Add Printer Wizard appears.



Sample Add Printer Wizard dialog box

3 Click **Next**.

The Add Printer Wizard asks you to select your printer.



TECHNICAL NOTE: If your printer is Plug and Play, the Windows® XP operating system recognizes it automatically. You can ignore the remainder of this section. See your printer manual.

4 If the printer you are setting up:

- ❖ Is not connected to a network, select **Local printer attached to this computer**.
- ❖ Is connected to a network, select **Network printer, or a printer attached to another computer**.

5 Click **Next**.

The Add Printer Wizard looks for a Plug and Play printer. If it does not locate one, click **Next**.

The Add Printer Wizard prompts you for the printer port.

-
- 6** Select the port settings according to the instructions in your printer's documentation and the port to which your printer is connected, then click **Next**.

The wizard prompts you to select your printer.

- 7** From the list of manufacturers and printers, select your printer, then click **Next**.

The Add Printer Wizard prompts you to enter a "friendly" printer name.

- 8** Enter a name for your printer.



HINT: If you are using more than one printer, make sure the name is descriptive enough to help you tell the difference.

- 9** If you want this printer to be:
- ❖ The default printer, click **Yes**.
 - ❖ Available when specifically requested, click **No**.

- 10** Click **Next**.

- 11** Click **Finish**.

The Windows® XP operating system prints a test page.

- 12** To complete the setup, click **OK**.

You are now ready to print.

Depending on your program, you may see various messages indicating the status of your print job.



TECHNICAL NOTE: Some printers require a specific installation process. In this case, the Windows® XP operating system Add Printer Wizard will display an error message. If this happens, refer to your printer installation guide for further instructions.

Using the Wi-Fi® Wireless LAN Mini PCI module

Your computer may have an integrated Wi-Fi Wireless LAN Mini PCI module. It is recommended that you do not remove the module from your computer. For assistance, contact a Toshiba Wireless Authorized Service Partner.

For systems equipped with Wi-Fi, flip the wireless on/off switch to the On position.

Using an expansion device



The expansion port is used to connect your computer to an expansion device. This is an excellent investment if you are using your computer both in and out of the office.

When you return to your desk, you can then connect to your network, print reports from your computer, or use a mouse instead of the TouchPad. Connecting cables for each of these devices every time you return to the office is time-consuming and inconvenient.

With an expansion device, you can leave external devices connected while you are using your computer away from your desk. When you return, you can quickly connect your computer and have immediate access to all the devices.

For more information, see the accessories information package that comes with the device or visit accessories.toshiba.com.

Chapter 5

Enhancing Productivity

In this chapter, you will explore some of the special features of your Tecra® A2 Series notebook computer.

Exploring the desktop

The desktop is the launching pad for everything you can do in the Windows® XP Professional operating system. You use its features to start programs, find documents, set up system components, and perform most other computing tasks.



HINT: The illustrated examples in this guide may appear slightly different from the screens displayed by your system. The differences are not significant and do not indicate any change in the functionality of your system.

Finding your way around the desktop

Your computer's desktop includes several standard features: icons, Start button, taskbar, system tray, and background pattern.



Sample Windows® XP operating system desktop

Icons

An icon represents a folder, file, or program that can be quickly activated by double-clicking the icon.

You can create a new desktop icon for any folder, file, or program by dragging the element's icon from its location in a window to the desktop area.

The icons initially displayed on your system desktop include:



Recycle Bin — Holds files you have deleted. You may be able to retrieve these files until you empty the Recycle Bin.



TECHNICAL NOTE: If you delete a file from a diskette, it does not go into the Recycle Bin. For more information on the Recycle Bin, see Windows online Help.



Internet Explorer — The Microsoft® browser that provides access to the Internet.

NOTE

If you place the cursor over an icon, a popup description of the file contents appears.

Your desktop may contain other icons depending on your configuration. See Windows® XP online help for more specific information on each icon and how to use it.

Start button

You use the Start button to:

- ❖ Start programs
- ❖ Access Microsoft® Windows® XP operating system update information
- ❖ Open documents
- ❖ Adjust system settings
- ❖ Find files
- ❖ Access Windows® Help
- ❖ Run programs
- ❖ Suspend system activity and shut down the computer

Taskbar

Each time you open a program, a button associated with that program appears on the taskbar. With some programs, a button appears on the taskbar for each document or window you open. You can use these buttons to quickly switch between the programs or windows.

To make a program or window the currently active one, click the associated taskbar button.

You can personalize the taskbar to include not only shortcut icons but also your favorite Internet URL addresses.



DEFINITION: URL stands for Uniform Resource Locator, which is the address that defines the route to a file on the Web or any other Internet facility. Generically, it is known as the Web site address.

System tray

The System tray displays icons of tasks or programs that run continuously in the background. To learn more about each task, position the cursor over the icon for a few moments and a short description of the task appears.

Typical tasks in the System tray are Current time, Power usage mode, Mouse properties, and speaker volume.

To activate a specific task, double-click the appropriate System tray icon.

Setting up for communications

To connect to the Internet, use an online service, or communicate across the telephone lines with another computer, you need:

- ❖ A modem (one comes with your Tecra® A2 Series computer)
- ❖ A telephone line
- ❖ A browser or communications program
- ❖ An Internet Service Provider (ISP) or online service if you plan to use the Internet

Determining the COM port

Your modem is connected to one of the computer's COM (communications) ports. The default setting for the modem is COM3.

The following procedure is intended to support you if you need to either upgrade your modem or reset the port to the default settings.

If you are having trouble connecting through the modem, you may need to determine the current COM port name and possibly change it.

To find out which port your modem is connected to:

- 1** Open the **Start** menu, and click **Control Panel**.
- 2** Click **Printers and Other Hardware**.
- 3** Click **Phone and Modem Options**.

The **Phone and Modem Options** Properties dialog box displays.

- 4** Fill in the **Local Information** text boxes and click **OK**.
- 5** Click the **Modems** tab.

Your modem should be listed next to one of the computer's COM ports.

- 6 Make a note of the COM port number.
- 7 To verify that the modem is set up properly, select the modem you wish to check, and then click **Properties** to bring up the dialog box with information specific to that modem.

Windows XP communicates with the modem and displays identifying information reported by the modem. If Windows XP cannot communicate with the modem, it displays an error message. Consult the troubleshooting sections of your modem and Windows XP documentation.

- 8 Click **OK** to close the properties dialog box for that specific modem.
- 9 Click **OK** to close the Modem Properties dialog box.
- 10 Close the Control Panel.

Connecting the modem to a telephone line

Before you can use the modem, you must connect it to a standard voice-grade telephone line. For more information, see [“Connecting to a phone line” on page 159](#).

Connecting your computer to a network

You can connect your computer to a network to increase its capabilities and functionality using one of its communication ports.

Accessing a network

To access a network:

- ❖ At the office, connect an Ethernet cable to the RJ45 jack on your computer. For specific information about

connecting to the network, consult your network administrator.

- ❖ While you are at home or traveling, you need a dial-up connection. Ask your network administrator for the telephone number of the network.

Setting up the connection

To set up an office connection, consult your network administrator for network settings and additional considerations.

To set up a dial-up connection, use the New Connection Wizard:

- 1 Click **Start** and point to **All Programs**.
- 2 Point to **Accessories**, then to **Communications**, and click **New Connection Wizard**.
- 3 Enter the phone number of your network connection and let the program dial the number.

The computer connects to the network.

Using the Ethernet LAN Port

When your computer starts, Windows attempts to contact a Dynamic Host Configuration Protocol (DHCP) server. If the computer is not connected to a network, it may pause a few minutes as it waits for a reply. To avoid this delay, you can reconfigure Windows to disable the LAN port.

To disable the LAN port:

- 1 Click **Start**, click **Control Panel**, then **Performance and Maintenance**.
- 2 Click the **System** icon, then click the **Hardware** tab, and then click the **Device Manager** button.
- 3 Select **Intel® Pro/100 VE Network Connection in Network adapters**.

-
- 4 Click **Actions**.
 - 5 Select the **Properties** icon.
 - 6 Select the **Do not use this device (disable)** option from the **Device usage** drop-down.
 - 7 Click **OK**.

Your LAN port is now disabled.

To enable the Ethernet LAN port, repeat steps one through four. Select the **Use this device (enable)** check box, and click **OK**.

Setting up a wireless connection

For information on how to set up a wireless connection, refer to your wireless networking device documentation or your network administrator.

Using Wireless LAN Connectivity

NOTE The transmission speed over the wireless LAN and the distance over which wireless LAN can reach may vary depending on surrounding electromagnetic environment, obstacles, access point design and configuration, and client design and software/hardware configurations.

Your system may come with an optional wireless LAN module. This is a technology that expands wireless communication beyond networking equipment, and can connect many different kinds of electronic devices without the need for cables.

For information on how to set up a wireless connection, refer to your wireless networking device documentation or your network administrator.

To use your wireless communication, flip the wireless on/off switch to the On position.

An overview of using the Internet

The following sections give a quick introduction to the Internet and some of its exciting features, under these headings:

- ❖ [The Internet](#)
- ❖ [The World Wide Web](#)
- ❖ [Internet Service Providers](#)
- ❖ [Connecting to the Internet](#)
- ❖ [Surfing the Internet](#)
- ❖ [Internet features](#)
- ❖ [Uploading and downloading files from the Internet](#)

The Internet

The Internet is an association of thousands of networks and millions of computers around the world connected by communications lines. They all work together to share information.

The World Wide Web

The World Wide Web (or “Web”) is a subset of the Internet — a collection of interlinked documents (located on computers connected to the Internet) that work together using a specific Internet protocol called Hypertext Transfer Protocol (HTTP).

The World Wide Web offers information as text, images, audio, or video to be referenced from anywhere in the world. Special programs called Web browsers are specifically designed to work with HTTP. They make it easier to connect to a particular network address and send and receive information.

Internet Service Providers

To connect a computer directly to the Internet, many people and businesses use an Internet Service Provider (ISP). An ISP is a company that has the equipment and the telecommunication lines necessary to maintain an Internet connection.

You can connect to the Internet by using a telephone and modem or through other higher-speed communication methods such as Digital Subscriber Lines (DSL), cable, and satellite links.

Connecting to the Internet

To connect to the Internet, you need:

- ❖ A modem and telephone line, or a LAN connection
- ❖ A Web browser
- ❖ An Internet Service Provider (ISP) account

The Microsoft® Web browser Internet Explorer is automatically configured on your system so that when you first start it, it guides you through signing up for a new ISP account, or assists you in setting up your computer to work with your existing ISP.

Once you have established an ISP account, you can connect to the Internet.

- 1 Connect your computer's modem to a telephone line. For more information on connecting a modem, see [“Connecting your modem to a telephone line” on page 158.](#)



- 2 Start your Web browser. Have your modem dial the ISP's telephone number, and establish a connection with the ISP's computer.

If you are using your computer at the office, then you probably connect to the Internet through your company's network. See your network administrator about connecting to the Internet.

Surfing the Internet

Once connected to the Internet, the Web browser displays a home page, for example, your ISP's home page on the Internet or your company's Web site home page.

To visit a desired Web site, type in the Web address. The Web address, or Uniform Resource Locator (URL), is a unique identifier for that computer system linked to the Internet. Web addresses can also appear within a Web page's text, and are known as links. Clicking a link automatically transfers your Web browser to that site.

You can also use a Search Engine, a Web site specifically designed to help you look for information.

Internet features

The Internet offers many types of communication tools to help you perform many tasks.

❖ Internet email

To send and receive email of your own, you need a mailbox on the Web or an email address.

If you have an account with an ISP, you can probably set up an email address at the same time you sign up for the service.

❖ Internet chat rooms

A chat room is a Web site that offers a place where people with similar interests and ideas communicate in real-time, one-on-one or in groups, by typing messages which are instantly viewed by others on their computer screens.

❖ Internet news groups

A news group is similar to a chat room, but instead of using a dedicated site to converse about a specialized subject with others in real-time, it uses a Web site as a

clearinghouse where all the messages are placed, like a gigantic bulletin board.

❖ **Online shopping**

Many Web sites offer products and services for sale.

Uploading and downloading files from the Internet

Transferring files from one computer to another is termed uploading (transferring data from your computer to a site on the Web), or downloading (transferring data from a site on the Web to your computer).

There are several ways to upload or download data. It can be as simple as attaching a file or document to an email, or you can use the File Transfer Protocol (FTP) features of your Web browser to transfer large amounts of data.

Exploring audio features

You can use your computer to record sounds using an external microphone. You can play .wav sound files or audio CDs using the built-in speakers, headphones, or external speakers.

Playing an audio CD

Insert an audio CD and close the disc tray.

If the computer is turned on, Windows Media® Player opens and the CD begins to play. You can use the Windows Media Player program to control the CD.

To access the Windows Media Player, you can open it through the Start menu or activate it from the taskbar.

NOTE

When using Windows Media Player, your system may not be able to activate Standby or Hibernation modes. To prevent this from occurring, close Windows Media Player before you select Standby or Hibernation mode.

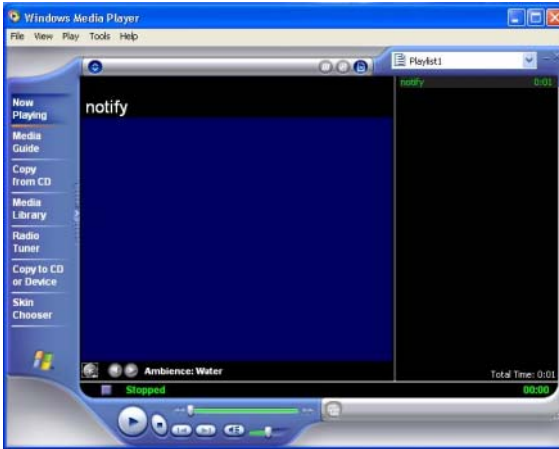

Sample Windows Media Player screen

The CD Player control panel works much like an ordinary compact disc player:

- ❖ To play the CD or to pause, click the **Play/pause** button on the CD Player control panel.
- ❖ To stop the CD, click the **Stop** button.

⚠ WARNING

Before using headphones to listen to an audio CD, turn the volume dial down. Playing the CD with the volume set too high could damage your ears.

Playing CDs using Auto-Run

If you insert a CD into the DVD-ROM/multi-function drive and the Auto-Run feature does not automatically start your disk, try launching the CD manually. To do this, follow these steps:

- 1 Open the **Start** menu and select **My Computer**.
- 2 Click the DVD-ROM/multi-function drive icon.

The disk drive will run the CD.

If your disk does not run using this method, try using an application that is associated with the media on the disk. For example, if it is a music CD, open Windows® Media Player and point it to play the CD. For other types of media, use the associated software to open the files on the disk.

Creating a CD

Your computer may come with a multi-function drive that allows you to:

- ❖ Play pre-recorded DVDs
- ❖ Play pre-recorded CDs
- ❖ Read and write data (depending on your system configuration) and music files to CD-Recordable (CD-R) and CD-Rewritable (CD-RW) discs; and read DVD-R/-RW or DVD RAM discs.

NOTE

Copy protection technology included in certain media may prevent or limit recording or viewing of the media.

For details on how to use the software, please refer to the respective Online Help menus.

Recording sounds

You may record sounds as .wav files by connecting an external microphone or other sound source to the microphone jack.



DEFINITION: A .wav (pronounced “wave”) file is a Windows® format for storing sound.



TECHNICAL NOTE: If you record MP3 files, you will only be able to play them on a device capable of playing MP3 files.

Using a microphone



- 1 Connect an external microphone to the computer.
- 2 Click **Start**, point to **All Programs**, **Accessories**, **Entertainment**, then click **Sound Recorder**.

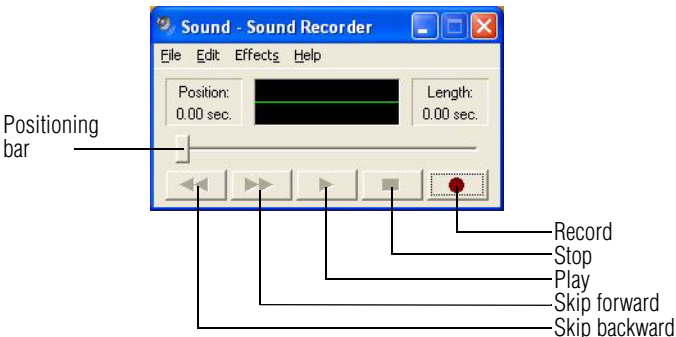

Sample Sound Recorder screen



- 3 Click the **Record** button.

- 4 Speak normally into the microphone.



- 5 When you have finished recording, click the **Stop** button.

The Sound Recorder window displays the new sound file as a waveform.

NOTE

You can only record 60 seconds at a time.



6 To hear what you just recorded, click the **Play** button.

7 To save the file, select **Save** from the **File** menu.

Adjusting recording quality

The better the quality of the recording, the more disk space the sound file requires. Experiment to find a balance that fits your needs.

- 1** Open Sound Recorder, if necessary. (Click **Start**, point to **All Programs, Accessories, Entertainment**, then click **Sound Recorder**.)
- 2** In the Sound Recorder window, click **Edit**, then click **Audio Properties**.
- 3** In the Audio Properties dialog box, adjust the Recording Volume, Preferred device, and Preferred quality.
- 4** Click **OK**.

Your new settings take effect the next time you record.

Using external speakers or headphones

Your computer is equipped with a full stereo sound system with internal speakers. Instead of using the internal speakers, you can connect headphones or a pair of external stereo speakers.



TECHNICAL NOTE: Use amplified speakers that require an external power source. Other types of speakers will be inadequate to produce sound from the computer.

To play back sound files through external speakers or headphones:



- 1 Locate the headphone jack on the computer.
 - 2 Using any necessary adapters, plug the cable from the headphones or external speakers into the headphone jack.
- The headphone jack requires a 16-ohm stereo mini-jack.

To adjust the volume:

- ❖ For external speakers, use the volume controls on each speaker.
- ❖ For headphones, use the computer's volume control dial.

Inserting and removing hard drives

Your Tecra® A2 can use various hard drive capacities. Depending upon the original hard drive installed in your computer, you may wish to increase storage capacity by changing the internal drive.

To change the internal hard drive:

- 1 Shut down your computer completely using the Shut Down command. See [“Powering down the computer” on page 106](#).
- 2 Unplug the computer.
- 3 Close the display panel and remove any cables you may have connected.
- 4 Turn the computer upside down.
- 5 Remove the screw on the hard drive cover.

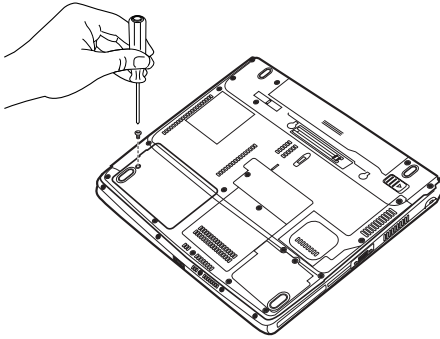

Sample removing the hard drive cover screw

- 6** Lift the edge of the hard drive cover and lift it up to expose the hard drive.
- 7** Grasp the edge of the hard drive and pull it toward the edge of the computer, then lift it straight up to remove it.

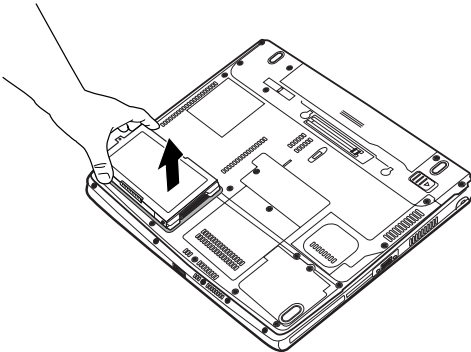

Sample removing the hard drive from the computer

- 8** Install the new hard drive by setting it into the hard drive slot and sliding back toward the center of the computer until it locks. Do not force the drive into the computer.

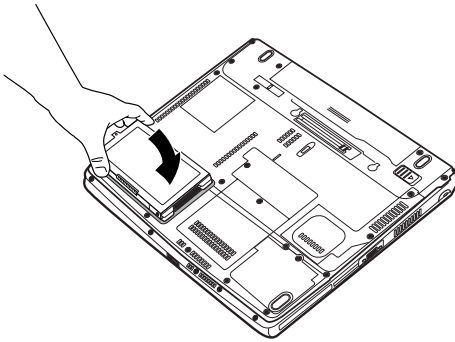

Sample inserting the new hard disk drive

- 9 Replace the hard drive cover and tighten the screw removed as previously mentioned in step 5.

Inserting and removing PC Cards

Your Tecra® A2 Series computer comes with one PC Card slot and supports two types of PC Cards:

- ❖ Type I cards—You can install one of these cards.
- ❖ Type II cards—You can install one of these cards.

Inserting a PC Card

NOTE

Use caution when lifting or turning your computer. Failure to do so may result in damage to components, such as cables, attached to your computer, or to the computer itself.

Before you insert a PC Card, refer to the documentation that comes with the card to see if you need to do anything before you insert it.

To insert a PC Card:

- 1 Turn off the computer.

You may also hot swap a PC Card. Stop the PC Card by clicking the **Safely Remove Hardware** icon on the System tray. After the PC Card is stopped, it is safe to remove.

- 2 Locate the PC Card slot on the left side of the computer.
- 3 Insert the PC Card.

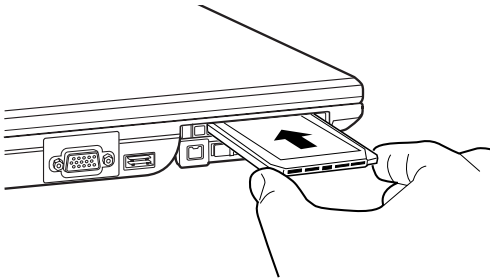

Sample inserting a PC Card

- 4 When the card is almost all the way into the slot, push firmly, but gently, to ensure a firm connection with the computer. Do not force the card into position.

Removing a PC Card

Stop the PC Card by clicking the **Safely Remove Hardware** icon on the System tray. After the PC Card is stopped, it is safe to remove.

- 1 Locate the PC Card ejection button.
- 2 Press the PC Card eject button once to extend it, and push it in to remove the PC Card.

The PC Card ejects slightly from the slot.

- 3 Grasp the edges of the PC Card and slide it out of the slot.

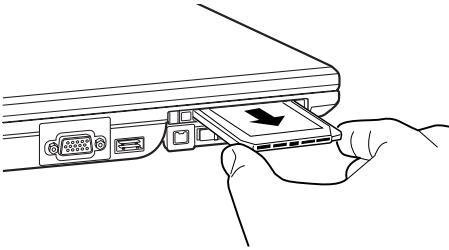

Sample removing a PC Card

Setting up a PC Card for your computer

Some PC Cards are ready to use as soon as you install them. Others, such as hard disk cards, network cards, and SCSI adapters, may need to be set up to work with your computer. To set up your PC Card, refer to the documentation that came with the card or refer to your operating system manual or online help.

Connecting your modem to a telephone line

Your computer comes with a built-in modem that can be connected to a standard voice-grade telephone line.

The modem allows you to:

- ❖ Access the Internet.
- ❖ Communicate with your office's local area network (LAN) or larger corporate wide area network (WAN).

For specific information about connecting to a LAN or WAN, consult your network administrator.

- ❖ Send a fax directly from your computer.

For more detailed information regarding your computer's modem, visit Toshiba's Web site at accessories.toshiba.com.

Connecting to a phone line

Before you can communicate using the modem, you need to connect it to a telephone line. Your computer's built-in modem port provides an RJ-11 jack, allowing you to connect the modem to a standard voice-grade telephone line.

- 1 Plug one end of a telephone cable (purchased separately) into the modem port on the back of the computer.

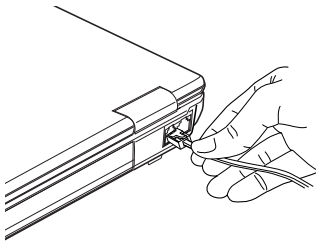

Sample connecting the telephone cable to the modem port

- 2 Connect the other end to the RJ-11 wall jack.

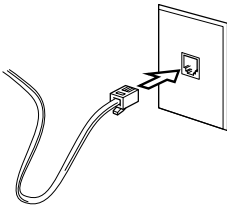

Sample connecting to a wall jack

CAUTION

The modem is designed for use with a standard analog telephone line. Do not connect the modem to a digital telephone line. A digital line will damage the modem.

Now you are ready to send a fax or use the modem to connect to an online service or the Internet.

For more information on using a modem, see [“Setting up for communications”](#) on page 142.

Chapter 6

Toshiba Utilities

Your computer includes several utilities designed to help you to reconfigure your system to best meet your individual needs. Together, these allow you to determine certain system details, set additional options, or change default options. This chapter describes the utilities supplied by Toshiba:

- ❖ Fn-esse®
- ❖ Hotkey utility
- ❖ TOSHIBA Console
- ❖ TOSHIBA HW Setup
- ❖ TOSHIBA Power Saver
- ❖ Enabling Hibernation
- ❖ Setting a user password
- ❖ Using a supervisor password
- ❖ Using the TOSHIBA Zooming Utility
- ❖ Using the TOSHIBA Touch and Launch utility
- ❖ TOSHIBA Mobile Extension
- ❖ TOSHIBA Application Installer

Fn-esse®

Desktop shortcuts and Toshiba's Fn-esse program provide quick ways to open programs, documents, and folders from within any Windows® program without using the Start menu. For more information on creating desktop shortcuts, refer to the operating system documentation that came with your computer.

This section describes how to use the Fn-esse program to quickly access your programs and files.

With Fn-esse, you can assign an Fn key combination to:

- ❖ Open a Windows® XP operating system program.
- ❖ Open a file in its associated program.
- ❖ Display a customized folder of programs and/or files from which to choose.

Fn-esse also has several keys, known as hot keys, that perform preassigned operations. For more information, see [“Hot Keys” on page 213](#).

You can assign any key that is not associated with a hot key or a keyboard overlay.

Starting Fn-esse®

Click **Start**, point to **All Programs**, **Toshiba Utilities**, then click **Fn-esse**.

The Fn-esse keyboard appears.



Sample Fn-esse window

The keys are color-coded as follows:

- ❖ Available keys are dark gray with white letters.
- ❖ Assigned keys and keys associated with a popup list are shown on the Fn-esse keyboard in the selected color.
- ❖ Unavailable keys are light gray.

There are two ways to assign a key to open a program or document:

- ❖ Using drag-and-drop
- ❖ Using the keyboard or pointing device

The method most often used is drag-and-drop.

Using drag-and-drop to assign a key

To assign a key to a program or document:

- 1 Start both Fn-esse and Windows[®] Explorer (or the program supporting drag-and-drop).
- 2 Resize the Explorer window so that you can see both the Fn-esse keyboard and Explorer at the same time.
- 3 In the Explorer window, highlight the program or document file you wish to assign to a key.
- 4 Click and hold the primary button as you drag the highlighted item from Explorer to the key on the Fn-esse keyboard to which you want to assign it.
- 5 Release the primary button.

Fn-esse displays the Add/Edit Command dialog box with the Description, Command Line, and Working Directory fields automatically completed.

- 6 Click **OK** to close the Add/Edit Command dialog box with your key assignment in place.

The program or document is now associated with the key you just selected. To open the program or document, press Fn plus the appropriate key from within any Windows program.

Using the keyboard or pointing device to assign keys

To assign a key to open a program or document, start Fn-esse and either:

- ❖ Using the keyboard, press and hold the Fn key, then press the desired assignment key.
- ❖ Using the pointing device, move the cursor over the desired key in the Fn-esse window and press the secondary button.

The Assignment Type dialog box appears.

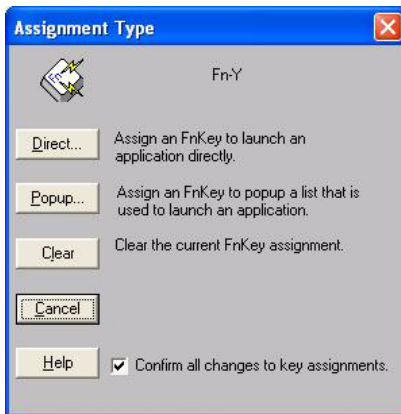

Sample Fn-esse assignment type dialog box

Making a direct key assignment

- 1 Select **Direct...** to display the Add/Edit Command dialog box.
- 2 Enter the Description, Command Line, and Working Directory for the new Fn-esse key assignment, or click **Browse** to specify this information.
- 3 Click **OK**.

Making a popup assignment

- 1 Select **Popup...** to display the Application Explorer dialog box.
- 2 Select the desired folder. The left side of the Application Explorer window displays the folders in the Programs menu. The right side lists the programs and documents in the folder. These are the items that will appear in the popup list.
- 3 To create a popup list with items from various folders, or to pick only a few items from a folder, create a new folder containing only the desired programs and documents. If you are unsure how to do this, refer to your Windows® XP operating system documentation.
- 4 Click **OK** to associate the folder with the key you just selected.

To open a popup list showing the items in that folder, press Fn plus the appropriate key from within any Windows® program.

Viewing existing key assignments

To view the existing key assignments, choose **Assignments** from the Fn-esse keyboard. Fn-esse displays the Function Key Assignments dialog box. This box lists all the key assignments and the program or document to which each key is assigned.

To view items in a popup list, select the **Expand popup lists** check box.

Changing or removing existing key assignments

In the Fn-esse keyboard, click the key you wish to change with the secondary button.

Fn-esse displays the Assignment Type dialog box.

- ❖ To change the key assignment, click **Direct...** or **Popup...** and continue as if you were creating a new assignment.
- ❖ To remove the key assignment, click **Clear**.

TOSHIBA Console

The TOSHIBA Console provides quick access to computer functions and allows you to customize a range of computer settings.

To access the control panel:

- 1 Click **Start**, then click **All Programs**.
- 2 Point to **TOSHIBA Console**, then click the resulting **Toshiba Console** selection.

The TOSHIBA Console window appears.



Sample TOSHIBA Console window

The TOSHIBA Console offers three categories of features:

- ❖ Customizing Your Computer
- ❖ Network
- ❖ Security

Customizing Your Computer

The features available in this category are:

- ❖ Power Management
- ❖ Mouse
- ❖ Hotkey assignment (for detailed information, see “Fn-esse®” on page 161)
- ❖ Toshiba Hardware Settings
- ❖ Toshiba Button Control
- ❖ ConfigFree
- ❖ CD/DVD Drive Acoustic Silencer
- ❖ TOSHIBA Application Installer

Network

The Network category features Connectivity Doctor.

Security

The features available in this category are:

- ❖ Supervisor password
- ❖ User password

TOSHIBA Power Saver

The TOSHIBA Power Saver feature enables you to control your computer’s power usage, regardless of the source, and use the many preset power modes, or create one yourself.



To access Power Management through the TOSHIBA Console, double-click the **Power Management** icon.

The TOSHIBA Power Saver Properties window appears.

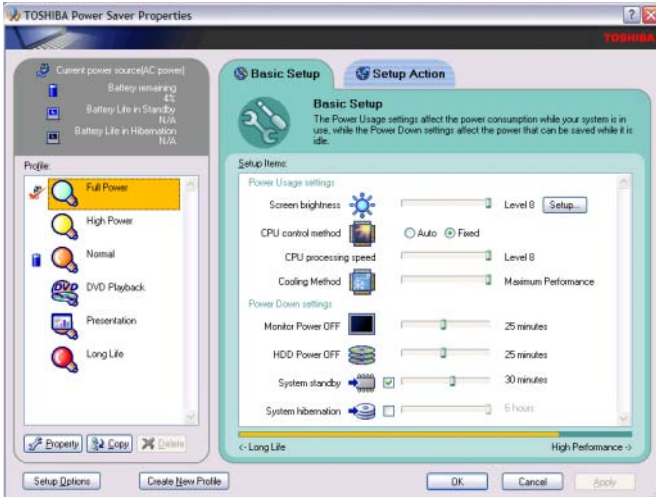

Sample TOSHIBA Power Saver Properties window

The Power Properties window shows the power profiles, which are optimized for several different working environments.

You can either use one of the preset modes or create and use your own customized profile. The preset profiles cannot be deleted.

By changing the options that appear in the Toshiba Power Saver Properties window and clicking **OK**, you can reconfigure that function. Any options that you change become effective when you click either **OK** or **Apply**.

Profiles

This section lists the preset profiles along with the estimated battery life for each mode. The preset profiles are:

- ❖ Full Power
- ❖ High Power

- ❖ Normal
- ❖ DVD Playback
- ❖ Presentation
- ❖ Long Life

Although you can change the properties for any of these profiles, this is not recommended. If you need a customized profile, create a new profile with the properties you require.

The DVD Playback profile applies only when a DVD program is playing.

Quickly creating a new power mode

- 1 Highlight one of the preset profiles.
- 2 Click **Copy**.
- 3 A new mode appears with the title “*Copy of Name*” where *Name* is the title of the mode you copied. You can change the name, description, or icon for this profile by clicking **Property**.

Customizing a power mode

- 1 Highlight the profile you want to modify.
- 2 Change the settings you want on the **Basic Setup** tab.
- 3 You may also change settings on the **Setup Action** tab. Keep in mind however, that by default, these actions will apply to all profiles.

Mouse utility

The Mouse utility allows you to change your TouchPad or mouse settings. To access the Mouse utility through the TOSHIBA Console, double-click the **Mouse** icon.

Hotkey utility

The Hotkey utility allows you to receive a confirmation message when you use the Hotkey combination for Standby [Fn+F3] and Hibernation [Fn+F4].

To activate:

- 1 Click **Start, All Programs, Toshiba, Utilities**, then click the **Hotkey** utility.

The Hotkey window appears.



Sample Toshiba Hotkey utility window

- 2 Select the desired option.
- 3 Click **OK**.

TOSHIBA Mobile Extension

To adjust the settings for docking or using the Slim SelectBay, use the TOSHIBA Mobile Extension Service Configuration.

To use the TOSHIBA Mobile Extension Service Configuration:

- 1 Click **Start**, then **Control Panel**, then **Performance and Maintenance**.

2 Click TOSHIBA Mobile Extension.

The TOSHIBA Mobile Extension Service Configuration dialog box appears.

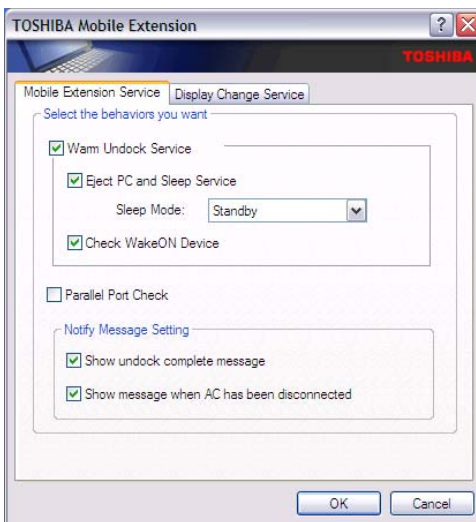
3 Under the Mobile Extension Service tab, you can select behaviors to enable or disable, like Warm Undock Service and Notification Messages, by checking or unchecking the appropriate box.

Sample TOSHIBA Mobile Extension Service tab options

4 Under the Display Change Service tab, you can set the default display configuration you wish to use when docking the system to the optional Advanced Port Replicator III.

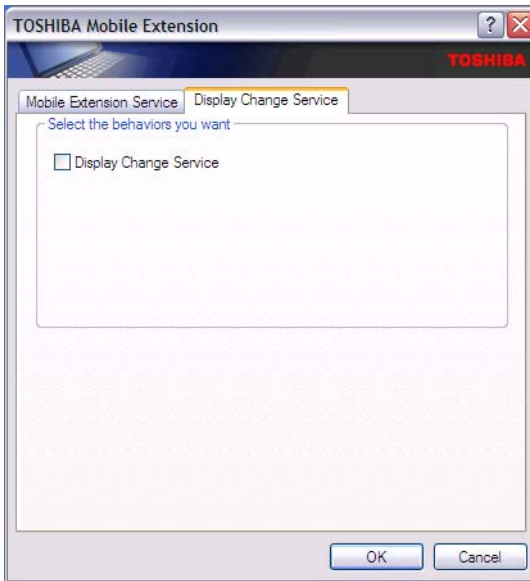

Sample Display Change Service tab options

TOSHIBA HW Setup

TOSHIBA HW Setup is the Toshiba configuration management tool available through Windows. To access it, open the **Start** menu, click **Control Panel**, then **Printers and Other Hardware**. Then click the **Toshiba HWSetup** icon.

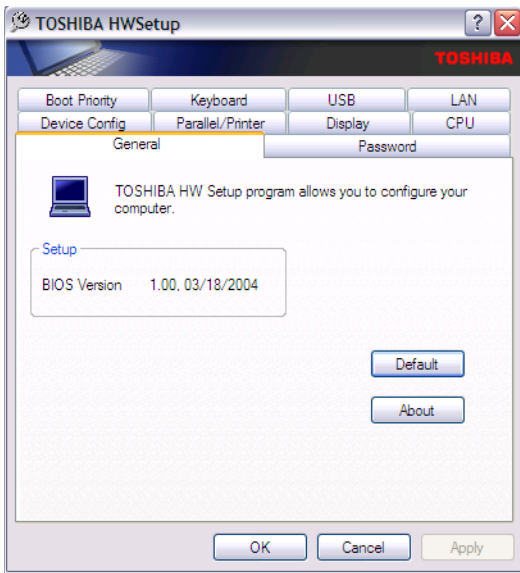

Sample TOSHIBA HWSetup window

The tabs represent various dialog boxes. They are:

- ❖ **General**—Allows you to view current BIOS, hard disk drive and memory settings
- ❖ **Password**—Allows you to set or reset a user password for the power-on process and for instant security.
- ❖ **Device Config**—Shows the Device configuration options.
- ❖ **Parallel/Printer**—Allows you to configure the parallel port default settings (if applicable to your system)
- ❖ **Display**—Allows you to change various default settings for the built-in LCD display
- ❖ **CPU**—Allows you to change the dynamic CPU frequency mode

Dynamically Switchable—This mode is the default setting for your computer, and automatically changes the processing frequency and decreases voltage depending on the power source:

- ❖ AC Power—If your computer is connected to the AC adapter, the CPU frequency mode is set to high for faster processing.
- ❖ Battery Power—If your computer is running on battery power, the CPU frequency mode is set to low for slower processing. Switching the CPU to low allows you to conserve power and extend the operating time of your battery.
- ❖ Boot Priority—Allows you to change the sequence in which your computer searches the drives for the operating system
- ❖ Keyboard—Allows you to configure an external PS/2 keyboard to emulate the Fn function key and access the wake-on keyboard function
- ❖ USB—Allows you to enable or disable USB Legacy Emulation.
- ❖ LAN—Allows you to set networking functions

By changing any of the options that appear in the dialog boxes and clicking **Apply**, you can reconfigure that function. Any options that you change will become default settings when you restart your system.

Enabling Hibernation

Your computer includes a Toshiba Power Saver utility that allows you to change many of your default power settings. You can enable hibernation through this utility.

To power down the computer using the Hibernation option, click **Start**, select **Turn off computer**. When you hold down the Shift key, the Standby button changes to Hibernate. Hold down the Shift key, then select **Hibernate**.

The computer saves the state of the system, including all open programs and files, to the hard disk, and then powers down completely.



TECHNICAL NOTE: Toshiba recommends that you always have the Hibernation option enabled. Hibernation is the function that causes your system to save anything you have in short-term memory to the hard disk drive should your battery fail. If Hibernation is not enabled and your battery dies, you will lose data.

Setting user passwords

Setting a password leaves your computer secure so that nobody can access your files. You must enter the password before you can work on your computer.

Toshiba supports the several types of passwords on your computer:

- ❖ An instant password — Secures your open programs and files when leaving the computer temporarily
- ❖ A power-on password — Prevents unauthorized users from starting or restarting the computer
- ❖ A supervisor password — Prohibits unauthorized users from accessing certain functions such as Toshiba Hardware Setup. This is useful if more than one person uses the computer.

A single user password supports the instant and power-on password functions.

When setting up the various passwords, keep the following in mind:

- ❖ The user password can be set up under the supervisor password.

-
- ❖ The supervisor password must be set before the user password, or the user password must be deleted and then re-entered after the supervisor password is set.
-



TECHNICAL NOTE: When you delete the supervisor password, the user password is also deleted.

Using an instant password

An instant password secures your system with a single keystroke. Use this feature when you leave your desk for a few minutes and do not want to turn off the computer.

To use an instant password, press **Fn**, then press **F1**. This freezes the keyboard and TouchPad, and blanks the screen. An instant password has no effect on an optional USB mouse or trackball.

To unlock your system, press **Enter** and the Windows Logon screen will appear. Select your user name and enter your password, if any.

Setting a user password

To register a password for the power-on password functions:

- 1 Click **Start**, then click **All Programs**.
- 2 Point to **TOSHIBA Console**, then click the resulting **TOSHIBA Console** selection.

The TOSHIBA Console window appears.

- 3 On the left side, select **Security**.
- 4 Select the **User Password** icon.
- 5 Click **Set**.
- 6 Type your password in the **Input** box.
- 7 Retype your password in the **Input** again box.

- 8 Click **Set**.
- 9 Click **OK**.

Disabling a user password

To cancel the power-on password function:

- 1 Click **Start**, then click **All Programs**.
- 2 Point to **TOSHIBA Console**, then click the resulting **TOSHIBA Console** selection.

The TOSHIBA Console window appears.

- 3 On the left side, select **Security**.
- 4 Select the **User Password** icon.
- 5 Select **Verify by Password**.
- 6 Type the correct password.
- 7 Click **Delete**.
- 8 Click **OK**.

Using a supervisor password

A supervisor password prevents other users from changing hardware configuration options.

Setting a supervisor password

To register a password for the power-on password functions:

- 1 Click **Start**, then click **All Programs**.
- 2 Point to **TOSHIBA Console**, then click the resulting **TOSHIBA Console** selection.

The TOSHIBA Console window appears.

- 3 On the left side, select **Security**.

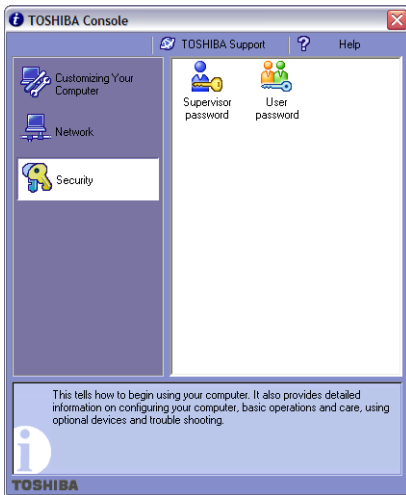

Sample TOSHIBA Console Security window

- 4 Select the **Supervisor Password** icon.
- 5 Click **Set**.
- 6 Type your password in the **Input** box.
- 7 Retype your password in the **Input** again box.
- 8 Click **Set**.
- 9 Click **OK**.

Deleting a supervisor password

To cancel the power-on password function:

- 1 Click **Start**, then click **All Programs**.
- 2 Point to **TOSHIBA Console**, then click the resulting **TOSHIBA Console** selection.

The TOSHIBA Console window appears.

- 3 On the left side, select **Security**.
- 4 Select the **Supervisor Password** icon.
- 5 Select **Verify by Password**.
- 6 Select the **Supervisor Password** tab.
- 7 Type the correct password.
- 8 Click **Verify**.
- 9 Click **Delete**.
- 10 Select **Verify by Password**.
- 11 Type the correct password.
- 12 Click **Verify**.

Using the TOSHIBA Zooming Utility

This utility allows you zoom in and zoom out of applications as well as the icons for Microsoft® Internet Explorer, Microsoft® Office, Windows® Media Player™, and Adobe® Reader.

To access the utility, click **Start, All Programs, Toshiba, Utilities**, and then **TOSHIBA Zooming Utility**.

The TOSHIBA Zooming Utility screen appears.

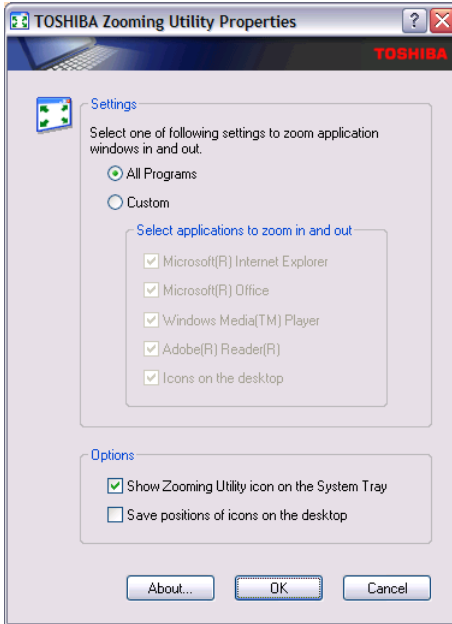

Sample TOSHIBA Zooming Utility screen

Using the TOSHIBA Touch and Launch utility

TOSHIBA Touch and Launch is a program that adds features to the TouchPad. For example, by selecting an icon you can:

- ❖ Open a document
- ❖ Launch a program
- ❖ Show a list of windows and switch the active window
- ❖ Open Internet Explorer favorites

TOSHIBA Touch and Launch is like a miniature Windows® desktop. You can personalize TOSHIBA Touch and Launch to help you work more efficiently.

To activate TOSHIBA Touch and Launch, touch and hold your finger on a corner of the TouchPad. The TOSHIBA Touch and Launch window appears.



Sample TOSHIBA Touch and Launch window

A blue circle within the TOSHIBA Touch and Launch window represents your finger location on the TouchPad. As you move the blue circle over an icon in the TOSHIBA Touch and Launch window, the icon is highlighted or selected. Release your finger from a selected icon to choose the icon's function. If the icon is highlighted in orange and selected, the function corresponding to the selected icon launches and the TOSHIBA Touch and Launch window closes. If the icon is highlighted in blue and selected, the function corresponding to the selected icon launches and the TOSHIBA Touch and Launch window remains open.

To close the TOSHIBA Touch and Launch window, release your finger when the blue circle is not on any icon. Or, highlight the Close icon in the upper right area of the TOSHIBA Touch and Launch window.

The TOSHIBA Touch and Launch window has the following parts:

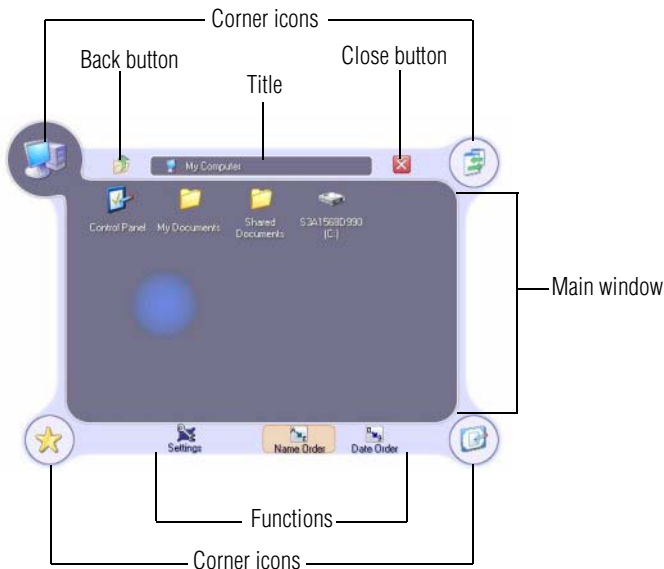

Sample parts of the TOSHIBA Touch and Launch window

A short description of the currently selected corner icon appears below the TOSHIBA Touch and Launch window.

The title and functions can change when you select one of the corner icons.

The type and number of icons you see in the main part of the TOSHIBA Touch and Launch window are determined by which of the corner icons you select.

TOSHIBA Touch and Launch is controlled/adjusted via an icon on the system tray. The icon will change color when the TOSHIBA Touch and Launch is active. Double-click the icon to open the TOSHIBA Touch and Launch Settings window. Right-click the icon to see the following shortcuts:

❖ Settings

The Settings function allows you to define the functions/features you can access in TOSHIBA Touch and Launch

❖ Disable/Enable

❖ Help

❖ About

TOSHIBA Touch and Launch Settings

When you choose the Settings shortcut menu entry, the TOSHIBA Touch and Launch Settings window appears.

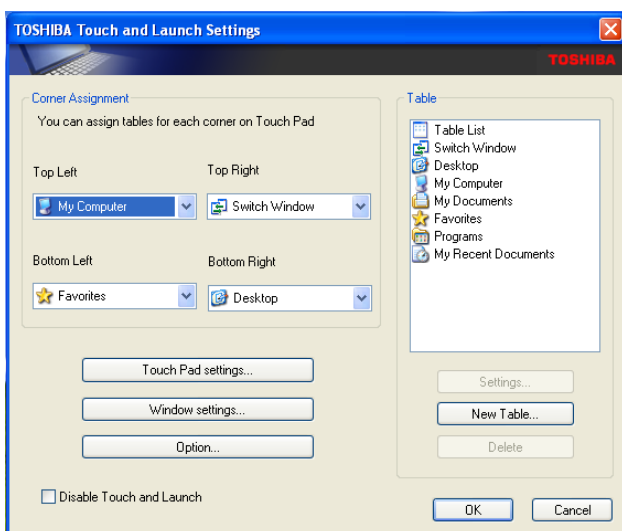

Sample TOSHIBA Touch and Launch Settings window

In the Corner Assignment section you can change the icons you see at the four corners of the TOSHIBA Touch and Launch window using the drop-down list boxes. The icons are referred to as tables in the TOSHIBA Touch and Launch Settings dialog box.

The TouchPad settings button allows you to define how sensitive the TouchPad will be to your finger on the TouchPad before it activates the TOSHIBA Touch and Launch window.

The Window settings button allows you to control the size and transparency of the TOSHIBA Touch and Launch window.

The Option button allows you to define how folders will open, define visual effects and control when to show help.

A list of tables appears in the Table section of the TOSHIBA Touch and Launch Settings window. These are the same items (icons) you can choose in the Corner Assignment section of the TOSHIBA Touch and Launch Settings. As you select a table, the Settings button may become active. Not all tables have settings.

The New Table button allows you to create a new table.

The Delete button deletes the selected table.

Disabling or enabling TOSHIBA Touch and Launch

You can set/clear the Disable TOSHIBA Touch and Launch check box in the TOSHIBA Touch and Launch Settings window to disable/enable the TOSHIBA Touch and Launch feature. You can also disable/enable TOSHIBA Touch and Launch via the TOSHIBA Touch and Launch icon on the system tray.

TOSHIBA Application Installer

The TOSHIBA Application Installer allows you to reinstall the drivers and applications that were originally bundled with your computer.

To reinstall drivers and applications:



- 1 Double-click the **Toshiba Application Installer** icon on the Windows desktop.
- 2 Click **Next**.



Sample TOSHIBA Application Installer screen

- 3 Click the item(s) you want to install. To select multiple items, hold down the Ctrl key as you make your selections.

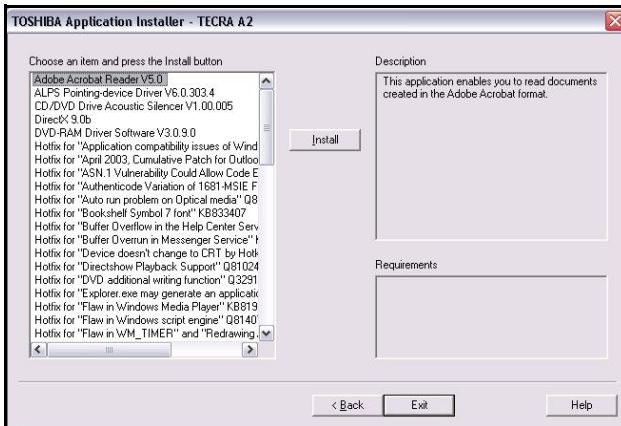

Sample TOSHIBA Application Installer selection screen

- 4 Click **Install**.
- 5 Follow the on-screen prompts to complete the installation process.

Chapter 7

If Something Goes Wrong

Some problems you may encounter when using your notebook computer are relatively easy to identify and solve. Others may require help from your dealer or the manufacturer of a software program.

This chapter aims to help you solve many problems by yourself. It covers the problems you are most likely to encounter. If all else fails, contact Toshiba. You will find information on Toshiba's support services at the end of this chapter.

Problems that are easy to fix

Your program stops responding.

If you are working with a program that suddenly freezes all operations, chances are the program has stopped responding. You can exit the failed program without shutting down the operating system or closing other programs.

To close a program that has stopped responding:

- 1 Press Ctrl, Alt, and Del simultaneously (once).

The Windows Task Manager window appears.

- 2 Click the **Applications** tab.

If a program has stopped responding, the words “not responding” appear beside its name in the list.

- 3 Select the program you want to close, then click **End Task**.

Closing the failed program should allow you to continue working. If it does not, continue with step 4.

- 4 Close the remaining programs one by one by selecting the program name, then **End Task**.

- 5 Click **Start, Turn off computer**.

The Turn off computer window appears.

- 6 Click **Turn off**.

The computer turns off.

Your program performs an illegal operation.

If you receive the message, “Your program has performed an illegal operation,” you should record the details of the message and consult the software manufacturer.

To record the details:

- 1 Click the **Details** button and select the text the operating system displays.

The Details button displays information that the software manufacturer needs to help you solve your problem.

- 2 Press Ctrl and c simultaneously to copy the text to the clipboard.
- 3 Open Notepad (click **Start**, point to **All Programs**, then point to **Accessories** and click **Notepad**).
- 4 Press Ctrl and v simultaneously to paste the details into Notepad.
- 5 Add a paragraph break and type some notes describing what you were doing when you received the message.

- 6 Save the file and refer to it when you contact the software manufacturer.

Problems when you turn on the computer

These problems may occur when you turn on the power.

The computer will not start.

Make sure you attached the AC adapter and power cord/cable properly or installed a charged battery.

Press and hold down the power button for a few seconds.

If you are using the AC adapter, check that the wall outlet is working by plugging in another device, such as a lamp.

The computer starts but, when you press a key, nothing happens.

You are probably in Stand By mode and have a software or resource conflict. When this happens, turning the power on returns you to the problem instead of restarting the system. To clear the condition, press Ctrl, Alt, and Del simultaneously.

Clearing the condition may get the computer running, but it will not solve a resource conflict. Read the documentation that came with the conflicting device and [“Resolving a hardware conflict” on page 191](#).

The computer is not accessing the hard disk or the external diskette drive.

Your computer normally loads the operating system from the hard disk. If you have a hard disk problem, you will not be able to start the computer. Insert a system diskette into the external diskette drive and press F12 when the machine starts, and then use the arrow keys to select the boot-up device.

For more information, see [“Hard Drive Recovery Utilities” on page 62](#).

The computer displays the WARNING RESUME FAILURE message.

The computer was placed in Stand By mode and the battery has discharged. Data stored in the computer's memory has been lost.

To charge the battery, leave the computer plugged into a live wall outlet for several hours. For more information, see [“Power and the batteries” on page 195](#).

The computer displays the Non-system disk or disk error message.

Make sure there is no diskette in the diskette drive. If there is one, remove it and press any key to continue. If pressing any key does not work, press Ctrl, Alt, and Del to restart the computer.

The Windows® operating system is not working

Once you are familiar with the desktop and used to the way the operating system responds to your work routine, you can easily detect if the operating system is not working correctly. For example:

- ❖ The operating system fails to start after the Starting Windows XP message appears.
- ❖ The operating system takes a long time to start.
- ❖ The operating system responds differently from the normal routine.
- ❖ The screen does not look right.

Unless a hardware device has failed, problems usually occur when you change the system in some way such as installing a new program or adding a device.

If you experience any of these problems, use the options in the Startup menu to fix the problem.

Using Startup options to fix problems

If the operating system fails to start properly, you may have to change your system's configuration or verify the startup procedure to fix the problem. To do this, use the options in the Startup menu. This section describes each option and when to use the procedure.

To open the Startup menu:

- 1 Restart your computer.
- 2 Press F8 when your computer starts.

The Windows® Advanced Options menu displays these options:

- ❖ Safe Mode
- ❖ Safe Mode (with Networking)
- ❖ Safe Mode (with Command Prompt)
- ❖ Enable Boot Logging
- ❖ Enable VGA Mode
- ❖ Last known good configuration (your most recent settings that worked)
- ❖ Directory Services Restore Mode (Windows® domain controllers only)
- ❖ Debugging Mode
- ❖ Start Windows® normally
- ❖ Reboot
- ❖ Return to OS Choices (menu)

See your Windows® documentation for further explanation.



TECHNICAL NOTE: If your computer is connected to a network, the Startup menu may display different versions of Safe mode.

Internet problems

My Internet connection is very slow.

Many factors contribute to the speed with which you can surf the Internet. They include: modem speed, time of day (when everyone else is surfing, your access can be slow), and popularity of the site. If accessing a particular site is very slow, try later.

My browser cannot find the URL address I typed in.

Make sure you separated the domain names of the address with the forward slash (/). Check the spelling of each name and the syntax of the address carefully. A single incorrect letter or missed character, comma instead of period (“dot”), or other mistake makes it impossible for your browser to locate the site.

My browser cannot find a site I bookmarked.

The World Wide Web is constantly changing. A site you bookmarked yesterday may not be available today or its server may be down for temporary repair. Try again later.

The Windows® XP operating system can help you

If the operating system has started properly, but you still have a problem using your computer, the online Help can assist you in troubleshooting the problem.

To access Windows® XP Help and Support:

- 1** Click **Start**, then click **Help and Support**.

The Help and Support window appears.

- 2 Then do one or both of the following:
 - ❖ In the search field, type the topic of the problem with which you need help and follow the on-screen instructions.
 - ❖ Click a problem you about which would like help from the listings and follow the on-screen instructions.

You can connect to Support Online by clicking **Support** from the menu.

Resolving a hardware conflict

If you receive an error message telling you there is a device driver conflict or a general hardware problem, try using Windows® Help and Support to troubleshoot the problem first.

For help on hardware conflicts:

- 1 Click Start, then click **Help and Support**.
- 2 Click the **Hardware** link in the window's left pane.
A list of category links appear.
- 3 Click the **Fixing a hardware problem**.
- 4 Choose from specific topics and follow the steps.

If there is still a problem, the operating system should display a message that explains what the conflict is.

A plan of action

The smooth operation of the system depends on the interaction of all devices, programs, and features. If the system or one of its attached devices is not working, resolving the problem can be time-consuming and frustrating.

The recommended procedure for getting multiple devices to work together is to add and set up one device at a time. After you add each device, test it to make sure it and all previously connected devices work.

The device most recently connected to the system is the one most likely to be causing a hardware conflict.

Resolving hardware conflicts on your own

Computer components need resources to accomplish a task. A device, such as a disk drive or a modem, needs a channel to the computer's Central Processing Unit (CPU). It also needs a direct channel to the computer's memory to store information as it works. These channels of communication are commonly referred to as system resources.

Interrupt Request Channel

The channel to the CPU is called an Interrupt Request (IRQ) because it interrupts what the processor is doing and requests some of the processor's time.

Direct Memory Access

Similarly, the data required by the device is stored in a specific place or address in memory called the Direct Memory Access (DMA). The DMA provides a dedicated channel for adapter cards to bypass the microprocessor and access memory directly. If two or more devices use the same DMA, the data required by one device overwrites the data required by the other, causing a hardware conflict.

Resolving conflicts

There are three things you can do to resolve hardware conflicts:

- ❖ Disable the device.

For an older device, remove it from the computer.

-
- ❖ Disable another system component and use its resources for the new device, see “Fixing a problem with Device Manager” below.
 - ❖ Reconfigure the device so that its requirements do not conflict. Refer to the device’s documentation for instructions about changing settings on the device.

Fixing a problem with Device Manager

Device Manager provides a way to check and change the configuration of a device.

CAUTION

Changing the default settings using Device Manager can cause other conflicts that make one or more devices unusable. Device Manager is a configuration tool for advanced users who understand configuration parameters and the ramifications of changing them.

Disabling a device

- 1 Open the **Start** menu, click **Control Panel**, then **Performance and Maintenance**.
- 2 Click the **Administrative Tools** icon.
- 3 Click the **Computer Management** and then **Device Manager**.
- 4 Select the specific device from the device category.
- 5 In the toolbar, look to the far right for an icon of a monitor with a strike mark through a circle on the front. This is the disable feature.
- 6 Click the icon.
You are given the option of disabling the device.
- 7 Click **yes** or **no**, whichever is appropriate.

Checking device properties

Device Manager provides a way to view the properties of a device. Properties include the name of the manufacturer, the type of device, the drivers installed, and the system resources assigned to the device.

To check a device's properties:

- 1 Open the **Start** menu, then click **Control Panel**.
- 2 Click **Performance and Maintenance**, and then **Administrative Tools**.
- 3 Click the **Computer Management** icon.
- 4 Click the **Device Manager** button.
- 5 To view the device(s) installed, double-click the device type.
- 6 To view the properties, double-click the device.

The operating system displays the Device Properties dialog box, which provides an array of tabs. They include:

- ❖ The **General** tab, which provides basic information about the device.
- ❖ The **Resource** tab, which lists resources assigned to the monitor, DVD-ROM, multi-function drive, diskette disk drive, and other power-using functions.
- ❖ The **Drivers** tab, which displays the drivers being used by the device.

A Troubleshooting button is also present.

- 7 Click **troubleshooting**.

A Help and Support window for that device appears.

For more information about Device Manager, refer to Windows® XP online help.

Memory problems

Incorrectly connected or faulty memory modules may cause errors that seem to be device-related. It is worthwhile checking for these first:

- 1 Click **Start**, then click **Turn off computer**.
- 2 Click **Turn Off**.
The operating system shuts down and turns off the computer automatically.
- 3 Remove the memory module.
- 4 Reinstall the memory module, following the instructions in [“Adding memory” on page 55](#), and making sure it is seated properly.
- 5 Check for the error again.
- 6 If the error recurs, remove the memory module entirely and check for the error again.

If removing the memory module eliminates the error, the memory module may be faulty. If the error recurs without the memory module installed, the error is not caused by the memory module.



TECHNICAL NOTE: You must have at least one memory module installed for the computer to work.

Power and the batteries

Your computer receives its power through the AC adapter and power cord/cable or from the system batteries (main battery and real-time clock (RTC) battery). Power problems are interrelated. For example, a faulty AC adapter or power cord/cable will neither power the computer nor recharge the batteries.

Here are some typical problems and how to solve them:

The AC power light does not come on when you plug in the AC adapter and power cord/cable.

Make sure the AC adapter and power cord/cable are firmly plugged into both the wall outlet and the computer.

If the AC power light still does not come on, check that the wall outlet is working properly by plugging in a lamp or other appliance.

The AC adapter and power cord/cable work correctly, but the battery will not charge.

The battery does not charge while the computer is consuming full power. Try turning off the computer.

The main battery may not be inserted correctly in the computer. Turn off the computer, remove the battery, clean the contacts with a soft dry cloth (if necessary), and replace the battery.

The battery may be too hot or too cold to charge properly. If you think this is the probable cause, let the battery reach room temperature and try again.

If the battery has completely discharged, it will not begin charging immediately. Leave the AC adapter and power cord/cable connected, wait 20 minutes and see if the battery is charging.

If the battery light is glowing after 20 minutes, let the computer continue charging the battery for at least another 20 minutes before you turn on the computer.

If the battery light does not glow after 20 minutes, the battery may have reached the end of its useful life. Try replacing it.

The battery appears not to power the computer for as long as it usually does.

If you frequently recharge a partially charged battery, it may not charge fully. Let the battery discharge completely, then try charging it again.

Check the power options using the Power Management utility. Have you added a device, such as a PC Card or memory module, that takes its power from the battery? Is your software using the hard disk more? Is the display power set to turn off automatically? Was the battery fully charged to begin with? All these conditions affect how long the charge lasts.

Keyboard problems

If, when you type, strange things happen or nothing happens, the problem may be related to the keyboard itself.

The keyboard produces unexpected characters.

A keypad overlay may be on. If the numeric keypad or cursor control light is on, press Fn and F10 simultaneously to turn off the cursor control light or press Fn and F11 simultaneously to turn off the numeric keypad light.

If the problem occurs when both the keypad overlays are off, make sure the software you are using is not remapping the keyboard. Refer to the software's documentation and check that the program does not assign different meanings to any of the keys.

You have connected an external keyboard and the operating system displays one or more keyboard error messages.

If you have a second keyboard, try it. If it works, the first keyboard may be defective or incompatible with your computer.

Display problems

Here are some typical display problems and their solutions:

The display is blank.

Display Auto Off may have gone into effect. Press any key to activate the screen.

You may have activated the instant password feature by pressing Fn and F1 simultaneously. If you have registered a password, press the Enter key, type the password, and press Enter. If no password is registered, press Enter. The screen reactivates and allows you to continue working.

If you are using the built-in screen, make sure the display priority is not set for an external monitor. To do this, hold the Fn key and press F5 twice. A window with display choices pops up. Hold the Fn key and press F5 twice again to advance through the display options.

If you are using an external monitor:

- ❖ Check that the monitor is turned on.
- ❖ Check that the monitor's power cable is firmly plugged into a working power outlet.
- ❖ Check that the cable connecting the external monitor to the computer is firmly attached.
- ❖ Try adjusting the contrast and brightness controls on the external monitor.
- ❖ Press Fn and F5 simultaneously to make sure the display priority is not set for the built-in screen.

The screen does not look right.

You can change the display settings by clicking a blank area of the desktop with the secondary control button, then clicking Properties. This opens the Display Properties dialog box. The Appearance tab of this dialog box allows you to choose the colors for the screen. The Settings tab allows you to choose the screen resolution.

The built-in screen flickers.

Some flickering is a normal result of the way the screen produces colors. To reduce the amount of flickering, try using fewer colors.

To change the number of colors displayed:

- 1** Point at the desktop and click with the secondary button.

-
- 2 Click **Properties**, and then the **Settings** tab.
 - 3 Change the Colors option and click **OK**.

For more information, see Windows® Help.

A message tells you that there is a problem with your display settings and that the adapter type is incorrect or the current settings do not work with your hardware.

Reduce the size of the color palette to one that is supported by the computer's internal display.

To change the display properties:

- 1 Point at the desktop and click with the secondary button.
The Display Properties window appears.
- 2 Click **Properties**, then click the **Settings** tab.
- 3 Adjust the screen resolution and/or color quality.
- 4 Click **OK**.

The display mode is set to Simultaneous and the external display device does not work.

Make sure the external monitor is capable of displaying at resolutions of 800 x 600 or higher. Devices that do not support this resolution will only work in Internal/External mode.

Small bright dots appear on your TFT display when you turn on your computer.

Your display contains an extremely large number of thin-film transistors (TFT) and is manufactured using high-precision technology. The small bright dots that appear on your display are an intrinsic characteristic of the TFT manufacturing technology.

NOTE

Over a period of time, and depending on the usage of the computer, the brightness of the LCD Screen will deteriorate. This is an intrinsic characteristic of LCD technology.

Screen will dim when the computer is operated on battery power and you may not be able to increase the brightness of the screen.

Disk drive problems

Problems with the hard disk or with a diskette drive usually show up as an inability to access the disk or as sector errors. Sometimes a disk problem may cause one or more files to appear to have garbage in them. Typical disk problems are:

You are having trouble accessing a disk, or one or more files appear to be missing.

Make sure you are identifying the drive by its correct name (A: or C:).

Error-checking

Run Error-checking, which analyzes the directories, files, and File Allocation Table (FAT) on the disk and repairs any damage it finds:

To run Error-checking:

- 1 Click **Start**, then click **My Computer**.
- 2 Right-click the drive you want to check and select **Properties** from the menu.

The drive's properties box appears.

- 3 Click the **Tools** tab.
- 4 Click the **Check now** button.

The Check Disk All Apps box appears.

-
- 5** You can choose one or both options:
 - ❖ Automatically fix file system errors
 - ❖ Scan for and attempt recovery of bad sectors
 - 6** Click **Start**.

Error-checking runs the test.

Your hard disk seems very slow.

If you have been using your computer for some time, your files may have become fragmented. Run Disk Defragmenter. To do this, click **Start**, then click **All Programs**, point to **Accessories** and **System Tools**, and click **Disk Defragmenter**.

Your data files are damaged or corrupted.

Refer to your software documentation for file recovery procedures. Many software packages automatically create backup files.

You may also be able to recover lost data using utility software, which is available from your dealer.

Some programs run correctly but others do not.

This is probably a configuration problem. If a program does not run properly, refer to its documentation and check that the hardware configuration meets its needs.

A diskette will not go into the external diskette drive.

You may already have a diskette in the drive. Make sure the drive is empty.

You may be inserting the diskette incorrectly. Hold the diskette with the hub side facing down, and insert it so that the metal head window cover goes into the drive first.

The metal cover or a loose label may be obstructing the path into the drive. Carefully inspect the diskette. If the metal cover is loose, replace the diskette. If the label is loose, replace the label and try inserting the diskette again.

The computer displays the message. Non-system disk or disk error

If you are starting the computer from a diskette, the diskette in the drive does not have the files necessary to start the computer. Replace it with a bootable diskette.

The drive cannot read a diskette.

Try another diskette. If you can access the second diskette, the first diskette (not the drive) is probably causing the problem. Run Error-checking on the faulty diskette (for instructions, see [“Disk drive problems” on page 200](#)).

DVD-ROM or multi-function drive problems**You cannot access a disc in the drive.**

Make sure the drive tray has closed properly. Press gently until it clicks into place.

Open the drive tray and remove the disc. Make sure the drive tray is clean. Any dirt or foreign object can interfere with the laser beam.

Examine the disc to see whether it is dirty. If necessary, wipe it with a clean damp cloth dipped in water or a neutral cleaner.

Replace the disc in the tray. Make sure it is lying flat, label side uppermost. Press the disc down until it locks on the spindle. Close the drive tray carefully, making sure it has shut completely.

You press the disc eject button, but the drive tray does not slide out.

Make sure the computer is connected to a power source and turned on. The DVD-ROM or multi-function drive eject mechanism requires power to operate.

To remove a disc without turning on the computer, use a narrow object, such as a straightened paper clip, to press the

manual eject button. This button is in the small hole next to the disc eject button on the right side of the computer.

Some discs run correctly, but others do not.

If the problem is with an application CD-ROM, refer to the software's documentation and check that the hardware configuration meets the program's needs.

Sound system problems

You do not hear any sound from the computer.

Adjust the volume control.

If you are using external headphones or speakers, check that they are securely connected to your computer.

The computer emits a loud, high-pitched noise.

This is feedback between the microphone and the speakers. It occurs in any sound system when input from a microphone is fed to the speakers and the speaker volume is too loud. Adjust the volume control.

Changing the settings for the Record Monitor feature in the Recording Control Utility (default Off), or the Mute feature in the Mixer Utility (default Enabled), may cause feedback. Revert to the default settings.

PC Card problems

PC Cards (PCMCIA-compatible) include many types of devices, such as a removable hard disk, additional memory, or a pager.

Most PC Card problems occur during installation and setup of new cards. If you are having trouble getting one or more of these devices to work together, several sections in this chapter may apply.

Resource conflicts can cause problems when using PC Cards. See [“Using PC Cards” on page 101](#) for more information.

Card Information Structure

When you insert a PC Card into a slot, the computer attempts to determine the type of card and the resources it requires by reading its Card Information Structure (CIS). Sometimes the CIS contains enough information for you to use the card immediately.

Other cards must be set up before you can use them. Use the Windows® XP PC Card (PCMCIA) Wizard to set up the card. Refer to your Microsoft® documentation for more information, or refer to the documentation that came with the PC Card.

Some card manufacturers use special software called *enablers* to support their cards. Enablers result in nonstandard configurations that can cause problems when installing the PC Card.

If your system does not have built-in drivers for your PC Card and the card did not come with an operating system driver, it may not work under the operating system. Contact the manufacturer of the PC Card for information about using the card under the operating system.

PC Card checklist

- ❖ Make sure the card is inserted properly into the slot.
See “Using PC Cards” on page 101 for information about how to insert PC Cards.
- ❖ Make sure all cables are securely connected.
- ❖ Occasionally a defective PC Card slips through quality control. If another PCMCIA-equipped computer is available, try the card in that machine. If the card malfunctions again, it may be defective.

Resolving PC Card problems

Here are some common problems and their solutions:

The slots appear to be dead. PC Cards that used to work no longer work.

Check the PC Card status:

- 1 Click **Start**.
- 2 Click **My Computer** icon with the secondary button, then click **Properties**.

The System Properties dialog box appears.

- 3 Click the **Hardware** tab.
- 4 Click the **Device Manager** button.
- 5 Double-click the **PCMCIA adapter**.
- 6 Double-click the appropriate PC Card.

The operating system displays your PC Card's Properties dialog box, which contains information about your PC Card configuration and status.

The computer stops working (hangs) when you insert a PC Card.

The problem may be caused by an I/O (input/output) conflict between the PCMCIA socket and another device in the system. Use Device Manager to make sure each device has its own I/O base address. See [“Fixing a problem with Device Manager” on page 193](#) for more information.

Since all PC Cards share the same socket, each card is not required to have its own address.

Hot swapping (removing one PC Card and inserting another without turning the computer off) fails.

Follow this procedure before you remove a PC Card:

- 1 Double-click the **PC Card** icon on the taskbar.

- 2 Click **Safely remove xxxx**, where *xxxx* is the identifier for your PC Card.

The operating system displays a message that you may safely remove the card.

- 3 Remove the card from the slot.

The system does not recognize your PC Card.

Refer to the PC Card documentation.

Removing a malfunctioning card and reinstalling it can correct many problems.

A PC Card error occurs.

Reinsert the card to make sure it is properly connected.

If the card is attached to an external device, check that the connection is secure.

Refer to the card's documentation, which should contain a troubleshooting section.

Printer problems

This section lists some of the most common printer problems:

The printer will not print.

Check that the printer is connected to a working power outlet, turned on, and ready (online).

Check that the printer has plenty of paper. Some printers will not start printing when there are just two or three sheets of paper left in the tray.

Make sure the printer cable is firmly attached to the computer and the printer.

Run the printer's self-test to check for any problem with the printer itself.

Make sure you installed the proper printer drivers, as shown in [“Setting up your printer” on page 133](#).

You may have connected the printer while the computer is on. Disable Stand By mode, turn off the computer, and turn off the printer. Turn the printer back on, make sure it is on line, then turn the computer back on.

Try printing another file. For example, you could create and attempt to print a short test file using Notepad. If a Notepad file prints correctly, the problem may be in your original file.

If you cannot resolve the problem, contact the printer's manufacturer.

The printer will not print what you see on the screen.

Many programs display information on the screen differently from the way they print it. See if your program has a print preview mode. This mode lets you see your work exactly as it will print. Contact the software manufacturer for more information.

Modem problems

This section lists common modem problems:

The modem will not receive or transmit properly.

Make sure the cable from the modem to the telephone line is firmly connected to the computer's modem port and the telephone line jack.

Check the port settings to make sure the hardware and software are referring to the same COM port.

Check the communications parameters (baud rate, parity, data length and stop bits) specified in the communications program. It should be set up to transmit at 300, 1200, 2400, 4800, 9600, 14400, 28800, 33600 bps (bits per second) or higher. Refer to the program's documentation and the modem manual for information on how to change these settings.

The modem is on, set up properly and still will not transmit or receive data.

Make sure the line has a dial tone. Connect a telephone handset to the line to check this.

The other system may be busy or off line. Try making a test transmission to someone else.

Develop good computing habits

Make sure you are prepared.

Save your work frequently.

You can never predict when your computer will lock, forcing you to close a program and lose unsaved changes. Many software programs build in an automatic backup, but you should not rely solely on this feature. Save your work! See [“Computing tips” on page 83](#) for instructions.

On a regular basis, back up the information stored on your hard disk.

Here are some ways you can do this:

- ❖ Copy files to CD/DVD or diskette, following the steps in [“Saving your work” on page 93](#).
- ❖ Connect a tape drive to the system and use specialized software to copy everything on the hard disk to a tape.

Some people use a combination of these methods, backing up all files to tape weekly and copying critical files to the media of their choice on a daily basis.

If you have installed your own programs, you should back up these programs as well as your data files. If something goes wrong that requires you to reformat your hard disk and start again, reloading all your programs and data files from a backup source will save time.

Read the user's guides.

It is very difficult to provide a fail-safe set of steps you can follow every time you experience a problem with the computer. Your ability to solve problems will improve as you learn about how the computer and its software work together.

Get familiar with all the user's guides provided with your computer, as well as the manuals that come with the programs and devices you purchase.

Your local computer store or book store sells a variety of self-help books you can use to supplement the information in the manuals.

If you need further assistance

If you have followed the recommendations in this chapter and are still having problems, you may need additional technical assistance. This section contains the steps to take to ask for help.

Before you call

Since some problems may be related to the operating system or the program you are using, it is important to investigate other sources of assistance first.

Try the following before contacting Toshiba:

- ❖ Review the troubleshooting information in your operating system documentation.
- ❖ If the problem occurs while you are running a program, consult the program's documentation for troubleshooting suggestions. Contact the software company's technical support group for their assistance.
- ❖ Consult the dealer from whom you purchased your computer and/or program. Your dealer is your best source for current information.

Detailed system specifications are available at www.ts.toshiba.com by selecting your particular product and model number, clicking **GO**, and then clicking the **Detailed Specs** link from the menu on the left, or just refer to the computer documentation shipped with your product.

For the number of a Toshiba dealer near you in the United States, call: (800) 457-7777.

Contacting Toshiba

If you still need help and suspect that the problem is hardware-related, Toshiba offers a variety of resources to help you.

To stay current on the most recent software and hardware options for your computer, and for other product information, be sure to regularly check the Toshiba Web site at pcsupport.toshiba.com.

Toshiba voice contact

Before calling Toshiba, make sure you have:

- ❖ Your computer's serial number.
- ❖ The computer and any optional devices related to the problem.
- ❖ Backup copies of your Windows operating system and all other preloaded software on your choice of media.
- ❖ Name and version of the program involved in the problem along with its installation media.
- ❖ Information about what you were doing when the problem occurred.
- ❖ Exact error messages and when they occurred.

For technical support, call the Toshiba Global Support Centre:

Within the United States at (800) 457-7777

Outside the United States at (949) 859-4273

Other Toshiba Internet Web sites

toshiba.com	Worldwide Toshiba corporate site
computers.toshiba.com	Marketing and product information in the USA
www.toshiba.ca	Canada
www.toshiba-Europe.com	Europe
www.toshiba.co.jp/index.htm	Japan
http://servicio.toshiba.com	Mexico and all of Latin America

Toshiba's worldwide offices

Australia

Toshiba (Australia) Pty. Limited
84-92 Talavera Road
North Ryde NSW 2113
Sydney
Australia

France

Toshiba Systèmes (France) S.A.
7, Rue Ampère; B. P. 131
92800 Puteaux Cédex
France

Italy

Centro Direzionale Colleoni
Palazzo Perseo
Via Paracelso 10
20041, Agrate Brianza
Milano, Italy

Canada

Toshiba Canada Ltd.
191 McNabb Street
Markham, Ontario
L3R - 8H2
Canada

Germany

Toshiba Europe GmbH
Leibnizstraße 2
D-93055 Regensburg
Germany

Japan

Toshiba Corporation, PCO-IO
1-1, Shibaura 1-Chome
Minato-Ku, Tokyo, 105-8001
Japan

Latin America and Caribbean

Toshiba America Information
Systems
9740 Irvine Blvd.
Irvine, California 92618
USA

800-457-7777 (within the US)

949-859-4273 (outside of the US -
this call may incur long-distance
charges)

Spain

Toshiba Information Systems
(España) S.A.
Parque Empresarial San Fernando
Edificio Europa, 1a Planta
Escalera A
28831 (Madrid) San Fernando de
Henares
Spain

United States

Toshiba America Information
Systems, Inc.
9740 Irvine Boulevard
Irvine, California 92618
United States

Mexico

Toshiba de México S.A. de C.V.
Sierra Candela No.111, 6to. Piso
Col. Lomas de Chapultepec.
CP 11000 Mexico, DF.

United Kingdom

Toshiba Information Systems
(U.K.) Ltd.
Toshiba Court
Weybridge Business Park
Addlestone Road
Weybridge, Surrey KT15 2UL
United Kingdom

The Rest of Europe

Toshiba Europe (I.E.) GmbH
Hammfelddamm 8
D-4-1460 Neuss
Germany

For more information on additional Toshiba worldwide
locations, please visit: www.toshiba.co.jp/index.htm.

Appendix A

Hot Keys

Hot keys are keys that, when pressed in combination with the Fn key, turn system functions on and off. Hot keys have a legend on or above the key indicating the option or feature the key controls.

Volume Mute

Fn +



This hot key enables/disables volume mute on your computer.



When volume mute is enabled, no sound will come from the speakers or headphones.



Instant password security

Fn +  This hot key blanks the display.

When the display re-appears, select your user name and enter the correct password if you have created one.

Power usage profile

Fn +  This hot key displays the power usage pop-up window and cycles through the profiles.

The power usage profiles are:

Full Power, High Power, Normal, DVD Playback, Presentation, and Long Life.

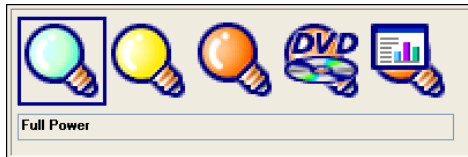

Sample power usage modes

The properties of each mode are set in the Toshiba Power Management utility. For more information, see [“Mobile Computing”](#) on page 114.

Stand By mode



This hot key puts the computer into Stand By mode.

A message box is displayed by default to confirm that the computer is going into Stand By mode. This message box can be set so it does not display.

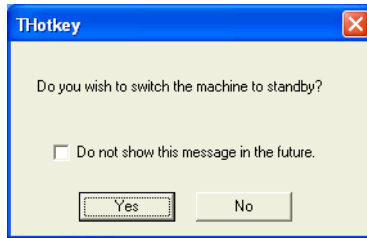

Sample Stand By confirmation box

For more information about Stand By mode, please see [“Using Standby” on page 111.](#)

Hibernation mode

Fn +



This hot key puts the computer into Hibernation mode.

If Hibernation mode is enabled (the default), a message box is displayed by default to confirm the computer is going into Hibernation mode. The message box can be set so it does not display.

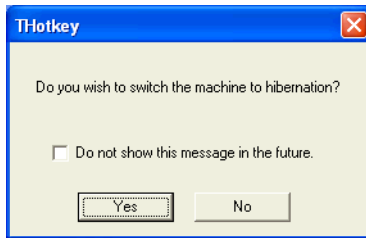

Sample Hibernation confirmation box

If Hibernation mode is disabled, this hot key will not respond. For more information on Hibernation mode, see [“Enabling Hibernation”](#) on page 173.

Display modes

Fn +



This hot key cycles through the power-on display options.

The display modes are:

- ❖ Built-in display panel only
- ❖ Built-in display panel and external monitor simultaneously
- ❖ External monitor only



Sample display options window

In order to use a simultaneous mode, you must set the resolution of the internal display panel to match the resolution of the external display device.

Display brightness



This hot key decreases the screen brightness.

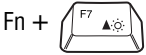

This hot key increases the screen brightness.



Disabling or enabling the TouchPad

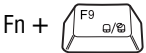

This hot key enables/disables the TouchPad.

To use the TouchPad, see [“Disabling or enabling the TouchPad”](#) on page 73.



Sample disable and enable TouchPad windows

Keyboard hot keys

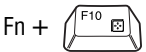

This hot key turns the cursor control overlay on and off.

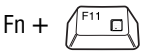

This hot key turns the numeric overlay on and off.



This hot key turns the scroll lock feature on and off.

Appendix B

Power Cord/Cable Connectors

The computer features a universal power supply you can use worldwide. This appendix shows the shapes of the typical AC power cord/cable connectors for various parts of the world.

USA and Canada



UL approved
CSA approved

Australia



AS approved

United Kingdom

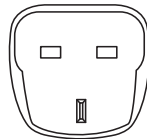

BS approved

Europe



VDA approved
NEMKO approved

Appendix C

Using ConfigFree™ with your Toshiba Computer

ConfigFree™ is a set of utilities that makes it easy to control communication devices and network connections. ConfigFree also lets you identify communication problems and create profiles for easy switching between locations and communication networks.

The ConfigFree utilities include the following:

- ❖ **Connectivity Doctor**—The Connectivity Doctor utility is used to analyze network connections and fix networking problems with your notebook computer. For more information, see [“Connectivity Doctor” on page 222](#).
- ❖ **Search for Wireless Devices**—The Search for Wireless Devices utility searches for wireless LAN and Bluetooth devices used in the neighborhood, and displays information about them on a virtual map. For more information, see [“Search for Wireless Devices” on page 225](#).
- ❖ **Profile Settings**—The Profiles utility lets you switch between network configurations. For more information, see [“Profile Settings” on page 227](#).



Getting Started

This section contains information about the ConfigFree main screen, and how to start and setup ConfigFree.

For more detailed information on setting up and using ConfigFree, see the Help File included in the application.

Starting ConfigFree

To start ConfigFree, be sure the computer has a wired or wireless connection. Then perform any of the following steps:

- ❖ (Microsoft® Windows® XP or 2000) Click the **Start** button, and select **All Programs, TOSHIBA, Networking, ConfigFree**.
- ❖ Double-click the **ConfigFree** icon  on the taskbar.
- ❖ Press the **Toshiba Console** button (if applicable to your system) to open the Toshiba Console, and then click the **ConfigFree** icon.
- ❖ Click the **ConfigFree** icon  on the taskbar, and then click the desired utility.

NOTE

If your computer is not connected to a network, the ConfigFree icon on the taskbar is displayed with an "X."

When you start a search for wireless devices, ConfigFree Launcher displays on your computer desktop. You can then click the appropriate icon on the Launcher to start the desired ConfigFree utilities.

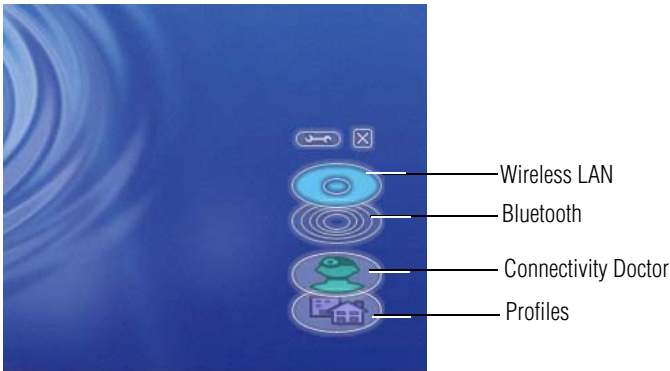

Sample ConfigFree Launcher

ConfigFree Utilities

Connectivity Doctor

The Connectivity Doctor lets you analyze your network connections and fix network-connection problems. Using Connectivity Doctor, you can view detailed network information by simply moving the mouse pointer.

The Connectivity Doctor works with the following network devices:

- ❖ Wired and wireless network devices
- ❖ Routers, hubs, and bridges
- ❖ Access points

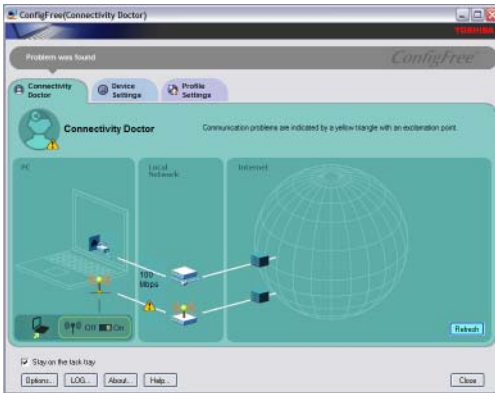

Sample Connectivity Doctor screen

Moving the mouse pointer over a wired or wireless network device icon displays information about the device, such as its IP address, subnet mask, and MAC address. A wireless network device also shows information such as the network SSID and the device's Wired Equivalent Privacy (WEP) key settings.

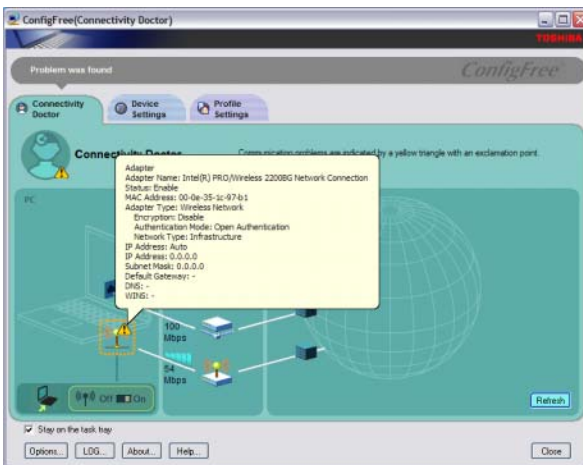

Sample viewing device information

If a problem, or potential problem, is detected, a triangle containing an exclamation point appears in the Connectivity Doctor screen and an orange frame describes the relevant location. You can then view a possible cause and solution for the problem by clicking the exclamation point.

For example, if the connection to a wireless network cannot be established because the wireless communication switch is turned off, an exclamation point appears next to the wireless communication switch. Clicking the exclamation point displays a description of the problem and a solution.

The following checkboxes and buttons are provided on the Connectivity Doctor screen:

Stay on the task tray	When checked, the ConfigFree icon resides in the system tray.
Options	Displays ConfigFree setting screen.
Log	Lets you create a diagnostic log, view a history of log files, or delete the history. Log files are saved as CFhtmlxxxx.htm, where xxxx is the creation date and time. They reside in the folder: C:\Documents and Settings\username\Local Settings\Temp
About	Displays the version of Connectivity Doctor.
Help	Displays online help.
Close	Closes the Connectivity Doctor screen.

Search for Wireless Devices

The Search for Wireless Devices utility searches for wireless LAN devices and Bluetooth devices currently used in the neighborhood, and displays information about them on a virtual map.

To search for wireless devices:

- 1 Click the  icon in the system tray.
- 2 Click **Search for Wireless Devices**.

A virtual map appears with a graphical representation of the wireless devices that have been detected.

NOTE Search for Wireless Devices can also be started from the ConfigFree Launcher.

For Wi-Fi networks, the intensity of a signal is displayed in five levels or “bands.” The signal from the connected access point is displayed in the bands surrounding the PC icon at the center of the map. Placing the pointer over the displayed “point of light” shows detailed information about the wireless device.

NOTE The wireless device shown near the center of the map is not necessarily near your notebook computer. If a wireless device located a distance away also has a strong signal, it appears near the center of the map as well.



Sample viewing Wi-Fi devices

The following screen shows an example of Bluetooth devices that are detected. As with the Wi-Fi screen, moving the mouse pointer over a device icon displays information about the device.

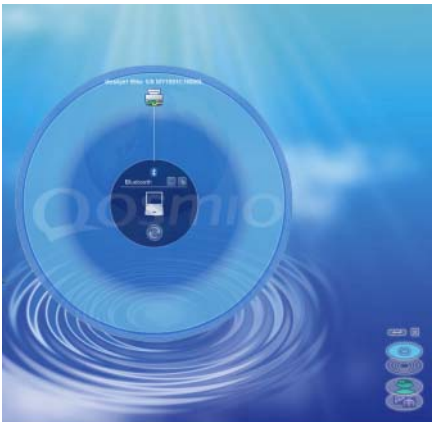

Sample viewing Bluetooth devices

You can connect to devices shown on the Bluetooth map:

- 1** Click the icon of a Bluetooth device.

- 2 Click your own computer at the center of the map.
- 3 Configured devices are automatically connected. Devices not yet configured launch the Add New Connection Wizard, where you can configure and connect to the device.

Profile Settings

The Profile Settings utility lets you save network settings in “profiles.” ConfigFree profiles are useful for easily switching network settings and devices. You can switch network settings simply by selecting the profile with the desired settings.

If you visit a client company occasionally, for example, you can set up a profile to match that environment and connect to the network. Similarly, users who access networks in the office and at home can set up profiles to handle these networking environments.

A profile contains the currently configured network settings on the computer, as well as information about any network devices. The following settings can be saved (or “captured”) in a profile:

- ❖ **Internet settings** — includes LAN settings (proxy server settings) and the address of a home page that opens automatically when Internet Explorer starts.
- ❖ **Devices** — lets you enable or disable settings of wired and wireless network devices, infrared devices, and set the power status of Bluetooth antennas.
- ❖ **TCP/IP settings** — includes DHCP, IP address, subnet mask, default gateway, DNS server, and WINS server settings.

- ❖ Personal firewall settings for Internet connections.
- ❖ Dial-up connection settings for the default connection.
- ❖ File and printer sharing settings.
- ❖ Printer settings for the default printer.

To create a profile:

- 1 Click the  icon in the system tray.
- 2 Move the pointer to **Profile**.
- 3 Click **Add**. The Add Profile screen appears.
- 4 Select **Capture** and click **OK**. The Add Profile screen appears.
- 5 Enter the name of the profile you want to create.
- 6 Enter any optional comments, if desired.
- 7 Click **Change Icon** and select an icon for this profile.
- 8 Under **Captured Items**, select the items you want to capture for this profile.
- 9 If connecting with a wireless network, select the desired **Auto Switch Settings**. (These options are unavailable if wireless devices have been disabled.)
- 10 Under **Execute this program after switching**, click the **Browse** button and select the program, file, or Web site URL that is to start after switching to this profile.

For example to have Internet Explorer start in Windows XP after switching profiles, type:

C:\Program Files\Internet Explorer\IEXPLORE.EXE

- 11 Click **OK**.

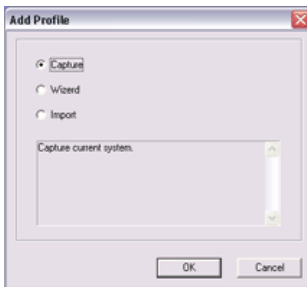

Sample Add Profile screen

NOTE

The online help provides real-world examples of setting up profiles for different networking environments.

After you set up one or more profiles, you can check their settings and fine-tune them as necessary. Profiles can also be imported and exported. This feature is useful when transferring profile settings to other computers. For more information about modifying, importing, and exporting profiles, refer to the online help.

Quick Connect

The Quick Connect feature switches the Wireless LAN connection to connect to a Toshiba Wireless Projector. Once the projector utility is installed, launching the Quick Connect utility automatically opens the Wireless Data Projector Application. There you can configure how you would like to use the projector.

To connect to a Toshiba Wireless Projector:

- 1 Click the  icon in the system tray.
- 2 Move the mouse pointer to **Toshiba Wireless Projector (DPJ)**, then click **Connect**.

Launching Quick Connect prevents you from using the network to connect to a Toshiba Wireless Projector when the wireless LAN Configuration is set to Ad hoc. If you are connected to an access point, the connection is broken and re-established later.

To review the current Toshiba Wireless Projector settings and change them if necessary:

- 1 Click the  icon in the system tray.
- 2 Move the mouse pointer to **Toshiba Wireless Projector (DPJ)**, then click **Settings**. The Quick Connect properties dialog box appears.
- 3 Complete the settings. Refer to the online help if necessary.
- 4 Click **OK**.

NOTE

The default connection setting is for Ad hoc mode, therefore, if the setting on the Toshiba Wireless Projector is in Infrastructure mode, it will not connect, however; you can change the settings to Infrastructure mode to match the settings on the projector.



Sample Projector icon when connected with Quick Connect

If the wireless mode for the wireless setting is set for 5 GHz (802.11a), Quick Connect changes this mode to 2.4 GHz (802.11b) and then connects to the projector.

The wireless LAN configuration returns to the settings that were last used before the Quick Connect function was started:

- ❖ If the Toshiba Wireless Projector utility is closed.
- ❖ If you select Toshiba Wireless Projector (DPJ) from the ConfigFree tray menu (this disconnects the wireless LAN connection).
- ❖ If you select a profile from the ConfigFree tray menu or when you disable a wireless device.
- ❖ If you close ConfigFree.

Using the Automatic Switch

The Automatic Switch feature allows the computer to automatically switch profiles the next time it is powered on. This feature is particularly useful if you want your computer to automatically switch from the network configuration you use in your office to the one you use at home.

The Auto Switch feature contains options for automatically switching between wired and wireless devices. With these options, the computer automatically switches to a wireless LAN network when the cable of the wired LAN network is removed from the computer. When the cable is reconnected, the connection to the wired LAN is re-established.

To use the Automatic Switch feature:

- 1 Right-click the  icon in the system tray.
- 2 Click **Auto Switch**. The Auto Switch dialog box appears.
- 3 Check **Enable Wireless when cable disconnect occurs**.
- 4 Click **OK**.

NOTE

If your computer is connected to multiple wireless LAN devices, the Auto Switch (SSID) feature is disabled. To enable this feature, only one wireless LAN device can be used.

Semi-Automatic Switch Feature

The Semi-Automatic feature alerts you when the computer connects to a Service Set Identifier (SSID) stored in a profile. When the computer connects to the designated SSID, a notification window appears. You can then click this window to connect using the settings specified in the profile.

To use the Semi-Automatic Switch feature:

- 1 Right-click the  icon in the system tray.
- 2 Click **Auto Switch**. The Auto Switch dialog box appears.
- 3 Select the **Auto Switch (SSID)** tab.
- 4 Select the profile to be automatically selected when the SSID is detected, then click **Add**. The profile is moved to the **List of target SSIDs and profiles**.
- 5 Repeat the previous step for each additional profile you want to select.
- 6 Select **Automatically switch profiles when connected to this SSID**.
- 7 Check **Automatically switch profile when connected to this SSID**.
- 8 Click **OK**.

The computer is now configured to use the Semi-Automatic Switch feature. When the computer connects to an SSID in a profile, a display notification window appears. You can then click **Switch** on the window to switch profiles. You can also set the option for having the switch be automatic without the need for a notification.

NOTE

Several profiles can be defined for a single SSID. In this case, several notification windows are displayed. By clicking these windows, you can switch to the profile for that location.

Glossary



TECHNICAL NOTE: Some features defined in this glossary may not be available on your computer.

Acronyms

These acronyms may appear in this user's guide.

AC	alternating current
BIOS	basic input/output system
bps	bits per second
CD	compact disc
CD-ROM	compact disc read-only memory
CD-RW	compact disc rewrite memory
CMOS	complementary metal-oxide semiconductor
COM1	communications port 1 (serial port)
COM2	communications port 2 (serial port)
CPU	central processing unit

DC	direct current
DMA	direct memory access
DIMM	dual inline memory module
DOS	disk operating system
DPI	dots per inch
DSTN	dual supertwist nematic
DVD	digital versatile (or video) disc
DVD-ROM	digital versatile (or video) disc read-only memory
ECP	enhanced capabilities port
EPROM	erasable programmable read-only memory
FAT	file allocation table
FCC	Federal Communications Commission
GB	gigabyte
HDD	hard disk drive
HTML	Hypertext Markup Language
IEEE	Institute of Electrical and Electronics Engineers
I/O	input/output
IRQ	interrupt request
ISP	Internet service provider
KB	kilobyte
LAN	local area network
LCD	liquid crystal display
LPT1	line printer port 1 (parallel port)
LSI	large-scale integration
MB	megabyte
MIDI	Musical Instrument Digital Interface
PC	personal computer
PCI	Peripheral Component Interconnect
PCMCIA	Personal Computer Memory Card International Association

RAM	random access memory
RFI	radio frequency interference
ROM	read-only memory
RTC	real-time clock
SCSI	small computer system interface
DDRAM	double data random access memory
SRAM	static random access memory
SVGA	super video graphics adapter
TFT	thin film transistor
USB	universal serial bus
URL	uniform resource locator
WAN	wide area network
www	World Wide Web

Terms

These terms may appear in this user's guide.

A

active-matrix display — A liquid crystal display (LCD) made from an array of liquid crystal cells using active-matrix technology. Also known as a “TFT display,” in its simplest form there is one thin film transistor (TFT) for each cell. This type of display works well with notebook computers because of its shallow depth and high-quality color. Active-matrix displays are viewable from wider angles than most passive-matrix displays.

adapter — A device that provides a compatible connection between two units. For example, the computer's internal display adapter receives information from the software and translates it into images on the screen. An adapter can take a number of forms, from a microprocessor to a simple connector. An intelligent adapter (one that is capable of doing some processing) may also be called a controller.

alternating current (AC) — The type of power usually supplied to residential and commercial wall outlets. AC reverses its direction at regular intervals. Compare *direct current (DC)*.

application — A computer program that you use to perform tasks of a specific type. Applications include word processors, spreadsheets, and database management systems. See also *program*.

B

backup — A copy of a file, usually on a removable disk, kept in case the original file is lost or damaged.

basic input/output system (BIOS) — See *BIOS*.

baud rate — The speed at which a communication device, such as a printer or modem, transmits information. Baud rate is the number of signal changes per second (not necessarily the same as bits per second). See also *bits per second*.

BIOS (basic input/output system) — Basic instructions, stored in read-only memory (ROM), containing the information the computer needs in order to check hardware and load the operating system when you start up the computer.

bit: — Short for “binary digit.” A bit is the smallest unit of information used by a computer. A group of eight bits is a byte. See also *byte*.

bits per second (bps) — A way of measuring the speed at which information is passed between two devices. The basic measure used in modem communications, bps is similar, but not identical, to the baud rate. See also *baud rate*.

boot — To start the computer. The term “boot” originates from bootstrap program (as in “pulling itself up by its bootstraps”), a program that loads and initializes the operating system. See also *reboot*.

boot disk — See *system disk*.

boot priority (startup sequence) — The order in which the computer accesses its disk drives to locate the startup files. Under the default startup sequence, the computer looks for the startup files in the diskette drive before checking the hard disk.

bus — An electrical circuit that connects the central processing unit (CPU) with other parts of the computer, such as the video adapter, disk drives, and ports. It is the pathway through which data flows from one device to another. See also *bus speed*, *frontside bus*.

bus speed — The speed at which the central processing unit (CPU) communicates with the other parts of the computer.

byte — A sequence of eight bits. A byte is the smallest addressable unit of data. See also *bit*, *gigabyte*, *kilobyte*, *megabyte*.

C

cache — A section of very fast memory in which frequently used information is duplicated for quick access. Accessing data from cache is faster than accessing it from the computer's main memory. See also *CPU cache*, *L1 cache*, *L2 cache*.

CD — An individual compact disc. See also *CD-ROM*.

CD-ROM (compact disc read-only memory) — A form of high-capacity storage that uses laser optics instead of magnetic means for reading data. See also *CD*. Compare *DVD-ROM*.

central processing unit (CPU) — The chip that functions as the “brain” of the computer. It takes information from outside sources, such as memory or keyboard input, processes the information, and sends the results to another device that uses the information.

character — Any letter, number, or symbol you can use on the computer. Some characters are non-printing characters, such as a paragraph break in a word-processing program. A character occupies one byte of computer storage.

chip — A small piece of silicon containing computer logic and circuits for processing, memory, input/output, and/or control functions. Chips are mounted on printed circuit boards.

click — To press and release the TouchPad control button or mouse button without moving the cursor or mouse. In the Windows® operating system, this refers to the left mouse button or primary TouchPad control button, unless otherwise stated. See also *double-click*.

color palette — A set of specified colors that establishes the colors that can be displayed on the screen at a particular time.

compatibility — The extent to which computers, programs, or devices can work together harmoniously, using the same commands, formats, or language as another.

configuration — (1) The collection of components that make up a single computer system. (2) How parts of the system are set up (that is, configured).

controller — A device that controls the transfer of data from a computer to a peripheral device and vice versa. For example, disk drives, monitors, keyboards, and printers all require controllers.

CPU — See *central processing unit (CPU)*.

CPU cache — A section of very fast memory residing between the CPU and the computer's main memory that temporarily stores data and instructions the CPU will need to execute commands and programs. See also *cache, L1 cache, L2 cache*.

cursor — A symbol that indicates the current position on the screen. The shape of the cursor varies, depending on the program you are using and what you are doing.

D

default — The setting selected by a program when the user does not specify an alternative setting.

device — A component attached to the computer. Devices may be external (outside the computer's case) or internal (inside the computer's case). Printers, disk drives, and modems are examples of devices.

device driver — A program (called a "driver") that permits a computer to communicate with a device.

dialog box — An on-screen window displayed by the operating system or a program giving a direction or requesting input from the user.

direct current (DC) — The type of power usually supplied by batteries. DC flows in one direction. Compare *alternating current (AC)*.

direct memory access (DMA) — A dedicated channel, bypassing the CPU, that enables direct data transfer between memory and a device.

directory — See *folder*.

disable — To turn a computer option off. See also *enable*.

disc — A round, flat piece of metal, designed to be read from and written to by optical (laser) technology, and used in the production of optical discs, such as CDs and DVDs. Compare *disk*.

- disk** — A round, flat piece of material that can be magnetically influenced to hold information in digital form, and used in the production of magnetic disks, such as diskettes and hard disks. Compare *disc*. See also *diskette*, *hard disk*.
- disk drive** — The device that reads and writes information and programs on a diskette or hard disk. It rotates the disk at high speed past one or more read/write heads.
- diskette** — A thin, flexible disk in a protective jacket that stores magnetically encoded data. Diskettes can be removed from the computer and come in two sizes: 5.25-inch and 3.5-inch. Your computer uses 3.5-inch diskettes. See also *double-density diskette*, *high-density diskette*.
- document** — Any file created with an application and, if saved to disk, given a name by which it can be retrieved. See also *file*.
- double-click** — To press the TouchPad control button or mouse button rapidly twice without moving the cursor or mouse. In the Windows® operating system, this refers to the primary TouchPad control button or left mouse button, unless otherwise stated.
- double-density diskette** — A 3.5-inch diskette that can hold up to 720 KB of information (half the capacity of a high-density diskette). See also *diskette*, *high-density diskette*.
- download** — (1) In communications, to receive a file from another computer through a modem or network. (2) To send font data from the computer to a printer. See also *upload*.
- drag** — To hold down the TouchPad control button or mouse button while moving the cursor to drag a selected object. In the Windows® operating system, this refers to the primary TouchPad control button or left mouse button, unless otherwise stated.
- driver** — See *device driver*.
- DVD** — An individual digital versatile (or video) disc. See also *DVD-ROM*.

DVD-ROM (digital versatile [or video] disc read-only memory) — A very high-capacity storage medium that uses laser optics for reading data. Each DVD-ROM can hold as much data as several CD-ROMs. Compare *CD-ROM*.

E **emulation** — A technique in which a device or program imitates another device or program.

enable — To turn on a computer option. See also *disable*.

executable file — A computer program that is ready to run. Application programs and batch files are examples of executable files. Names of executable files usually end with a .bat or .exe extension.

expansion device — A device that connects to a computer to expand its capabilities. Other names for an expansion device are port expander, port replicator, docking station, or network adapter.

extension — See *file extension*.

external device — See *device*.

F **file** — A collection of related information, saved on disk with a unique name. A file may be a program, information used by a program, or a document. See also *document*.

file allocation table (FAT) — The section of a disk that keeps track of the location of files stored on the disk.

file name — A set of characters that uniquely identifies a file within a particular folder. It consists of two parts: the actual name and the file name extension. See also *file extension*.

file extension — The three characters following the period (pronounced “dot”) at the end of a file name. The extension indicates the type of file. Examples are .exe for program files and .hlp for help files. See also *file name*.

folder — Also called *directory*. A container for organizing files saved to a disk. A folder is symbolized on screen by a graphical image (icon) of a file folder. A folder can contain files and other folders.

format — (verb) To prepare a blank disk for use with the computer's operating system. Formatting creates a structure on the disk so the operating system can write information to the disk or read information from it.

frontside bus — The primary pathway (bus) between the CPU and the computer's main memory. Also called "system bus." See also *bus*.

function keys — The keys labeled F1 through F12, typically located on the keyboard. Their function is determined by the operating system and/or individual programs.

G

gigabyte (GB) — A unit of data equal to 1,073,741,824 bytes (1024 x 1024 x 1024 bytes). See also *byte*.

ground — A conductor to which all components of an electric circuit are connected. It has a potential of zero (0) volts, is connected to the earth, and is the point of reference for voltages in the circuit.

H

hard disk — A storage device composed of a rigid platter or platters that can be magnetically coded with data. Hard disks hold much more information than diskettes and are used for long-term storage of programs and data. The primary (or only) hard disk in a computer is usually fixed, but some computers have secondary hard disks that are removable. By default, the hard disk is referred to as drive C.

hardware — The physical components of a computer system. Compare *software*.

Hibernation — A feature of many Toshiba notebook computers that saves to the hard disk the current state of your work, including all open files and programs, when you turn the computer off. When you turn on the computer again, your work is returned to the same state it was when the computer was turned off. See also *Standby*, *Suspend*.

high-density diskette — A 3.5-inch diskette that holds 1.44 MB of data. See also *diskette*.

hot key — (1) A feature in which certain keys in combination with the Fn key can set system options or control system parameters, such as the battery save mode. (2) A key or combination of keys that activates a memory resident program.

hot swapping — The ability to add or remove devices from a computer while the computer is running and have the operating system automatically recognize the change.

icon — A small image displayed on the screen that represents a function, file, or program.

interlaced — A method of refreshing a computer screen, in which only every other line of pixels is refreshed. Interlaced monitors take two passes to create a complete screen image. Compare *non-interlaced*.

internal device — See *device*.

Internet — The decentralized, world-wide network of computers that provides electronic mail, the World Wide Web, and other services. See also *World Wide Web*.

keyboard shortcut — A key or combination of keys that you use to perform a task instead of using a pointing device such as the TouchPad.

kilobyte (KB) — A unit of data equal to 1024 bytes. See also *byte*.

L1 (level one) cache — Memory cache built into the processor to help improve processing speed. See also *cache, CPU cache, L2 cache*.

L2 (level two) cache — Memory cache installed on the motherboard to help improve processing speed. It is slower than L1 cache and faster than main memory. See also *cache, CPU cache, L1 cache*.

LAN (local area network) — A group of computers or other devices dispersed over a relatively limited area and connected by a communications link that enables any device to interact with any other on the network.

liquid crystal display (LCD) — A type of display that uses a liquid substance between two transparent electrode panels. When an electric current passes through the electrodes, the molecules in the liquid form a crystalline pattern that polarizes the light passing through it. A filter over the electrodes permits only non-polarized light to pass to the surface of the display, creating light and dark pixels.

load — To move information from a storage device (such as a hard disk) into memory for processing.

local area network — See *LAN*.

logical drive — A section of a disk that is recognized by the operating system as a separate disk drive. A system's logical drives may differ from its physical drives. For example, a single hard disk drive may be partitioned into two or more logical drives.

M

megabyte (MB) — A unit of data equal to 1,048,576 bytes (1024 x 1024 bytes). See also *bytes*.

memory — Typically refers to the computer's main memory, where programs are run and data is temporarily stored and processed. Memory can be volatile and hold data temporarily, such as RAM, or it can be nonvolatile and hold data permanently, such as ROM. A computer's main memory is RAM. See *RAM*, *ROM*.

microprocessor — See *central processing unit (CPU)*.

MIDI (Musical Instrument Digital Interface) — A standard for connecting musical instruments, synthesizers, and computers. The MIDI standard provides a way of translating music into a form computers can use, and vice versa.

modem — Short for “modulator/demodulator.” A device that converts information from digital to analog and back to digital, enabling information to pass back and forth between digital computers and analog telephone lines.

motherboard — The main circuit board in the computer. It contains the processor, memory, and other primary components.

MS-DOS® prompt — See *system prompt*.

multi-function drive — A DVD drive that can read and write to CD and DVD media.

multimedia — A combination of two or more media, such as sound, animation, and video in a computer program or presentation.

Musical Instrument Digital Interface — See *MIDI*.

N

network — A collection of computers and associated devices that are connected by communications facilities. A network allows you to share data and peripheral devices, such as printers, with other users and to exchange electronic mail.

non-interlaced — A method of refreshing a computer screen, in which each pixel of every line is refreshed as the electron beam scans across and down the screen. Compare *interlaced*.

non-system disk — A disk for storing programs and data that cannot be used to start the computer. Compare *system disk*.

O

online — Available through the computer. Online may refer to information being read from your own computer's hard disk, such as online documentation or online help, or to information coming from another company on a company network or the Internet.

operating system — A set of programs that controls how the computer works. Examples of operating systems are Windows® XP and Windows® 2000.

P

palette — See *color palette*.

parallel — Processes that occur simultaneously. In communications, it means the transmission of more than one bit of information at a time. On your computer, the parallel port provides a parallel communications interface between the computer and an appropriate device. Most modern printers are parallel. Compare *serial*.

password — A unique string of characters entered by a user to verify his or her identity to the computer or the network.

PC Card — A credit-card-sized expansion card designed to increase the capabilities of notebook computers. PC Cards provide functions such as modem, fax/modem, hard disk drive, network adapter, sound card, or SCSI adapter.

peripheral — Any device, such as a printer or joystick, that is attached to the computer and controlled by the computer's CPU.

pixel — Short for "picture element." The smallest dot that can be produced on a screen or printer.

Plug and Play — Generally, refers to the computer's ability to automatically configure itself to work with peripheral devices. When capitalized, refers to a standard that, when followed by a device manufacturer, allows a PC to configure itself automatically to work with the device.

pointing device — Any device, such as the TouchPad or a mouse, that enables you to move the cursor on the screen.

port — A socket on the computer where you plug in a cable for connection to a network or a peripheral device.

processor — See *central processing unit (CPU)*.

program — A set of instructions that can be executed by a computer. The general classes of programs (also called software) are operating system, application, and utility. See also *operating system, application, utility*.

properties — The attributes of an object or device. For example, the properties of a file include the file's type, size, and creation date.

R

RAM (random access memory) — Volatile memory that can be written to as well as read. By volatile, we mean that information in RAM is lost when you turn off your computer. This type of memory is used for your computer's main memory. See also *memory*. Compare *ROM*.

random access memory — See *RAM*.

read-only memory — See *ROM*.

reboot — See *boot, restart*.

removable disk — A disk that can be removed from a disk drive. A diskette is one example of a removable disk.

resolution — A measure of the sharpness of the images that can be produced by a printer or displayed on a screen. For a printer, resolution is expressed in dots per inch (dpi). For a screen, it is expressed as the number of pixels available horizontally and vertically.

restart — Synonymous with reboot. To reset the computer by reloading the operating system without turning the computer off. See also *boot*.

RJ-11 — A modular connector used on most U.S. telephone systems and direct-connect modems. The RJ-11 connector is a 6-wire connector.

ROM (read-only memory) — Non-volatile memory that can be read but not written to. By non-volatile, we mean that information in ROM remains whether or not the computer is receiving power. This type of memory is used to store your computer's BIOS, which is essential instructions the computer reads when you start it up. See also *BIOS, memory*. Compare *RAM*.

S

select — To highlight or otherwise specify text, data, or graphics with the intent to perform some operation on it.

serial — Processes that occur one at a time. In communications, it means the transmission of one bit at a time sequentially over a single channel. On your computer, the serial port provides a serial interface between the computer and an appropriate device. Compare *parallel*.

shortcut — See *keyboard shortcut*.

software — See *program*. Compare *hardware*.

Standby — A feature of some Windows® operating systems that allows you to turn off the computer without exiting your open applications and to continue from where you left off when you turn the computer on again.

Suspend — A feature of some Windows® operating systems that allows you to turn off the computer without exiting your open applications and to continue from where you left off when you turn the computer on again.

system disk — A diskette that contains the operating system files needed to start the computer. Any diskette can be formatted as a system disk. A system disk is also called a “bootable disk” or a “startup disk.” Compare *non-system disk*.

system prompt — The symbol (in MS-DOS®, generally a drive letter followed by a “greater than” sign) indicating where users are to enter commands.

T

TFT display — See *active-matrix display*.

U **universal serial bus (USB)** — A serial bus that supports a data transfer rate of up to 480 Mbps (480 million bits per second). USB can connect up to 127 peripheral devices through a single all-purpose USB port. USB allows hot swapping of peripherals. See also *bus*, *hot swapping*, *serial*.

upload — To send a file to another computer through a modem or network. See also *download*.

USB — See *universal serial bus (USB)*.

utility — A computer program designed to perform a narrowly focused operation or solve a specific problem. Utilities are often related to computer system management.

W **Web** — See *World Wide Web*.

Wi-Fi — A trademarked term by the Wireless Capability Ethernet Alliance which stands for Wireless Fidelity, and is another term for the communication protocol to permit an Ethernet connection using wireless communication components.

World Wide Web (www) — The worldwide network of Web sites linked together over the Internet. A user of the Web can jump from site to site regardless of the location of the computer hosting the site. See also *Internet*.

Index

Numerics

101-key keyboard 86

A

AC adapter 49

AC power cord/cable connectors
219

accessories

 carrying cases 104

 memory 55

Add Printer Wizard 133

adding memory 55

adjusting recording quality 153

Alt keys 86

arm/wrist strain 45

assign keys

 Fn-esse 163

audio

 .wav files 152

audio features 149

Auto-Run 151

B

backing up files 84

battery

 caring for 124

 changing 122

 charge does not last 196

 charging 52, 117

 charging before use 47

 conserving power 128

 disposal 127

 not charging 196

 power usage hot key 129

 power usage mode 214

 removing 123

 unlocking 123

battery alarms 121

battery power

 displaying remaining 119

 monitoring 119

button

 power 55, 63

 start 140

C

CD

- creating 151
- playing an audio 149
- playing using Auto-Run 151

CDs

- problem solving 203

channels

- DMA 192
- IRQ 192

character keys 85

charging

- main battery 117

charging the battery 52

checking device properties 194

click 73

communications

- network connection 143
- setting up 105
- system resources 192

compact disc positioning 99

compact discs

- handling 99
- inserting 98
- problem solving 203
- removing 100

computer

- customizing 166
- non-system disk or disk error message 188
- not accessing disk drives 187
- precautions 46
- setting up 57
- turning off 75
- warning resume failure message 188

computer placement 43

computer setup 47

computer-friendly environment 41

computing tips 83

connecting to a power source 49

connection

- set up 144

control buttons 73

critical applications 3

Ctrl keys 86

D

desktop

- creating new icon 139
- major features 139

desktop exploration 138

desktop icons 139

Device Manager 193

- checking properties 194
- disabling a device 193, 194

devices

- keyboard 78
- mouse 78

disable/enable

- TOSHIBA Touch and Launch 183

Disk Defragmenter 201

disk drive

- corrupted/damaged data files 201
- missing files/trouble accessing a disk 200
- running slow 201

diskette drive

- can not insert a diskette 201
- can't read a diskette 202
- connecting 81
- external, connecting 81

display

- does not look normal/flickers 198
- external monitor not working 199
- screen is blank 197

- display device
 - external 76
- display modes hot key 217
- display output settings 77
- display panel
 - closing 76
- display, external
 - adjusting 78
- disposal information 27
- disposing of used batteries 127
- DMA (Direct Memory Access) 192
- double-click 73
- DVD-ROM or multi-function drive
 - cannot access disc 202
- DVD-ROM/multi-function drive
 - drive tray will not open 202
 - problems 202
 - troubleshooting 194

E

- energy saving features 114
- ergonomics 44
- error messages
 - device driver conflict 191
 - general hardware problem 191
 - non-system disk or disk error 188, 202
 - problem with display settings/
 - current settings not working with hardware 199
 - program has performed an illegal operation 186
 - warning resume failure 188
- Error-checking 200
- Ethernet LAN port 144
- expansion capability 136
- expansion memory slot 57
- exploring the desktop 138
- external

- mouse 78
- external diskette drive
 - connecting 81
- external display, adjusting 78
- external monitor
 - not working 199
- external speakers 82

F

- FAT (File Allocation Table) 200
- FCC Notice “Declaration of Conformity Information” 3
- FCC requirements 4
- file extensions 95
- file names 94
- file, backing up 84
- files
 - backing up 104
 - printing 95
 - restoring 105
 - saving 93
- FN keys 86
- Fn-esse
 - starting 161
 - using to assign keys 163
- Fn-esse program 161
 - assigning a key 161
 - using drag-and-drop 162
- function keys 86

H

- hardware conflicts 191
 - resolving 192
- headphones
 - connecting 82
 - using 153
- Help
 - Windows XP 190
- Hibernation
 - enabling 166

- Hibernation mode 109
 - configuring 109
 - starting again from 110
 - Hibernation mode hot key 216
 - hot key
 - display modes 217
 - Hibernation mode 216
 - keyboard 218
 - keyboard overlays 218
 - power usage mode 214
 - Stand By mode 215
 - volume mute 213
 - hot key power usage mode 129
 - hot key utility 168, 169
 - hot keys 213
 - hot swapping
 - PC Cards 101
- I**
- icon 139
 - definition 39
 - desktop 139
 - hint 39
 - Internet Explorer 140
 - moving to desktop 139
 - recycle bin 140
 - safety 38
 - technical note 39
 - Industry Canada requirement 4
 - installation
 - memory module 56
 - installing
 - memory modules 55
 - mouse 78
 - instant passwords, using 175
 - Internal/External mode 199
 - Internet
 - bookmarked site not found 190
 - connecting to 147
 - features 148
 - slow connection 190
 - surfing 148
 - uploading and downloading files 149
 - URL address not found 190
 - Internet Explorer icon 140
 - Internet Service Providers 147
 - IRQ (Interrupt Request) 192
 - ISPs 147
- J**
- jack
 - RJ-11 159
- K**
- keeping comfortable 42
 - key
 - assign 163
 - changing 164
 - direct assign 163
 - popup 164
 - removing 164
 - key assignment
 - viewing existing 164
 - key assignments
 - changing or removing existing 164
 - keyboard
 - character keys 85
 - function keys 86
 - hot keys 218
 - not working 187, 197
 - overlay keys 87
 - unexpected characters 197
 - Windows special keys 87
 - keyboard, external 78
 - keyboard, full-size 86
 - keyboard, PS/2-compatible 78

L

LCD power-saver 76
lighting 44

M

memory
 adding 55
 expansion slots 56
 problem solving 195
 removing expansion slot cover
 57

memory module
 inserting 58
 installation 56
 removing 61

microphone 152
 external, connecting 82

Microsoft Support Online Web site
191

modem
 connecting to a telephone line
 158
 determining COM port 142
 problem solving 207, 208
 resetting port to default settings
 142
 upgrading 142

modules
 Wi-Fi Mini PC 136

monitor 76
 connecting 76
 not working 198

mouse
 installing 78
 serial 78
 using 132

N

network 166
 accessing 143

Dial-Up Networking Wizard
143

networking
 wireless 143

O

office computing 131
opening the display panel 53
optional devices 131
other documentation 39
overlay keys 87

P

password
 deleting a supervisor 177
 disabling a user 176
 supervisor
 set up 176

passwords
 instant, using 175
 setting user 174

PC Card
 checklist 204
 CIS (Card Information
 Structure) 204

configuring 158
errors 206
hot swapping 101
inserting 156
modem default 142
not recognized 206
problem solving 203, 205
removing 157
setting up 158
using 101

port
 COM 142
 Ethernet LAN 144
 RGB 76

posture 43

- power
 - alarms 121
 - computer will not start 187
 - options 130
 - problem solving 195
 - taking care of your battery 124
 - turning on 54
 - universal power supply 219
- power button 55, 63
- power mode
 - creating new 168
 - customizing 168
- power source 49
- power usage mode
 - hot key 129
- power usage mode hot key 214
- power usage modes 128
- powering down
 - using Standby 111
- precautions 46, 52
 - other computer use 46
- primary button 73
- printer
 - choosing a driver 133
 - local, connecting 79
 - problem solving 206, 207
 - set up 133
 - using 132
- printing a file 95
- problem solving
 - AC power 196
 - accessing disk drives 187
 - battery charge does not last 196
 - battery not charging 196
 - can not insert diskette in drive 201
 - can't read a diskette 202
 - cannot access DVD-ROM or multi-function drive 202
 - changing display properties 199
 - checking device properties 194
 - compact discs not running correctly 203
 - computer will not power up 187
 - contacting Toshiba 209, 210
 - corrupted/damaged data files 201
 - Device Manager 193
 - disabling a device 193, 194
 - disk drive is slow 201
 - display is blank 197
 - DVD-ROM/multi-function drive tray does not eject 202
 - external display not working 199
 - external keyboard not working 197
 - external monitor 198
 - faulty memory 195
 - hardware conflict 191, 192
 - high-pitched noise 203
 - illegal operation 186
 - Internet bookmarked site not found 190
 - Internet connection is slow 190
 - keyboard
 - not responding 187
 - keyboard produces unexpected characters 197
 - missing files/trouble accessing a disk 200
 - modem not receiving or transmitting 207, 208
 - no sound 203
 - non-system disk or disk error 188, 202
 - PC Card 203
 - checklist 204

- error occurs 206
 - not recognized 206
 - slots appear dead 205
 - power and batteries 195
 - printer 206, 207
 - program not responding 185
 - program not working properly 201
 - screen does not look right/
flickers 198
 - system resources 192
 - trouble prevention 208
 - URL address not found 190
 - using Startup options 189
 - warning resume failure 188
 - Windows won't start 187
 - Windows XP not working 188
 - program, starting 89
 - programs
 - not running correctly 201
 - projector 76
 - connecting 76
 - protection of stored data 2
- R**
- recharging
 - main battery 117
 - recording
 - .wav files 152
 - sounds 152
 - recording quality 153
 - recording sounds 152
 - Recovery media 39
 - recycle bin icon 140
 - RJ-11 jack 159
 - Run dialog box 91
- S**
- safety
 - disposing of batteries 127
 - icons 38
 - saving files 93
 - screen
 - blank 197
 - does not look normal/flickers 198
 - seating 43
 - secondary button 73
 - security 166
 - selecting a place to work 41
 - setting up
 - adding memory 55
 - computer 57
 - TOSHIBA Touch and Launch 182
 - setting up a connection 144
 - setting up your computer 47
 - settings
 - TOSHIBA Touch and Launch 182
 - shutting down more quickly 107
 - sound
 - problem solving 203
 - sound recording 153
 - sounds
 - recording 152
 - speakers
 - external, connecting 82
 - using external 153
 - Stand By mode hot key 215
 - Standby 111
 - Standby mode
 - going into more quickly 112
 - starting again from 113
 - start button 140
 - starting a program 89
 - Run dialog box 91
 - Windows Explorer 90
 - Windows Start menu 90
 - starting up the computer

- from Shut down 108
 - from Standby 113
- Startup menu
 - problem solving 189
- stored data protection 2
- supervisor password, deleting 177
- supervisor password, set up 176
- System Setup 187
- system tray 141

T

- taskbar 141
- telephone line
 - connecting to modem 158
- television
 - adjusting display 78
- Toshiba
 - Internet Web sites 211
- Toshiba Console 165
- Toshiba Hardware Setup 171
- Toshiba online resources 113
- TOSHIBA Touch and Launch 179
 - disable/enable 183
- Toshiba utilities 160
- turning off the computer 75
- turning on the computer 55
- turning on the power 54

U

- Universal Resource Locator (URL) 141
- USB mouse
 - connecting 132
- user password, disabling 176
- user passwords
 - setting 174
- using a file extension 95
- utilities
 - Toshiba Power Saver Utility 166

V

- video projector
 - adjusting display 78
- volume mute hot key 213

W

- warranty
 - limited warranty 40
- Web sites 210
 - Support Online 191
- Web sites, Toshiba 211
- Wi-Fi
 - wireless networking 143
- Wi-Fi Mini PCI modules 136
- Windows Explorer 90
- Windows Media Player 149
- Windows Millennium Edition
 - Help 191
- Windows Start menu 90
- Windows XP
 - Help 190
 - Help and Support 190
 - problem solving 188
- Windows XP Professional desktop 138
- Windows XP Professional taskbar 141
- wireless interoperability 7
- wireless networking 143
- Wizards
 - Dial-Up Networking Wizard 143
- work habits 45