



# **CPCI-6020 CompactPCI Single Board Computer**

**Installation and Use**

**6806800A51C**

February 2008

© Copyright 2008, 2007 Motorola

All rights reserved.

## Trademarks

Motorola® and the stylized M logo are trademarks registered in the U.S. Patent and Trademark Office.

PowerPC® is a registered trademark of International Business Machines and is used by Motorola Inc. under license from IBM Corporation.

CompactPCI® is a registered trademark of PCI Industrial Computer Manufacturers Group. All other product or service names mentioned in this document are trademarks or registered trademarks of their respective holders.

All other product or service names mentioned in this document are the property of their respective holders.

## Notice

While reasonable efforts have been made to assure the accuracy of this document, Motorola assumes no liability resulting from any omissions in this document, or from the use of the information obtained therein. Motorola reserves the right to revise this document and to make changes from time to time in the content hereof without obligation of Motorola to notify any person of such revision or changes.

Electronic versions of this material may be read online, downloaded for personal use, or referenced in another document as a URL to a Motorola website. The text itself may not be published commercially in print or electronic form, edited, translated, or otherwise altered without the permission of Motorola,

It is possible that this publication may contain reference to or information about Motorola products (machines and programs), programming, or services that are not available in your country. Such references or information must not be construed to mean that Motorola intends to announce such Motorola products, programming, or services in your country.

## Limited and Restricted Rights Legend

If the documentation contained herein is supplied, directly or indirectly, to the U.S. Government, the following notice shall apply unless otherwise agreed to in writing by Motorola.

Use, duplication, or disclosure by the Government is subject to restrictions as set forth in subparagraph (b)(3) of the Rights in Technical Data clause at DFARS 252.227-7013 (Nov. 1995) and of the Rights in Noncommercial Computer Software and Documentation clause at DFARS 252.227-7014 (Jun. 1995).

## Contact Address

Motorola Inc.

ECC Embedded Communications Computing

2900 South Diablo Way, Suite 190

Tempe, Arizona 85282

# Contents

---

<b>About this Manual</b> .....	<b>13</b>
<b>Safety Notes</b> .....	<b>19</b>
<b>Sicherheitshinweise</b> .....	<b>25</b>
<b>1 Introduction</b> .....	<b>31</b>
1.1 Features .....	31
1.2 Standard Compliances .....	32
1.3 Ordering Information .....	33
1.3.1 Supported Board Models .....	33
1.3.2 Board Accessories .....	34
<b>2 Hardware Preparation and Installation</b> .....	<b>35</b>
2.1 Overview .....	35
2.2 Unpacking and Inspecting the Board .....	35
2.3 Overview of Start-up Procedure .....	36
2.4 Equipment Required .....	37
2.5 Environmental and Power Requirements .....	37
2.5.1 Environmental Requirements .....	37
2.5.2 Power Requirements .....	39
2.5.3 Thermal Requirements .....	39
2.6 Hardware Configuration .....	39
2.7 CPCI-6020 Baseboard Preparation .....	40
2.8 Jumper Settings .....	41
2.8.1 Flash Bank Selection .....	41
2.8.2 Harrier Power Up Configuration Header .....	42
2.8.3 PMC 66 MHz Disable .....	42
2.8.4 Enable/Disable +12 V and -12 V Use .....	42
2.8.5 Enable/Disable Lockdown of One or More Flash Blocks for Bank A .....	43
2.8.6 Enable Write-Protect for Entire Flash on Bank A .....	43
2.8.7 Remote Switch .....	43
2.9 Hardware Installation .....	43
2.10 PMC Module Installation .....	44
2.11 CompactFlash Memory Card Installation .....	46
2.12 Before You Install or Remove a Board .....	47
2.12.1 Watch for Bent Pins or Other Damage .....	48
2.12.2 Use Caution When Installing or Removing Boards .....	48

2.12.3	Understanding Hot Swap	48
2.12.4	Recognize Different Injector/Ejector Lever Types	49
2.12.5	Verify Slot Usage	50
2.12.6	Preserve EMI Compliance	50
2.13	Installing and Removing a Module	51
2.14	Startup and Operation	54
2.15	System Considerations	55
<b>3</b>	<b>Controls, LEDs, and Connectors</b>	<b>57</b>
3.1	Overview	57
3.2	CPCI-6020 Baseboard Layout	57
3.3	Front Panel Connectors and LEDs	58
3.3.1	Front Panel Ethernet Port	58
3.3.2	Front Panel Asynchronous Serial Port	59
3.3.3	Front Panel USB ports	59
3.3.4	ABORT# Switch	60
3.3.5	RESET# Switch	60
3.3.6	Front Panel LEDs	60
3.4	Connector Pin Assignments	60
3.4.1	CompactPCI Bus Connectors	60
3.4.2	CompactPCI User I/O Connector	63
3.4.3	CompactPCI User I/O Connector	64
3.4.4	CompactPCI User I/O Connector	65
3.4.5	Memory Mezzanine Connectors	67
3.4.6	PCI Mezzanine Card (PMC) Connectors	68
3.4.7	Lock Down Flash Enable Jumper	72
3.4.8	PMC 66 Mhz Disable Jumper	73
3.4.9	Remote Switch Connector	73
3.4.10	Flash Write Protect Enable Jumper	73
3.4.11	Harrier Power Up Configuration	74
3.4.12	Xport Flash Bank Select Header	74
3.4.13	RISCWatch Header	74
3.4.14	Mictor Debug Connector	75
<b>4</b>	<b>Functional Description</b>	<b>81</b>
4.1	Overview	81
4.2	Block Diagram	82
4.3	Local PCI Bus Resources	83
4.3.1	PCI Bus A Resources	83
4.3.1.1	Local CompactPCI Bus	83
4.3.1.2	Remote (Expansion) CompactPCI Bus	83
4.3.1.3	Primary Ethernet Channel	83
4.3.1.4	ISA Bridge, Including EIDE Function	84
4.3.1.5	EIDE Interface	84
4.3.1.6	ISA Bus Resources	84

4.3.1.7	Synchronous Serial Ports	84
4.3.1.8	USB Controller	85
4.4	PCI Bus B Resources	85
4.4.1	PMC Slot	85
4.4.2	Secondary Ethernet Channel	86
4.5	Processor Bus Resources	87
4.5.1	Processor	87
4.5.2	L2 Cache	87
4.6	Harrier System Memory Controller and PCI Host Bridge ASIC	87
4.6.1	Dual Harrier Assignments	88
4.6.2	Harrier Power-Up Configuration	88
4.6.3	Debug Connector	90
4.6.4	PPC Bus Arbitration	90
4.7	ECC Memory Bus Resources	90
4.7.1	Harrier A Memory Bus	90
4.7.2	Harrier B Memory Bus	91
4.7.3	RAM500 Memory Mezzanine	91
4.8	Harrier Xport Resources	91
4.8.1	Harrier A, Channel 0 - Onboard Bank A Flash	92
4.8.2	Harrier A, Channel 1 - Socketed Bank B Flash	92
4.8.3	Harrier A, Channel 2 - NVRAM, RTC, External Register Set	92
4.8.4	Harrier A, Channel 3	92
4.8.5	Harrier B, Channel 0, 1, 2 and 3	92
4.9	Other Harrier Resources	93
4.9.1	I2C Bus Resources - Serial EEPROM	93
4.9.2	Asynchronous Serial Ports	93
4.9.3	32-Bit Timers	93
4.9.4	Watchdog Timers	93
4.10	Other Board Resources	94
4.10.1	Miscellaneous Control and Status	94
4.10.2	Clock Generator	94
4.10.3	Onboard Power Supplies	95
4.10.4	Board Reset Logic	95
4.10.5	Soft Reset	97
4.10.6	Front Panel Resources	97
4.10.7	ABORT# and RESET# Switches	97
4.10.8	On-Board LEDs	98
4.10.9	Harrier Power Up Configuration Header	98
4.11	Hot Swap Support	98
4.12	High Availability Support	98
4.12.1	HSC Bridge Board Interface	98
4.12.2	Local CompactPCI Bus Interface	99
4.12.3	Secondary Bus Arbitration	99
4.12.4	Secondary Bus Tri-Stating	99
4.12.5	System Slot Hot Swap	99
4.13	EIDE Interface	100

4.14	Ethernet Interface	100
4.15	Hot Swap Support	100
4.16	PMC Interface Module (PIM)	100
4.17	Asynchronous Serial Ports	101
4.18	Synchronous Serial Ports	101
4.19	I/O Signal Multiplexing (IOMUX)	101
4.20	Serial Interface Modules (SIM)	103
4.21	PMC Interface Module (PIM)	103
4.22	PMC Interface Module Form Factor	104
4.23	PMC Interface Connector	105
4.24	Host I/O Connector	105
4.25	Speaker Port	105
4.26	Floppy Disk Port	105
4.27	Mouse and Keyboard Port	105
<b>5</b>	<b>Firmware</b>	<b>107</b>
5.1	PPCBug Overview	107
5.2	PPCBug Basics	107
5.3	Memory Requirements	108
5.4	PPCBug Implementation	108
5.5	MPU, Hardware and Firmware Initialization	108
5.6	Using PPCBug	110
5.7	Debugger Commands	110
5.8	Diagnostic Tests	114
<b>6</b>	<b>RAM500 Memory Expansion Module</b>	<b>117</b>
6.1	Overview	117
6.2	RAM500 Description	117
6.3	RAM500 Module Installation	118
6.4	Features	119
6.4.1	SROM	119
6.4.2	Host Clock Logic	120
6.4.3	Serial Presence Detect (SPD) Data	120
6.5	RAM500 Connectors	120
6.5.1	Bottom Side Memory Expansion Connector (P1)	120
6.5.2	Top Side Memory Expansion Connector (J1)	123
6.6	RAM500 Programming Issues	125
<b>7</b>	<b>Transition Module Preparation and Installation</b>	<b>127</b>
7.1	Overview	127
7.2	General Description	127
7.2.1	Component Layout	129
7.2.2	Rear Panel Connectors	130
7.3	Unpacking and Inspecting the RTM	131

---

7.4	Preparing the Transition Module .....	131
7.4.1	Serial Ports 1 and 2 .....	131
7.4.2	Serial Ports 3 and 4 .....	132
7.4.3	Serial Interface Module Circuitry .....	133
7.4.4	Port Configuration .....	135
7.5	Installing the SIMs .....	136
7.6	Installing the PIM .....	138
7.7	Installing and Removing the Transition Module .....	140
7.8	Connectors and Cables .....	141
7.9	Connector Pin Assignments .....	143
7.9.1	CompactPCI Connectors .....	143
7.9.2	PMC I/O Module Connector .....	143
7.9.3	10BaseT/100BaseTx Connectors .....	146
7.9.4	COM1 Connector .....	146
7.9.5	COM2 Header .....	147
7.9.6	EIDE Header .....	147
7.9.7	Floppy Port Header .....	148
7.9.8	+5VDC Power Connector .....	148
7.9.9	Keyboard/Mouse Connector .....	149
7.9.10	Sync/Async Serial Ports .....	149
7.9.11	Speaker Output Header .....	150
<b>8</b>	<b>CNFG and ENV Commands .....</b>	<b>151</b>
8.1	Overview .....	151
8.2	CNFG - Configure Board Information .....	151
8.3	ENV - Set Environment .....	152
8.4	Configuring the PPCBug Parameters .....	152
<b>A</b>	<b>Related Documentation .....</b>	<b>161</b>
A.1	Embedded Communications Computing Documents .....	161
A.2	Manufacturers' Documents .....	161
A.3	Related Specifications .....	162
<b>Index</b>	<b>.....</b>	<b>165</b>





# List of Tables

---

Table 1-1	Features	31
Table 1-2	Board Standard Compliances	32
Table 2-1	Startup Overview	36
Table 2-2	Specifications	38
Table 2-3	Baseboard and RTM Power Requirements	39
Table 2-4	Slot Usage Indicators	50
Table 3-1	Ethernet Connector Pin Assignments	58
Table 3-2	COM1 Pin Assignments	59
Table 3-3	USB Port 1	59
Table 3-4	USB Port 0	59
Table 3-5	Front Panel LEDs	60
Table 3-6	J1 CompactPCI Connector	61
Table 3-7	J2 CompactPCI Connector	61
Table 3-8	J3 CompactPCI User I/O Connector	63
Table 3-9	Signal Descriptions for the J3 Connector	63
Table 3-10	J4 Local PCI Expansion Connector Pinout	64
Table 3-11	J5 User I/O Connector	65
Table 3-12	J5 Signal Descriptions	65
Table 3-13	J8 and J27 Memory Mezzanine Connector	67
Table 3-14	PMC Connector J11 Pin Assignments	68
Table 3-15	J12 PMC Connector J12 Pin Assignments	69
Table 3-16	PMC Connector J13 Pin Assignments	70
Table 3-17	PMC Connector J14 Pin Assignments	71
Table 3-18	J17 Lock Down Flash Enable Jumper	72
Table 3-19	J21 PMC 66 MHz Disable Jumper	73
Table 3-20	J19 Remote Switch Connector	73
Table 3-21	J20 Flash Write Protect Enable Jumper	73
Table 3-22	J22 Harrier Power Up Configuration Header Pin Assignments	74
Table 3-23	J24 Xport Flash Bank Select Header	74
Table 3-24	J25 RISCWatch Header Pin Assignments	74
Table 3-25	J28 Debug Connector	75
Table 4-1	Special Function Processor PMC Pins	86
Table 4-2	Harrier Power-Up Configuration Settings	88
Table 4-3	Expansion SDRAM Memory Mezzanine Size Options	91
Table 4-4	Bank A Flash Options	92
Table 4-5	PPC to PCI Clock Ratios	94
Table 4-6	Reset Sources and Devices Affected	96
Table 4-7	Multiplexing Sequence of the IOMX Function	102
Table 5-1	Debugger Commands	111
Table 5-2	Diagnostic Test Groups	115

## List of Tables

---

Table 6-1	RAM500 SDRAM Memory Size Options .....	118
Table 6-2	RAM500 Feature Summary .....	119
Table 6-3	RAM500 Bottom Side Connector (P1) Pin Assignments .....	120
Table 6-4	RAM500 Top Side Connector (J1) Pin Assignments .....	123
Table 7-1	SIM Model Numbers .....	132
Table 7-2	Rear Transition Module Connectors/Headers .....	141
Table 7-3	Rear Transition Module Cables .....	142
Table 7-4	PMC I/O Module - Host I/O Connector Pin Assignments .....	143
Table 7-5	PMC I/O Module - PMC I/O Connector Pin Assignments .....	144
Table 7-6	10BaseT/100BaseTx Connector Pin Assignments .....	146
Table 7-7	COM1 Connector Pin Assignments .....	146
Table 7-8	COM2 Header Pin Assignments .....	147
Table 7-9	EIDE Header Pin Assignments .....	147
Table 7-10	Floppy Header Pin Assignments .....	148
Table 7-11	+5Vdc Power Connector .....	148
Table 7-12	Keyboard/Mouse Connector Pin Assignments .....	149
Table 7-13	Sync/Async Serial Connector Pin Assignments .....	149
Table 7-14	Speaker Output Connector Pin Assignments .....	150
Table A-1	Embedded Communications Computing Documents .....	161
Table A-2	Manufacturers' Documents .....	161
Table A-3	Related Specifications .....	162

# List of Figures

---

Figure 2-1	Header Locations and Jumper Settings .....	41
Figure 2-2	Injector/Ejector Lever Types .....	49
Figure 2-3	Start Up Flow Diagram .....	55
Figure 3-1	Headers, Connectors and LEDs .....	57
Figure 3-2	Front Panel Connectors and LEDs .....	58
Figure 4-1	Block Diagram .....	82
Figure 4-2	Reset Block Diagram .....	96
Figure 4-3	Serial Port Signal Multiplexing .....	101
Figure 4-4	P2MX Signal Timings .....	103
Figure 4-5	PMC Interface Module Layout .....	104
Figure 7-1	Block Diagram .....	128
Figure 7-2	Component Layout .....	129
Figure 7-3	Rear Panel Connectors, Cut-outs .....	130
Figure 7-4	Ports 3 and 4 Header Settings .....	133
Figure 7-5	EIA-232-D DCE Ports 3 and 4 Configuration .....	135
Figure 7-6	EIA-232-D DTE Ports 3 and 4 Configuration .....	136



# About this Manual

---

## Overview of Contents

This manual provides the information required to install and configure an CPCI-6020 Single Board Computer. Moreover, this manual provides specific preparation and installation information and data applicable to the board. The CPCI-6020 was previously offered as the MCP820 Single Board Computer.

The CPCI-6020 is a high-performance CompactPCI single board computer featuring the MPC7410 with Alti-Vec™ technology for algorithmic intensive computational capabilities.

This manual is divided into the following chapters and appendices:

[Safety Notes](#), a collection of standard product safety notes for the CPCI-6020 in English.

[Sicherheitshinweise](#), a collection of standard product safety notes for the CPCI-6020 translated to German.

[Chapter 1, Introduction](#), lists the features of the CPCI-6020 baseboard, standards compliances, model numbers for boards, memory, and RTMs.

[Chapter 2, Hardware Preparation and Installation](#), includes a description of the CPCI-6020, unpacking instructions, environmental and power requirement, and how to prepare and install the CompactFlash, a PMC module, and the CPCI-6020 baseboard.

[Chapter 3, Controls, LEDs, and Connectors](#) provides illustrations of the board components and face plate details. This chapter also gives descriptions for the onboard and front panel LEDs and connections and pinout information for connectors, headers and jumpers.

[Chapter 4, Functional Description](#) describes the major features of the CPCI-6020 baseboard and the CPCI-6020-MCPTM-01 transition module. These descriptions include both programming and hardware characteristics of major components.

[Chapter 5, Firmware](#) describes the role, process and commands employed by the CPCI-6020 diagnostic and initialization firmware PPCBug. This chapter also briefly describes how to use the debugger commands.

[Chapter 6, RAM500 Memory Expansion Module](#) provides information for installing the RAM500 memory mezzanine. It also provides information on pinouts and features.

[Chapter 7, Transition Module Preparation and Installation](#), includes a description of the CPCI-6020-MCPTM-01 rear transition module. The chapter provides illustrations of the RTM components and face plate details. It describes jumper settings, port configuration diagrams, and procedures for installing SIMs and PIMs. Pin assignment tables for the RTM are included in this chapter.

[Chapter 8, CNFG and ENV Commands](#) describes how to use the CNFG and ENV commands of PPCBug to modify certain parameters within the CPCI-6020.

[Appendix A, Related Documentation](#) provides listings for Motorola publications, manufacturer's documents and related industry specification for this product.

## Abbreviations

This document uses the following abbreviations:







Abbreviation	Description
ACE	Asynchronous Communications Element
ANSI	American National Standards Institute
ASIC	Application Specific Integrated Circuit
BDRAM	Battery Backed-up RAM
BDFL	Board Fail
CF	Compact Flash
CHRP	Common Hardware Reference Platform
CMOS	Complementary metal oxide semiconductor
DCE	Data Circuit Termination
DTE	Data Terminal Equipment
EIDE	Enhanced Integrated Design Electronics
EMI	Electro Magnetic Interference
ESD	Electro Static Discharge
FDD	Floppy Disk Drive
GB	Gigabyte
HA	High Availability
HDD	Hard Disk Drive
HSC	Hot Swap Controller
IOMUX	I/O Signal Multiplexing
ISA	Industry Standard Architecture
KB	Kilobyte
MAC	Media Access Controller
MPU	Microprocessing Unit
Mbps	Megabits per second
MB	Megabyte
NVRAM	Non Volatile Random Access Memory
OHCI	Open Host Controller Interface
PF	Port Format
PHB	PCI Host Bridge
PHY	Physical Layer
PIB	PCI Arbiter

Abbreviation	Description
PIM	PMC Interface Module
PIO	Parallel Input Output
PIRQx	PCI Interrupts
PMC	Peripheral Mezzanine Card
PRP	PowerPC Reference Platform
PrPMC	Processor PMC
RISC	Reduced Instruction Set Computer
RoHS	Restriction of Hazardous Substances
SIM	Serial Interface Module
SMC	System Memory Controller
SPD	Serial Presence Detect
TA	Terminal Attach
UART	Universal Asynchronous Receiver-Transmitter
USB	Universal Serial Bus
VPD	Vital Product Data

## Conventions

The following table describes the conventions used throughout this manual.

Notation	Description
0x00000000	Typical notation for hexadecimal numbers (digits are 0 through F), for example used for addresses and offsets
0b0000	Same for binary numbers (digits are 0 and 1)
<b>bold</b>	Used to emphasize a word
Screen	Used for on-screen output and code related elements or commands in body text
<b>Courier + Bold</b>	Used to characterize user input and to separate it from system output
<i>Reference</i>	Used for references and for table and figure descriptions
File > Exit	Notation for selecting a submenu
<text>	Notation for variables and keys
[text]	Notation for software buttons to click on the screen and parameter description
...	Repeated item for example node 1, node 2, ..., node 12

Notation	Description
.	Omission of information from example/command that is not necessary at the time being
..	Ranges, for example: 0..4 means one of the integers 0,1,2,3, and 4 (used in registers)
	Logical OR
  <p>XX XX XX</p>	Indicates a hazardous situation which, if not avoided, could result in death or serious injury
  <p>XX XX XX</p>	Indicates a hazardous situation which, if not avoided, may result in minor or moderate injury
 <p>XX XX XX</p>	Indicates a property damage message
 <p>XX XX</p>	No danger encountered. Pay attention to important information

## Summary of Changes

This manual has been revised and replaces all prior editions.

Part Number	Publication Date	Description
6806800A36A		First release. Replaces MCP820 SBC.
6806800A36B	January 2007	J24 Xport flash bank select header description corrected.
6806800A36C	January 2008	Remove Winbond PC97317 for 6/6 version. Legacy functionality remains via serial, Ethernet, and CompactFlash components. RoHS 6/6 compliancy. Editorial and style changes to manual.



## Comments and Suggestions

We welcome and appreciate your comments on our documentation. We want to know what you think about our manuals and how we can make them better.

Mail comments to:

- Motorola, Inc.  
Embedded Communications Computing  
2900 South Diablo Way, Suite 190  
Tempe, Arizona 85282
- [reader-comments@ecc.mot.com](mailto:reader-comments@ecc.mot.com)

In all your correspondence, please list your name, position, and company. Be sure to include the title, part number, and revision of the manual and tell how you used it.



# Safety Notes

---

This section provides warnings that precede potentially dangerous procedures throughout this manual. Instructions contained in the warnings must be followed during all phases of operation, service, and repair of this equipment. You should also employ all other safety precautions necessary for the operation of the equipment in your operating environment. Failure to comply with these precautions or with specific warnings elsewhere in this manual could result in personal injury or damage to the equipment.

Motorola intends to provide all necessary information to install and handle the product in this manual. Because of the complexity of this product and its various uses, we do not guarantee that the given information is complete. If you need additional information, ask your Motorola representative.

The product has been designed to meet the standard industrial safety requirements. It must not be used except in its specific area of office telecommunication industry and industrial control.

Only personnel trained by Motorola or persons qualified in electronics or electrical engineering are authorized to install, remove or maintain the product.

The information given in this manual is meant to complete the knowledge of a specialist and must not be used as replacement for qualified personnel.

Keep away from live circuits inside the equipment. Operating personnel must not remove equipment covers. Only Factory Authorized Service Personnel or other qualified service personnel may remove equipment covers for internal subassembly or component replacement or any internal adjustment.

Do not install substitute parts or perform any unauthorized modification of the equipment or the warranty may be voided. Contact your local Motorola representative for service and repair to make sure that all safety features are maintained.

## EMC

This equipment has been tested and found to comply with the limits for a Class A digital device, pursuant to Part 15 of the FCC Rules. These limits are designed to provide reasonable protection against harmful interference when the equipment is operated in a commercial environment. This equipment generates, uses, and can radiate radio frequency energy and, if not installed and used in accordance with the instruction manual, may cause harmful interference to radio communications.

Operation of this equipment in a residential area is likely to cause harmful interference in which case the user will be required to correct the interference at his own expense. Changes or modifications not expressly approved by Motorola Embedded Communications Computing could void the user's authority to operate the equipment.

**Board products are tested in a representative system to show compliance with the above mentioned requirements. A proper installation in a compliant system will maintain the required performance. Use only shielded cables when connecting peripherals to assure that appropriate radio frequency emissions compliance is maintained.**

## Operation

### Damage of Module Surface

High humidity and condensation on the product surface causes short circuits. Do not operate the product outside the specified environmental limits. Make sure the product is completely dry and there is no moisture on any surface before applying power.

### Overheating and Damage of the Product

Operating the product without forced air cooling may lead to overheating and thus damage of the product. When operating the product, make sure that forced air cooling is available in the shelf.

### Signaling Requirements

Ensure the backplane does not bus J3, J4 or J5 signals to other slots. Set the VIO on the backplane to either +3.3 V or +5 V, depending upon your system's signaling requirements.

### Data Loss

Powering down or removing a board before the operating system or other software running on the board has been properly shut down may cause corruption of data or file systems. Make sure all software is completely shut down before removing power from the board or removing the board from the chassis.

### Data Loss

Although a command that allows erasing and reprogramming of flash memory is available, note that reprogramming any portion of the CPCI-6020 baseboard's flash memory (Bank B) will erase everything currently contained in the baseboard flash, including the PPCBug debugger. Use caution when reprogramming or erasing flash memory. Refer to the programming documents listed in [Appendix A, Related Documentation](#).

## Installation

### Personal Injury

Dangerous voltages capable of causing death exist. To prevent injury, use extreme caution when handling, testing and adjusting this equipment.

### Damage of Circuits

Electrostatic discharge and incorrect module installation and removal can damage circuits or shorten their life.

Before touching the module or electronic components, make sure that you are working in an ESD-safe environment.

#### **Damage of Module and Additional Devices**

Incorrect installation of additional devices or modules may damage the product or the additional devices or modules.

Before installing or removing an additional device or module, read the respective documentation.

#### **Board Damage**

Inserting or removing modules that are not HA capable with power applied may result in damage to module components.

Verify that your board is HA capable.

#### **Product Damage**

Prevent possible damage to module components by verifying the proper slot usage for your configuration.

Check the icons and colored card rails for slot purpose prior to installing a module.

#### **Damage to the Product/Backplane or System Components**

Bent pins or loose components can cause damage to the product, the backplane, or other system components.

Therefore, carefully inspect the product and the backplane for both pin and component integrity before installation.

Embedded Communications Computing and our suppliers take significant steps to ensure there are no bent pins on the backplane or connector damage to the boards prior to leaving the factory. Bent pins caused by improper installation or by inserting boards with damaged connectors could void the ECC warranty for the backplane or boards.

**Preserve EMI Compliance**

To preserve compliance with applicable standards and regulations for electromagnetic interference (EMI), during operation all front and rear openings on the chassis or board face plates must be filled with an appropriate card or covered with a filler panel. If the EMI barrier is open, devices may cause or be susceptible to excessive interference.

## Rear Transition Module

**Product Damage**

Inserting or removing modules in a non-hot swap chassis with the power applied may result in damage to the module components. The CPCI-6020-MCPTM-01 is not a hot swap board, but it may be installed in a hot swap chassis with power applied if the corresponding CPCI-6020 is removed from the front slot first.

## Environment

Always dispose of used AMC modules, system components and RTMs according to your country's legislation and manufacturer's instructions.





# Sicherheitshinweise

---

Dieses Kapitel enthält Hinweise, die potentiell gefährlichen Prozeduren innerhalb dieses Handbuchs vorrangestellt sind. Beachten Sie unbedingt in allen Phasen des Betriebs, der Wartung und der Reparatur des Systems die Anweisungen, die diesen Hinweisen enthalten sind. Sie sollten außerdem alle anderen Vorsichtsmaßnahmen treffen, die für den Betrieb des Produktes innerhalb Ihrer Betriebsumgebung notwendig sind. Wenn Sie diese Vorsichtsmaßnahmen oder Sicherheitshinweise, die an anderer Stelle dieses Handbuchs enthalten sind, nicht beachten, kann das Verletzungen oder Schäden am Produkt zur Folge haben.

Motorola ist darauf bedacht, alle notwendigen Informationen zum Einbau und zum Umgang mit dem Produkt in diesem Handbuch bereit zu stellen. Da es sich jedoch um ein komplexes Produkt mit vielfältigen Einsatzmöglichkeiten handelt, können wir die Vollständigkeit der im Handbuch enthaltenen Informationen nicht garantieren. Falls Sie weitere Informationen benötigen sollten, wenden Sie sich bitte an die für Sie zuständige Geschäftsstelle von Motorola.

Das System erfüllt die für die Industrie geforderten Sicherheitsvorschriften und darf ausschließlich für Anwendungen in der Telekommunikationsindustrie und im Zusammenhang mit Industriesteuerungen verwendet werden.

Einbau, Wartung und Betrieb dürfen nur von durch Motorola ausgebildetem oder im Bereich Elektronik oder Elektrotechnik qualifiziertem Personal durchgeführt werden. Die in diesem Handbuch enthaltenen Informationen dienen ausschließlich dazu, das Wissen von Fachpersonal zu ergänzen, können dieses jedoch nicht ersetzen.

Halten Sie sich von stromführenden Leitungen innerhalb des Produktes fern. Entfernen Sie auf keinen Fall Abdeckungen am Produkt. Nur werksseitig zugelassenes Wartungspersonal oder anderweitig qualifiziertes Wartungspersonal darf Abdeckungen entfernen, um Komponenten zu ersetzen oder andere Anpassungen vorzunehmen.

Installieren Sie keine Ersatzteile oder führen Sie keine unerlaubten Veränderungen am Produkt durch, sonst verfällt die Garantie. Wenden Sie sich für Wartung oder Reparatur bitte an die für Sie zuständige Geschäftsstelle von Motorola. So stellen Sie sicher, dass alle sicherheitsrelevanten Aspekte beachtet werden.

## EMV

Das Produkt wurde in einem Motorola Standardsystem getestet. Es erfüllt die für digitale Geräte der Klasse A gültigen Grenzwerte in einem solchen System gemäß den FCC-Richtlinien Abschnitt 15 bzw. EN 55022 Klasse A. Diese Grenzwerte sollen einen angemessenen Schutz vor Störstrahlung beim Betrieb des Produktes in Gewerbe- sowie Industriegebieten gewährleisten.

**Das Produkt arbeitet im Hochfrequenzbereich und erzeugt Störstrahlung. Bei unsachgemäßem Einbau und anderem als in diesem Handbuch beschriebenen Betrieb können Störungen im Hochfrequenzbereich auftreten.**

**Wird das Produkt in einem Wohngebiet betrieben, so kann dies mit grosser Wahrscheinlichkeit zu starken Störungen führen, welche dann auf Kosten des Produktanwenders beseitigt werden müssen. Änderungen oder Modifikationen am Produkt, welche ohne ausdrückliche Genehmigung von Motorola ECC durchgeführt werden, können dazu führen, dass der Anwender die Genehmigung zum Betrieb des Produktes verliert. Boardprodukte werden in einem repräsentativen System getestet, um zu zeigen, dass das Board den oben aufgeführten EMV-Richtlinien entspricht. Eine ordnungsgemässe Installation in einem System, welches die EMV-Richtlinien erfüllt, stellt sicher, dass das Produkt gemäss den EMV-Richtlinien betrieben wird. Verwenden Sie nur abgeschirmte Kabel zum Anschluss von Zusatzmodulen. So ist sichergestellt, dass sich die Aussendung von Hochfrequenzstrahlung im Rahmen der erlaubten Grenzwerte bewegt.**

**Warnung! Dies ist eine Einrichtung der Klasse A. Diese Einrichtung kann im Wohnbereich Funkstörungen verursachen. In diesem Fall kann vom Betreiber verlangt werden, angemessene Maßnahmen durchzuführen.**

---

## Betrieb

### **Beschädigung des Produktes**

Hohe Luftfeuchtigkeit und Kondensat auf der Oberfläche des Produktes können zu Kurzschlüssen führen.

Betreiben Sie das Produkt nur innerhalb der angegebenen Grenzwerte für die relative Luftfeuchtigkeit und Temperatur. Stellen Sie vor dem Einschalten des Stroms sicher, dass sich auf dem Produkt kein Kondensat befindet.

### **Überhitzung und Beschädigung des Produktes**

Betreiben Sie das Produkt ohne Zwangsbelüftung, kann das Produkt überhitzt und schließlich beschädigt werden.

Bevor Sie das Produkt betreiben, müssen Sie sicher stellen, dass das Shelf über eine Zwangskühlung verfügt.

### **Anforderungen hinsichtlich Signalverbindungen**

Stellen Sie sicher, dass J3, J4 und J5 Signale nicht über die Backplane mit anderen Slots verbunden sind.

Setzen Sie die VIO der Backplane auf entweder +3.3 V oder +5 V, gemäss den jeweiligen Systemanforderungen.

### **Datenverlust**

Das Herunterfahren oder die Deinstallation eines Boards bevor das Betriebssystem oder andere auf dem Board laufende Software ordnungsmässig beendet wurde, kann zu partiellem Datenverlust sowie zu Schäden am Filesystem führen.

Stellen Sie sicher, dass sämtliche Software auf dem Board ordnungsgemäss beendet wurde, bevor Sie das Board herunterfahren oder das Board aus dem Chassis entfernen.

### **Datenverlust**

Obwohl das Board über ein Softwarekommando verfügt, welches das Löschen und die Neuprogrammierung eines Flashes erlaubt, beachten Sie, dass die Neuprogrammierung auch nur irgendeines Abschnittes des Flashes (Bank B) auf dem CPCI-6020 zur Löschung sämtlicher Inhalte des Flashes führt, einschliesslich des PPC-Debuggers.

Gehen Sie sehr sorgfältig vor, wenn Sie einen Flash löschen oder neu programmieren.

Weitere Informationen finden Sie in den Softwarebeschreibungen im Abschnitt

[Appendix A, Related Documentation](#).

## Installation

### **Schwere Verletzungen oder Tod**

Dieses System wird mit gefährlichen Spannungen betrieben, die schwere Verletzungen oder Tod verursachen können.

Gehen Sie deshalb extrem vorsichtig vor, wenn Sie mit dem System oder seinen Komponenten umgehen, es testen oder anpassen.

### **Beschädigung des Produktes und von Zusatzmodulen**

Fehlerhafte Installation von Zusatzmodulen, kann zur Beschädigung des Produktes und der Zusatzmodule führen.

Lesen Sie daher vor der Installation von Zusatzmodulen die zugehörige Dokumentation.

### **Beschädigung von Schaltkreisen**

Elektrostatice Entladung und unsachgemäßer Ein- und Ausbau des Produktes kann Schaltkreise beschädigen oder ihre Lebensdauer verkürzen.

Bevor Sie das Produkt oder elektronische Komponenten berühren, vergewissern Sie sich, daß Sie in einem ESD-geschützten Bereich arbeiten.

### **Beschädigung des Boards**

Die Installation oder Deinstallation eines nicht HA-fähigen Modules in ein System/aus einem System, dessen Spannungsversorgung eingeschaltet ist, kann zur Beschädigung des Modules führen.

Stellen Sie sicher, dass das Modul HA-fähig ist.

### **Beschädigung des Produktes**

Vermeiden Sie eine mögliche Beschädigung des Modules, indem Sie sicherstellen, dass der zu verwendende Slot für Ihr Modul und Ihre Systemkonfiguration geeignet ist.

Überprüfen Sie, bevor Sie das Modul installieren, die grafischen Symbole und die mit Farbcodes versehenen Führungsschienen. Diese geben Auskunft über den Verwendungszweck des Slots.

### **Beschädigung des Produktes, der Backplane oder von System Komponenten**

Verbogene Pins oder lose Komponenten können zu einer Beschädigung des Produktes, der Backplane oder von Systemkomponenten führen.

Überprüfen Sie daher das Produkt sowie die Backplane vor der Installation sorgfältig und stellen Sie sicher, dass sich beide in einwandfreien Zustand befinden und keine Pins verbogen sind.

Motorola Embedded Communications Computing (ECC) und unsere Zulieferer unternehmen größte Anstrengungen um sicherzustellen, dass sich Pins und Stecker von Boards vor dem Verlassen der Produktionsstätte in einwandfreiem Zustand befinden. Verbogene Pins, verursacht durch fehlerhafte Installation oder durch Installation von Boards mit beschädigten Steckern kann die durch ECC gewährte Garantie für Boards und Backplanes erlöschen lassen.

#### **Sicherstellung der EMV-Konformität**

Stellen Sie sicher, dass während des Betriebes alle Slots an der Vorder- und Rückseite des Chassis entweder mit einem geeignetem Board/Module oder mit einer Blindblende bestückt sind. So ist sichergestellt, dass alle Standards und Richtlinien hinsichtlich EMV erfüllt sind. Sobald die EMV-Abschirmung des Chassis durchlässig wird, können Boards/Module sowohl starke Störstrahlung aussenden als auch selber starker Störstrahlung ausgesetzt sein.

## **Rear Transition Module**

#### **Beschädigung des Produktes**

Die Installation oder Deinstallation eines Modules in ein nicht Hot-Swap-fähiges System/aus einem nicht Hot-Swap-fähigem System, dessen Spannungsversorgung eingeschaltet ist, kann zur Beschädigung des Modules führen. Das CPCI-6020-MCPTM-01 ist kein Hot-Swap-fähiges Board, aber es kann in ein Hot-Swap-fähiges Chassis installiert werden bei eingeschalteter Spannungsversorgung, unter der Voraussetzung, dass das zugehörige CPCI-6020-Board zuvor aus dem Slot an der Vorderseite entfernt wurde.

## **Umweltschutz**

Entsorgen Sie alte Batterien und/oder Blades/Systemkomponenten/RTMs stets gemäß der in Ihrem Land gültigen Gesetzgebung, wenn möglich immer umweltfreundlich.



## 1.1 Features

The following table summarizes the features of the CPCI-6020 single-board computers.

Table 1-1 Features

Feature	Description
Processor	Single MPC7410 Processor Core Frequency up to 500 MHz for MPC7410 Bus Clock Frequency of 100 MHz Address and data bus parity
L2 Cache	2 MB back side L2 Cache using pipeline burst-mode SRAMS Data bus parity
Flash	Xport Channel 0 (Bank A): 32 MB on-board using one 256 megabit device. Xport Channel 1 (Bank B): 1 MB socketed flash using two 512 kilobit devices. Bank A/B Reset vector select jumpers.
SDRAM	Double-Bit-Error detect, Single-Bit-Error correct across 72 bits Two connectors, one behind each Harrier, for use with RAM500 stacking SDRAM mezzanines. Using 512 megabit SDRAM devices on the mezzanine will allow a maximum of 2 GB memory.
Memory Controllers	Harriers' SMC (System Memory Controller).
PCI Host Bridges	Harriers' PHB (PCI Host Bridge).
Interrupt Controller	Harriers' MPIC (Multi-Processor Interrupt Controller).
PCI Interfaces	Dual 33 MHz, 32/64-bit PCI 2.1 busses bridging from the processor bus, one PCI Bus also capable of 66 MHz +3.3 V/+5 V universal signaling interface One PMC slot Connection through the J4 connector to the backplane Address/data parity per PCI specification
Ethernet Interface	Two 10BaseT/100BaseTx interfaces based on Intel 82551IT device. One port is routed to the backplane, the other port is routed to front panel (standard product). The latter port can also be routed to backplane, but it is determined by a custom-build option. Contact the custom solution center for more information. AT93C46 SROMs for 82551IT configuration
SROM	Two 8 KB dual-address I <sup>2</sup> C serial EEPROM devices for Vital Product Data and user configuration data 256-byte standard I2C serial EEPROMs (on mezzanines) for memory SPD
CompactPCI Interface	Intel 21154 PCI-to-PCI Bridge interfaces to Compact PCI Bus Capable of driving seven slots 64-bit primary bus/64-bit secondary bus interface Up to 33 MHz operation
Form Factor	6U Eurocard

Table 1-1 Features (continued)

Feature	Description
RTC/NVRAM	32 KB NVRAM/RTC/WDT provided by M48T37V Connected to Harrier A Xport 2 configured as 8-bit port
Watchdog Timers	Two independent programmable timers in each Harrier One programmable timer in M48T37V
Peripheral Support	USB host/hub interface 10BaseT/100BaseTX Ethernet interface IDE Interface for IDE flash and external IDE drive support Two 16550-compatible async serial ports (Harrier UART0/UART1) Two sync/async serial ports <b>CPCI-6020 (5E Only)</b> One PS/2 Keyboard and one PS/2 Mouse Floppy disk controller
PMC Slot	One 32/64-bit PMC slot with front-panel I/O plus rear I/O, 33/66 MHz capable
Local PCI Bus Expansion	Local 64-bit PCI bus routed to J4 to support additional PCI-to-PCI bridge and CompactPCI bus on companion card
Front Panel	Asynchronous COM port via RJ-45 10/100 MB Ethernet via RJ-45 Two USB ports Recessed RESET and ABORT switches CPU Activity and Board Fail LEDs Switch in handle to support hot swap
Debug Support	16550-compatible async serial port (in Harrier) with RS-232 interface Processor JTAG Interface RESET and ABORT signals Access to processor bus via Mictor connector

## 1.2 Standard Compliances

The CPCI-6020 is designed to be CE compliant and to meet the following standard requirements.

Table 1-2 Board Standard Compliances

Standard	Description
UL 60950-1 EN 60950-1 IEC 60950-1 CAN/CSA C22.2 No 60950-1	Safety Requirements (legal)



Table 1-2 Board Standard Compliances (continued)

Standard	Description
CISPR 22 CISPR 24 EN 55022 EN 55024 FCC Part 15 Industry Canada ICES-003 VCCI Japan AS/NZS CISPR 22 EN 300 386 NEBS Standard GR-1089 CORE	EMC requirements (legal) on system level (predefined Motorola system)
NEBS Standard GR-63-CORE ETSI EN 300 019 series	Environmental Requirements
Directive 2002/95/EC	Directive on the restriction of the use of certain hazardous substances in electrical and electronic equipment (RoHS)

## 1.3 Ordering Information

When ordering board variants or board accessories, use the order numbers given in the following tables.

### 1.3.1 Supported Board Models

At the time of publication of this manual, the CPCI-6020 Single Board Computer is available in the configurations shown below. Memory is purchased separately according to the following table.

Model Number	Description
CPCI-60206E-500	MPC7410, 500 MHz, memory separate (configured), no Super I/O
CPCI-60206E-505	MPC7410, 500 MHz, memory separate (configured), no USB, no Super I/O
CPCI-6020-500	MPC7410, 500 MHz, memory separate (configured), 5E
CPCI-6020-505	MPC7410, 500 MHz, memory separate (configured), no USB, 5E

### 1.3.2 Board Accessories

This table lists the available memory modules and Rear Transition Module available for the CPCI-6020.

Model Number	Description
RAM5006E-005	Top memory: 128 MB
RAM5006E-015	Bottom memory: 128 MB
RAM5006E-006	Top memory: 256 MB
RAM5006E-016	Bottom memory: 256 MB
RAM5006E-010	Top memory: 512 MB
RAM5006E-020	Bottom memory: 512 MB
RAM500-005	Top memory: 128 MB, 5E
RAM500-015	Bottom memory: 128 MB, 5E
RAM500-006	Top memory: 256 MB, 5E
RAM500-016	Bottom memory: 256 MB, 5E
RAM500-010	Top memory: 512 MB, 5E
RAM500-020	Bottom memory: 512 MB, 5E
CFLASH5E-256	CompactFlash 256 MB
CFLASH5E-512	CompactFlash 512 MB
CPCI-60206E-MCPTM-01	CPCI-6020 Rear Transition Module
CPCI-6020-MCPTM-01	CPCI-6020 Rear Transition Module, 5E
SIM232DCE6E	Serial Interface Module, EIA-232-D DCE
SIM232DTE6E	Serial Interface Module, EIA-232-D DTE

## 2.1 Overview

This chapter provides startup and safety instructions related to this product, hardware preparation instructions, including: default jumper settings; system considerations, and installation instructions for the baseboard; as well as the PMC, memory mezzanines, and transition module associated with this board.

A fully implemented CPCI-6020 consists of the baseboard plus:

- A single-wide PCI mezzanine card (PMC) for added versatility.
- One or two RAM500 SDRAM memory mezzanines per mezzanine site (two sites available) for a maximum of 2 GB of added memory.
- One CPCI-6020-MCPTM-01 rear transition module for support of the mapped I/O from the CPCI-6020 baseboard to the J3 and J5 CompactPCI connectors.

## 2.2 Unpacking and Inspecting the Board

Read all notices and cautions prior to unpacking the product.

### NOTICE

#### Damage of Circuits

**Electrostatic discharge and incorrect installation and removal can damage circuits or shorten their life.**

**Before touching the AMC or electronic components, make sure that you are working in an ESD-safe environment.**

## Shipment Inspection

To inspect the shipment, perform the following steps:

1. Verify that you have received all items of your shipment.
2. Check for damage and report any damage or differences to customer service.
3. Remove the desiccant bag shipped together with the board and dispose of it according to your country's legislation.



**The product is thoroughly inspected before shipment. If any damage occurred during transportation or any items are missing, contact customer service immediately.**

## 2.3 Overview of Start-up Procedure

The following table lists the things you will need to do before you can use this board and tells you where to find the information you need to perform each step. Be sure to read this entire chapter, including all Caution and Warning notes, before you begin.

*Table 2-1 Startup Overview*

Task	Page
Unpack the hardware.	<a href="#">Chapter 2, <i>Unpacking and Inspecting the Board</i>, on page 35</a>
Configure the hardware by setting jumpers on the boards.	<a href="#">Chapter 2, <i>Jumper Settings</i>, on page 41</a>
Ensure CompactFlash card is installed (if required).	<a href="#">Chapter 2, <i>CompactFlash Memory Card Installation</i>, on page 46</a>
Ensure memory mezzanines are properly installed on the board.	<a href="#">Chapter 6, <i>RAM500 Module Installation</i>, on page 118</a>
Install PMC Module (if required).	<a href="#">Chapter 2, <i>PMC Module Installation</i>, on page 44</a>
Install the CPCI-6020 in the chassis.	<a href="#">Chapter 2, <i>Installing and Removing a Module</i>, on page 51</a>
Install PIM on CPCI-6020-MCPTM-01 (if required)	<a href="#">Chapter 7, <i>Installing the PIM</i>, on page 138</a>
Install peripherals, and any other devices or equipment used.	<a href="#">Appendix A, <i>Manufacturers' Documents</i>, on page 161</a>
Power up the system.	<a href="#">Chapter 2, <i>Hardware Preparation and Installation</i></a>
Ensure that the debugger initializes the CPCI-6020	<a href="#">Chapter 5, <i>Firmware</i></a>

Table 2-1 Startup Overview (continued)

Task	Page
Initialize the system clock.	<a href="#">Chapter 5, Firmware</a>
Examine and/or change environmental parameters.	<a href="#">Chapter 8, CNFG and ENV Commands</a>
Program the board as needed for your applications.	CPCI-6020 CompactPCI Single Board Computer Programmer's Reference Guide Harrier Application Specific Integrated Circuit (ASIC) Programmer's Reference Guide

## 2.4 Equipment Required

The following equipment is recommended to complete an CPCI-6020 system:

- CompactPCI system enclosure (in compliance with CompactPCI Specification, PICMG 2.0, Rev. 2.1)
- System console terminal
- Operating system (and/or application software)
- Disk drives (and/or other I/O) and controllers
- Transition module (CPCI-6020-MCPTM-01) and connecting cables

CPCI-6020 modules are designed with front and rear panel I/O. Front panel I/O includes two USB ports, one Ethernet port (unless run to rear), a UART Port 0 and a PMC I/O port (if a PMC is installed). The rear panel I/O is provided via a CPCI-6020-MCPTM-01 Transition Module and includes two Ethernet ports (only port 2 is connected in standard product configuration. Contact custom solution center for connecting port 1 through custom build options), two USB ports, two UART ports (one may be run to front), and two synchronous COM ports.

## 2.5 Environmental and Power Requirements

You must make sure that the blade, when operated in your particular system configuration, meets the environmental requirements specified in the next section.

### 2.5.1 Environmental Requirements

The following table lists the currently available specifications for the environmental characteristics of the CPCI-6020. A complete functional description of the CPCI-6020 baseboard appears in [Chapter 4, Functional Description](#) .

You must make sure that the board, when operated in your particular system configuration, meets the environmental requirements specified below.



**Operating temperatures refer to the temperature of the air circulating around the board and not to the component temperature.**

*Table 2-2 Specifications*

Characteristics	Operating	Nonoperating
Operating temperature	0°C to +55°C (32°F to 131°F) entry air with forced-air cooling	-40°C to +70° C (104°F to 158°F)
Temperature change	+/-0.5° C/min according to NEBS Standard GR-63-CORE	
Forced Air Flow	250 LFM @ 55°C (131°F ambient temperature)	
Relative humidity	5% to 90%	5% to 90%
Vibration	1.0G sine sweep, 5-200 Hz, .25 octaves/min, all 3 axis (operating)	5-20 Hz @ 0.01 g/Hz 20-200 Hz @ -3.0 dB/octave Random 5-20 Hz @ 1 m/Sec Random 20-200 Hz @ -3 dB/oct
Shock	Half-sine, 11 mSec, 30 m/Sec	Blade level packaging Half-sine, 6 mSec at 180 m/Sec
Free Fall		Blade level packaging 100mm (unpackaged) per GR-63-CORE

## NOTICE

### **Product Damage**

**High humidity and condensation on the board surface causes short circuits.**

**Do not operate the board outside the specified environmental limits.**

**Make sure the board is completely dry and there is no moisture on any surface before applying power.**

## 2.5.2 Power Requirements

The CPCI-6020 module draws +3.3VDC, +5VDC, VIO, +12VDC and -12VDC, with a voltage variation of  $\pm 5\%$  from the standard value, from the CompactPCI backplane connector J1. Typical power consumption of only the CPCI-6020 is approximately 15 W at +5VDC and 9 W at +3.3VDC.

Table 2-3 Baseboard and RTM Power Requirements

Board ID	+3.3 V	+5 V	+12 V
CPCI-6020-500	2.6 A typ	2.8 A typ.	15 mA typ.
	3.5 A max	3.75 A max.	20 mA max.
CPCI-6020-MCPTM-01	0.0 A typ.	50 mA typ	0.0 A typ.
	0.0 A max.	100 mA max.	0.0 A max.

The CPCI-6020 supplies +3.3VDC, +5.0VDC, +12VDC and -12VDC to J3 and J5 for use by the transition module. Separately fused +5VDC is also provided for the keyboard/mouse. Separate +5VDC fused power is also provided for each USB channel and the PMC slot +5VDC.

No more than 0.5 of an amp is allowed per power pin (IEEE 1386.1 specification) on any power connector.

## 2.5.3 Thermal Requirements

The CPCI-6020 module requires a minimum air flow of 250 LFM when operating at a 55°C (131°F) ambient temperature.



Most of the heat is generated by CPU at the top layer. Make sure that there is sufficient airflow to the CPU heatsink.

## 2.6 Hardware Configuration

To produce the desired configuration and ensure proper operation of the CPCI-6020, you may need to carry out certain hardware modifications before installing the module. Some hardware modifications are controlled through manual installation or removal of header jumpers or interface modules on the baseboard or the associated transition module. These modifications are described in the next section.

The CPCI-6020 also provides configuration modification via software control by setting bits in control registers after installing the module in a system. The CPCI-6020 control registers are described in the *CPCI-6020 CompactPCI Single Board Computer Programmer's Reference Guide*, and the *Harrier Application Specific Integrated Circuit (ASIC) Programmer's Reference Guide*.

## 2.7 CPCI-6020 Baseboard Preparation

Prior to installing any memory, flash, or PMC modules on the CPCI-6020 baseboard, ensure that all jumpers that are user configurable are set properly. To do this, refer to [Figure 2-1](#) or the board itself for the location of specific jumpers. Set the jumpers according to the following descriptions. Manually configured items on the baseboard include:

- Flash bank selection (J24)
- Harrier Power up configuration header (J22)
- PMC 66 MHz optional setting (J21)
- Enable/disable +12 V and -12 V use on the CPCI-6020 (J18)
- Enable/disable lockdown of one or more flash blocks of Bank A (J17)
- Enable/disable write-protect for all of flash Bank A (J20)



- Remote switch (J19)
- Jumpers J7 and J25 are only for factory use

Figure 2-1 Header Locations and Jumper Settings

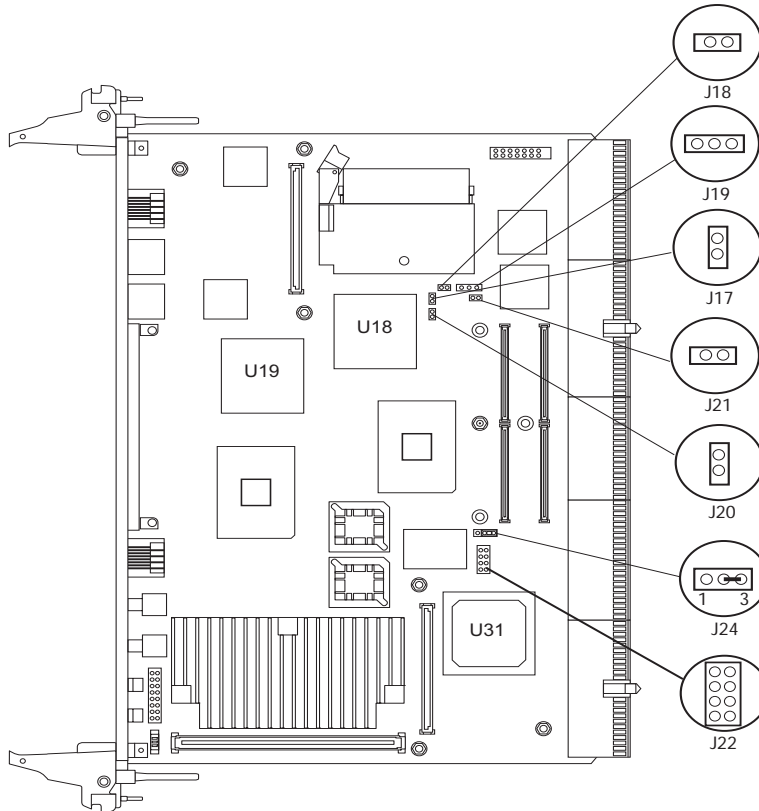

## 2.8 Jumper Settings

The following sections describe the on-board jumpers and their configurations for the CPCI-6020. For jumper locations, see [Figure 2-1](#).

### 2.8.1 Flash Bank Selection

The CPCI-6020 contains one bank of 32 MB 16-bit flash memory soldered on-board (Bank A) and 1 MB of 16-bit socketed flash memory (Bank B). Bank A is 64-bits wide and Bank B is 16-bits wide. Bank B contains the on-board debugger and diagnostics, PPCBug.

To enable Flash Bank A, place a jumper across pins 1 and 2 of header J24. To enable Flash Bank B, place a jumper across pins 2 and 3 of header J24.

J24	Jumper On
1-2	Flash Bank A Enabled (32 MB, soldered)
2-3	Flash Bank B Enabled (1 MB, sockets) Factory Configuration

## 2.8.2 Harrier Power Up Configuration Header

A 2 mm, 8-pin low profile header located on side 1 of the CPCI-6020 provides the means to change some of the Harrier power up configuration settings. The pin assignments for this header, along with the power up setting with the jumper on or off, are as follows (boards are shipped with all jumpers off):

J22	Jumper On	Jumper Off
1-2	PUST0 = 0 Harrier PUST Bit 0 in GCSR Register	PUST0 = 1
3-4	PUST1 = 0 Harrier PUST Bit 1 in GCSR Register	PUST1 = 1
5-6	PUST2 = 0 Harrier PUST Bit 2 in GCSR Register	PUST2 = 1
7-8	PUST3 = 0 Harrier PUST Bit 2 in GCSR Register	PUST3 = 1

## 2.8.3 PMC 66 MHz Disable

This 0.1 inch, 2-pin header (J21) located on the CPCI-6020 is used to disable 66 MHz operation on PCI Bus B. When a jumper is installed between pins 1 and 2, PCI Bus B will operate at 33 MHz regardless of whether the PMC is capable of 66 MHz. This prevents the secondary Ethernet controller from being disabled if a 66 MHz capable PMC is installed. The jumper pulls the M66EN signal low so the PMC can be aware that the bus is operating at 33 MHz.

J21
GND
M66EN

## 2.8.4 Enable/Disable +12 V and -12 V Use

This 0.1 inch, 2-pin header (J18) located on the CPCI-6020 is used to disable +/-12 V on the board.

When using the +12 V and -12 V power disable (J18 jumper is installed), +12 V and -12 V power is not provided to on-board CPCI-6020 electronics or to the rear transition module. This may affect operation of any modules installed, such as: a PMC on the CPCI-6020 or a PIM or SIM on the rear transition module. For example, COM Port 3 and COM Port 4 on the rear transition module will not operate when the J18 jumper is installed. Generally, this jumper should be installed when there is no +/-12 V power coming from the chassis.

## 2.8.5 Enable/Disable Lockdown of One or More Flash Blocks for Bank A

This 0.1 inch, 2-pin header (J17) located on the CPCI-6020 is used to enable lockdown of one or more flash blocks of bank A. When a jumper is installed between pins 1 and 2, one or more blocks of bank A are locked. Blocks in lockdown cannot be unlocked with the **Flash Unlock** command.

## 2.8.6 Enable Write-Protect for Entire Flash on Bank A

This 0.1 inch, 2-pin header (J20) located on the CPCI-6020 is used to enable write-protect for the entire flash on bank A. When a jumper is installed between pins 1 and 2, memory contents cannot be altered in the entire flash.

## 2.8.7 Remote Switch

This 0.1 inch, 3-pin header (J19) located on the CPCI-6020 allows you to connect a remote switch that performs the same function as front panel reset and abort switch. The pin configuration is as follows:

Pin #	Signal
1	Abort
2	GND
3	RESET

## 2.9 Hardware Installation

The following sections discuss the installation of a PMC module on the CPCI-6020 baseboard, the installation of CompactFlash, and the installation of the complete CPCI-6020 assembly into a CompactPCI chassis. Also described are the start-up procedure and system considerations relevant to installation. Before installing the CPCI-6020, ensure that the serial ports and all jumpers are properly configured, refer to [CPCI-6020 Baseboard Preparation on page 40](#) and [Preparing the Transition Module on page 131](#) for serial port configurations.

In most cases, the memory mezzanine card (RAM500) is already in place on the baseboard. The user-configured jumpers are accessible with the mezzanines installed. At least one RAM500 memory mezzanine card must be installed on the CPCI-6020 prior to operation in order for the board to function properly. To install one or more RAM500 memory mezzanine cards, refer to [Chapter 6, RAM500 Memory Expansion Module](#).

Should it be necessary to install a PMC mezzanine on the baseboard, refer to [PMC Module Installation](#) in this chapter for a description of that installation procedure.

### NOTICE

#### Damage of Circuits

Electrostatic discharge and incorrect module installation and removal can damage circuits or shorten their life.

Before touching the module or electronic components, make sure that you are working in an ESD-safe environment.

## 2.10 PMC Module Installation

### Procedure

The PCI mezzanine card (PMC) module mounts beside the RAM500 mezzanine on top of the CPCI-6020 baseboard. To install a PMC module, proceed as follows:

1. Attach an ESD strap to your wrist. Attach the other end of the ESD strap to the chassis as a ground. The ESD strap must be secured to your wrist and to ground throughout the procedure.
2. If the PMC module is being installed in a non-hot swap chassis, perform an operating system shutdown. Turn the AC or DC power off and remove the AC cord or DC power lines from the system. Remove the chassis or system cover(s) as necessary for access to the CompactPCI.

### NOTICE

#### Product Damage

Inserting or removing PMC modules with power applied may result in damage to module components.

Before installing or removing additional devices or modules, read the documentation that came with the product.



### WARNING

#### Personal Injury or Death

Dangerous voltages capable of causing death exist.

To prevent injury, use extreme caution when handling, testing and adjusting this equipment.

3. Carefully remove the CPCI-6020 from the CompactPCI card slot and place it on a clean and adequately protected working surface with connectors J1 through J5 facing you.

### NOTICE

**Product Damage**

**Avoid touching areas of integrated circuitry; static discharge can damage these circuits.**

**Before touching the board or electronic components, make sure you are working in an ESD-safe environment.**

4. Remove the PCI filler from the front panel.
5. Slide the edge connector of the PMC module into the front panel opening from behind and place the PMC module on top of the baseboard. The four connectors on the underside of the PMC module should then connect smoothly with the corresponding connectors (J11/12/13/14) on the CPCI-6020.
6. Insert the four short phillips-head screws (provided with the PMC) through the holes on the bottom side of the CPCI-6020 and the PMC front bezel and into rear standoffs. Tighten the screws.
7. Reinstall the CPCI-6020 assembly in its proper card slot. Be sure the module is well seated in the backplane connectors. Do not damage or bend connector pins.
8. If the PMC module was installed in a non-hot swap chassis, replace the chassis or system cover(s), reconnect the system to the AC or DC power source and turn the equipment power on.

## 2.11 CompactFlash Memory Card Installation

### Procedure

The CompactFlash memory card mounts on the CPCI-6020 baseboard. To upgrade or install a CompactFlash memory card, refer to the next figure and proceed as follows:

1. Attach an ESD strap to your wrist. Attach the other end of the strap to the chassis (for proper grounding). The ESD strap must be secured to your wrist and to chassis ground throughout the procedure.
2. If you are installing the board in a non-hot swap chassis, perform an operating system shutdown. Turn the AC or DC power off and remove the AC cord or DC power lines from the system. Remove the chassis or system cover(s) as necessary to access the compact PCI module.

### NOTICE

#### Board Damage

Inserting or removing modules that are not HA capable with power applied may result in damage to module components.

Verify that your board is HA capable.



### WARNING

#### Personal Injury

Dangerous voltages capable of causing death exist.

To prevent injury, use extreme caution when handling, testing and adjusting this equipment.

3. Carefully remove the CPCI-6020 from the CompactPCI card slot and place it on a clean and adequately protected working surface with connectors J1 through J5 facing you.

### NOTICE

#### Product Damage

Avoid touching areas of integrated circuitry; static discharge can damage these circuits.

Before touching the board or electronic components, make sure you are working in an ESD-safe environment.

- Slide the CompactFlash memory card into the J15 connector and make sure that pin 1 of the card aligns with pin 1 of J15.

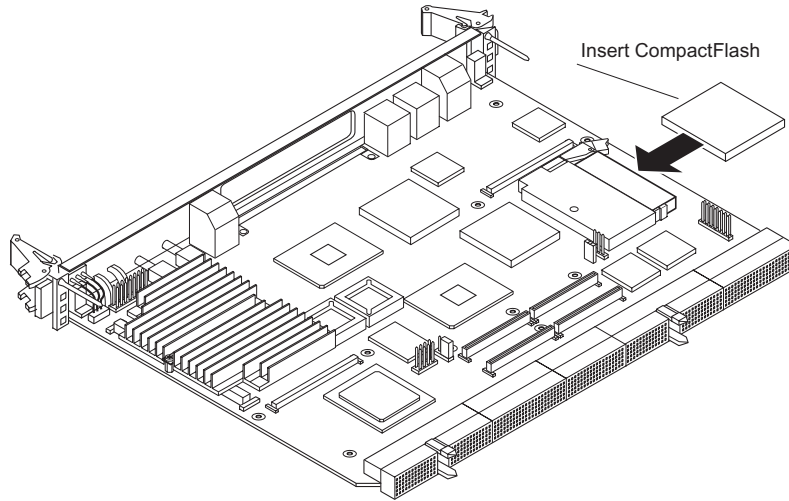

- If you are installing RAM500 memory cards or a PMC module on this board, follow the installation instructions in [Chapter 6, RAM500 Memory Expansion Module, on page 117](#) and [PMC Module Installation on page 44](#). If not, read the next section and then reinstall the CPCI-6020 assembly in the proper card slot. Check that the board is properly seated in the backplane connectors. Take care not to damage or bend connector pins.

## 2.12 Before You Install or Remove a Board

Boards may be damaged if improperly installed or handled. Please read and follow the guidelines in this section to protect your equipment.

### NOTICE

#### Damage of Circuits

Electrostatic discharge and incorrect board installation and removal can damage circuits or shorten their life

Before touching the board or electronic components make sure that you are working in an ESD-safe environment.

## 2.12.1 Watch for Bent Pins or Other Damage

### NOTICE

**Product Damage**

**Bent pins or loose components can cause damage to the board, the backplane or other system components.**

**Carefully inspect your board and the backplane for both pin and component integrity before installation.**

ECC and our suppliers take significant steps to ensure there are no bent pins on the backplane or connector damage to the boards prior to leaving our factory. Bent pins caused by improper installation or by boards with damaged connectors could void the ECC warranty for the backplane or boards.

If a system contains one or more crushed pins, power off the system and contact your local sales representative to schedule delivery of a replacement chassis assembly.

## 2.12.2 Use Caution When Installing or Removing Boards

### NOTICE

**Product Damage**

**Bent pins or loose components can cause damage to the board, the backplane or other systems.**

**Carefully inspect your board and the backplane for both pin and component integrity before installation.**

When first installing boards in an empty chassis, we recommend that you start at the left of the card cage and work to the right when cards are vertically aligned; in horizontally aligned cages, work from bottom to top.

When inserting or removing a board in a slot adjacent to other boards, use extra caution to avoid damage to the pins and components located on the primary or secondary sides of the boards.

## 2.12.3 Understanding Hot Swap

The PICMG 2.1 Hot Swap specification defines varying levels of hot swap. A board that is compliant with the specification can be inserted and removed safely with system power on without damage to on-board circuitry. **If a module is not hot swap compliant, you should remove power to the slot or system before inserting or removing the module.**



The CPCI-6020 does not support a hot swap LED. You may need to manually shut down applications or operating systems running on the board prior to board removal.

### NOTICE

#### Data Loss

**Powering down or removing a board before the operating system or other software running on the board has been properly shut down may cause corruption of data or file systems.**

**Make sure all software is completely shut down before removing power from the board or removing the board from the chassis.**

Refer to the documents listed in [Appendix A, Related Documentation](#) for more information about hot swap and the PCI Industrial Computer Manufacturers Group (PICMG) Hot Swap Specification.

## 2.12.4 Recognize Different Injector/Ejector Lever Types

The modules you install may have different ejector handles and latching mechanisms. The following illustration shows the typical board ejector handles used with ECC payload cards: (A) Elma Latching, (B) Rittal Type II, (C) Rittal Type IV. All handles are compliant with the CompactPCI specification and are designed to meet the IEEE1101.10 standards.

Figure 2-2 Injector/Ejector Lever Types

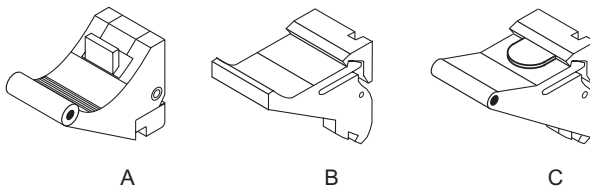

Each lever type has a latching mechanism to prevent the lever from being opened accidentally. You must press the lever release before you can open the lever. **Never force the lever.** If the lever does not open easily, you may not have pressed firmly enough on the release. If the lever does not close easily, the board may not be properly seated in the chassis.

- To open a lever, press the release and move the lever outward away from the face plate.
- To close a lever, move the lever inward toward the face plate until the latch engages.

## 2.12.5 Verify Slot Usage

### NOTICE

#### Product Damage





Prevent possible damage to module components by verifying the proper slot usage for your configuration.

Check the icons and colored card rails for slot purpose prior to installing a module.

In most cases, connector keying will prevent insertion of a board into an incompatible slot. However, as an extra precaution, you should be familiar with the glyphs and colored card rails used to indicate slot purpose.

The following table lists the colors and glyphs common to ECC chassis.

Table 2-4 Slot Usage Indicators

Card Rail Color	Glyph	Usage
Tan	none	MXP: Alarm Management Controller slot
		CPX: Hot Swap Controller or Bridge slot
Red		MXP: Fabric Switch Card slot
		CPX: System Controller slot
Black		MXP: Payload Card slot
		CPX: Non-system Controller or I/O Card slot

## 2.12.6 Preserve EMI Compliance

### NOTICE

#### Preserve EMI Compliance

To preserve compliance with applicable standards and regulations for electromagnetic interference (EMI), during operation all front and rear openings on the chassis or board face plates must be filled with an appropriate card or covered with a filler panel. If the EMI barrier is open, devices may cause or be susceptible to excessive interference.

## 2.13 Installing and Removing a Module

This section describes a recommended procedure for installing and removing a board module in a chassis. Before you install your module, please read all cautions, warnings and instructions presented in this section and the guidelines explained in [Before You Install or Remove a Board on page 47](#).

### Installation Procedure

Hot swap compliant modules may be installed while the system is powered on. If a module is not hot swap compliant, you should remove power to the slot or system before installing the module. See [Understanding Hot Swap on page 48](#) for more information.

#### **NOTICE**

##### **Signaling Requirements**

**Ensure the backplane does not bus J3, J4 or J5 signals to other slots.**

**Set the VIO on the backplane to either +3.3 V or +5 V, depending upon your system's signaling requirements.**

Refer to the following illustration and perform these steps when installing modules. Note that this illustration is for general reference only and may not accurately depict the connectors and handles on the board you are installing.

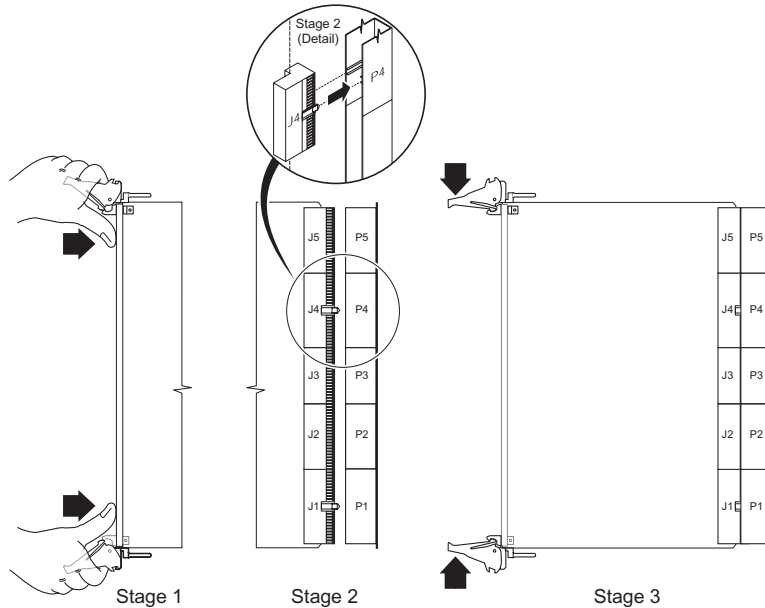

1. Open the injector levers on your board (see [Recognize Different Injector/Ejector Lever Types on page 49](#)).
2. Verify the proper slot for the module you are inserting (see [Verify Slot Usage on page 50](#)). Align the edges of the module with the card cage rail guides in the appropriate slot. Insert the board by holding the injector levers, do not exert unnecessary pressure on the face plate.
3. Using your thumbs, apply equal and steady pressure as necessary to carefully slide the module into the card cage rail guides (Stage 1). Continue to gently push until the prealignment guide pegs engage with the backplane connector (Stage 2) and the injector levers make contact with the chassis rails. Do not force the board into the backplane slot.
4. Use the injector levers to seat the module in the slot by closing the levers until they latch into the locked position (Stage 3). If the levers do not completely latch, remove the module from the chassis and visually inspect the slot to ensure there are no bent pins.
5. When the module you are installing is completely latched, secure it by tightening the captive screws at both ends of the face plate.

This section describes a recommended procedure for removing a board module from a chassis.

Before you remove your module, please read all cautions, warnings and instructions presented in this section and the guidelines explained in [Before You Install or Remove a Board on page 47](#).

Hot swap compliant modules may be removed while the system is powered on. If a module is not hot swap compliant, you should remove power to the slot or system before removing the module. See [Understanding Hot Swap on page 48](#) for more information.

## NOTICE

### Data Loss

Powering down or removing a board before the operating system or other software running on the board has been properly shut down may cause corruption of data or file systems.

Make sure all software is completely shut down before removing power from the board or removing the board from the chassis.

## Removal Procedure

To remove a board module, follow these steps:

1. Loosen the module's captive screws at both ends of the front panel.
2. Begin to remove your module by unlatching the ejector lever (the lower lever on vertically mounted boards). See [Recognize Different Injector/Ejector Lever Types on page 49](#). **Do not remove the module immediately.**
3. Once the applications and operating system running on the board have stopped and it is safe to remove the board, open both ejector levers to partially unseat the module from the backplane connectors.

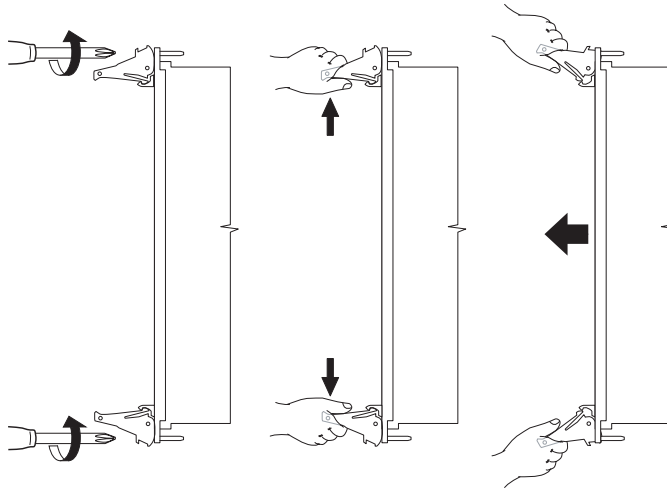

If your module is hot swap compliant and you are running fully functional hot swap-aware software, unlatching this ejector lever will start the shutdown process on the board.

4. Carefully pull the module from the chassis.

## 2.14 Startup and Operation

This section describes startup information used with the CPCI-6020 family of single board computers in a system configuration. The information includes system considerations, a brief explanation and graphic of the power-up sequence performed by the firmware.

### Power-up Procedure

Perform the following steps to ensure proper board operation:

1. Before applying power, ensure you configure the hardware properly (for example, jumper settings, memory installation, flash installation, PMC installation and other hardware features).
2. Check all connections and ensure the installation is complete (cabling, transition module connections, if applicable).
3. Once everything is verified, power up the system.

When the power is turned on, the MPU, the hardware and the firmware initialization processes are performed. The firmware initializes the devices on the CPCI-6020 in preparation for booting the operating system.

The firmware is shipped from the factory with an appropriate set of defaults. In most cases, it is not necessary to modify the firmware configuration before booting the operating system.

The following flowchart shows the basic initialization process that takes place during system startup. Refer to a detailed initialization list in [Chapter 5, Firmware, on page 107](#).

Figure 2-3 Start Up Flow Diagram

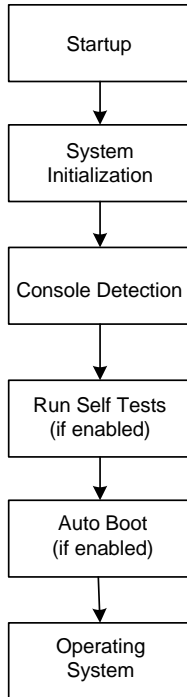

## 2.15 System Considerations

The CPCI-6020 is designed to operate as a CompactPCI system slot board. As a system slot board, the CPCI-6020 provides system clocks and arbitration for other peripheral slots in the subrack. Consequently, the CPCI-6020 must be installed in a subrack system slot marked with a triangle symbol.

The CPCI-6020 provides seven peripheral slot clock outputs (CLK0-CLK6) per CompactPCI specification 2.0 R2.1. Arbitration for the seven peripheral slot bus masters is provided by the CPCI-6020.

On the CPCI-6020 baseboard, the standard serial console port (COM1) serves as the PPCBug debugger console port. The firmware console should be set up as follows:

- Eight bits per character
- One stop bit per character
- Parity disabled (no parity)
- Baud rate of 9600 baud

A default baud rate of 9600 is used for serial ports on CPCI-6020 boards. After power-up, the baud rate can be changed using the PPCBug PF (Port Format) command via the command line interface. Whatever the baud rate, some type of hardware handshaking; either XON/OFF or via the RTS/CTS line is desirable if the system supports it.



## 3.1 Overview

This chapter summarizes the controls, LEDs, and pin assignments for the CPCI-6020 baseboard. Controls, LEDs, and pin assignments for the CPCI-6020-MCPTM-01 transition module and RAM500 memory modules can be found in [Chapter 7, Transition Module Preparation and Installation](#) and [Chapter 6, RAM500 Memory Expansion Module](#) respectively.

## 3.2 CPCI-6020 Baseboard Layout

The next figure illustrates the placement of the headers, connectors and LED indicators on the CPCI-6020.

Figure 3-1 Headers, Connectors and LEDs

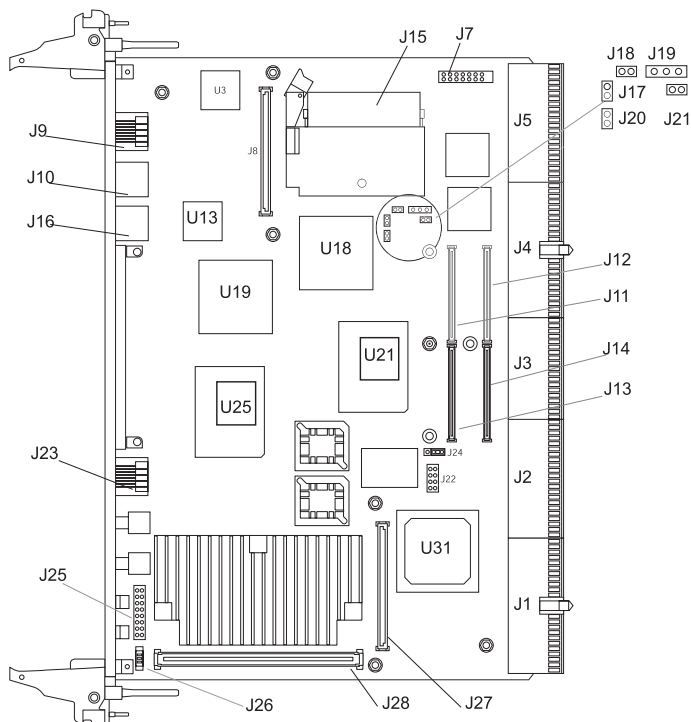

### 3.3 Front Panel Connectors and LEDs

The CPCI-6020 front panel provides access to recessed Abort and Reset push-button switches, Board Fail, and CPU Bus Activity LEDs, an RJ-45 Ethernet connector, an RJ-45 serial port connector, two USB connectors and the PMC front panel.

This section describes the baseboard connectors and LEDs.

Figure 3-2 Front Panel Connectors and LEDs

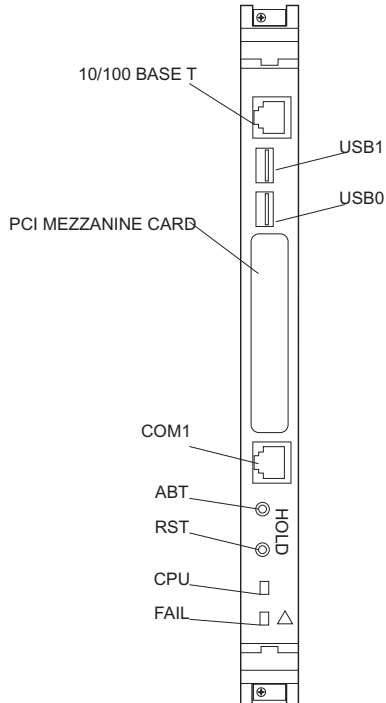

#### 3.3.1 Front Panel Ethernet Port

A 10BaseT/100BaseTx RJ-45 receptacle is located on the front panel of the CPCI-6020 to provide Ethernet I/O. The pin assignments for this connector are:

Table 3-1 Ethernet Connector Pin Assignments

Pin	Signal
1	TD+
2	TD-
3	RD+
4	AC Terminated
5	AC Terminated

Table 3-1 Ethernet Connector Pin Assignments (continued)

Pin	Signal
6	RD-
7	AC Terminated
8	AC Terminated

### 3.3.2 Front Panel Asynchronous Serial Port

An RJ-45 receptacle is located on the front panel of the CPCI-6020 to provide the interface to the COM1 serial port. This port is configured as DCE. The pin assignments for this connector is as follows:

Table 3-2 COM1 Pin Assignments

Signal	Pin
1	DCD
2	RTS
3	GND
4	TXD
5	RXD
6	GND
7	CTS
8	DTR

### 3.3.3 Front Panel USB ports

There are two USB Series A receptacles located on the front panel of the CPCI-6020. The pin assignments are shown in the next tables:

Table 3-3 USB Port 1

Pin Number	Pin Name
1	USBVOUT1
2	USB1DATA_N
3	USB1DATA_P
4	GND

Table 3-4 USB Port 0

Pin Name	Pin Number
1	USBVOUT0
2	USB0DATA_N

Table 3-4 USB Port 0 (continued)

Pin Name	Pin Number
3	USB0DATA_P
4	GND

### 3.3.4 ABORT# Switch

The ABORT# switch is recessed to reduce the likelihood of accidental activation. The ABORT# signal is connected to the Harrier Abort Switch (ABTSW\_L) input and generates an MPIC internal interrupt. This signal is debounced in the Harrier ASIC.

### 3.3.5 RESET# Switch

The RESET# switch is recessed to reduce the likelihood of accidental activation. The signal is connected to the Harrier Reset Switch (RSTSW\_L) input which will generate a Harrier Reset Out, which is ORed with the board reset logic. This signal is debounced in the Harrier ASIC.

### 3.3.6 Front Panel LEDs

The CPCI-6020 provides these LEDs on the front panel. Refer to the *Harrier Application Specific Integrated Circuit (ASIC) Programmer's Reference* guide for details of the BDFL bit.

Table 3-5 Front Panel LEDs

LED/Color	Description	Status
CPU/green	Illuminated	Processor bus active
	Extinguished	Processor bus inactive
BDFL/yellow	Illuminated	BDFL bus active
	Extinguished	BDFL bus inactive

## 3.4 Connector Pin Assignments

The following tables describe connectors available on the CPCI-6020 base board. Note that the pin assignments for connectors J3, J4 and J5 apply to the transition module, as well as the CPCI-6020.

### 3.4.1 CompactPCI Bus Connectors

The CPCI-6020 implements a 64-bit CompactPCI interface on connectors J1 and J2. Each of these connectors conform to the CompactPCI specification. The pinout for connectors J1 and J2 are shown in [Table 3-6 on page 61](#) below and [Table 3-7 on page 61](#).

- J1 is a 110 pin AMP Z-pack 2 mm hard metric type A connector with keying for +3.3 V or +5 V
- J2 is a 110 pin AMP Z-pack 2 mm hard metric type B connector

Pin D15 of J1 is used in peripheral slots for the BD\_SEL# signal supporting hot swap. In the system slot, this pin is defined as GND. The CPCI-6020 interprets this pin as BD\_SEL\_L. In a non-High Availability (HA) chassis, this signal is GND (always asserted) and hence this usage is backwardly compatible.

Table 3-6 J1 CompactPCI Connector

Pin	Row A	Row B	Row C	Row D	Row E	Pin
25	+5 V	REQ64_L	ENUM_L	+3.3 V	+5 V	25
24	AD1	+5 V	VIO	AD0	ACK64_L	24
23	+3.3 V	AD4	AD3	+5 V	AD2	23
22	AD7	GND	+3.3 V	AD6	AD5	22
21	+3.3 V	AD9	AD8	GND	CBE0_L	21
20	AD12	GND	VIO	AD11	AD10	20
19	+3.3 V	AD15	AD14	GND	AD13	19
18	SERR_L	GND	+3.3 V	PAR	CBE1_L	18
17	+3.3 V	No Connect (SDONE)	No Connect (SBO_L)	GND	PERR_L	17
16	DEVSEL_L	GND	VIO	STOP_L	No Connect (LOCK_L)	16
15	+3.3 V	FRAME_L	IRDY_L	BD_SEL_L	TRDY_L	15
12 -14	KEY AREA					12 -14
11	AD18	AD17	AD16	GND	CBE2_L	11
10	AD21	GND	+3.3 V	AD20	AD19	10
9	CBE3_L	IDSEL	AD23	GND	AD22	9
8	AD26	GND	VIO	AD25	AD24	8
7	AD30	AD29	AD28	GND	AD27	7
6	REQ_L	GND	+3.3 V	CLK	AD31	6
5	No Connect (BRSVP1A5)	No Connect (BRSVP1B5)	RST_L	GND	GNT_L	5
4	No Connect (BRSVP1A4)	HEALTHY_L	VIO	No Connect (INTP)	No Connect (INTS)	4
3	INTA_L	INTB_L	INTC_L	+5 V	INTD_L	3
2	TCK	+5 V	TMS	TDO	TDI	2
1	+5 V	-12 V	TRST_L	+12 V	+5 V	1

Table 3-7 J2 CompactPCI Connector

Pin	Row A	Row B	Row C	Row D	Row E	Pin
22	GA4	GA3	GA2	GA1	GA0	22

Table 3-7 J2 CompactPCI Connector (continued)

Pin	Row A	Row B	Row C	Row D	Row E	Pin
21	No Connect (CLK6)	GND	No Connect (RSV)	No Connect (RSV)	No Connect (RSV)	21
20	No Connect CLK5	GND	No Connect (RSV)	GND	No Connect (RSV)	20
19	GND	GND	No Connect (RSV)	No Connect (RSV)	No Connect (RSV)	19
18	No Connect BRSVP2A18	No Connect BRSVP2B18	No Connect BRSVP2C18	GND	No Connect BRSVP2E18	18
17	No Connect BRSVP2A17	GND	No Connect (PRST_L)	No Connect (REQ6_L)	No Connect (GNT6_L)	17
16	No Connect BRSVP2A16	No Connect BRSVP2B16	No Connect (DEG_L)	GND	No Connect (BRSVP2E16)	16
15	No Connect BRSVP2A15	GND	No Connect (FAL_L)	No Connect (REQ5_L)	No Connect (GNT5_L)	15
14	AD35	AD34	AD33	GND	AD32	14
13	AD38	GND	VIO	AD37	AD36	13
12	AD42	AD41	AD40	GND	AD39	12
11	AD45	GND	VIO	AD44	AD43	11
10	AD49	AD48	AD47	GND	AD46	10
9	AD52	GND	VIO	AD51	AD50	9
8	AD56	AD55	AD54	GND	AD53	8
7	AD59	GND	VIO	AD58	AD57	7
6	AD63	AD62	AD61	GND	AD60	6
5	CBE5_L	64EN-L	VIO	CBE4_L	PAR64	5
4	VIO	No Connect BRSVP2B4	CBE7_L	GND	CBE6_L	4
3	No Connect (CLK4)	GND	No Connect (GNT3_L)	No Connect (REQ4_L)	No Connect (GNT4_L)	3
2	No Connect (CLK2)	No Connect (CLK3)	No Connect (SYSEN_L)	No Connect (GNT2_L)	No Connect (REQ3_L)	2
1	No Connect (CLK1)	GND	No Connect (REQ1_L)	No Connect (GNT1_L)	No Connect REQ2_L	1

### 3.4.2 CompactPCI User I/O Connector

Connector J3 is a 110 pin AMP Z-pack 2 mm hard metric type B connector. This connector routes the I/O signals for the PMC I/O, serial port and USB ports. The pin assignments for J3 on the processor board and on the transition module are shown in [Table 3-8](#) below (outer row F is assigned and used as ground pins but is not shown in the table):

*Table 3-8 J3 CompactPCI User I/O Connector*

Pin	Row A	Row B	Row C	Row D	Row E	Pin
19	RESERVED	+12 V	-12 V	RXD3	RXD4	19
18	HSC_REQ_L	GND	RSC3	GND	RXC4	18
17	HSC_GNT_L	MXCLK	MXDI	MXSYNC_L	MXDO	17
16	HSC_FLOAT	GND	TXC3	GND	TXC4	16
15	HSC_EJECT_L	RESERVED	RESERVED	TXD3	TXD4	15
14	+3.3 V	+3.3 V	+3.3 V	+5 V	+5 V	14
13	PMCIO5	PMCIO4	PMCIO3	PMCIO2	PMCIO1	13
12	PMCIO10	PMCIO9	PMCIO8	PMCIO7	PMCIO6	12
11	PMCIO15	PMCIO14	PMCIO13	PMCIO12	PMCIO11	11
10	PMCIO20	PMCIO19	PMCIO18	PMCIO17	PMCIO16	10
9	PMCIO25	PMCIO24	PMCIO23	PMCIO22	PMCIO21	9
8	PMCIO30	PMCIO29	PMCIO28	PMCIO27	PMCIO26	8
7	PMCIO35	PMCIO34	PMCIO33	PMCIO32	PMCIO31	7
6	PMCIO40	PMCIO39	PMCIO38	PMCIO37	PMCIO36	6
5	PMCIO45	PMCIO44	PMCIO43	PMCIO42	PMCIO41	5
4	PMCIO50	PMCIO49	PMCIO48	PMCIO47	PMCIO46	4
3	PMCIO55	PMCIO54	PMCIO53	PMCIO52	PMCIO51	3
2	PMCIO60	PMCIO59	PMCIO58	PMCIO57	PMCIO56	2
1	PMCVIO	PMCIO64	PMCIO63	PMCIO62	PMCIO61	1

[Table 3-9 on page 63](#) shows the signal descriptions for the J3 Connector:

*Table 3-9 Signal Descriptions for the J3 Connector*

Pin	Definition
RXDn	Receive Data
TXDn	Transmit data
RXCn	Synchronous channel receive clock
TXCn	Synchronous channel transmit clock
MXCLK	Clock for multiplexed data containing synchronization port control signals.
MXDI	Multiplexed data input

### 3.4.3 CompactPCI User I/O Connector

Connector J4 is a 110 pin AMP Z-pack 2 mm hard metric type B connector. This connector routes the PCI bus of Harrier A to hot swap controller bridge board. The pin assignments for J4 on the processor board are shown in [Table 3-10](#) (outer row F is assigned and used as ground pins but is not shown in the table).

*Table 3-10 J4 Local PCI Expansion Connector Pinout*

Pin	Row A	Row B	Row C	Row D	Row E	Pin
25	AD36	AD35	AD34	AD33	AD32	25
24	AD40	AD39	AD38	GND	AD37	24
23	AD45	AD44	AD43	AD42	AD41	23
22	AD49	+3.3 V	AD48	AD47	AD46	22
21	AD53	AD52	AD51	GND	AD50	21
20	AD57	+3.3 V	AD56	AD55	AD54	20
19	AD61	AD60	AD59	GND	AD58	19
18	CBE4#	+3.3 V	PAR64	AD63	AD62	18
17	REQ64#	CBE7#	CBE6#	GND	CBE5#	17
16	AD2	+3.3 V	AD1	AD0	ACK64#	16
15	AD6	AD5	AD4	GND	AD3	15
11	AD9	AD8	CBE0#	GND	AD7	11
10	AD13	+5.0V	AD12	AD11	AD10	10
9	PAR	CBE1#	AD15	GND	AD14	9
8	STOP#	+5.0V	LOCK#	PERR#	SERR#	8
7	FRAME#	IRDY#	TRDY#	GND	DEVSEL#	7
6	AD18	+5.0V	AD17	AD16	CBE2#	6
5	AD21	CLK	AD20	GND	AD19	5
4	CBE3#	+5.0V	RESERVED	AD23	AD22	4
3	AD28	AD27	AD26	AD25	AD24	3
2	GNT#	REQ#	AD31	AD30	AD29	2
1	INTA#	INTB#	INTC#	INTD#	RST#	1



### 3.4.4 CompactPCI User I/O Connector

Connector J5 is a 110 pin AMP Z-pack 2 mm hard metric type B connector. This connector routes the I/O signals for the two COM ports, the IDE secondary port, the keyboard, the mouse, the two USB ports and the two ethernet ports. [Table 3-11](#) show the pin assignments (row F is assigned as ground pins but is not shown in the table) and [Table 3-12](#) describes the signals:

Table 3-11 J5 User I/O Connector

Pin	Row A	Row B	Row C	Row D	Row E	Pin
22	RESERVED	GND	RESERVED	+5.0 V	SPKROC_L	22
21	KBDDAT	KBDCLK	KBAUXVCC	AUXDAT	AUXCLK	21
20	RESERVED	RESERVED	RESERVED	GND	RESERVED	20
19	RESERVED	GND	UVCC0	UDATA0+	UDATA0-	19
18	RESERVED	UDATA1+	UDATA1-	GND	UVCC1	18
17	RESERVED	ENET1_T+	ENET2_T+	ENET1_R+	ENET2_R+	17
16	RESERVED	ENET1_T-	ENET2_T-	ENET1_R-	ENET2_R-	16
15	RESERVED	RESERVED	RESERVED	RESERVED	RESERVED	15
14	RTSa	CTSa	Rl <sub>a</sub>	GND	DTR <sub>a</sub>	14
13	DCD <sub>a</sub>	+5.0 V	RXD <sub>a</sub>	DSR <sub>a</sub>	TXD <sub>a</sub>	13
12	RTS <sub>b</sub>	CTS <sub>b</sub>	Rl <sub>b</sub>	5.0V	DTR <sub>b</sub>	12
11	DCD <sub>b</sub>	GND	RXD <sub>b</sub>	DSR <sub>b</sub>	TXD <sub>b</sub>	11
10	TR0_L	WPROT_L	RDATA_L	HDSEL_L	DSKCHG_L	10
9	MTR1_L	DIR_L	STEP_L	WDATA_L	WGATE_L	9
8	RESERVED	INDEX_L	MTR0_L	DS1_L	DS0_L	8
7	CS1FX_L	CS3FX_L	DA1	RESERVED	RESERVED	7
6	RESERVED	GND	RESERVED	DA0	DA2	6
5	DMARQ	IORDY	DIOW_L	DMACK_L	DIOR_L	5
4	DD14	DD0	GND	DD15	INTRQ	4
3	DD3	DD12	DD2	DD13	DD1	3
2	DD9	DD5	DD10	DD4	DD11	2
1	RESET_L	DRESET_L	DD7	DD8	DD6	1

Table 3-12 J5 Signal Descriptions

Signal	Description
AUXCLK	Clock for the PS/2 auxiliary device (mouse)
AUXDAT	Serial data line for PS/2 auxiliary device (mouse)
CS1FX_L	Chip-select drive 0 or command register block select.
CS3FX_L	Chip select drive 1 or command register block select.
CTS <sub>n</sub>	Clear to send

Table 3-12 J5 Signal Descriptions (continued)

Signal	Description
DA (2:0)	Drive register and data port address lines.
DCDn	Data carrier detected
DD (15:0)	Data lines
DIOR_L	I/O read
DIOW_L	I/O write
DIR_L	Controls the direction of the floppy head reader.
DMACK_L	DMA acknowledge
DMARQ	DMA Request
DRESET_L	Reset signal to drive
DS (1:0)	Select disk drives
DSKCHG_L	Indicates drive door has been opened
DSRn	Data set ready
DTRn	Data terminal ready
EIDE port (ATA-2), TTL Levels	
ENETn_R-	Low side of differential receive data
ENETn_R+	High side of differential receive data
ENETn_T-	Low side of differential transmit data
ENETn_T+	High side of differential transmit data
Ethernet Ports 1 & 2:	
Floppy Disk, TTL levels:	
HDSEL_L	Selects the top or bottom head
INDEX_L	Indicates the beginning of track
INTRQ	Drive the interrupt request.
IORDY	Indicates the drive ready for I/O
KBAUXVCC	Fused power for the keyboard and auxiliary device.
KBDDAT	Clock for the PC/AT or PS/2 keyboard
Keyboard/Auxiliary Device TTL:	
MTR (1:0)	Enable/ Disable motor
RDATA_L	Data read
RESET_L	Board hard reset output, TTL
Rin	Ring indicator
RTSn	Request to send
RXDn	Serial receive data
Serial COM Ports (a & b), RS-232 levels:	
SPKROC_L	PC/AT Speaker output, open collector
STEP_L	Step head

Table 3-12 J5 Signal Descriptions (continued)

Signal	Description
TR0_L	Track 0 indicator
TXDn	Serial transmit data
UDATA-	Low signal of differential data for USB channel
UDATA+	High signal of differential data for USB channel
Universal Serial Bus (USB 0 & 1), USB levels	
UVCCn	Fused power for USB channel.
WDATA_L	Write data
WGATE_L	Enables the head write circuitry
WPROT_L	Indicates the disk is write protected.

### 3.4.5 Memory Mezzanine Connectors

Table 3-13 on page 67 shows the pin assignments for the two 140-pin AMP 0.6 mm Free Height mating connectors, which provide a memory expansion capability and include common ground contacts that mate.

Table 3-13 J8 and J27 Memory Mezzanine Connector

Pin	Pin Name	Pin Name	Pin	Pin	Pin Name	Pin Name	Pin
1	GND *	GND *	2	73	DQ56	DQ57	74
3	DQ00	DQ01	4	75	DQ58	DQ59	76
5	DQ02	DQ03	6	77	DQ60	DQ61	78
7	DQ04	DQ05	8	79	GND *	GND *	80
9	DQ06	DQ07	10	81	DQ62	DQ63	82
11	+3.3 V	+3.3 V	12	83	CKD00	CKD01	84
13	DQ08	DQ09	14	85	CKD02	CKD03	86
15	DQ10	DQ11	16	87	CKD04	CKD05	88
17	DQ12	DQ13	18	89	+3.3 V	+3.3 V	90
19	DQ14	DQ15	20	91	CKD06	CKD07	92
21	GND *	GND *	22	93	BA1	BA0	94
23	DQ16	DQ17	24	95	A12	A11	96
25	DQ18	DQ19	26	97	A10	A09	98
27	DQ20	DQ21	28	99	GND *	GND *	100
29	DQ22	DQ23	30	101	A08	A07	102
31	+3.3 V	+3.3 V	32	103	A06	A05	104
33	DQ24	DQ25	34	105	A04	A03	106
35	DQ26	DQ27	36	107	A02	A01	108
37	DQ28	DQ29	38	109	+3.3 V	+3.3 V	110

Table 3-13 J8 and J27 Memory Mezzanine Connector (continued)

Pin	Pin Name	Pin Name	Pin	Pin	Pin Name	Pin Name	Pin
39	DQ30	DQ31	40	111	A00	CS_C0_L	112
41	GND *	GND *	42	113	CS_E0_L	GND*	114
43	DQ32	DQ33	44	115	CS_C1_L	CS_E1_L	116
45	DQ34	DQ35	46	117	WE_L	RAS_L	118
47	DQ36	DQ37	48	119	GND *	GND *	120
49	DQ38	DQ39	50	121	CAS_L	+3.3 V	122
51	+3.3 V	+3.3 V	52	123	+3.3 V	DQMB0	124
53	DQ40	DQ41	54	125	DQMB1	SCL	126
55	DQ42	DQ43	56	127	SDA	A1_SPD	128
57	DQ44	DQ45	58	129	A0_SPD	MEZZ1_L	130
59	DQ46	DQ47	60	131	MEZZ2_L	GND	132
61	GND *	GND *	62	133	GND	SDRAMCLK1	134
63	DQ48	DQ49	64	135	SDRAMCLK3	+3.3 V	136
				137	SDRAMCLK4	SDRAMCLK2	138
67	DQ52	DQ53	68	139	GND *	GND *	140
69	+3.3 V	+3.3 V	70				
71	DQ54	DQ55	72				

### 3.4.6 PCI Mezzanine Card (PMC) Connectors

There are four 64-pin EIA E700 AAAB SMT connectors on the CPCI-6020 to provide the 64-bit (2x32) PCI interface and optional I/O interface to the PMC, J11 through J14. The following table shows the J11 pin assignments:

Table 3-14 PMC Connector J11 Pin Assignments

Pin	Signal	Signal	Pin
1	TCK	-12 V	2
3	GND	INTA#	4
5	INTB#	INTC#	6
7	PRESENT#	+5 V	8
9	INTD#	PCI_RSVD	10
11	GND	PCI_RSVD	12
13	CLK	GND	14
15	GND	GNT#/XREQ0#	16
17	REQ#/XGNT0#	+5 V	18
19	VIO	AD31	20
21	AD28	AD27	22

Table 3-14 PMC Connector J11 Pin Assignments (continued)

Pin	Signal	Signal	Pin
23	AD25	GND	24
25	GND	C/BE3#	26
27	AD22	AD21	28
29	AD19	+5 V	30
31	VIO	AD17	32
33	FRAME#	GND	34
35	GND	IRDY#	36
37	DEVSEL#	+5 V	38
39	GND	LOCK#	40
41	SDONE#	SBO#	42
43	PAR	GND	44
45	VIO	AD15	46
47	AD12	AD11	48
49	AD09	+5 V	50
51	GND	C/BE0#	52
53	AD06	AD05	54
55	AD04	GND	56
57	VIO	AD03	58
59	AD02	AD01	60
61	AD00	+5 V	62
63	GND	REQ64#	64

The following table shows the pin assignments for J12.

Table 3-15 J12 PMC Connector J12 Pin Assignments

Pin	Signal	Signal	Pin
1	+12 V	TRST#	2
3	TMS	TDO	4
5	TDI	GND	6
7	GND	PCI_RSVD	8
9	PCI_RSVD	PCI_RSVD	10
11	MOT_RSVD	+3.3 V	12
13	RST#	MOT_RSVD	14
15	+3.3 V	MOT_RSVD	16
17	PCI_RSVD	GND	18
19	AD30	AD29	20

Table 3-15 J12 PMC Connector J12 Pin Assignments (continued)

Pin	Signal	Signal	Pin
21	GND	AD26	22
23	AD24	+3.3 V	24
25	IDSEL	AD23	26
27	+3.3 V	AD20	28
29	AD18	GND	30
31	AD16	C/BE2#	32
33	GND	IDSELB	34
35	TRDY#	+3.3 V	36
37	GND	STOP#	38
39	PERR#	GND	40
41	+3.3 V	SERR#	42
43	C/BE1#	GND	44
45	AD14	AD13	46
47	M66EN	AD10	48
49	AD08	+3.3 V	50
51	AD07	REQB_L	52
53	+3.3 V	GNTB_L	54
55	MOT_RSVD	GND	56
57	MOT_RSVD	EREADEY	58
59	GND	NC (RESETOUT_L)	60
61	ACK64#	+3.3 V	62
63	GND	NC (MONARCH#)	64

Table 3-16 shows the J13 pin assignments:

Table 3-16 PMC Connector J13 Pin Assignments

Pin	Signal	Signal	Pin
1	PCI_RSVD	GND	2
3	GND	C/BE7#	4
5	C/BE6#	C/BE5#	6
7	C/BE4#	GND	8
9	VIO	PAR64	10
11	AD63	AD62	12
13	AD61	GND	14
15	GND	AD60	16
17	AD59	AD58	18

Table 3-16 PMC Connector J13 Pin Assignments (continued)

Pin	Signal	Signal	Pin
19	AD57	GND	20
21	VIO	AD56	22
23	AD55	AD54	24
25	AD53	GND	26
27	GND	AD52	28
29	AD51	AD50	30
31	AD49	GND	32
33	GND A	D48	34
35	AD47	AD46	36
37	AD45	GND	38
39	VIO	AD44	40
41	AD43	AD42	42
43	AD41	GND	44
45	GND	AD40	46
47	AD39	AD38	48
49	AD37	GND	50
51	GND	AD36	52
53	AD35	AD34	54
55	AD33	GND	56
57	VIO	AD32	58
59	NC	NC	60
61	NC	GND	62
63	GND	NC	64

The following table shows the J14 pin assignments.

Table 3-17 PMC Connector J14 Pin Assignments

Pin	Signal	Signal	Pin
1	PMCIO1	PMCIO2	2
3	PMCIO3	PMCIO4	4
5	PMCIO5	PMCIO6	6
7	PMCIO7	PMCIO8	8
9	PMCIO9	PMCIO10	10
11	PMCIO11	PMCIO12	12
13	PMCIO13	PMCIO14	14
15	PMCIO15	PMCIO16	16

Table 3-17 PMC Connector J14 Pin Assignments (continued)

Pin	Signal	Signal	Pin
17	PMCIO17	PMCIO18	18
19	PMCIO19	PMCIO20	20
21	PMCIO21	PMCIO22	22
23	PMCIO23	PMCIO24	24
25	PMCIO25	PMCIO26	26
27	PMCIO27	PMCIO28	28
29	PMCIO29	PMCIO30	30
31	PMCIO31	PMCIO32	32
33	PMCIO33	PMCIO34	34
35	PMCIO35	PMCIO36	36
37	PMCIO37	PMCIO38	38
39	PMCIO39	PMCIO40	40
41	PMCIO41	PMCIO42	42
43	PMCIO43	PMCIO44	44
45	PMCIO45	PMCIO46	46
47	PMCIO47	PMCIO48	48
49	PMCIO49	PMCIO50	50
51	PMCIO51	PMCIO52	52
53	PMCIO53	PMCIO54	54
55	PMCIO55	PMCIO56	56
57	PMCIO57	PMCIO58	58
59	PMCIO59	PMCIO60	60
61	PMCIO61	PMCIO62	62
63	PMCIO63	PMCIO64	64

### 3.4.7 Lock Down Flash Enable Jumper

A 0.1 inch, 2-pin header (J17) located on the CPCI-6020 enables lock down of one or more bank A flash. When a jumper is installed between pins 1 and 2, the lock down is enabled.

Table 3-18 J17 Lock Down Flash Enable Jumper

Pin	Signal
1	WP_L
2	GND



### 3.4.8 PMC 66 Mhz Disable Jumper

A 0.1 inch, 2-pin header (J21) located on the CPCI-6020 disables 66 MHz operation on PCI Bus B if jumpered. When a jumper is installed between pins 1 and 2, the PCI Bus B operates at 33MHz, regardless of the PMC's capability. This jumper setting prevents the secondary Ethernet controller from being disabled if a 66 MHz capable PMC is installed. The jumper pulls the M66EN signal low so the PMC knows the bus is running at 33 MHz.

*Table 3-19 J21 PMC 66 MHz Disable Jumper*

Pin	Signal
1	GND
2	M66EN

### 3.4.9 Remote Switch Connector

A 0.1 inch, 3-pin header (J19) located on the CPCI-6020 can be used to extend the front panel's Reset and Abort switches functions through the cables to a remote location.

*Table 3-20 J19 Remote Switch Connector*

Pin	Signal
1	Abort
2	GND
3	Reset

### 3.4.10 Flash Write Protect Enable Jumper

A 0.1 inch, 2-pin header (J20) located on the CPCI-6020 enables write protect of bank A flash. When a jumper is installed between pins 1 and 2, the flash cannot be written.

*Table 3-21 J20 Flash Write Protect Enable Jumper*

Pin	Signal
1	VPP
2	GND

### 3.4.11 Harrier Power Up Configuration

An 8-pin header on the CPCI-6020 provides the means to change some of the Harrier power-up configuration settings. The pin assignments for this header, along with the power-up setting with the shunt on or off, are as follows:

Table 3-22 J22 Harrier Power Up Configuration Header Pin Assignments

Pin	Signal	Signal	Pin	Shunt On	Shunt Off
1	XAD[20] termination	GND	2	PUST0=0	PUST0=1
3	XAD[21] termination	GND	4	PUST1 =0	PUST1 =1
5	XAD[22] termination	GND	6	PUST2=0	PUST2=1
7	XAD[23] termination	GND	8	PUST3 =0	PUST3 =1

### 3.4.12 Xport Flash Bank Select Header

A 0.1 inch, 3-pin header located on the CPCI-6020 controls the state of the Harrier RVEN0 bit during power up and selects which Flash bank functions as the source for the reset vector. Placing the jumper between pins 1 and 2 of J24 selects Xport 0 (Flash Bank A). Placing the jumper between pins 2 and 3 selects Xport 1 (Flash Bank B). The pin assignments for this header are as follows:

Table 3-23 J24 Xport Flash Bank Select Header

Pin	Signal
1	+3.3 V
2	BANKB_SEL_L
3	GND

### 3.4.13 RISCWatch Header

The CPCI-6020 provides a standard 2x8 0.1" header for the RISCWatch interface. The pin assignments for this header are as follows:

Table 3-24 J25 RISCWatch Header Pin Assignments

Pin	Signal	Signal	Pin
1	CPUTDO	No Connect	2
3	CPUTDI	CPUTRST_L	4
5	No Connect	PULLUP	6
7	CPUTCK	No Connect	8

Table 3-24 J25 RISCWatch Header Pin Assignments (continued)

Pin	Signal	Signal	Pin
9	CPUTMS	No Connect	10
11	SRESET_L	No Connect	12
13	CPURST_L	VOID	14
15	CKSTPO_L	GND	16

### 3.4.14 Mictor Debug Connector

A 190-pin Mictor connector provides access to the processor bus (MPU Bus) and some bridge/memory controller signals. It can be used for debugging purposes. The pin assignments are listed in the following table.

Table 3-25 J28 Debug Connector

Pin	Signal		Signal	Pin
1	PA0	GND	PA1	2
3	PA2		PA3	4
5	PA4		PA5	6
7	PA6		PA7	8
9	PA8		PA9	10
11	PA10		PA11	12
13	PA12		PA13	14
15	PA14		PA15	16
17	PA16		PA17	18
19	PA18		PA19	20
21	PA20		PA21	22
23	PA22		PA23	24
25	PA24		PA25	26
27	PA26		PA27	28
29	PA28		PA29	30
31	PA30		PA31	32
33	PAPAR0		PAPAR1	34
35	PAPAR2		PAPAR3	36
37	APE_L	RSRV_L	38	

Table 3-25 J28 Debug Connector (continued)

Pin	Signal		Signal	Pin
39	PD0	+5 V	PD1	40
41	PD2		PD3	42
43	PD4		PD5	44
45	PD6		PD7	46
47	PD8		PD9	48
49	PD10		PD11	50
51	PD12		PD13	52
53	PD14		PD15	54
55	PD16		PD17	56
57	PD18		PD19	58
59	PA20		PD21	60
61	PD22		PD23	62
63	PD24		PD25	64
65	PD26		PD27	66
67	PD28		PD29	68
69	PD30		PD31	70
71	PD32		PD33	72
73	PD34		PD35	74
75	PD36	PD37	76	

Table 3-25 J28 Debug Connector (continued)

Pin	Signal		Signal	Pin
77	PD38	GND	PD39	78
79	PD40		PD41	80
81	PD42		PD43	82
83	PD44		PD45	84
85	PD46		PD47	86
87	PD48		PD49	88
89	PA50		PD51	90
91	PD52		PD53	92
93	PD54		PD55	94
95	PD56		PD57	96
97	PD58		PD59	98
99	PD60		PD61	100
101	PD62		PD63	102
103	PDPAR0		PDPAR1	104
105	PDPAR2		PDPAR3	106
107	PDPAR4		PDPAR5	108
109	PDPAR6		PDPAR7	110
111	Reserved		Reserved	112
113	DPE_L		DBDIS_L	114

Table 3-25 J28 Debug Connector (continued)

Pin	Signal		Signal	Pin
115	TT0	+3.3 V	TSIZ0	116
117	TT1		TSIZ1	118
119	TT2		TSIZ2	120
121	TT3		Reserved	122
123	TT4		Reserved	124
125	CI_L		Reserved	126
127	WT_L		Reserved	128
129	GLOBAL_L		Reserved	130
131	SHARED_L		DBWO_L	132
133	AACK_L		TS_L	134
135	ARTY_L		XATS_L	136
137	DRTY_L		TBST_L	138
139	TA_L		Reserved	140
141	TEA_L		Reserved	142
143	Reserved		DBG_L	144
145	Reserved		DBB_L	146
147	Reserved		ABB_L	148
149	TCLK_OUT		CPUGNT0_L	150
151	Reserved	CPUREQ0_L	152	

Table 3-25 J28 Debug Connector (continued)

Pin	Signal		Signal	Pin
153	CPUREQ1_L		INT0_L	154
155	CPUGNT1_L		MCHK0_L	156
157	WDT1TO_L		SMI_L	158
159	WDT2TO_L		CKSTPI_L	160
161	L2BR_L		CKSTPO_L	162
163	L2BG_L		HALTED	164
165	L2CLAIM_L		TLBISYNC_L	166
167	Reserved		TBEN	168
169	Reserved		Reserved	170
171	Reserved	GND	Reserved	172
173	SRESET_L		Reserved	174
175	HRESET_L		NAPRUN	176
177	SRST1_L		QREQ_L	178
179	SRESET0_D_L		QACK_L	180
181	HRESET_L		CPUTDO	182
183	GND		CPUTDI	184
185	CPUCLK		CPUTCK	186
187	CPUCLK		CPUTMS	188
189	CPUCLK		CPUTRST#	190





## 4.1 Overview

The CPCI-6020 is a CompactPCI system slot controller based on the PowerPlus III architecture and includes support for the Motorola High Availability (HA) architecture (such as the CPX8216). It consists of the MPC7410 processor and L2 backside cache, dual Harrier System Memory Controller /PCI Host Bridge ASICs, 32 MB plus 1 MB of flash memory, and 128 MB to 2 GB of ECC-protected SDRAM on mezzanines. Front panel access is provided for one of the two 10 BaseT/100 Base TX Ethernet channels, an RS-232 serial debug port, two USB ports and the single PMC slot.

The front Ethernet port may also be routed (by means of custom-build option) to the backplane via the CompactPCI J3 and J5 connectors. Other I/O routed to the backplane include a second Ethernet port, two 16550 compatible asynchronous serial ports, two high speed synchronous serial ports, and IDE. A CompactFlash Type I/II compatible socket residing on the IDE Bus is included onboard.

The floppy disk controller, keyboard, and mouse are supported only on the CPCI-6060 5E variants. A parallel port, which was available on the previous generation board, has been eliminated in favor of routing the Ethernet ports to the backplane connectors.

The CPCI-6020 features two host bridges, which allow two totally independent PCI Bus hierarchies. One bus supports the single PMC and the secondary Ethernet port. This bus may be run at 33 MHz or 66 MHz depending on the capability of the installed PMC. When run at 66 MHz, the secondary Ethernet is disabled because it is not 66 MHz capable. The other PCI Bus supports all other onboard PCI resources and runs at a fixed speed of 33 MHz.

The CPCI-6020 board has a 190-pin Mictor connector attached to the processor bus to support board debug. There is also access provided to the MPC7410 processor JTAG port via a standard 16 pin header.

The block diagram for the CPCI-6020 module is shown in [Figure 4-1 on page 82](#).

## 4.2 Block Diagram

The following figure is a block diagram of the CPCPI-6020 architecture.

Figure 4-1 Block Diagram

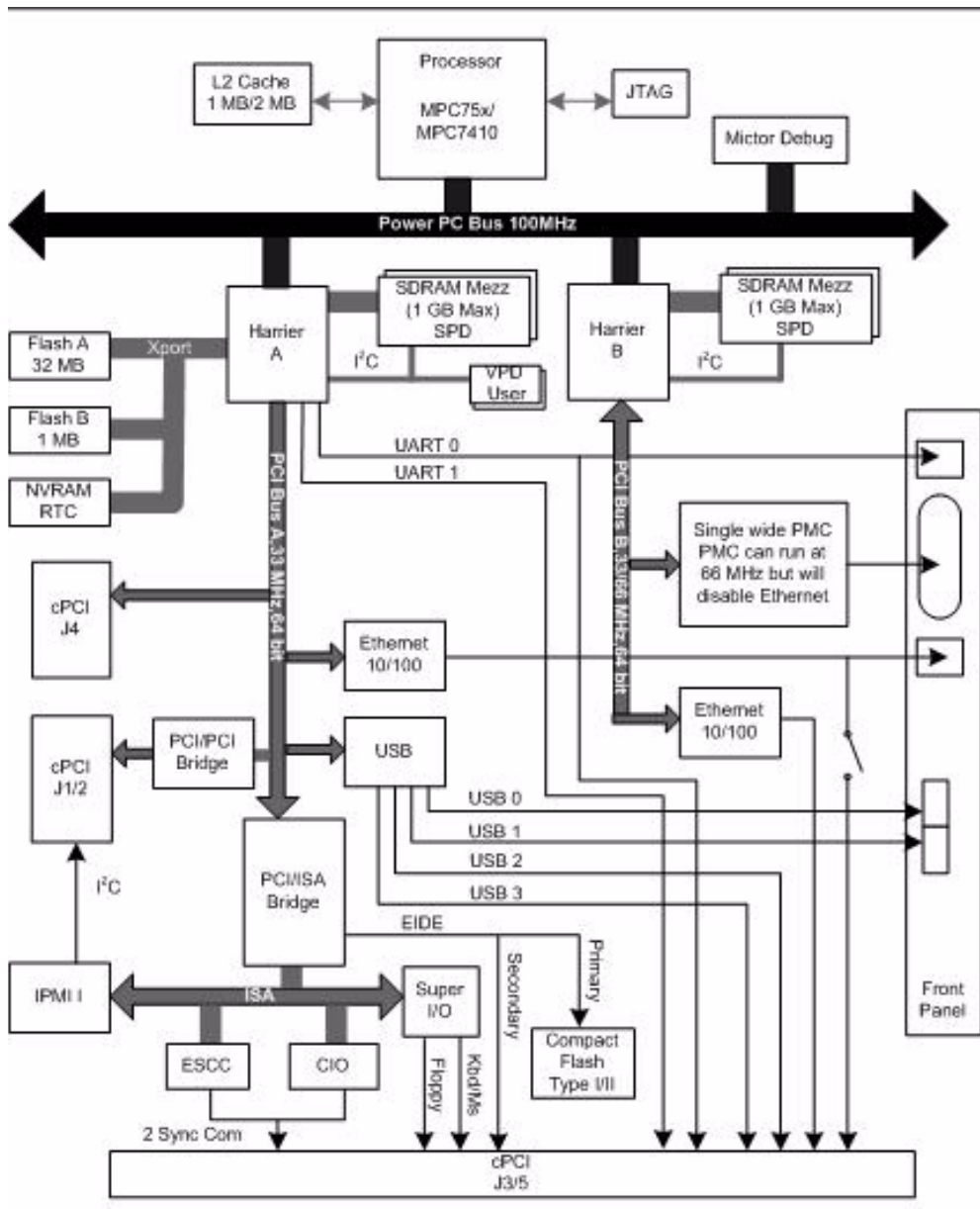

## 4.3 Local PCI Bus Resources

As stated earlier in this chapter, the CPCI-6020 features two host bridges (provided by Harrier A and B ASICs), which allow for two independent PCI Bus hierarchies. The resources of these two buses are described in the following subsections.

### 4.3.1 PCI Bus A Resources

The Harrier A ASIC serves as the bridge from the processor bus (marked PowerPC Bus on the block diagram) to local PCI Bus A. In addition to the Harrier A ASIC, PCI Bus A is connected to two CompactPCI domains: a local domain using a transparent PCI-to-PCI bridge and the J1 and J2 connectors and a remote domain for connection to a Motorola HA chassis using the J4 connector. PCI Bus A also serves as an interface to the primary Ethernet port on the front panel, a PCI/ISA bridge connecting ESCC, CIO, and four USB ports. All features on PCI Bus A are described in the following subsections.

#### 4.3.1.1 Local CompactPCI Bus

PCI Bus A provides a local CompactPCI Bus interface by using the Intel 21154 PCI-to-PCI bridge chip. This device implements a 64-bit primary data bus and 64-bit secondary data bus interface and is PCI 2.1 compliant. The 21154 provides read/write data buffering in both directions.

The 21154 supports +3.3 V or +5 V signalling at the PCI busses with a separate VIO pin for the primary and secondary bus buffers. The primary bus signalling voltage is tied to +5 V. The secondary bus signalling voltage is tied to the CPCI Bus VIO, so the CPCI-6020 is a universal board that may operate in a +3.3 V or +5 V chassis.

A CompactPCI Bus interface will support a maximum of seven CompactPCI cards/loads per segment when operating at 33 MHz. This CompactPCI Bus interface is compliant with the CompactPCI 2.0 specification as listed in [Appendix A, Related Documentation](#).

#### 4.3.1.2 Remote (Expansion) CompactPCI Bus

PCI Bus A is also routed to the J4 connector. In a Motorola HA chassis this is routed across the backplane to a bridge card. On the bridge card this bus interfaces to the remote CompactPCI Bus through a transparent PCI-to-PCI bridge. The interrupts INTA-D# coming from the bridge card are kept separate from the interrupts INTA-INTD# from sources on the CPCI-6020 even though they share the same bus segment.

#### 4.3.1.3 Primary Ethernet Channel

The CPCI-6020 uses an Intel GD82551IT Ethernet Controller to implement a primary 10BaseT/100BaseTx Ethernet channel on PCI Bus A. The GD82551IT consists of both the Media Access Controller (MAC) and the physical layer (PHY) in a single integrated package. The standard board configuration provides for a front panel Ethernet connection via an RJ-45 connector. A custom-build option is available for a rear I/O Ethernet by routing the Ethernet transmit and receive signal pairs to the J5 connector.

This GD82551IT resides on PCI Bus A and always runs at 33 MHz and 64 bits.

The 82551IT interfaces to an AT93C46 serial EEPROM device which provides power up configuration information for the 82551IT. This is a 1 KB device organized as 64 16-bit words. Refer to the corresponding VPD information in [Appendix A, Related Documentation](#) for the contents of this device.

#### 4.3.1.4 ISA Bridge, Including EIDE Function

The CPCI-6020 uses the Winbond W83C554F Peripheral Bus Controller (PBC) device to interface to ISA and EIDE devices, and for additional system resources. The PBC provides the following additional features:

- ISA Bus arbitration for DMA devices
- Functionality of two 82C59 Interrupt Controllers to support 14 ISA interrupts
- Edge/Level control for ISA interrupts
- Steerable PCI interrupts (Note: Feature not used. Interrupt steering is via the Harrier ASIC)
- Seven independently programmable DMA channels (functionality of two 82C37SA devices)
- Three interval Counter/Timer (82C54 functionality)

#### 4.3.1.5 EIDE Interface

The PBC EIDE interface is capable of accelerated PIO transfers, as well as acting as a PCI Bus master on behalf of an IDE DMA slave device. This resource provides a primary and secondary EIDE interface for up to four EIDE devices, and also supports ATAPI-compliant devices.

The primary EIDE interface is routed to the CompactFLASH memory card. The secondary EIDE interface is routed to the J5 User I/O connector for interfacing to external EIDE devices.

Some Motorola HA chassis route the EIDE Bus across the backplane to the peripheral bay. The secondary EIDE interface is implemented in such a way to support these chassis. This includes short traces matched in length, targeted impedance of 80 ohms and onboard termination.

#### 4.3.1.6 ISA Bus Resources

The PBC provides an ISA Bus compatible master and slave interface. The ISA interface supports the following types of cycles:

- PCI master initiated I/O and memory cycles to the ISA Bus
- DMA compatible cycles between main memory and ISA I/O
- ISA master initiated memory cycles to PCI and ISA master initiated I/O cycles to internal PBC registers

#### 4.3.1.7 Synchronous Serial Ports

The two sync/async ports are implemented with the Z85230 ESCC. Since the Z85230 does not have all modem control lines, a Z8536 CIO is used to provide the missing modem lines.

A PLD device is used to perform decode for the Z85230 and the Z8536 for register accesses and pseudo interrupt acknowledge cycles in ISA I/O space. DMA support for the Z85230 is provided by the PBC.

The clock input to the Z85230 PCLK pin is a 10 MHz clock. The two ports will support data transfers up to 2.5 Mbs/sec. The Z85230 supplies an interrupt vector during a pseudo interrupt acknowledge cycle. The vector is modified based upon the interrupt source within the Z85230.

All modem control lines from the ESCC are multiplexed/de-multiplexed through J3 by the P2MX function due to I/O pin limitations.

#### 4.3.1.8 USB Controller

The NEC uPD720101 device provides five USB ports (only four are used) for connectivity with any USB compliant device or hub. It is an USB2.0 host controller, having one EHCI (Enhanced Host Controller Interface) and two OHCI (Open Host Controller Interface) integrated onto a single chip. It is a +3.3 V / +5 V device and supports PCI specification Rev.2.2 (32-bit, 33 MHz). This device supports USB2.0 specification and is also backward compatible with USB1.1 specification. Hi-speed, full-speed or low-speed peripherals are supported along with all of the USB transfer types: control, interrupt, bulk, or isochronous.

Two ports are routed to standard USB Series A receptacle at the front panel. The other two ports are routed to J5 User I/O connector.

The four ports may be independently powered on and off through the use of an external USB power control switch provided on board. Legacy keyboard and mouse interrupts from this device are not supported on the CPCI-6020.

## 4.4 PCI Bus B Resources

The Harrier B ASIC bridges from the processor bus to PCI Bus B. Other than the Harrier, there are only two resources on the bus; the secondary Ethernet controller and a PMC slot. The PMC slot includes secondary arbitration and IDSEL signals as defined in the *VITA 32-199x Processor PMC Standard* which allows for two possible devices on the PMC on this bus segment. PCI Bus B is compliant to PCI Revision 2.1, including 64-bit expansion signals. It runs at +3.3 V levels but is tolerant of +5 V signalling from the PMC. This bus runs at 33 MHz unless a 66 MHz capable PMC is installed in which case the ethernet controller is disabled and the bus runs at 66 MHz.

### 4.4.1 PMC Slot

The CPCI-6020 contains four EIA-E700 AAAB connectors which provide a 32/64-bit PCI interface to an IEEE P1386.1 compliant PMC. Connectors J11-J13 provide the 32/64-bit PCI interface while J14 provides a user I/O path from the PMC slot to the CompactPCI backplane. PMC user I/O signals are routed from the PMC J14 connector to the CompactPCI J3 connector following the PIM differential signalling recommendations. A cutout in the CPCI-6020 allows for front I/O through the PMC face plate.

If a 66 MHz capable PMC is installed, which is indicated by the state of its M66EN pin, PCI Bus B is also configured at power up to run at 66 MHz. In this case, the 82551IT Ethernet device on this bus, which is not 66 MHz capable, is disabled. If no PMC is installed, or if the PMC is not 66 MHz capable, then the bus runs at 33 MHz and the Ethernet device remains enabled. A jumper is provided to override the M66EN pin from the PMC and force the bus to run at 33 MHz.

The Harrier PCI I/O buffers operate at +3.3 V output levels and are +5 V tolerant allowing the PCI interface to operate at either voltage level. VIO is connected to +3.3 V on the planned standard product, but may be connected to +5 V by means of a build option. If VIO is connected to +5 V then 66 MHz PCI operation is prohibited and disabled by means of a build option.

The following special function processor PMC pins, as defined by the Processor PMC Standard VITA 32-2003, are implemented on the CPCI-6020 as described in the following table:

Table 4-1 Special Function Processor PMC Pins

PrPMC Signal	Pin Number	Support
PRESENT#	J11-7	The PRESENT# signal from the slot is used in conjunction with M66EN to detect the presence of a 66 MHz capable PMC. The state of this bit is readable in the external register set on Harrier A Xport channel 2.
MONARCH#	J12-64	The CPCI-6020 leaves the MONARCH# pin floating, causing any installed processor PMC to operate as a slave module. Processor PMC monarch mode is not supported.
IDSELB	J12-34	IDSELB is connected to PCI Bus B AD[17].
REQB#	J12-52	REQB# is routed to the PCI Bus B arbiter.
GNTB#	J12-54	GNTB# is routed to the PCI Bus B arbiter.
M66EN	J12-47	The CPCI-6020 has a weak pull-up on this signal. If the signal is grounded, as it will be on 33 MHz PMCs, the PCI Bus B will be configured to run at 33 MHz upon power-up. If this line is left floating, as it will be on 66 MHz capable PMCs, and it is qualified by assertion of PRESENT#, then PCI Bus B will be configured to run at 66 MHz upon power-up (as a side effect the secondary ethernet controller on PCI Bus B will be disabled). A jumper is provided on the CPCI-6020 to ground and thereby defeat the 66 MHz enable signal.
RESETOUT_L	J12-60	The CPCI-6020 does not make any connection to RESETOUT_L.
EREDY	J12-58	The EREADY signal (driven by the PMC) is connected to the Harrier B EREADY pin and may be read in the XCSR.MCSR.EREDY register of Harrier B. A pull-up is provided on board.

## 4.4.2 Secondary Ethernet Channel

The CPCI-6020 uses the Intel GD82551IT Ethernet controller to implement a secondary 10BaseT/100 BaseTx Ethernet channel on PCI Bus B. The GD82551IT consists of both the Media Access Controller (MAC) and the physical layer (PHY) in a single integrated package. The secondary Ethernet provides only rear I/O by routing the Ethernet transmit and receive signal pairs to J5 connector.

The GD82551IT82551IT is limited to a maximum of 33 MHz PCI Bus operation. If the PMC slot is populated with a 66 MHz capable PMC, the PCI Bus B will run at 66 MHz and this Ethernet controller will be disabled by keeping it in reset.

The 82551IT interfaces to an AT93C46 serial EEPROM device which provides power up configuration information for the 82551IT. This is a 1 kilobit device organized as 64, 16-bit words.

## 4.5 Processor Bus Resources

Devices resident on the processor bus of the CPCI-6020 are a single processor, two Harriers (denoted Harrier A and Harrier B) and a Mictor debug connector. The bus is the standard 60x interface running at 100 MHz. Processor address and data bus parity generation and checking is supported in conjunction with the Harrier ASICs. The MPX Bus extension, which the MCP7410 is capable of, is not supported.

The MCP7410 processor uses a +2.5 V signalling level and is not +3.3 V tolerant. Care should be taken that probe boards attached to the Mictor debug connector do not pull up or drive signals in violation of this. The JTAG port is tolerant of +3.3 V signals.

### 4.5.1 Processor

The CPCI-6020 has the 360-pin CBGA foot print that supports the MPC7410 family of processors. The CPCI-6020 supports an external processor bus speed of 100 MHz. The common processor configuration will support variable core voltages between 0.8V and +3.3 V and I/O voltages of either +2.5 V or +3.3 V.

### 4.5.2 L2 Cache

The CPCI-6020 uses a back-side L2 cache structure via the MPC7410 processor chip families. The L2 cache is implemented with an on-chip, 2-way set-associative tag memory and external direct-mapped synchronous SRAMs for data storage. The external SRAMs are accessed through a dedicated 72-bit wide (64 bits of data and 8 bits of parity) L2 cache port. The MPC7410 processor can support up to 2 MB. The L2 cache can operate in copyback or write-through modes and supports system cache coherency through snooping. Data parity generation and checking can be disabled by programming the processor L2 cache control registers accordingly. The MPC7410 processor also supports direct mapping of the SRAM memory, in conjunction with normal L2 cache operation. In this mode, a portion of the SRAM memory space may be mapped to appear as a private memory space in the memory map. Refer to the processor data sheet for additional information.

The L2 cache data SRAM for the CPCI-6020 is implemented using two 128 KB x 36-bit or 256 KB x 36-bit synchronous pipelined burst SRAMs providing a total 2 MB of L2 cache. Either memory size is able to support a minimum L2 bus speed of 200 MHz. The common SRAM footprint supports only +3.3 V core voltages and either +2.5 V or +3.3 V I/O voltages.

## 4.6 Harrier System Memory Controller and PCI Host Bridge ASIC

The Harrier ASIC provides the bridge function between the PPC60X Bus, the system memory and the PCI Local Bus. The Harrier ASIC provides the following key features:

- 100 MHz PowerPC Bus interface
- SDRAM interface supporting up to eight banks of 256 MB each, with ECC
- 32/64-bit Rev 2.1 compliant PCI Bus interface capable of running up to 66 MHz

- Single channel DMA controller
- Message passing unit supporting I2O and generic functions
- Two internal 16550-type UARTs
- Two I<sup>2</sup>C Bus master interfaces
- MPIC compliant interrupt controller
- Four Xport channels for interfacing to flash or other external registers/devices

Refer to the *Harrier Application Specific Integrated Circuit (ASIC) Programmer's Reference Guide* (ASICHRA1/PG) for additional information and programming details.

## 4.6.1 Dual Harrier Assignments

The CPC1-6020 employs dual Harrier ASICs identified as Harrier A and Harrier B. Harrier A is used for access to part of system memory, access to all of flash memory, NVRAM, RTC, external registers, UARTs, onboard I<sup>2</sup>C, bridging to PCI Bus A and for top level control of all interrupts. Harrier B is used for access to part of system memory, bridging to PCI Bus B and for controlling some interrupts.

## 4.6.2 Harrier Power-Up Configuration

The Harrier ASIC XAD30-XAD0 pins provide configuration information for Harrier at power-up reset time. The following table lists the default power-up reset state of these pins for the CPC1-6020. The Select Option column indicates whether the power up setting can be changed by build option resistor or by jumper, or if the setting is fixed and cannot be changed. The default power-up setting column indicates the default values of the standard CPC1-6020 product. Default settings for jumper options indicate power up value with jumper not installed.

Table 4-2 Harrier Power-Up Configuration Settings

Harrier XAD Bus Signal	Select Option	Power Up Default	Register Bit(s)	Meaning of Power-Up Default State
XAD[30]	Resistor	0	XCSR.XPGC.HDM	Xports not Hawk Data Mode compatible.
XAD[29]	Fixed	0	XCSR.UCTL.UCOS	Select external clock source for UART.
XAD[28]	Resistor	0	XCSR.BPCS.CSH	Other PCI masters may access Harrier configuration space.
XAD[27]	Resistor	0	XCSR.BPCS.CSM	All of Harrier's PCI configuration registers are visible from PCI space.
XAD[26]	Resistor	0	XCSR.BXCS.P0HO /P1HO	Disable processor hold off at power up.
XAD[25]	Fixed	1	XCSR.SDTC.SDER	There are external buffers in series with the BAx, RAx, WE, RAS or CAS signals.
XAD[24]	Resistor	A = 1 B = 0	XCSR.GCSR.AOA O	Harrier A will respond to unmapped address only cycles, Harrier B will not.



Table 4-2 Harrier Power-Up Configuration Settings (continued)

Harrier XAD Bus Signal	Select Option	Power Up Default	Register Bit(s)	Meaning of Power-Up Default State
XAD [23:20]	Jumpers	1111	XCSR.GCSR.PUST [3:0]	Generic Power Up Status Bits (Software readable header)
XAD[19]	Resistor	0	State of bit can be inferred: XCSR.CLAS (XCSR+\$308)	Set PCI Configuration register CLAS to present class code for "bridge device".
XAD[18]	Resistor	1	XCSR.PARB.ENA	Enable internal PCI arbiter
XAD[17]	Fixed	A=1 B=0	XCSR.XARB.ENA	Harrier A, enable internal PPC arbiter Harrier B, disable internal PPC arbiter
XAD [16:15]	Fixed	A=00 B=01	XCSR Register Group Base Address	Harrier A XCSR base addr. \$FEFF0000 Harrier B XCSR base addr. \$FEFF1000
XAD [14-12]	On board logic sets ratio	000	XCSR.GCSR.RAT	Reserved
		001		PPC-to-PCI clock ratio 3:2
		010		PPC-to-PCI clock ratio 2:1
		011		PPC-to-PCI clock ratio 5:2
		100		PPC-to-PCI clock ratio 1:1
		101		Reserved
		110		PPC-to-PCI clock ratio 3:1
		111		Reserved
XAD [11:10]	Fixed	A=01 B=XX	XCSR.XPAT0.DW	Harrier A, Flash Bank A 16-bits wide Harrier B, Flash Bank A not used.
XAD[9]	Jumper on board	A=1 B=0	XCSR.XPAT0.RVEN	Harrier A, Flash Bank A is Reset Vector. Harrier B has no flash.
XAD [8:7]	Resistor	A=01 B=xx	XCSR.XPAT1.DW	Harrier A, Flash Bank B to 16-bit width Harrier B, Flash Bank B not used.
XAD[6]	Fixed	A=1 B=0	XCSR.XPAT1.RVEN	Harrier A, Flash Bank B is Reset Vector if and only if Bank A is not Reset Vector. Harrier B has no flash.
XAD [5:4]	Fixed	A=00 B=xx	XCSR.XPAT2.DW	Harrier A, Xport Ch. 2 8-bit width. Harrier B, Xport Ch. 2 not used.
XAD[3]	Fixed	0	XCSR.XPAT2.RVEN	Disable Xport channel 2 as Reset Vector
XAD [2:1]	Fixed	xx	XCSR.XPAT2.DW	Xport Channel 3 Data Width Unused.
XAD[0]	Fixed	0	XCSR.XPAT3.RVEN	Disable Xport channel 3 as Reset Vector



Except where noted, Harrier A and Harrier B have the same default power-up setting.

### 4.6.3 Debug Connector

One 190-pin Mictor connector with center row of power and ground pins is used to provide access to the processor bus and some miscellaneous signals. When the CPCI-6020 is populated with an MPC7410 processor this bus is not tolerant of +3.3 V or +5 V signals. Boards attached to this connector should not drive or pull signals up to intolerable levels.

### 4.6.4 PPC Bus Arbitration

The Harrier ASIC contains arbiters for the PPC Bus and the PCI Bus. The Harrier A PPC arbiter is used to arbitrate between the processor, the Harrier A and the Harrier B PPC Bus masters for ownership of the PPC Bus. The processor is connected to the Harrier A arbiter CPU0\_REQ/CPU0\_GNT signal pair (XARB3/XARB0) and Harrier B is connected to the Harrier A arbiter EXTL\_REQ/EXTL\_GNT signal pair (XARB5/XARB2). For more information on PPC Bus arbitration refer to the *CPCI-6020 CompactPCI Single Board Computer Programmer's Reference Guide* and the *Harrier Application Specific Integrated Circuit (ASIC) Programmer's Reference Guide*.

## 4.7 ECC Memory Bus Resources

The CPCI-6020 supports 2 GB of memory via four RAM500 mezzanine modules populated in the two memory connectors J7 and J28. There is no onboard memory. The ECC protected memory mezzanines are distributed as separate sets, one attached to each Harrier. The CPCI-6020 supports a total of 1 GB using currently available 256 MB SDRAMs, (evenly divided between the two Harriers) and supports 2 GB when 512 MB SDRAMs become available.

### 4.7.1 Harrier A Memory Bus

Harrier A memory bus is routed to a connector on which a RAM500 mezzanine may be mounted. The RAM500 mezzanine is capable of stacking so a total of two mezzanines may be attached to the Harrier A memory bus. The mezzanines appear as Banks C and E to the Harrier. Each mezzanine has a storage capacity of 256 MB of ECC protected memory using available 256 megabit SDRAMs, and a capacity of 512 MB when 512 megabit SDRAMs are available.

The I<sup>2</sup>C SPD serial ROMs on these mezzanines are connected to Harrier A's I<sup>2</sup>C port 0.

## 4.7.2 Harrier B Memory Bus

Harrier B memory bus is also routed to a RAM500 compatible connector and has capabilities and characteristics identical to the Harrier A memory bus. The ECC protected memory banks on this memory bus appear as Banks C and E to Harrier B.

## 4.7.3 RAM500 Memory Mezzanine

Each RAM500 mezzanine carries nine SDRAM parts in a x8 configuration, a buffer for certain control signals and a single +3.3 V, 256 x 8, SPD serial ROM. Each lower RAM500 attached to the host board has its SPD addressable at \$AA from the Harrier to which it is attached, the upper at \$AC.

The following are the expansion mezzanine size options for a single board. Boards of any size can be stacked.

Table 4-3 Expansion SDRAM Memory Mezzanine Size Options

SDRAM Memory Size (Banks)	Device Size	Device Organization (depth x width-in-bits)	Number of Banks	Number of Devices
32 MB	64 megabit	4 MB X 16	1	5
64 MB	64 megabit	8 MB X 8	1	9
128 MB	128 megabit	16 MB X 8	1	9
256 MB	256 megabit	32 MB X 8	1	9
512 MB	512 megabit	64 MB X 8	1	9

## 4.8 Harrier Xport Resources

The Xport is a bridge that interfaces the 60x bus to an expansion bus named Xport Bus. Each of the two Harriers on CPCI-6020 has a separate Xport Bus. The Xport Bus is the set of signals Harrier uses to control devices that have a simple, static RAM style interface. Such devices include flash, NVRAM, RTC and external registers. A 60x bus slave and an Xport Bus master constitute the most significant blocks that make up Xport within Harrier. The 60x bus slave has four address response ranges. The Xport Bus master has four corresponding chip selects. An address range with its corresponding chip select is referred to as a channel (0 through 3). Each channel employs a combination of control registers and input signal pins to configure its address range and attributes. Refer to the *Harrier Engineering Specification* for additional details.

## 4.8.1 Harrier A, Channel 0 - Onboard Bank A Flash

The CPCI-6020 contains one bank of flash memory soldered onboard. Bank A consists of a single Intel Strata Flash P30 16-bit flash, providing 32 MB of memory. The following table defines the flash type and size. The device support spage-read mode operations with an 4-word page size. Flash Bank A is not ECC protected.

Table 4-4 Bank A Flash Options

Bank A Flash Size	Intel Part	Device Size	Device Width
32 MB	1.8 Volt StrataFlash Memory	256 megabit	16 bits

## 4.8.2 Harrier A, Channel 1 - Socketed Bank B Flash

The CPCI-6020 contains two 32-pin PLCC sockets connected to Harrier A Xport channel 1, which can be populated with 1 MB of flash memory using AMD AM29LV040B or equivalent devices. This flash memory appears as flash Bank B to the Harrier A chip. Xport channel 1 is configured to operate in normal address and data mode where the data alternates every byte instead of every fourth byte (Hawk data mode). Only 8-bit writes are supported for this bank.

The reset vector may be sourced by either Bank A or Bank B depending on the state of Harrier Xport 0 reset vector control bit RVEN0. When the RVEN0 bit is cleared, address range FFF00000-FFFFFFFF maps to Bank B. When RVEN0 bit is set, it maps to Bank A. The default state uses Bank A for the reset vector. Bank B may be selected by connecting the BANKB\_SEL\_L pin to GND. Flash Bank B is not ECC protected.

## 4.8.3 Harrier A, Channel 2 - NVRAM, RTC, External Register Set

The Harrier A Xport 2 interface consists of the STMicroelectronics M48T37V. This device provides 32 KB of nonvolatile static RAM, a real-time clock and a watchdog function. Refer to the M48T37V Data Sheets for programming information. The M48T37V consists of two parts:

- A 44-pin 330mil SO device which contains the RTC, the oscillator, the power fail detection, the watchdog timer logic, 32 KB of SRAM and gold-plated sockets for the SNAPHAT battery.
- A SNAPHAT that houses the battery and/or the crystal

The output of the watchdog timer is logically **ORed** onboard to provide a hard reset. This signal is routed to PLD ORing logic so that this feature may be disabled. Xport 2 is configured to operate in Harrier 8-bit data mode.

## 4.8.4 Harrier A, Channel 3

The Xport interface is not used.

## 4.8.5 Harrier B, Channel 0, 1, 2 and 3

None of the Harrier B Xport Channels are used.

## 4.9 Other Harrier Resources

The following subsections discuss other resources that are available through the Harrier ASIC.

### 4.9.1 I<sup>2</sup>C Bus Resources - Serial EEPROM

The CPCI-6020 contains two 8 KB Serial EEPROM devices onboard and provisions for four 256-byte Serial EEPROM devices on memory mezzanines.

- One 8 KB Serial EEPROM provides for Vital Product Data (VPD) storage of the module hardware configuration
- One 8 KB device for storage of user configuration data.

The contents of the 8 KB devices are accessed by providing a two-byte address with the same device ID, instead of the standard one-byte address as used in the 256-byte devices. The 256-byte devices provide for Serial Presence Detect (SPD) memory configuration information. The Serial EEPROMs for VPD, user data and memory attached to Harrier A are accessed through I<sup>2</sup>C port 0 in the Harrier A ASIC.

The Serial EEPROM's for memory attached to Harrier B are accessed through I<sup>2</sup>C port 0 in the Harrier B ASIC. Refer to the *CPCI-6020 CompactPCI Single Board Computer Programmer's Reference Guide* for SROM device address assignments.

### 4.9.2 Asynchronous Serial Ports

The CPCI-6020 provides two asynchronous serial interfaces. UART0 and UART1 in the Harrier A provide the 16550 compatible UART controllers. The UART0 port signals are wired to an RS-232 transceiver which interfaces to the front panel RJ-45 connector. The UART0 port may optionally be wired to the backplane via J5 instead. The UART1 port is wired to the J5 connector only. An onboard 1.8432 MHz oscillator provides the baud rate clock for the UARTs. Refer to the *Harrier Application Specific Integrated Circuit Programmer's Reference Guide* for additional UART information.

### 4.9.3 32-Bit Timers

Four 32-bit timers are provided by each Harrier (MPIC) that may be used for system timing or to generate periodic interrupts. Each timer is driven by a divide-by-eight prescaler which is synchronized to the PPC processor clock. For a 100 MHz processor bus, the timer frequency would be 12.5 MHz. Refer to the Harrier Engineering Specification for additional information and programming details on these timers.

### 4.9.4 Watchdog Timers

Both Harrier ASICs contain two Watchdog Timers, WDT1 and WDT2. Each timer is functionally equivalent but independent. These timers will continuously decrement until they reach a count of 0 or are reloaded by software. The time-out period is programmable from 1 microsecond up to 32 minutes. If the timer count reaches 0, a timer output signal will be

asserted. The output of Harrier A Watchdog Timer 1 is routed to a Harrier A MPIC interrupt. The output of Harrier A Watchdog Timer 2 may be optionally routed by means of a build option to a Harrier A MPIC interrupt or to provide a board hard reset. The standard CPCI-6020 product will be built to provide hard reset.

The output of Harrier B Watchdog Timer 1 and 2 are routed to a Harrier B MPIC interrupt.

Following a Harrier device reset, WDT1 is enabled with a default time-out of 8 seconds and WDT 2 is enabled with a default time-out of 16 seconds. Each timer must be disabled or reloaded by software to prevent a time-out. Software may reload a new timer value or force the timer to reload a previously loaded value. To disable or load/reload a timer requires a two step process. Refer to the Harrier specification for additional timer details

## 4.10 Other Board Resources

The following subsections describe other resources that are available on the CPCI-6020.

### 4.10.1 Miscellaneous Control and Status

The Harrier ASIC contains a Miscellaneous Control and Status register that provides the CPCI-6020 with the board fail LED control, PrPMC EREADY pin status, board reset control, and processor timebase enable control. Refer to the *Harrier Application Specific Integrated Circuit (ASIC) Programmer's Reference Guide* for additional details.

### 4.10.2 Clock Generator

The CPCI-6020 clock generator uses an MPC9772 PLL clock driver in conjunction with an MPC93R52 zero delay buffer to provide the clocks for the processor, both Harrier ASICs, the SDRAMs and all PCI devices. The PPC-to-PCI clock ratios which are support by the CPCI-6020 are shown in the table below. The PCI Bus A runs at a fixed speed of 33 MHz. On board logic uses the state of the PMC M66EN pin to determine if the PCI Bus B clock frequency will be 33 MHz or 66 MHz. The maximum PPC Bus frequency (66 MHz or 100 MHz) is determined at board assembly time by populating the appropriate select resistors. The 100 MHz bus mode will be the standard configuration.

Table 4-5 PPC to PCI Clock Ratios

PPC Clock Frequency (MHz)	PCI Clock Frequency (MHz)	Ratio (PPC:PCI)	Harrier PCI Clock Divisor (N)
100	33.33	3:1	12
	66.67	3:2	6
66.67	33.33	2:1	8
	66.67	1:1	4

### 4.10.3 Onboard Power Supplies

The CPCI-6020 requires +5 V, +3.3 V, +1.8 V and +/-12 V (optional) input voltages. The processor core voltage and +2.5 V for the Harrier core are generated on board from the +5 V input by switching regulators. The processor core voltage regulator has a variable output which is set using feedback resistors. In addition to the Harrier core voltage, the +2.5 V supply will provide the processor, Harriers and L2 cache I/O voltage when the MPC7410 processor is used. Power resistors installed during assembly will select either +3.3 V or +2.5 V to supply the I/O voltage for the processor, Harriers and the L2 cache. +1.8 V is generated using an onboard regulator through +3.3 V.

### 4.10.4 Board Reset Logic

A block diagram of the CPCI-6020 board reset logic is shown below. The board reset logic is implemented in a programmable logic device (PLD) in order to provide maximum flexibility of the circuit design.

There are several potential sources of reset on the CPCI-6020. They are:

- Power-on/under voltage reset
- Front panel reset switch
- CompactPCI PRST#
- Watchdog Timer reset via Harrier A WDT2
- CompactPCI FAL# signal
- Software generated hard reset via the Harrier RSTOUT bit
- Software generated hard reset via the Port 92 Register in the PBC
- CompactPCI Bus reset via the 21154 Bridge Control Register
- Processor RISCWatch JTAG emulator interface HRESET# signal (open collector)

There is an optional build configuration for reset from the RISCWatch JTAG interface. In Option 2, the RISCWatch CPURST\_L will reset the Harrier ASIC in addition to the processor. This option may be used in cases where the state of the Harrier logic must be guaranteed when a RISCWatch CPURST\_L is issued. However, implementing this option will prevent the use of the RISCWatch probe **Reset and Run from RAM** mode since the Harrier SDRAM configuration settings will be lost when the reset occurs. The Option 2 connection will not be implemented in the standard board configuration.

Figure 4-2 Reset Block Diagram

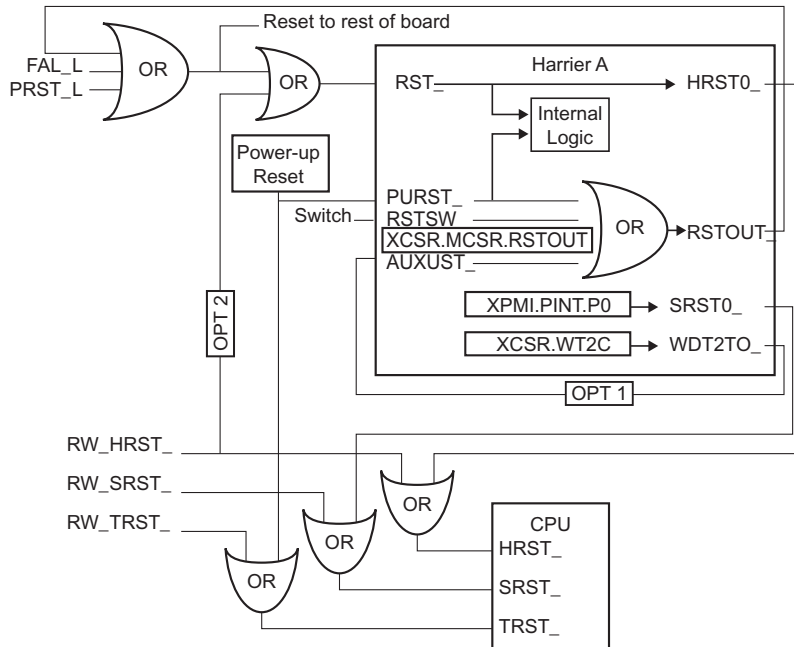

The RST\_ and PURST\_ inputs of Harrier B are tied to those of Harrier A, respectively. The AUXRST\_ and RSTSW\_ inputs of Harrier B are held inactive. The RSTOUT\_, HRST0\_ and SRST0\_ outputs of Harrier B are not connected. The watchdog timers of Harrier B do not generate reset.

The following table shows which devices are affected by various reset sources:

Table 4-6 Reset Sources and Devices Affected

Device Affected	Processor	Harrier ASIC	PCI Devices	ISA Devices	Local CompactPCI Bus
Software Hard Reset (Harrier RSTOUT, PBC Port 92)	•	•	•	•	•
Software Hard Reset (Harrier RSTOUT, PBC Port 92)	•	•	•	•	•



Table 4-6 Reset Sources and Devices Affected (continued)

Device Affected	Processor	Harrier ASIC	PCI Devices	ISA Devices	Local CompactPCI Bus
Software Hard Reset (Harrier RSTOUT, PBC Port 92)	•	•	•	•	•
Software Hard Reset (Harrier RSTOUT, PBC Port 92)	•	•	•	•	•
Software Hard Reset (Harrier RSTOUT, PBC Port 92)	•	•	•	•	•
Software Hard Reset (Harrier RSTOUT, PBC Port 92)	•	•	•	•	•
CompactPCI Reset (21154 Bridge Control Register)					•
Processor RISCWatch JTAG HRESET# Signal	•	(.) <sup>1</sup>			

1. Available as a build option (not enabled in standard configuration).

### 4.10.5 Soft Reset

Software can assert the SRESET# pin of the processor by programming the P0 bit in the Processor Init Register of the Harrier MPIC appropriately.

### 4.10.6 Front Panel Resources

The CPCI-6020 front panel provides access to recessed Abort and Reset push-button switches, Board Fail, CPU Bus Activity and Hot Swap Status LEDs, an RJ-45 Ethernet connector, an RJ-45 serial port connector, two USB connectors and the PMC front panel.

### 4.10.7 ABORT# and RESET# Switches

Two push-button switches provide ABORT# and RESET# inputs to the CPCI-6020. Both switches are recessed to reduce the likelihood of accidental activation. The ABORT# signal is connected to the Harrier Abort Switch (ABTSW\_L) input and generates an MPIC internal interrupt. The RESET# signal is connected to the Harrier Reset Switch (RSTSW\_L) input which will generate a Harrier Reset Out, which is ORed with the board reset logic. Each signal is debounced in the Harrier ASIC.

### 4.10.8 On-Board LEDs

The CPCI-6020 provides two LEDs visible on the front panel for status of CPU and Board Fail (BDFL).

- The green CPU LED is lit when the DBB# signal of processor bus is active (hardware controlled).
- The yellow FAIL LED is lit when the Harrier BDFL bit in the Miscellaneous Control and Status register is active (software controlled).

Refer to the *Harrier Application Specific Integrated Circuit (ASIC) Programmer's Reference Guide* for details of the BDFL bit.

### 4.10.9 Harrier Power Up Configuration Header

An 8-pin header provides the means to change some of the Harrier power up configuration settings. Refer to [Chapter 3, Controls, LEDs, and Connectors](#) for configuration settings controlled by this header. A shunt must be installed to change a setting. The default configuration setting (with the shunt not installed) is also given in that chapter.

## 4.11 Hot Swap Support

The CPCI-6020 provides hardware to support the physical connection process and the hardware connection process of the full hot swap system model defined in the *CompactPCI Hot Swap Specification*. This hardware supports the hot swap of peripheral boards in standardized (non-high availability) chassis. Hot swapping of the CPCI-6020, the system controller, itself is not defined in the CompactPCI specifications. A description of CPCI-6020 support for system slot hot swapping is in the following high availability support section.

## 4.12 High Availability Support

The CPCI-6020 includes support for system slot hot swap in Motorola's chassis. This includes high availability (HA) features defined in the CompactPCI Hot Swap Specification as well as Motorola's added extensions.

Standardized features include implementation of the BD\_SEL#, HEALTHY# and PCI\_RST# signals. Motorola extensions are described in the following sections.

### 4.12.1 HSC Bridge Board Interface

The CPCI-6020 interfaces with a local bridge card which resides on the remote CompactPCI Bus. The bridge card is named local because it bridges down, in a hierarchical sense, from this CPCI-6020 local domain to the remote bus. Similarly there is a remote CPU card with a remote bridge card which bridges down to, and resides on, this local CompactPCI Bus.

The PCI Bus routed to the J4 connector provides the communication path to the local bridge card. There are also four signals in the J3 connector which comprise the communication with the remote bridge card. When the CPCI-6020 is in control of the local CompactPCI Bus, these signals allow the HSC on the remote bridge card to force the CPCI-6020 to quiesce the local CompactPCI Bus and tri-state its 21154. This allows that HSC to then activate its own 21154 and assume control of the local CompactPCI Bus.

## 4.12.2 Local CompactPCI Bus Interface

Backplane communication is accomplished through the Intel 21154 transparent PCI-to-PCI bridge. This device is not intended to support hot swap circuitry which has been added to the CPCI-6020 to adapt the 21154 to this purpose and is described in the following sections.

## 4.12.3 Secondary Bus Arbitration

The 21154 internal secondary bus arbiter is not used on the CPCI-6020 because special HA features are required. An external arbiter is used instead.

The external arbiter includes an interface to the Hot Swap Controller (HSC) located on the remote bridge board. Through this interface the HSC may cause the arbiter to refuse to grant the local CompactPCI Bus to any of the peripheral slot boards. In this manner the bus may be made quiescent in preparation for a transfer of control from the CPCI-6020 to the bridge board that bridges the remote domain down to the local CompactPCI Bus.

## 4.12.4 Secondary Bus Tri-Stating

When the CPCI-6020 is taken offline by the bridge board from the remote domain, its 21154 must be disabled to prevent it from responding to backplane transactions. The 21154 is designed to drive its secondary bus signals to an inactive state when in reset. This would prevent the remote bridge from assuming control of this bus. To overcome this there is a device on the CPCI-6020 which can use the JTAG interface on the 21154 to put it into a high impedance mode. That device is controlled by the remote bridge card.

## 4.12.5 System Slot Hot Swap

The CPCI-6020 may be safely inserted and extracted from the system chassis while power is applied. Hot swap circuitry protects the board from electrical damage.

In systems that support high availability, the CompactPCI Bus may be active while the CPCI-6020 is inserted and/or removed without disturbing the bus traffic. This is accomplished by pin-staged CompactPCI Bus connections, a switched pre-charged voltage level applied to bussed pins and tri-stating of PCI-to-PCI bridge signals during insertion and removal.

The BD\_SEL# signal from CompactPCI Bus J1 pin D15 must be driven true (low) for the back end power supplies to switch on. When BD\_SEL# is not asserted only a small portion of the CPCI-6020 circuitry is powered.

The HLTY# signal is driven true (low) to the CompactPCI bus J1 pin B4 when the +5.0VDC, +3.3VDC, +12VDC, and -12VDC and the J18 jumper is not installed. When the J18 jumper is installed, only +5.0VDC and +3.3VDC are included in the HLTY# status and input power supplies are all within tolerance. This can be used as a status indicator.

## 4.13 EIDE Interface

The CPCI-6020 supports primary EIDE onboard and the secondary EIDE channel which is routed to the J5 User I/O connector. The CPCI-6020-MCPTM-01 contains the secondary EIDE interface which supports a removable external EIDE device. The header of this EIDE is not accessible through the rear panel. A cable must be used to connect an external EIDE device to the header.

## 4.14 Ethernet Interface

The CPCI-6020 provides two 10BaseT/100BaseTX autoselect Ethernet interfaces. The first Ethernet interface is routed to a RJ-45 connector located at the front panel of the board and also to the J5 connector for Ethernet connection on the CPCI-6020-MCPTM-01. The transition board option is selectable through option resistors during CPCI-6020 board assembly time. The standard board route is to the front panel only. Contact your sales representative for more information on the transition board option). The second Ethernet interface is routed only to the J5 connector for Ethernet connection on the CPCI-6020-MCPTM-01.

The Ethernet Station Addresses are determined by the CPCI-6020 and are not affected by the CPCI-6020-MCPTM-01.

## 4.15 Hot Swap Support

The CPCI-6020-MCPTM-01 is considered to be part of the CPCI-6020. Therefore, the CPCI-6020-MCPTM-01 cannot be swapped without first removing or powering down the CPCI-6020. All power for the CPCI-6020-MCPTM-01 is provided from the CPCI-6020 through pins on the J3/J5 I/O connectors.

## 4.16 PMC Interface Module (PIM)

A single PMC Interface Module (PIM) site is supported on the CPCI-6020-MCPTM-01 in line with the PMC module supported on the CPCI-6020. The CPCI-6020 provides two 64-pin EIA-E700 AAAB connectors to interface to a 32/64-bit IEEE P1386.1 PMC. One of the two connectors is dedicated to user I/O. The CPCI-6020 maps the PMC user I/O pins onto the CompactPCI J3 and J5 connectors. The CPCI-6020-MCPTM-01 reverses the mapping and brings the signals to a 64-pin EIA-E700 AAAB connector to interface with its PIM site. This causes a one-to-one correspondence in the pinout between the PMC on the CPCI-6020 and the PIM site on the CPCI-6020-MCPTM-01. Refer to the section titled [PMC Slot on page 85](#) in this chapter for a detailed description of the CPCI-6020's PMC site.

## 4.17 Asynchronous Serial Ports

The CPCI-6020 provides two 16550 compatible asynchronous serial interfaces, COM1 and COM2. The COM1 port signals are wired to the front panel RJ-45 connector and it may optionally be wired to the backplane via J5 instead. The COM2 port is wired to the J5 connector only.

COM1 is routed to an RJ-45 connector located at the rear panel of the CPCI-6020-MCPTM-01. COM2 can be accessed by a planar 9-pin header on transition module. The COM2 signals are also wired to PMC I/O connector for possible access through PMC I/O module.

## 4.18 Synchronous Serial Ports

The two synchronous ports, COM3 and COM4, are implemented with the Z85230 ESCC on CPCI-6020. Since the Z85230 does not have all modem control lines, a Z8536 CIO is used to provide the missing modem lines. All modem control lines from the ESCC are multiplexed/demultiplexed through J3 by the P2MX function due to I/O pin limitations.

This hardware function is transparent to software. The block diagram for the signal multiplexing on the CPCI-6020-MCPTM-01 is shown in the following figure:

Figure 4-3 Serial Port Signal Multiplexing

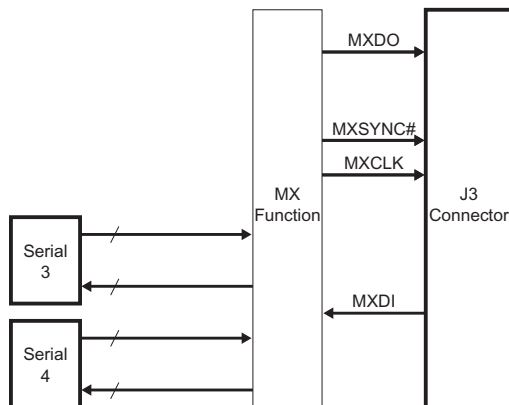

## 4.19 I/O Signal Multiplexing (IOMUX)

The IOMUX function is implemented on the CPCI-6020-MCPTM-01 using a PLD. A similar device exists on the CPCI-6020. There are four pins that are used for the IOMUX function: MXCLK, MXSYNC#, MXDO and MXDI. MXCLK is the 10 MHz bit clock for the time-multiplexed data lines MXDO and MXDI. MXSYNC# is asserted for one bit time at Time Slot 15 by the CPCI-

6020. MXSYNC# is used by the CPCI-6020-MCPTM-01 to synchronize with the CPCI-6020 module. MXDO is the time-multiplexed output line from the CPCI-6020 and MXDI is the time-multiplexed line from the CPCI-6020-MCPTM-01. A 16-to-1 multiplexing scheme is used with 10 MHz bit rate. Sixteen time slots are defined and allocated as follows:

Table 4-7 Multiplexing Sequence of the IOMUX Function

MXDO (From CPCI-6020)		MXDI (From CPCI-6020-MCPTM-01)	
TIME SLOT	SIGNAL NAME	TIME SLOT	SIGNAL NAME
0	RTS3	0	CTS3
1	DTR3	1	DSR3
2	LLB3	2	DCD3
3	RLB3	3	TM3
4	RTS4	4	RI3
5	DTR4	5	CTS4
6	LLB4	6	DSR4
7	RLB4	7	DCD4
8	Reserved	8	TM4
9	Reserved	9	RI4
10	Reserved	10	Reserved
11	Reserved	11	Reserved
12	Reserved	12	Reserved
13	Reserved	13	Reserved
14	Reserved	14	Reserved
15	Reserved	15	Reserved

MXSYNC# is clocked out using the falling edge of MXCLK and MDXO is clocked out with the rising edge of the MXCLK. MXDI is sampled at the rising edge of MXCLK (the CPCI-6020 MTB synchronizes MXDI with MXCLK's rising edge). The timing relationships among MXCLK, MXSYNC#, MXDO and MXDI are illustrated by the following figure:

Figure 4-4 P2MX Signal Timings

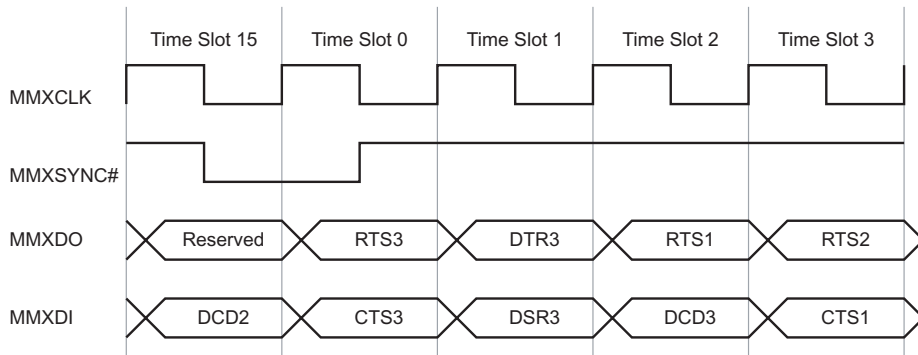

## 4.20 Serial Interface Modules (SIM)

The synchronous serial ports on the CPCI-6020-MCPTM-01 are configured via serial interface modules (SIMs), used in conjunction with the appropriate jumper settings on the transition module. The SIMs are small, plug-in printed circuit boards which contain all the circuitry needed to convert a TTL-level port to the standard voltage levels needed by various industry-standard serial interfaces, such as EIA-232, EIA-530, etc.

## 4.21 PMC Interface Module (PIM)

The CPCI-6020-MCPTM-01 provides additional I/O capabilities for the CPCI-6020. There are two distinct groups of I/O passed from the CPCI-6020 to the CPCI-6020-MCPTM-01 through the CompactPCI J3 and J5 connectors, CPCI-6020 host I/O and PMC I/O. The host I/O functions are designed into the CPCI-6020 and their presence or absence is determined when that board is built. This I/O cannot be configured at the system integration level. PMC I/O

depends entirely upon which, if any, PMC is installed in the CPCI-6020 PMC site. To accommodate the pluggable nature of a PMC, a custom form factor pluggable I/O module is presented here. A physical representation of the CPCI-6020-MCPTM-01 and a I/O module sample is shown below.

Figure 4-5 PMC Interface Module Layout

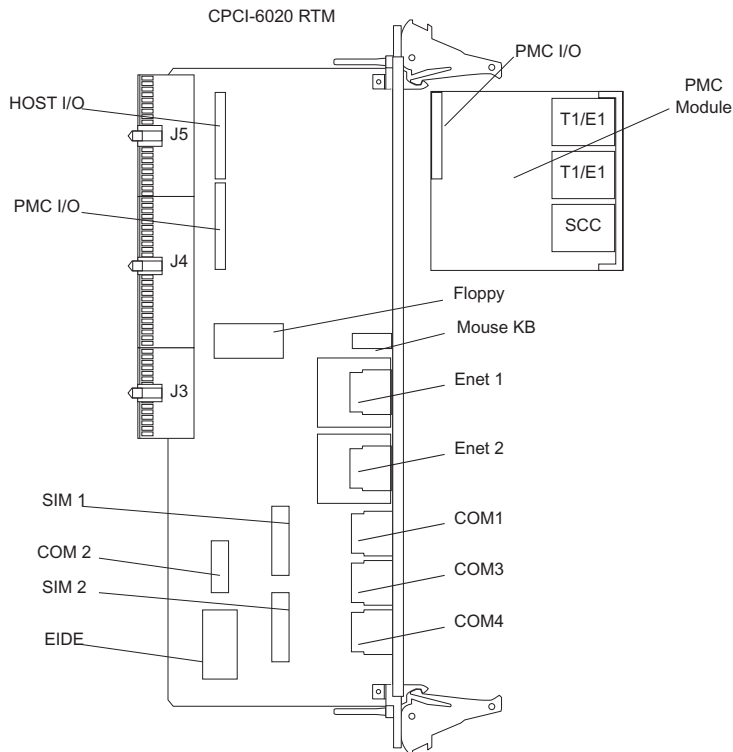

## 4.22 PMC Interface Module Form Factor

The PMC Interface Module (PIM) form factor, as defined by the VITA36 standard, is identical to the single-wide PMC form factor, with the following differences:

- Shorter by 80 mm
- Deletes the +5 V and +3.3 V keys
- Pn1 and Pn3 are deleted

The 80 mm is cut out of the middle of the PIM. This means that it preserves all the features near the front edge of the board as well as the features close to the back of the board without keeping the complete middle portion of the board (80 mm less).



## 4.23 PMC Interface Connector

The mapping used by the CPCI-6020 of the PMC I/O connectors onto the CompactPCI user I/O connectors is reversed by the CPCI-6020-MCPTM-01. This allows the designer of a PMC to create a PIM without knowledge of how the CPCI-6020 maps signals through the backplane. There is nothing to tie the PIM to the CPCI-6020 platform and in this sense the module is universal.

## 4.24 Host I/O Connector

The second connector on the PMC I/O module is used to provide power and ground to the module. In addition, the remaining pins may be used for host I/O signals. Any host I/O functionality for which there is no space available, or which the cost of does not justify its presence on the standard board, may be implemented in a host I/O module. This functionality is special to the host (in this case the CPCI-6020) and so the host I/O module is not a universal module. However, if the host I/O connector pinout is reused on future modular transition boards, the host I/O module may be reused.

If possible, optional host I/O routed to the host I/O connector will be terminated in such a fashion that the host does not incorrectly determine that a device is connected to that I/O when no module is present. This termination must not interfere with normal operation of the I/O when a module is present.

## 4.25 Speaker Port

The 2-pin header provides connection to an external speaker from the CPCI-6020 speaker counter output.

## 4.26 Floppy Disk Port

The CPCI-6020 uses the PC97307 ISASIO from National Semiconductor to provide a floppy disk controller. The interface is routed to the CompactPCI J5 connector. The CPCI-6020-MCPTM-01 brings the signals to a planar 34-pin header on board. Refer to the PC97307 data sheet for further details. This feature is supported only in the 5E variant.

## 4.27 Mouse and Keyboard Port

The CPCI-6020 uses the PC97307 ISASIO from National Semiconductor to provide a PS/2 mouse/keyboard interface which is routed to the CompactPCI J5 connector. The CPCI-6020-MCPTM-01 brings the signals to a PS/2 mouse/keyboard port on the real panel. Refer to the PC97307 data sheet for further details. This feature is supported only in the 5E variant.



## 5.1 PPCBug Overview

The PPCBug firmware is the layer of software just above the hardware. The firmware provides the proper initialization for the devices on the CPCI-6020 baseboard upon power-up or reset. The examples in this chapter show PPCBug as the prompt; for the CPCI-6020 baseboard the actual debugger prompt will be displayed as `MCP820Bug>`.

This chapter describes the basics of PPCBug and its architecture. It also describes the monitor (interactive command portion of the firmware) in detail, and describes how to use the PPCBug debugger and its special commands. A complete list of PPCBug commands appears at the end of the chapter. [Chapter 8, CNFG and ENV Commands](#) contains information about the CNFG and ENV commands (refer to [Table 5-1 on page 111](#)), system calls and other advanced user topics.

For full user information about PPCBug, refer to the *PPCBug Firmware Package User's Manual* and the *PPCBug Diagnostics User's Manual*, listed in [Appendix A, Related Documentation](#).

## 5.2 PPCBug Basics

The debug firmware, PPCBug, is a powerful evaluation and debugging tool that provides facilities for loading and executing user programs under complete operator control for system evaluation.

PPCBug provides a high degree of functionality, user friendliness, portability and ease of maintenance. Furthermore, PPCBug is portable and easy to understand because it was written in the C programming language, except where necessary to use assembler functions.

PPCBug includes commands for:

- Display and modification of memory
- Breakpoint and tracing capabilities
- A powerful assembler and disassembler useful for patching programs
- A self-test at power-up feature which verifies the integrity of the system

PPCBug consists of three parts:

- The debugger or PPCBug, which refers to the command-driven, user-interactive software debugger
- The diagnostics, which refers to the command-driven diagnostics package for the CPCI-6020 hardware
- A user interface or debug/diagnostics monitor that accepts commands from the system console terminal

When using PPCBug, you operate out of either the debugger directory or the diagnostic directory.

- If you are in the debugger directory, the debugger prompt PPC-Bug> is displayed and you have all of the debugger commands at your disposal
- If you are in the diagnostic directory, the diagnostic prompt PPC-Diag> is displayed and you have all of the diagnostic commands at your disposal as well as all of the debugger commands

Use the `SD` command to go back and forth between these directories.

Because PPCBug is command-driven, it performs its various operations in response to user commands entered at the keyboard. When you enter a command, PPCBug executes the command and the prompt reappears. However, if you enter a command that causes execution of user target code (for example, `GO`), then control may or may not return to PPCBug, depending on the outcome of the user program.

## 5.3 Memory Requirements

PPCBug requires a minimum of 1 MB of read/write memory (that is, DRAM for its own data storage purposes). The debugger allocates this space from the top of memory. The amount of memory that PPCBug is allowed to allocate for its own use is controlled by an NVRAM tunable value. For example, a system containing 64 MB (\$04000000) of read/write memory, using 1 MB of memory, will place the PPCBug memory page at locations \$03F00000 to \$03FFFFFF. In addition, PPCBug will use certain parts of low memory (typically from \$0 to \$4000) for exception vector table data. Avoid using any predefined address space in order to alleviate writing over any existing firmware code or data.

## 5.4 PPCBug Implementation

PPCBug is written largely in the C programming language, providing benefits of portability and maintainability. Where necessary, assembly language has been used in the form of separately compiled program modules containing only assembler code. No mixed-language modules are used.

Physically, PPCBug is contained in two socketed 32-pin PLCC flash devices that together provide 1 MB of storage. The executable code is checksummed at every power-on or reset firmware entry, and the result (which includes a precalculated checksum contained in the flash devices), is verified against the expected checksum.

## 5.5 MPU, Hardware and Firmware Initialization

The debugger performs the MPU, hardware and firmware initialization process. This process occurs each time the CPCI-6020 is reset or powered up. The steps below are a high-level outline (not all of the detailed steps are listed):

1. Sets MPU.MSR to a known value.
2. Invalidates the MPU's data/instruction caches.

3. Clears all segment registers of the MPU.
4. Clears all block address translation registers of the MPU.
5. Initializes the MPU-bus-to-PCI-bus bridge device.
6. Initializes the PCI-bus-to-ISA-bus bridge device.
7. Calculates the external bus clock speed of the MPU.
8. Delays for 750 milliseconds.
9. Determines the CPU board type.
10. Sizes the local read/write memory (i.e., DRAM).
11. Initializes the read/write memory controller.
12. Sets base address of memory to \$00000000.
13. Retrieves the speed of read/write memory.
14. Initializes the read/write memory controller with the speed of read/write memory.
15. Retrieves the speed of read only memory (i.e., flash) from NVRAM.
16. Initializes the read only memory controller with the speed of read only memory.
17. Enables the MPU's instruction cache.
18. Copies the MPU's exception vector table from \$FFF00000 to \$00000000.
19. Verifies MPU type.
20. Determines the debugger's console/host ports, and initializes the appropriate devices (PC16550/GD54xx/Z85C230).
21. Displays the debugger's copyright message.
22. Displays any hardware initialization errors that may have occurred.
23. Checksums the debugger object, and displays a warning message if the checksum failed to verify.
24. Displays the amount of local read/write memory found.
25. Verifies the configuration data that is resident in NVRAM, and displays a warning message if the verification failed.
26. Calculates and displays the MPU clock speed, verifies that the MPU clock speed matches the configuration data and displays a warning message if the verification fails.
27. Displays the BUS clock speed, verifies that the BUS clock speed matches the configuration data and displays a warning message if the verification fails.
28. Probes PCI Bus for supported network devices.
29. Probes PCI Bus for supported mass storage devices.
30. Initializes the memory/IO addresses for the supported PCI Bus devices.
31. Executes Self-Test, if so configured. (Default is no Self-Test.)
32. Extinguishes the board fail LED, if there are no self-test failures or initialization/configuration errors.

33. Executes the configured boot routine, either ROMboot, Autoboot or Network Autoboot.
34. Executes the user interface (displays the `PPC-Bug>` or `PPC-Diag>` prompt).

## 5.6 Using PPCBug

PPCBug is command-driven. It performs its various operations in response to commands entered at the keyboard. When the `PPC-Bug` prompt appears on the screen, the debugger is ready to accept debugger commands. When the `PPC-Diag` prompt appears on the screen, the debugger is ready to accept diagnostic commands. To change from one mode to the other, enter `SD`.

Keyboard entries are stored in an internal buffer and only execute after the Return or Enter key is pressed. This feature provides time to correct entry errors, if necessary, with the control characters described in the *PPCBug Firmware Package User's Manual*.

After the debugger executes the command, the prompt reappears. However, if the command causes execution of user target code (for example `GO`) then control may or may not return to the debugger, depending on what the user program does. For example, if a breakpoint is specified, control returns to the debugger when the breakpoint is encountered during execution of the user program. However, the user program can return to the debugger by means of the System Call Handler routine `RETURN`. For more about this, refer to the `GD`, `GO` and `GT` command descriptions in the *PPCBug Firmware Package User's Manual*.

A debugger command is made up of the following parts:

- The command name, either uppercase or lowercase (e.g., `MD` or `md`)
- Any required arguments, as specified by command
- At least one space before the first argument. Precede all other arguments with either a space or comma
- One or more options, precede an option or a string of options with a semicolon (;). If no option is entered, the command's default option conditions are used

## 5.7 Debugger Commands

The individual debugger commands are listed in the following table. The commands are described in detail in the *PPCBug Firmware Package User's Manual*.

You can list all the available debugger commands by entering the `Help (HE)` command alone. You can view the syntax (description) for a particular command by entering `HE` followed by a space, followed by the particular command mnemonic (as listed below), followed by a carriage return. Remember that help is now available on both the `BUG` and `DIAG` side. In addition, issuing help on a `DIAG` test category gives more information about the tests in that category.

The later is accomplished by entering `HE`, followed by a space, followed by the test category description (e.g., UART), followed by a carriage return.

Table 5-1 Debugger Commands

Command	Description
AS	Assembler
BC	Block of Memory Compare
BF	Block of Memory Fill
BFL	Flash Board Fail LED If Diagnostic Errors
BI	Block of Memory Initialize
BM	Block of Memory Move
BS	Block of Memory Search
BR	Breakpoint Insert
BV	Block of Memory Verify
CACHE	Modify Cache State
CM	Concurrent Mode
CNFG	Configure Board Information Block
CS	Checksum a Block of Data
CSAR	PCI Configuration Space READ Access
CSAW	PCI Configuration Space WRITE Access
DC	Data Conversion and Expression Evaluation
DS	Disassembler
DU	Dump S-Records
ECHO	Echo String
ENV	Set Environment to Bug/Operating System
FORK	Fork Idle MPU at Address
FORKWR	Fork Idle MPU with Registers
G	"Alias" for "GO" Command
GD	Go Direct (Ignore Breakpoints)
GEVBOOT	Global Environment Variable Boot - Bootstrap Operating System
GEVDEL	Global Environment Variable Delete
GEVDUMP	Global Environment Variable(s) Dump (NVRAM Header + Data)
GEVEDIT	Global Environment Variable Edit
GEVINIT	Global Environment Variable Area Initialize (NVRAM Header)
GEVSHOW	Global Environment Variable Show
GN	Go to Next Instruction
GO	Go Execute User Program
GT	Go to Temporary Breakpoint

Table 5-1 Debugger Commands (continued)

Command	Description
HE	Help on Command(s)
IBM	Indirect Block Move
IDLE	Idle Master MPU
IOC	I/O Control for Disk
IOI	I/O Inquiry
IOP	I/O Physical to Disk
IOT	I/O "Teach" for Configuring Disk Controller
IRD	Idle MPU Register Display
IRM	Idle MPU Register Modify
IRS	Idle MPU Register Set
LO	Load S-Records from Host
M	"Alias" for "MM" Command
MA	Macro Define/Display
MAE	Macro Edit
MAL	Enable Macro Expansion Listing
MAR	Macro Load
MAW	Macro Save
MD	Memory Display
MENU	System Menu
MM	Memory Modify
MMD	Memory Map Diagnostic
MMGR	Access Memory Manager
MS	Memory Set
MW	Memory Write
NAB	Network Automatic Bootstrap Operating System
NAP	Nap MPU
NBH	Network Bootstrap Operating System and Halt
NBO	Network Bootstrap Operating System
NIOC	Network I/O Control
NIOP	Network I/O Physical
NIOT	I/O "Teach" for Configuring Network Controller
NOBR	Breakpoint Delete
NOCM	No Concurrent Mode
NOMA	Macro Delete
NOMAL	Disable Macro Expansion Listing
NOPA	Printer Detach



Table 5-1 Debugger Commands (continued)

Command	Description
NOF	Port Detach
NORB	No ROM Boot
NOSYM	Detach Symbol Table
NPING	Network Ping
OF	Offset Registers Display/Modify
PA	Printer Attach
PBOOT	Bootstrap Operating System
PCIDOM	PCI Domain Control
PCIOI	PCI Slot Status Display
PEEPROM	Read/Write/Verify the HSC/Bridge's EEPROM
PF	Port Format
PFLASH	Program FLASH Memory
PS	Put RTC Into Power Save Mode for Storage
PWROFF	Power Off PCI Slot/Power Supply/Peripheral Bay
PWRON	Power On PCI Slot/Power Supply/Peripheral Bay
RB	ROM Bootstrap Operating System
RD	Register Display
REMOTE	Connect the Remote Modem to CSO
RESET	Cold/Warm Reset
RL	Read Loop
RM	Register Modify
RS	Register Set
RUN	MPU Execution/Status
SD	Switch Directories
SET	Set Time and Date
SROM	SROM Examine/Modify
SYM	Attach Symbol Table
SYMS	Display Symbol Table
T	Trace
TA	Terminal Attach
TIME	Display Time and Date
TM	Transparent Mode
TT	Trace to Temporary Breakpoint
UPDATE	Update SROMs
VE	Verify S-Records Against Memory
VER	Revision/Version Display

Table 5-1 Debugger Commands (continued)

Command	Description
WL	Write Loop

## NOTICE

### Data Loss

Although a command that allows erasing and reprogramming of flash memory is available, note that reprogramming any portion of the CPCI-6020 baseboard's flash memory (Bank B) will erase everything currently contained in the baseboard flash, including the PPCBug debugger.

Use caution when reprogramming or erasing flash memory. Refer to the programming documents listed in [Appendix A, Related Documentation](#).

## 5.8 Diagnostic Tests

The PPCBug hardware diagnostics are intended for testing and troubleshooting the CPCI-6020 module.

In order to use the diagnostics, you must change to the diagnostic directory. You may change between directories by using the `SD` (Switch Directories) command. You may view a list of the commands in the directory that you are currently in by using the `HE` (Help) command.

If you are in the debugger directory, the debugger prompt `PPC-Bug>` displays, and all of the debugger commands are available. Diagnostics commands cannot be entered at the `PPC-Bug>` prompt.

If you are in the diagnostic directory, the diagnostic prompt `PPC-Diag>` displays, and all of the debugger and diagnostic commands are available.

Note that not all tests are valid for the CPCI-6020. Using the `HE` command, you can list the diagnostic routines available in each test group. Refer to the *PPCBug Diagnostics Manual* for complete descriptions of the diagnostic routines and instructions on how to invoke them.

You may enter command names in either uppercase or lowercase.

Some diagnostics depend on restart defaults that are set up only in a particular restart mode. Refer to the documentation on a particular diagnostic for the correct mode.

Some test groups have subtests. For example, enter the command `PPC-Bug>he ram` to access the RAM test group subtests. This will display the subtests, which you can run separately as RAM tests.

Test sets marked with an asterisk (\*) are not available on the CPCI-6020, unless SCSI or video PMCs are installed.

*Table 5-2 Diagnostic Test Groups*

Test Set	Description
CL1283	Parallel Interface (CL1283)
DEC	DECchip 21x4x EIDE Tests
ISABRDGE	PCI/ISA Bridge Tests
KBD8730x	PC8730x Keyboard/Mouse Tests*
L2CACHE	Level 2 Cache Tests
NCR	NCR 53C8xx SCSI-2 I/O Processor Tests*
PAR8730x	PC8730x Parallel Port Test*
PCIBUS	Generic PCI/PMC Slot Test
RAM	Random Access Memory Tests
RTC	MK48Txx Real-Time Clock Tests
SCC	Serial Communications Controller Tests
UART	Serial Input/Output UART Tests
VGA54xx	Video Graphics Tests*
Z8536	Zilog Z8536 Counter/Timer Tests*



## 6.1 Overview

The RAM500 memory expansion module is used on the CPCI-6020 as its on-board memory capability. No on-board memory exists on the CPCI-6020; therefore, the CPCI-6020 will not function properly without at least one RAM500 memory module installed.

Each expansion module is a single bank of SDRAM with up to 512 MB of available ECC memory. Currently, you can use two expansion modules in tandem to produce an additional expanded memory capability of 1 GB per memory module site. (In the case of the CPCI-6020, two memory module sites exist for a potential of 2 GB of memory.

There are two configurations of the board to accommodate tandem usage:

- The bottom expansion module has both a bottom and top connector, one to plug into the baseboard and one to mate with the second RAM500 module.
- The top expansion module is designed with just a bottom connector to plug into the lower RAM500 module.

The RAM500 incorporates a Serial ROM for system memory Serial Presence Detect (SPD) data.

A maximum of two expansion modules per memory mezzanine site are allowed: one bottom and one top. If only one module is used, the RAM500 module with the top configuration is recommended.

## 6.2 RAM500 Description

The RAM500 is a memory expansion module that is used on the CPCI-6020 Single Board Computer, as well as other Motorola products. The RAM500 is based on a single memory mezzanine board design with the flexibility of being populated with different sized SDRAM components and SPD options to provide a variety of memory configurations. The design of the RAM500 allows any memory size module to connect to and operate with any other available memory size module.

The optional RAM500 memory expansion module is currently available in three sizes: 128 MB, 256 MB and 512 MB. The SDRAM memory is controlled by the Hawk or Harrier ASIC, which provides single-bit error correction and double-bit error detection. ECC is calculated over 72-bits. Refer to the *CPCI-6020 Single Board Computer Programmer's Reference Guide* and the *Harrier Application Specific Integrated Circuit (ASIC) Programmer's Reference Guide* for more information.

The RAM500 consists of a single bank/block of memory. The memory block size is dependent upon the SDRAM devices installed. Refer to [Table 6-1](#) for memory options.

The RAM500 memory expansion module is connected to the host board with a 140-pin AMP 0.6mm Free Height plug connector. If the expansion module is designed to accommodate another RAM500 module, the bottom expansion module will have two 140-pin AMP connectors installed: one on the bottom side of the module, and one on the top side of the module. The RAM500 memory expansion module draws +3.3 V through this connector.

When populated, the optional RAM500 memory expansion memory blocks should appear as Block C and Block E to the ASIC. Block C and E are used because each of the module's SPD is defined to correspond to two banks of memory each: C and D for the first SPD and E and F for the second SPD.

The RAM500 SPD uses the SPD JEDEC standard definition and is accessed at address \$AA or \$AC. Refer to the following section on SROM for more details.

*Table 6-1 RAM500 SDRAM Memory Size Options*

RAM500 Memory Size	Device Size	Device Organization	Number of Devices
128 MB	256 megabit	16Mx16	5*
128 MB	128 megabit	16Mx8	9
256 MB	256 megabit	32Mx8	9
512 MB	512 megabit	64Mx8	9

## 6.3 RAM500 Module Installation

### Procedure

One or more RAM500 memory expansion modules must be mounted on top of the CPCI-6020 for on-board memory capability. To upgrade or install a RAM500 module, follow these steps.

1. Attach an ESD strap to your wrist. Attach the other end of the ESD strap to the chassis as a ground. The ESD strap must be secured to your wrist and to ground throughout the procedure.
2. Perform an operating system shutdown. Turn the AC or DC power off and remove the AC cord or DC power lines from the system. Remove the chassis or system cover(s) as necessary for access to the CompactPCI boards.
3. Carefully remove the CPCI-6020 from its CompactPCI card slot and lay it flat, with connectors P1 through P5 facing you, or simply unpack the CPCI-6020 from its shipping container and lay it flat as described.
4. Inspect the RAM500 module that is being installed on the CPCI-6020 host board (bottom configuration if two are being installed, top configuration if only one is being installed) to ensure that standoffs are installed in the three mounting holes on the module.

5. With standoffs installed in the three mounting holes on the RAM500 module, align the standoffs and the P1 connector on the module with the three holes on the J7 or J28 connector on the CPCI-6020 host board and press the two connectors together until they are firmly seated in place.
6. (Optional step) If a second RAM500 module is being used, align the top connector on the bottom RAM500 module with the bottom connector on the top RAM500 module and press the two connectors together until the connectors are seated in place.
7. Insert the three short Phillips screws through the holes at the corners of the RAM500 and screw them into the standoffs.
8. Turn the entire assembly over, and fasten the three nuts provided to the standoff posts on the bottom of the CPCI-6020 host board.
9. Reinstall the CPCI-6020 assembly in its proper card slot. Be sure the host board is well seated in the backplane connectors. Do not damage or bend connector pins.
10. Replace the chassis or system cover(s), reconnect the system to the AC or DC power source and turn the equipment power on.

## 6.4 Features

The following table lists the features of the RAM500 memory expansion module:

*Table 6-2 RAM500 Feature Summary*

Feature	Description
Form Factor	Dual sided mezzanine, with screw/post attachment to host board
SROM	Single 256x8 I <sup>2</sup> C SROM for Serial Presence Detect Data
SDRAM	Double-Bit-Error detect, Single-Bit-Error correct across 72 bits 128 MB to 512 MB mezzanine memory @ 100 MHz as a goal
Memory Expansion Flexibility	Any RAM500 memory size can be attached to the host board followed by any secondary RAM500 memory size for maximum memory expansion flexibility.

### 6.4.1 SROM

The RAM500 memory expansion module contains a single +3.3 V, 256 x 8, Serial EEPROM device (AT24C02). The Serial EEPROM provides Serial Presence Detect (SPD) storage of the module memory subsystem configuration. The RAM500 SPD is software addressable by a unique address as follows: The first RAM500 attached to the host board has its SPD addressable at \$AA. The second RAM500 attached to the host board has its SPD addressable at \$AC. This dynamic address relocation of the RAM500 SPD shall be done using the bottom-side connector signal A1\_SPD and A0\_SPD.

## 6.4.2 Host Clock Logic

The host board provides four SDRAM clocks to the memory expansion connector. The frequency of the RAM500 CLKS is the same as the host board.

## 6.4.3 Serial Presence Detect (SPD) Data

This register is partially described for the RAM500 within the *CPCI-6020 Single Board Computer Programmer's Reference Guide*. The register is accessed through the I<sup>2</sup>C interface of the Harrier ASIC on the host board (CPCI-6020). The RAM500 SPD is software addressable by a unique address as follows: The first RAM500 attached to the host board has an SPD address of \$AA. The second RAM500 attached to the top of the first RAM500 has an SPD address of \$AC.

## 6.5 RAM500 Connectors

RAM500 memory expansion modules are populated with one or two connectors. If the module is to be used in tandem with a second RAM500 module, the “bottom” module will have two connectors: one to mate with the CPCI-6020 host board (P1), and one to mate with the top RAM500 module (J1). The top RAM500 module has only one connector, since it needs to mate only with the RAM500 module directly underneath it and because an added connector on a tandem RAM500 configuration would exceed the height limitations in some backplanes. If only one RAM500 module is being used, a top module, single connector configuration is used.

A 4H plug and receptacle are used on both boards to provide a 4 millimeter stacking height between dual RAM500 cards and the host board.

The following subsections specify the pin assignments for the connectors on the RAM500.

### 6.5.1 Bottom Side Memory Expansion Connector (P1)

The bottom side connector on the RAM500 is a 140-pin AMP 0.6 mm Free Height mating plug. This plug includes common ground contacts that mate with standard AMP receptacle assemblies or AMP GIGA assemblies with ground plates. A single memory expansion module will have 1 bank of SDRAM for a maximum of 256 MB of memory. Attaching a second memory module to the first module will provide 2 banks of SDRAM with a maximum of 512 MB.

*Table 6-3 RAM500 Bottom Side Connector (P1) Pin Assignments*

Pin	Signal	Signal	Pin
1	GND*	GND*	2
3	DQ00	DQ01	4
5	DQ02	DQ03	6
7	DQ04	DQ05	8
9	DQ06	DQ07	10
11	+3.3 V	+3.3 V	12



Table 6-3 RAM500 Bottom Side Connector (P1) Pin Assignments  
(continued)

Pin	Signal	Signal	Pin
13	DQ08	DQ09	14
15	DQ10	DQ11	16
17	DQ12	DQ13	18
19	DQ14	DQ15	20
21	GND*	GND*	22
23	DQ16	DQ17	24
25	DQ18	DQ19	26
27	DQ20	DQ21	28
29	DQ22	DQ23	30
31	+3.3 V	+3.3 V	32
33	DQ24	DQ25	34
35	DQ26	DQ27	36
37	DQ28	DQ29	38
39	DQ30	DQ31	40
41	GND*	GND*	42
43	DQ32	DQ33	44
45	DQ34	DQ35	46
47	DQ36	DQ37	48
49	DQ38	DQ39	50
51	+3.3 V	+3.3 V	52
53	DQ40	DQ41	54
55	DQ42	DQ43	56
57	DQ44	DQ45	58
59	DQ46	DQ47	60
61	GND*	GND*	62
63	DQ48	DQ49	64
65	DQ50	DQ51	66
67	DQ52	DQ53	68
69	+3.3 V	+3.3 V	70
71	DQ54	DQ55	72
73	DQ56	DQ57	74
75	DQ58	DQ59	76
77	DQ60	DQ61	78
79	GND*	GND*	80
81	DQ62	DQ63	82

Table 6-3 RAM500 Bottom Side Connector (P1) Pin Assignments  
(continued)

Pin	Signal	Signal	Pin
83	CKD00	CKD01	84
85	CKD02	CKD03	86
87	CKD04	CKD05	88
89	+3.3 V	+3.3 V	90
91	CKD06	CKD07	92
93	BA1	BA0	94
95	A12	A11	96
97	A10	A09	98
99	GND*	GND*	100
101	A08	A07	102
103	A06	A05	104
105	A04	A03	106
107	A02	A01	108
109	+3.3 V	+3.3 V	110
111	A00	CS_C0_L	112
113	CS_E0_L	GND*	114
115	CS_C1_L	CS_E1_L	116
117	WE_L	RAS_L	118
119	GND*	GND*	120
121	CAS_L	+3.3 V	122
123	+3.3 V	DQMB0	124
125	DQMB1	SCL	126
127	SDA	A1_SPD	128
129	A0_SPD	MEZZ1_L	130
131	MEZZ2_L	GND	132
133	GND	SDRAMCLK1	134
135	SDRAMCLK3	+3.3 V	136
137	SDRAMCLK4	SDRAMCLK2	138
139	GND*	GND*	140

\*Common GND pins mate to a GIGA assembly with a ground plate. The GIGA assembly is an enhanced electrical performance receptacle and plug from AMP that includes receptacles loaded with contacts for grounding circuits at 9 or 10 signal circuits. These ground contacts mate with grounding plates on both sides of the plug assemblies.

## 6.5.2 Top Side Memory Expansion Connector (J1)

The top side memory expansion connector is a 140-pin AMP 0.6 mm Free Height receptacle. This receptacle includes common ground contacts that mate with standard AMP plug assemblies or AMP GIGA assemblies with ground plates. A single memory module will have one bank of SDRAM for a maximum of 256 MB of memory. The pin assignments for this connector are as follows:

Table 6-4 RAM500 Top Side Connector (J1) Pin Assignments

Pin	Signal	Signal	Pin
1	GND*	GND*	2
3	DQ00	DQ01	4
5	DQ02	DQ03	6
7	DQ04	DQ05	8
9	DQ06	DQ07	10
11	+3.3 V	+3.3 V	12
13	DQ08	DQ09	14
15	DQ10	DQ11	16
17	DQ12	DQ13	18
19	DQ14	DQ15	20
21	GND*	GND*	22
23	DQ16	DQ17	24
25	DQ18	DQ19	26
27	DQ20	DQ21	28
29	DQ22	DQ23	30
31	+3.3 V	+3.3 V	32
33	DQ24	DQ25	34
35	DQ26	DQ27	36
37	DQ28	DQ29	38
39	DQ30	DQ31	40
41	GND*	GND*	42
43	DQ32	DQ33	44
45	DQ34	DQ35	46
47	DQ36	DQ37	48
49	DQ38	DQ39	50
51	+3.3 V	+3.3 V	52
53	DQ40	DQ41	54
55	DQ42	DQ43	56
57	DQ44	DQ45	58

Table 6-4 RAM500 Top Side Connector (J1) Pin Assignments (continued)

Pin	Signal	Signal	Pin
59	DQ46	DQ47	60
61	GND*	GND*	62
63	DQ48	DQ49	64
65	DQ50	DQ51	66
67	DQ52	DQ53	68
69	+3.3 V	+3.3 V	70
71	DQ54	DQ55	72
73	DQ56	DQ57	74
75	DQ58	DQ59	76
77	DQ60	DQ61	78
79	GND*	GND*	80
81	DQ62	DQ63	82
83	CKD00	CKD01	84
85	CKD02	CKD03	86
87	CKD04	CKD05	88
89	+3.3 V	+3.3 V	90
91	CKD06	CKD07	92
93	BA1	BA0	94
95	A12	A11	96
97	A10	A09	98
99	GND*	GND*	100
101	A08	A07	102
103	A06	A05	104
105	A04	A03	106
107	A02	A01	108
109	+3.3 V	+3.3 V	110
111	A00	CS_E0_L	112
113		GND*	114
115	CS_E1_L		116
117	WE_L	RAS_L	118
119	GND*	GND*	120
121	CAS_L	+3.3 V	122
123	+3.3 V	DQMB1	124
125		SCL	126
127	SDA		128
129	A1_SPD	MEZZ2_L	130

Table 6-4 RAM500 Top Side Connector (J1) Pin Assignments (continued)

Pin	Signal	Signal	Pin
131		GND	132
133	GND	SDRAMCLK3	134
135		+3.3 V	136
137		SDRAMCLK4	138
139	GND*	GND*	140

\*Common GND pins mate to GIGA assemblies with ground plates.

## 6.6 RAM500 Programming Issues

The RAM500 contains no user programmable registers other than the Serial Presence Detect (SPD) Data.



## 7.1 Overview

This chapter provides hardware preparation and installation instructions, as well as pin assignment information for the CPCI-6020-MCPTM-01 transition module. The CPCI-6020-MCPTM-01 is an optional module that is used in conjunction with the CPCI-6020 series of Single Board Computers.

If you are using the CPCI-6020-MCPTM-01 with the CPCI-6020, ensure that you have performed all tasks as described in [Chapter 2, Hardware Preparation and Installation](#), prior to configuring and installing the CPCI-6020-MCPTM-01.

## 7.2 General Description

The CPCI-6020-MCPTM-01 provides additional I/O capabilities to the CPCI-6020 board. The CPCI-6020-MCPTM-01 is installed directly in the CompactPCI backplane in the rear transition board bay of the chassis and interfaces with the CPCI-6020 board through the J3 and J5 connectors.

It includes the following features:

- Secondary EIDE interface via J5 user I/O connector
- Dual 10BaseT/100BaseTX Ethernet capability
- Two asynchronous serial ports (COM1-rear and COM2-optional to rear)
- Two synchronous serial ports (COM3 and COM4)
- One PMC I/O module (PIM)
- Two Serial Interface Modules (SIMs)
- One floppy disk port
- One speaker port
- One mouse and keyboard port
- I/O signal multiplexing (IOMUX)

CPCI-6020-MCPTM-01 supports one single-wide (74 mm wide by 69 mm long) PMC Interface Module (PIM). PMC I/O pins 1 through 64 of the PMC interface are routed from the CPCI-6020 J3 and J5 connectors. For a detailed description of the PMC Interface Module see [PMC Interface Module \(PIM\) on page 100](#). Besides these, CPCI-6020-MCPTM-01 supports two synchronous Serial Interface Modules (SIMs).

Figure 7-1 Block Diagram

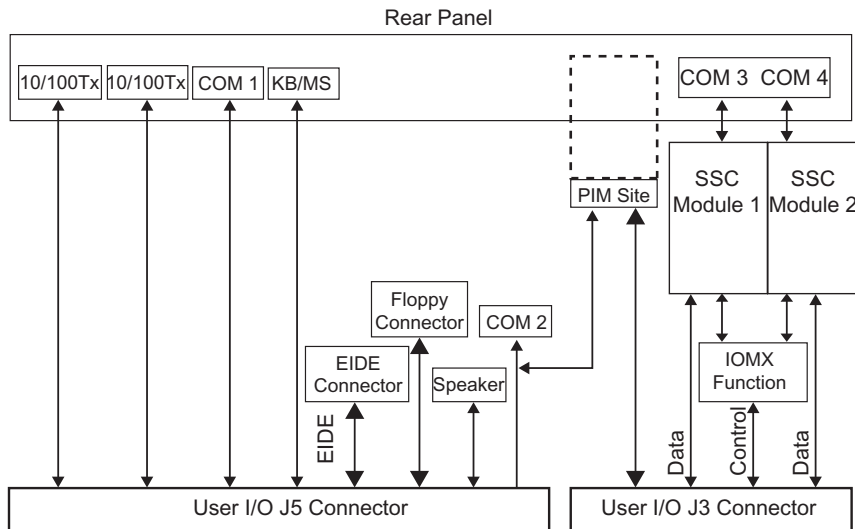



## 7.2.1 Component Layout

The next figure shows the layout of the CPC-6020-MCPTM-01 major components.

Figure 7-2 Component Layout

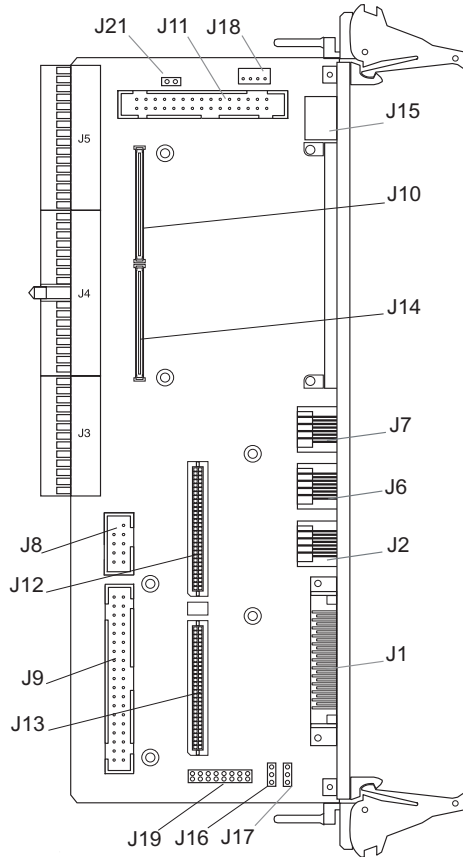

## 7.2.2 Rear Panel Connectors

The next figure shows the location of all connectors and the PMC cutout of the CPCI-6020-MCPTM-01.

Figure 7-3 Rear Panel Connectors, Cut-outs

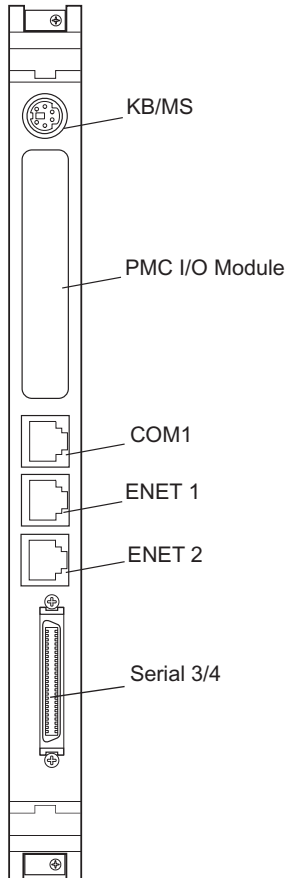

## 7.3 Unpacking and Inspecting the RTM

Read all notices and cautions prior to unpacking the product.

### NOTICE

#### Damage of Circuits

**Electrostatic discharge and incorrect installation and removal can damage circuits or shorten their life.**

**Before touching the AMC or electronic components, make sure that you are working in an ESD-safe environment.**

#### Shipment Inspection

To inspect the shipment, perform the following steps:

1. Verify that you have received all items of your shipment.
2. Check for damage and report any damage or differences to customer service.
3. Remove the desiccant bag shipped together with the board and dispose of it according to your country's legislation.



**The product is thoroughly inspected before shipment. If any damage occurred during transportation or any items are missing, contact customer service immediately.**

## 7.4 Preparing the Transition Module

Before installing the CPCI-6020-MCPTM-01, read these sections for important information on module configuration and operations.

### 7.4.1 Serial Ports 1 and 2

The CPCI-6020 provides two 16550 compatible asynchronous serial interfaces: COM1 and COM2. The COM1 port signals are wired to the front panel RJ-45 connector, but it may optionally be wired to the backplane via J5 instead. The COM2 port is wired to the J5 connector only.

COM1 is routed to an RJ-45 connector located at the rear panel of the CPCI-6020-MCPTM-01. COM2 can be accessed by a planar 9-pin header on the transition module. The COM2 signals are also wired to the PMC I/O connector for possible access through PMC I/O module.

These asynchronous serial ports (COM1 and COM2) are configured permanently as data circuit-terminating equipment (DTE). A terminal for COM1 may be connected to either the processor board or the transition module, but not both.

## 7.4.2 Serial Ports 3 and 4

The two synchronous serial ports, COM3 and COM4, are implemented with the Z85230 ESCC on the CPCI-6020. Since the Z85230 does not have all of the necessary modem lines, a Z8536 CIO is used to provide the missing modem lines. All modem control lines from the ESCC are multiplexed/demultiplexed through J3 by the P2MX function due to I/O pin limitations. Refer to [I/O Signal Multiplexing \(IOMUX\) on page 101](#) for more information. A special Y-adaptor cable is required for separating the signals from a 50-pin connector on the rear of the transition module to two 26-pin connectors for COM3 and COM4. Refer to [Table 7-3 on page 142](#) for cable description and part number.

The synchronous serial ports (Serial Ports 3 and 4) are configured through a combination of serial interface module (SIM) selection and jumper settings. A SIM is a small “plug-in” printed circuit board that converts the TTL-level synchronous or asynchronous port signals to industry standard voltage levels used by the ports. The SIM contains the receiver and transmitter circuits for converting the input and output signals of the host CPCI-6020 to the appropriate serial data communication protocol. The table below lists the SIM connectors and jumper headers corresponding to each of the synchronous serial ports.

Both Serial Port 3 and 4 are routed through connector J1.

*Table 7-1 SIM Model Numbers*

Interface	Model Number
EIA-232-D DCE	SIM232DCE6E
EIA-232-D DTE	SIM232DTE6E

The next table provides port and connector assignments for the board and SIMs

Synchronous Port	Board Connector	SIM Connector	Jumper Header
Port 3	J1 <sup>1</sup>	J12	J17
Port 4	J1	J13	J16

1. Requires Motorola’s specially designed Y-adaptor cable (30-W2046F02A) or similar customer designed adapter.

Refer to the pin assignment information following this section for connectors J1, J12 and J13, as well as other connectors.

Headers J17 and J16 are used to configure serial ports 3 and 4 respectively, in tandem with the proper SIM selection. With a jumper across pins 1 and 2 on either header, the port is configured as DTE. With a jumper across pins 2 and 3, the port is configured as DCE. It is important to note that the jumper setting of the port must match the configuration of the corresponding SIM module.

Figure 7-4 Ports 3 and 4 Header Settings

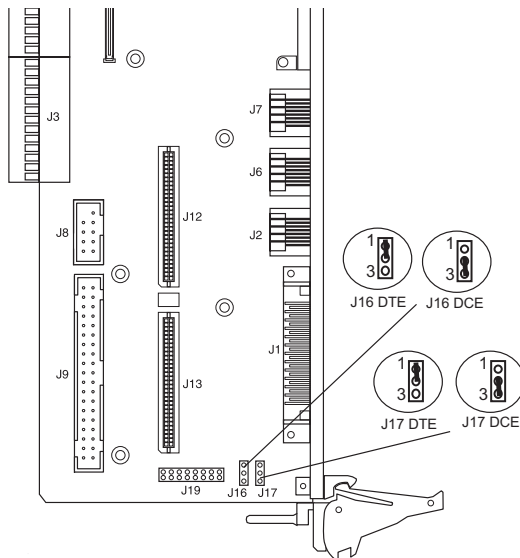

When installing the SIM modules, note that the headers are keyed for proper orientation. For further information on the preparation and installation of the transition module, refer to the following sections.

The next figures illustrate the CPCI-6020 baseboard and CPCI-6020-MCPTM-01 transition module with the interconnections and jumper settings for DCE/DTE configuration on each serial port.

### 7.4.3 Serial Interface Module Circuitry

Each Serial Interface Module (SIM) has a 60-pin connector that provides all signal and power connections to the CPCI-6020-MCPTM-01 transition module.

All TTL-level signals, with the exception of data and clocks, are active low. The pull-up resistors on the CPCI-6020-MCPTM-01 transition module drive all TTL inputs to the SIM to a known logic level.

The SIMs have surge suppression circuitry for all port signals going to the external connector. This consists of a series resistor and a dual 15 V clamp diode to chassis ground. All series resistors are 100 ohms.

The EIA-232-D SIMs employ MC145406 ICs as line transmitters to convert the TTL output signals from the CPCI-6020 module to EIA-232-D voltage levels. As line receivers, the MC145406 ICs convert the EIA-232-D input signals to TTL voltage levels which are sent to the CPCI-6020. For all port interfaces, the SIMs support the transmitter signal element timing as either input or output signals.

The MC145406 transceiver IC requires a series diode on the +12 V supply and a clamp diode to logic ground on the -12 V supply. The diodes are located on the transition module rather than on the SIM due to space limitation.

### 7.4.4 Port Configuration

The following interface configuration diagrams describe the interface between the CPCI-6020 and CPCI-6020-MCPTM-01.

Figure 7-5 EIA-232-D DCE Ports 3 and 4 Configuration

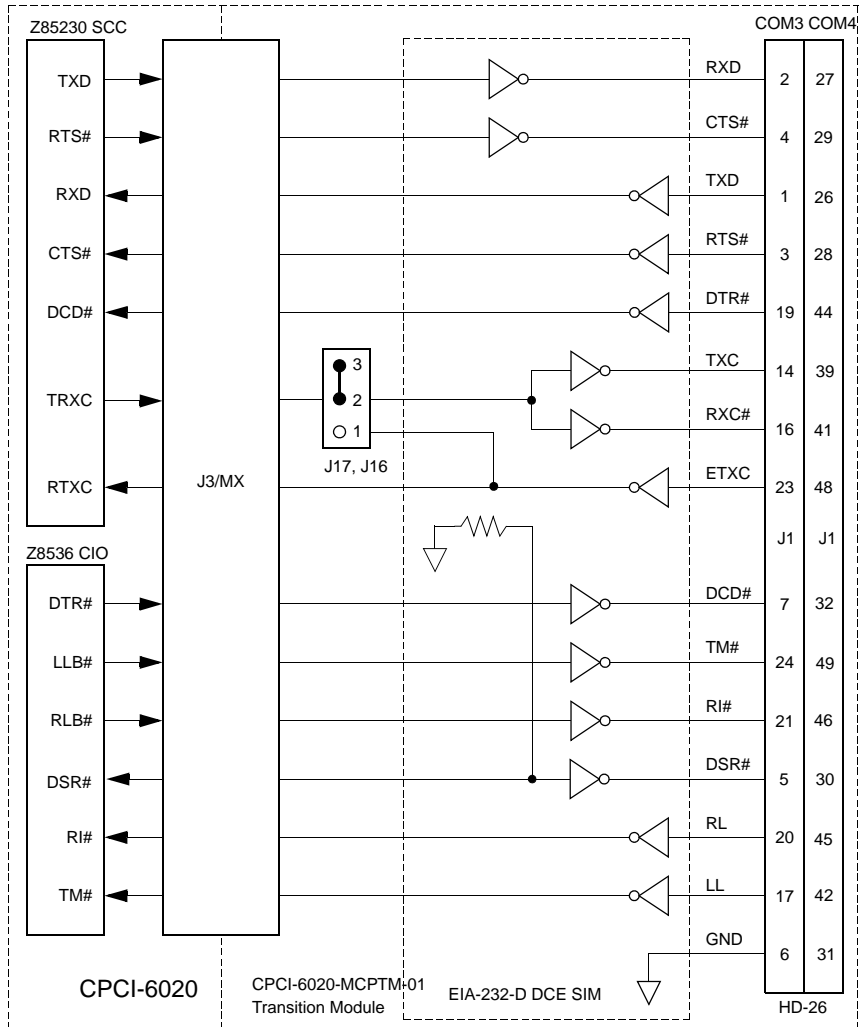
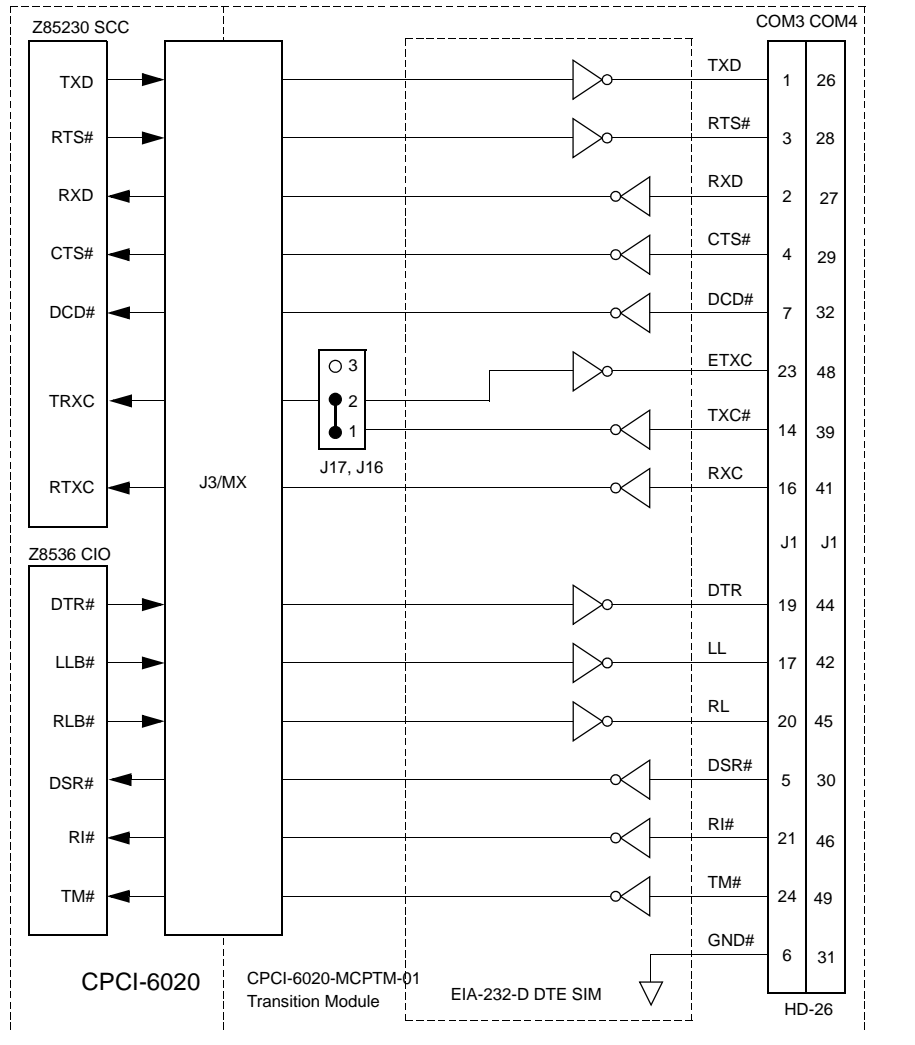

Figure 7-6 EIA-232-D DTE Ports 3 and 4 Configuration



## 7.5 Installing the SIMs

Configure the serial ports 3 and 4 (COM3/COM4) for the required interface by installing the appropriate SIM. Refer to [Table 7-3 on page 142](#) for a list of the serial port interface types.

Prior to installing the SIMs, be sure you have set the jumper(s) on J16 (for serial port 3) and/or J17 (for serial port 4), as described in the previous section for either DCE or DTE. The SIMs plug into connectors J12 (COM3) and J13 (COM4) on the CPCI-6020-MCPTM-01. Refer to [Figure 7-4 on page 133](#) for connector and header locations.

Install the SIMs on the CPCI-6020-MCPTM-01 transition module using the following procedure:



## Procedure

You must set the jumpers and install the SIMs prior to installing the CPCI-6020-MCPTM-01 transition module in the system chassis.

1. Align the SIM so that P1 on the SIM align with the appropriate SIM connector (J12 for COM3 and J13 for COM4) on the transition module. Note the position of the alignment key on P1. Refer to the following figure.

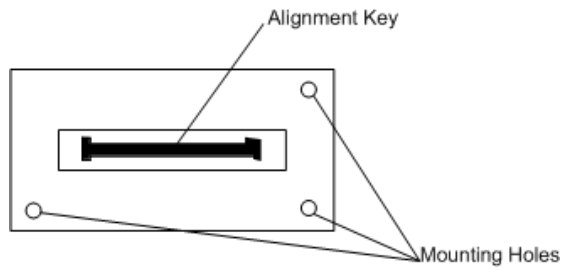

2. Place the SIM onto the transition module SIM connector, making sure that the mounting holes also align with the standoffs on the transition module as shown in the following figure.

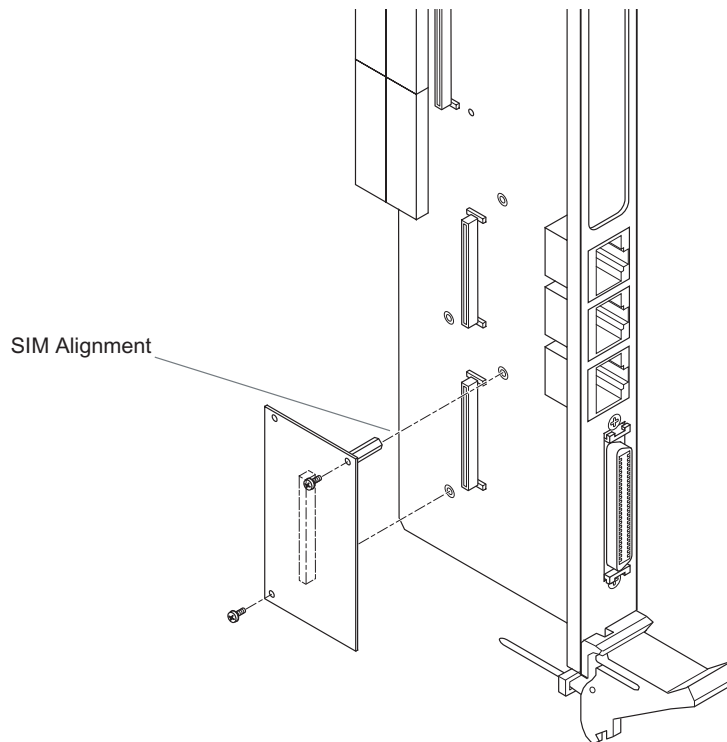

3. Gently press the top of the SIM to seat it on the transition module SIM connector. If the SIM does not seat with gentle pressure, recheck the alignment of the connectors. Do not force the SIM onto the transition module.
4. Secure the SIM to the transition module standoffs with the two Phillips-head screws provided. Do not over tighten the screws.

## 7.6 Installing the PIM

If a PIM has already been installed on the CPCI-6020-MCPTM-01, or you are installing a transition module as it has been shipped from the factory, disregard this section and proceed to [Installing and Removing the Transition Module](#).

### Procedure

For PIM installation, perform the following steps:

1. Attach an ESD strap to your wrist. Attach the other end of the ESD strap to the chassis as a ground. The ESD strap must be secured to your wrist and to ground throughout the procedure.
2. Perform an operating system shutdown. Turn the AC or DC power off and remove the AC cord or DC power lines from the system.
3. Remove chassis or system cover(s) as necessary for access to the CompactPCI.

### NOTICE

#### Product Damage

Inserting or removing modules in a non-hot swap chassis with the power applied may result in damage to the module components. The CPCI-6020-MCPTM-01 is not a hot swap board, but it may be installed in a hot swap chassis with power applied if the corresponding CPCI-6020 is removed from the front slot first.



### WARNING

#### Personal Injury or Death

Dangerous voltages, capable of causing death, are present in this equipment. Use extreme caution when handling, testing and adjusting.

4. Carefully remove the transition module from its CompactPCI card slot and lay it flat on a stable surface.
5. Remove the PIM filler from the front panel of the transition module.

- Slide the face plate (front bezel) of the PIM module into the front panel opening from behind and place the PIM module on top of the transition module, aligned with the appropriate two PIM connectors (P0 and P4). The two connectors on the underside of the PIM module should then connect smoothly with the corresponding connectors on the transition module (J10 and J14). Refer to the following figure for proper screw/board alignment.

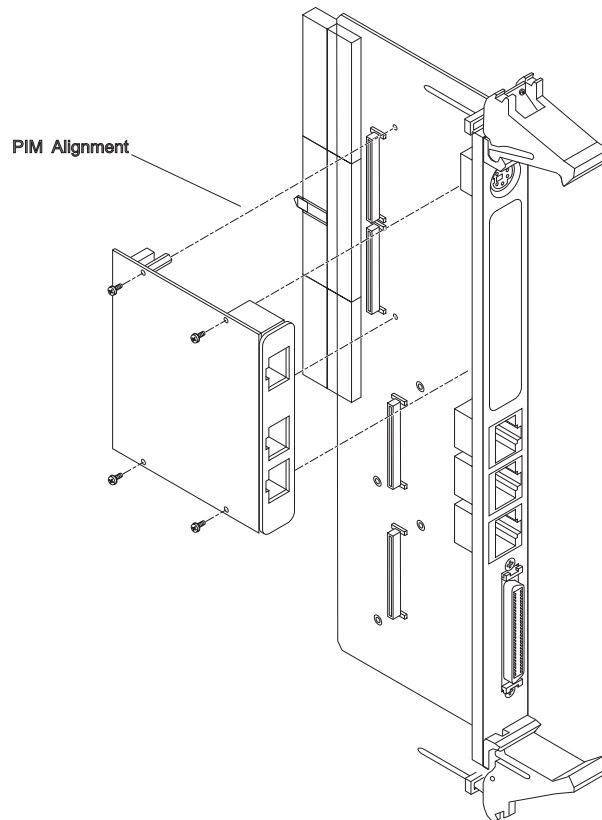

- Insert the four short Phillips screws, provided with the PIM, through the holes on the bottom side of the transition module into the PIM front bezel and rear standoffs. Tighten the screws.
- With the CPCI-6020-MCPTM-01 in the correct vertical position that matches the pin positioning of the backplane, carefully slide the transition module into the appropriate slot and seat tightly into the backplane.
- Secure in place with the screws provided, making good contact with the transverse mounting rails to minimize RF emissions.
- Replace the chassis or system cover(s), reconnect the system to the AC or DC power source and turn the equipment power on, or if hot swapping, you may now install the CPCI-6020.

## 7.7 Installing and Removing the Transition Module



### WARNING

#### Personal Injury or Death

Dangerous voltages, capable of causing death, are present in this equipment. Use extreme caution when handling, testing and adjusting.

### NOTICE

#### Product Damage

Avoid touching areas of integrated circuitry; static discharge can damage these circuits.

### Installation Procedure

After all peripheral modules have been installed and all of the appropriate jumpers have been set, you are ready to install the transition module in its chassis slot. At this point, follow the steps below:

1. Attach an ESD strap to your wrist. Attach the other end of the strap to the chassis as a ground. The ESD strap must be secured to your wrist and to ground throughout the procedure.
2. Perform an operating system shutdown. Turn the AC or DC power off and remove the AC cord or DC power lines from the system. Remove the chassis or system cover(s) as necessary for access to the chassis backplane.
3. With the CPCI-6020-MCPTM-01 in the correct vertical position that matches the pin positioning of the backplane, carefully slide the transition module into the appropriate slot and seat tightly into the backplane.
4. Secure in place with the screws provided, making good contact with the transverse mounting rails to minimize RF emissions.
5. Replace the chassis or system cover(s), reconnect the system to the AC or DC power source and turn the equipment power on, or if hot swapping, you may now install the CPCI-6020.

## Removal Procedure

Although the CPCI-6020 Single Board Computer can be removed and inserted while power is applied, the CPCI-6020-MCPTM-01 transition module is not hot swap capable. Inserting or removing the transition module while the CPU board is active may affect the normal operation of the CPU board. Even in a hot swap capable chassis, the CPU back end power should be switched off (or the chassis power shut down) prior to inserting or removing the corresponding transition module.

Follow these steps to remove the transition module from the rear chassis slot.

1. Remove the back-end power from the CPCI-6020 or power down the chassis.
2. Remove the system or chassis covers.
3. Loosen the screws that attach the transition module to the rear slot.
4. Push the ejector handles outward to the open position; this should disengage the connector from the backplane.
5. Using the handles, pull the module from the slot.

## 7.8 Connectors and Cables

The connectors on the CPCI-6020-MCPTM-01 transition module are listed in the next table. The port connectors are located on the front panel and the top side of the transition module, which is shown in [Figure 7-2](#). Refer to [Table 7-3 on page 142](#) for a list of the cables and [Connector Pin Assignments on page 143](#) for connector pinout information.

*Table 7-2 Rear Transition Module Connectors/Headers*

Type	Number	Description
COM3/COM4	J1	50-pin female connector
Ethernet Port 2	J2	Standard RJ-45 female connector
CompactPCI	J3/J4/J5	J3 is a 95-pin AMP Z-pack 2 mm hard metric type B connector, J4 is a 110-pin 2 mm hard metric type B connector.
Ethernet Port 1	J6	Standard RJ-45 female connector
Serial Port 1	J7	Standard RJ-45 female connector
Serial Port 2	J8	COM2 9-pin header
EIDE Interface	J9	40-pin header for secondary EIDE port
PIM Connector	J10/J14	Two 64-pin connectors for PMCIO (1 ground provided with each PMCIO signal)
Floppy Header	J11	34-pin header for floppy port
SIM Connector	J12/J13	Two 60-pin female connectors for SIMs
Keyboard/ Mouse Connector	J15	6-pin circular DIN for combined keyboard/mouse
Serial Port 3	J16	3-pin header for selection of DTE or DCE interface

Table 7-2 Rear Transition Module Connectors/Headers (continued)

Type	Number	Description
Serial Port 4	J17	3-pin header for selection of DTE or DCE interface
Floppy Power	J18	Stand-alone 4-pin power header for floppy
PLD JTAG	J19	8-pin programming header
COM1 Port	J20	3-pin header sets serial port 1 from PIM or CPCI-6020
Speaker Header	J21	For onboard speaker access.

Table 7-3 Rear Transition Module Cables

Part Number	Description
User-supplied	EIA-232-D DTE or DCE cable
User-supplied	20-conductor cable; usually supplied with the modem
User-supplied	6-conductor cable; usually supplied with the modem
Supplied with CPCI-6020-MCPTM-01	Keyboard/mouse Y-adapter cable (Motorola Part Number 30-W2309E01A)
User-supplied	40-line flat ribbon cable with 40-pin header connectors for EIDE drives
User-supplied	34-line flat ribbon cable with 34-pin header connectors for floppy drive
CA-8205E	Y-adapter cable, HD-50 male connector to two HD-26 female connectors.
User-supplied	2-line cable with 2-pin header connector for speaker
CA27 (requires: CA-8205E)	Straight-through adapter cable to attach a DB-25 male connector to an HD-26 female connector, 15 feet long. May be used for EIA-232-D applications
XR346HD26DB25-K	Straight-through adapter cable to attach a DB-25 female connector to an HD-26 male connector, 12 feet long

## 7.9 Connector Pin Assignments

The following tables summarize the pin assignments of RTM connectors that are specific to the CPCI-6020 modules configured for use with the CPCI-6020-MCPTM-01 transition module.

### 7.9.1 CompactPCI Connectors

Connector J3 is a 95-pin AMP Z-pack 2 mm hard metric type B connector. The pinouts for this connector are identical to those on the corresponding J3 connector on the CPCI-6020, and are described in [Chapter 3, Controls, LEDs, and Connectors](#).

Connector J4 is a 110-pin 2 mm hard metric type A connector. This connector is placed on the board for alignment only. The keying tabs on the type A connector assist with alignment of pins in the backplane connector during insertion of the boards. No signals are connected to J4 except the row F ground pins.

Connector J5 is a 110-pin AMP Z-pack 2 mm hard metric type B connector. This connector routes the I/O signals for the two COM ports, the EIDE secondary port, the keyboard, the mouse, the two USB ports (not implemented on the CPCI-6020-MCPTM-01, but related signals are routed to the host I/O connector of the PMC I/O interface) and the two Ethernet ports. The pinouts for this connector are identical to those on the corresponding J5 connector on the CPCI-6020, and are described in [Chapter 3, Controls, LEDs, and Connectors](#).

### 7.9.2 PMC I/O Module Connector

There is one pair of 64-pin SMT connectors on the CPCI-6020-MCPTM-01 transition module that provide an interface for one optional add-on PMC I/O module (PIM). On the host I/O connectors, a PMC I/O module would only use power, ground, and the OUT-going serial port pins. A host I/O module could potentially use all pins except the OUT-going serial port.

The pin assignments are as follows:

*Table 7-4 PMC I/O Module - Host I/O Connector Pin Assignments*

Pin	Signal	Signal	Pin
1	IN1_DCD	+12 V	2
3	IN1_RXD	IN1_TXD	4
5	+5 V	IN1_DTR	6
7	IN1_DSR	IN1_RTS	8
9	IN1_CTS	+3.3 V	10
11	IN1_RI	IN2_DCD	12
13	GND	IN2_RXD	14
15	IN2_TXD	IN2_DTR	16
17	IN2_DSR	GND	18
19	IN2_RTS	IN2_CTS	20

*Table 7-4 PMC I/O Module - Host I/O Connector Pin Assignments  
(continued)*

Pin	Signal	Signal	Pin
21	+5 V	IN2_RI	22
23	Reserved	Reserved	24
25	Reserved	+3.3 V	26
27	Reserved	Reserved	28
29	GND	Reserved	30
31	Reserved	Reserved	32
33	Reserved	GND	34
35	Reserved	Reserved	36
37	+5 V	Reserved	38
39	Reserved	Reserved	40
41	Reserved	+3.3 V	42
43	Reserved	UDATA0-	44
45	GND	UDATA0+	46
47	UVCC1	UVCC0	48
49	UDATA1+	GND	50
51	UDATA1-	OUT_RI	52
53	+5 V	OUT_DCD	54
55	OUT_DTR	OUT_DSR	56
57	OUT_CTS	+3.3 V	58
59	OUT_RTS	OUT_RXD	60
61	-12 V	OUT_TXD	62
63	I2C_CLK	I2C_DAT	64

On the PMC I/O Connector, pin meaning is defined entirely by the PMC residing on the host. A host I/O module would not use any pins on this connector.

*Table 7-5 PMC I/O Module - PMC I/O Connector Pin Assignments*

Pin	Signal	Signal	Pin
1	PMC IO1	PMC IO2	2
3	PMC IO3	PMC IO4	4
5	PMC IO5	PMC IO6	6
7	PMC IO7	PMC IO8	8
9	PMC IO9	PMC IO10	10
11	PMC IO11	PMC IO12	12
13	PMC IO13	PMC IO14	14



Table 7-5 PMC I/O Module - PMC I/O Connector Pin Assignments  
(continued)

Pin	Signal	Signal	Pin
15	PMC IO15	PMC IO16	16
17	PMC IO17	PMC IO18	18
19	PMC IO19	PMC IO20	20
21	PMC IO21	PMC IO22	22
23	PMC IO23	PMC IO24	24
25	PMC IO25	PMC IO26	26
27	PMC IO27	PMC IO28	28
29	PMC IO29	PMC IO30	30
31	PMC IO31	PMC IO32	32
33	PMC IO33	PMC IO34	34
35	PMC IO35	PMC IO36	36
37	PMC IO37	PMC IO38	38
39	PMC IO39	PMC IO40	40
41	PMC IO41	PMC IO42	42
43	PMC IO43	PMC IO44	44
45	PMC IO45	PMC IO46	46
47	PMC IO47	PMC IO48	48
49	PMC IO49	PMC IO50	50
51	PMC IO51	PMC IO52	52
53	PMC IO53	PMC IO54	54
55	PMC IO55	PMC IO56	56
57	PMC IO57	PMC IO58	58
59	PMC IO59	PMC IO60	60
61	PMC IO61	PMC IO62	62
63	PMC IO63	PMC IO64	64

### 7.9.3 10BaseT/100BaseTx Connectors

Two 10BaseT/100BaseTx RJ-45 connectors are located on the rear panel of the CPCI-6020-MCPTM-01 to support Ethernet I/O from the CPCI-6020. One channel is always routed from the CPCI-6020, the other is a custom-build option. Enabling this option requires that the proper zero ohm resistors be installed on the CPCI-6020. The pin assignments for these connectors are as follows:

*Table 7-6 10BaseT/100BaseTx Connector Pin Assignments*

Pin	Signal
1	TD+
2	TD-
3	RD+
4	AC Terminated
5	AC Terminated
6	RD-
7	AC Terminated
8	AC Terminated

### 7.9.4 COM1 Connector

An RJ-45 connector is located on the panel of the CPCI-6020-MCPTM-01 to provide the interface to the COM1 serial port. This port is configured as DCE. The pin assignments for this connector are as follows:

*Table 7-7 COM1 Connector Pin Assignments*

Pin	Signal
1	DCD
2	RTS
3	GND
4	TXD
5	RXD
6	GND
7	CTS
8	DTR

## 7.9.5 COM2 Header

One 9-pin planar header is located on the CPCI-6020-MCPTM-01 to provide the interface to the COM2 serial port. This port can be configured as either DCE or DTE. The pin assignments for this header are as follows:

Table 7-8 COM2 Header Pin Assignments

Pin	Signal	Signal	Pin
1	DCD	DSR	2
3	RXD	RTS	4
5	TXD	CTS	6
7	DTR	RI	8
9	GND	VOID (Key)	10

## 7.9.6 EIDE Header

One 40-pin planar header is located on the CPCI-6020-MCPTM-01 to provide the interface to the secondary EIDE port. The pin assignments for this header are as follows:

Table 7-9 EIDE Header Pin Assignments

Pin	Signal	Signal	Pin
1	DRESET_L	GND	2
3	DD7	DD8	4
5	DD6	DD9	6
7	DD5	DD10	8
9	DD4	DD11	10
11	DD3	DD12	12
13	DD2	DD13	14
15	DD1	DD14	16
17	DD0	DD15	18
19	GND	No Connect	20
21	DMARQ	GND	22
23	DIOW_L	GND	24
25	DIOR_L	GND	26
27	IORDY	No Connect	28
29	DMACK_L	GND	30
31	INTRQ	No Connect	32
33	DA1	No Connect	34
35	DA0	DA2	36
37	CS1FX_L	CS3FX_L	38

Table 7-9 EIDE Header Pin Assignments (continued)

Pin	Signal	Signal	Pin
39	No Connect	GND	40

## 7.9.7 Floppy Port Header

The CPCI-6020-MCPTM-01 provides a 34-pin header to interface to a floppy disk drive. The pin assignments and signal mnemonics for this connector are listed below.

Table 7-10 Floppy Header Pin Assignments

Pin	Signal	Signal	Pin
1	GND	No Connect	2
3	GND	No Connect	4
5	GND	No Connect	6
7	No Connect	INDEX_L	8
9	GND	MTR0_L	10
11	GND	DS1_L	12
13	No Connect	DS0_L	14
15	GND	MTR1_L	16
17	No Connect	DIR_L	18
19	GND	STEP_L	20
21	GND	WDATA_L	22
23	GND	WGATE_L	24
25	GND	TR0_L	26
27	GND	WPROT_L	28
29	GND	RDATA_L	30
31	GND	HDSEL_L	32

## 7.9.8 +5VDC Power Connector

The CPCI-6020-MCPTM-01 has a 4-pin header that can be used to provide +5VDC power to off-board devices. This power is derived from the fused +5VDC power on the CPCI-6020-MCPTM-01. Any external device powered from this connector must draw no more than 200mA. The pin assignments are listed in the following table.

Table 7-11 +5Vdc Power Connector

Pin	Signal
1	+5 VDC Fused
2	GND
3	GND

Table 7-11 +5Vdc Power Connector (continued)

Pin	Signal
4	No Connect

### 7.9.9 Keyboard/Mouse Connector

The keyboard/mouse interface is provided by a 6-pin circular DIN connector. To use the keyboard function only, a keyboard may be connected directly to this connector. To use both the keyboard and the mouse functions, use the Y-adaptor cable provided with the CPCI-6020-MCPTM-01. Refer to the following table for pin assignments.

Table 7-12 Keyboard/Mouse Connector Pin Assignments

Pin	Signal
1	KBD DAT
2	MS DAT
3	GND
4	+5 VDC Fused
5	KBD CLK
6	MS CLK

### 7.9.10 Sync/Async Serial Ports

The interface for the sync/async serial ports COM3 and COM4 is provided by a 50-pin female connector. The connector shield for the port is tied to chassis ground. The pin assignments and signal mnemonics are listed in the following table.

Pin assignments for this connector change depending on which SIM is plugged into the connector.

Table 7-13 Sync/Async Serial Connector Pin Assignments

Pin	Signal	Signal	Pin
1	TXD3	TXD4	26
2	RXD3	RXD4	27
3	RTS3	RTS4	28
4	CTS3	CTS4	29
5	DSR3	DSR4	30
6	GND	GND	31
7	DCD3	DCD4	32
8	SP3_P9	SP4_P9	33
9	SP3_P10	SP4_P10	34
10	SP3_P11	SP4_P11	35

Table 7-13 Sync/Async Serial Connector Pin Assignments (continued)

Pin	Signal	Signal	Pin
11	SP3_P12	SP4_P12	36
12	SP3_P13	SP4_P13	37
13	SP3_P14	SP4_P14	38
14	TXCI3	TXCI4	39
15	SP3_P16	SP4_P16	40
16	RXCI3	RXCI4	41
17	LLB3	LLB4	42
18	SP3_P19	SP4_P19	43
19	DTR3	DTR4	44
20	RLB3	RLB4	45
21	RI3	RI4	46
22	SP3_P23	SP4_P23	47
23	TXCO3	TXCO4	48
24	TM3	TM4	49
25	SP3_P26	SP4_P26	50

### 7.9.11 Speaker Output Header

The 2-pin header provides connection to an external speaker. The pin assignments are listed in the following table.

Table 7-14 Speaker Output Connector Pin Assignments

Pin	Signal
1	GND
2	SPKROC_L

## 8.1 Overview

You can use the factory-installed debug monitor, PPCBug, to modify certain parameters contained in the board's Non-Volatile RAM (NVRAM), also known as Battery Backed-up RAM (BBRAM).

- The Board Information Block in NVRAM contains various elements concerning operating parameters of the hardware. Use the PPCBug command CNFG to change those parameters.
- Use the PPCBug command ENV to change configured PPCBug parameters in NVRAM.

The CNFG and ENV commands are both described in the *PPCBug Firmware Package User's Manual*. Refer to that manual for general information about their use and capabilities.

The following paragraphs present additional information about CNFG and ENV that is specific to the PPCBug debugger, along with the parameters that can be configured with the ENV command.

## 8.2 CNFG - Configure Board Information

Use this command to display and configure the Board Information Block, which is stored in the NVRAM. The Board Information Block lists details of your specific board, such as the Board Serial Number, the Board Identifier, the Bus Clock Speed and other operational or ID characteristics. The example below displays a typical Board Information Block:

<b>Detail</b>	<b>Value</b>
Board (PWA) Serial Number	= "2717994"
Board Identifier	= "CPCI-6020-60X-0XX"
Artwork (PWA) Identifier	= "01-W3938F02B"
MPU Clock Speed	= "500"
Bus Clock Speed	= "067"
Ethernet Address	= \$0001AF0A1B2C
Local SCSI Identifier*	= "07"
System Serial Number	= "1234567"
System Identifier	= "Motorola CPCI-6020603-001a"
License Identifier	= "12345678 "

The value or identifier to the right of the equal sign is displayed as left-justified character (ASCII) strings padded with space characters, and quotes (") are displayed to indicate the size of the string. Values that are not in quotes are considered data strings, and data strings are right-justified. The data strings are padded with zeroes if the length is not met.



**The CPCI-6020 has no local SCSI Bus controller, hence, the Local SCSI Identifier parameter is ignored by the PPCBug.**

The Board Information Block is factory-configured before shipment. There is no need to modify block parameters unless the NVRAM is corrupted. Refer to the *CPCI-6020 CompactPCI Single Board Computer Programmer's Reference Guide* for the actual location and other information about the Board Information Block. Refer to the *PPCBug Firmware Package User's Manual* for a description of CNFG and examples.

## 8.3 ENV - Set Environment

Use the ENV command to view and/or configure interactively all PPCBug operational parameters that are kept in Non-Volatile RAM (NVRAM). Refer to the *PPCBug Firmware Package User's Manual* for a description of the use of ENV.

Listed and described next are the parameters that you can configure using ENV. The default values shown were those in effect when this publication went to print.

## 8.4 Configuring the PPCBug Parameters

You can configure the PPCBug parameters using ENV command with the following arguments:

```
Bug, AST, or System environment [B/A/S] = B?
```

- |   |  |
|---|--|
| B | Bug is the mode where no system type of support is displayed. However, system-related items are still available. (Default).                                  |
| A | Abbreviated Self-Test  |
| S | System is the standard mode of operation, and is the default mode if NVRAM should fail. System mode is defined in the PPCBug Firmware Package User's Manual. |

```
Maximum Memory Usage (Mb, 0=AUTO) = 2?
```

The maximum amount of DRAM that PPCBug is allowed to allocate for its own purposes.



Field Service Menu Enable [Y/N] = N?

- Y Display the field service menu.
- N Do not display the field service menu. (Default)

Probe System for Supported I/O Controllers [Y/N] = Y?

- Y Accesses will be made to the appropriate system busses (e.g., VMEbus, local MPU Bus) to determine the presence of supported controllers. (Default)
- N Accesses will not be made to the VMEbus to determine the presence of supported controllers.

Auto-Initialize of NVRAM Header Enable [Y/N] = Y?

- Y NVRAM (Prep partition) header space is initialized automatically during board initialization, but only if the PReP partition fails a sanity check. (Default)
- N NVRAM header space will not be initialized automatically during board initialization.

Network PReP-Boot Mode Enable [Y/N] = N?

- Y Enable PReP-style network booting (same boot image from a network interface as from a mass storage device.)
- N Do not enable PReP-style network booting. (Default)

SCSI Bus Reset on Debugger Startup [Y/N] = N?

- Y SCSI Bus is reset on debugger setup.
- N SCSI Bus is not reset on debugger setup (Default)

Primary SCSI Bus Negotiations Type [A/S/N] = A?

- Y Asynchronous SCSI Bus negotiation. (Default)
- S Synchronous SCSI Bus negotiation.
- N None

Primary SCSI Data Bus Width [W/N] = N?

- W Wide SCSI (16-bit bus)
- N Narrow SCSI (8-bit bus). (Default)

Secondary SCSI Identifier = "07"?

If the board has a secondary SCSI controller, this number is the secondary SCSI ID or address. For the CPCI-6020, all PCI add-on SCSI controllers/adapters supported by PPCBug are set to the SCSI ID value entered here.

NVRAM Bootlist (GEV.fw-boot-path) Boot Enable [Y/N] = N?

Y Give boot priority to devices defined in the fw-boot-path global environment variable (GEV).

N Do not give boot priority to devices listed in the fw-boot-path GEV. (Default)

When enabled, the GEV (Global Environment Variable) boot takes priority over all other boots, including Autoboot and Network Boot.

NVRAM Bootlist(GEV.fw-boot-path) Boot at power-up only [Y/N]=N?

Y Give boot priority to devices defined in the fw-boot-path GEV at power-up reset only.

N Give power-up boot priority to devices listed in the fw-boot-path GEV at any reset. (Default)

NVRAM Bootlist (GEV.fw-boot-path) Boot Abort Delay = 5?

The time in seconds that a boot from the NVRAM boot list will delay before starting the boot. The purpose for the delay is to allow you the option of stopping the boot by use of the BREAK key. The time value is from 0-255 seconds. (Default = 5 seconds)

Auto Boot Enable [Y/N] = N?

Y The Autoboot function is enabled.

N The Autoboot function is disabled. (Default)

Auto Boot at power-up only [Y/N] = N?

Y Autoboot is attempted at power-up reset only.

N Autoboot is attempted at any reset. (Default)

Auto Boot Scan Enable [Y/N] = Y?

Y If Autoboot is enabled, the Autoboot process attempts to boot from devices specified in the scan list (e.g., FDISK/CDROM/TAPE/HDISK). (Default)

N If Autoboot is enabled, the Autoboot process uses the Controller LUN and Device LUN to boot.

Auto Boot Scan Device Type List = FDISK/CDROM/TAPE/HDISK?

This is the listing of boot devices displayed if the Autoboot Scan option is enabled. If you modify the list, follow the format shown above (uppercase letters, using forward slash as separator).

Auto Boot Controller LUN = 00?

Refer to the *PPCBug Firmware Package User's Manual* for a listing of disk/tape controller modules currently supported by PPCBug. (Default = \$00)

Auto Boot Device LUN = 00?

Auto Boot Partition Number = 00?

Which disk "partition" is to be booted, as specified in the PowerPC Reference Platform (PRP) specification. If set to zero, the firmware will search the partitions in order (1, 2, 3, 4) until it finds the first "bootable" partition. That is then the partition that will be booted. Other acceptable values are 1, 2, 3 or 4. In these four cases, the partition specified will be booted without searching.

Auto Boot Abort Delay = 7?

The time in seconds that the Autoboot sequence will delay before starting the boot. The purpose for the delay is to allow you the option of stopping the boot by use of the BREAK key. The time value is from 0-255 seconds. (Default = 7 seconds)

Auto Boot Default String [NULL for an empty string] =?

You may specify a string (filename) which is passed on to the code being booted. The maximum length of this string is 16 characters. (Default = null string)

ROM Boot Enable [Y/N] = N?

Y                    The ROMboot function is enabled.

N                    The ROMboot function is disabled. (Default)

ROM Boot at power-up only [Y/N] = Y?

Y                    ROMboot is attempted at power-up only. (Default)

N                    ROMboot is attempted at any reset.

ROM Boot Abort Delay = 5?

The time in seconds that the ROMboot sequence will delay before starting the boot. The purpose for the delay is to allow you the option of stopping the boot by use of the BREAK key. The time value is from 0-255 seconds. (Default = 5 seconds)

ROM Boot Direct Starting Address = FFF000000?

The first location tested when PPCBug searches for a ROMboot module. (Default = \$FFF00000)

ROM Boot Direct Ending Address = FFFFFFFFC?

The last location tested when PPCBug searches for a ROMboot module. (Default = \$FFFFFFFC)

Network Auto Boot Enable [Y/N] = N?

Y                    The Network Auto Boot (NETboot) function is enabled.

N                    The NETboot function is disabled. (Default)

Network Auto Boot at power-up only [Y/N] = N?

Y                    NETboot is attempted at power-up reset only.

N                    NETboot is attempted at any reset. (Default)

Network Auto Boot Controller LUN = 00?

Refer to the *PPCBug Firmware Package User's Manual* for a listing of network controller modules currently supported by PPCBug. (Default = \$00)

Network Auto Boot Failover Controller LUN = 00?

If set to zero (\$00), there will be a second attempt at network boot using the failover Ethernet controller. If set to non-zero, an attempt is made to use this device to download the same information that was to be downloaded using the primary Ethernet controller. The failover takes place when the primary reports a hard error. Refer to the *PPCBug Firmware Package User's Manual* for a listing of network controller modules currently supported by the PPCBug.

Network Auto Boot Device LUN = 00?

Refer to the *PPCBug Firmware Package User's Manual* for a listing of network controller modules currently supported by PPCBug. (Default = \$00)

Network Auto Boot Abort Delay = 5?

The time in seconds that the NETboot sequence will delay before starting the boot. The purpose for the delay is to allow you the option of stopping the boot by use of the **BREAK** key. The time value is from 0-255 seconds. (Default = 5 seconds)

Network Auto Boot Configuration Parameters Offset (NVRAM) = 00001000?

The address where the network interface configuration parameters are to be saved/retained in NVRAM; these parameters are the necessary parameters to perform an unattended network boot. A typical offset might be \$1000, but this value is application-specific. (Default = \$00001000)

## NOTICE

### Data Loss

**If you use the NIOT debugger command, these parameters need to be saved somewhere in the offset range \$00001000 through \$000016F7. The NIOT parameters do not exceed 128 bytes in size. The setting of this ENV pointer determines their location. If you have used the same space for your own program information or commands, they will be overwritten and lost.**

**You can relocate the network interface configuration parameters in this space by using the ENV command to change the Network Auto Boot Configuration Parameters Offset from its default of \$00001000 to the value you need to be clear of your data within NVRAM.**

Watchdog prior status ignored at Autoboot [Y/N] = Y?

Y                   Autoboot normally, regardless of prior Watchdog expiration.

N                   Abort Autoboot if Watchdog has previously expired

Watchdog reset at board reset [Y/N] = N?

Y                   Level 2 Watchdog timer turned off during startup.

N                   Level 2 Watchdog timer status (running or reset) unchanged by startup

Watchdog shutdown at board reset [Y/N] = N?

Y                   Disable RTC Watchdog during startup.

N                   Do not disable RTC Watchdog during startup

Reset Ethernet chip after file transfer [Y/N] = N?

Y                   Reset Ethernet chip after transfer.

N                   Do not reset Ethernet chip after transfer.

Stop Auto Boot after selftest failure [Y/N] = N?

- Y                If selftest fails do not autoboot.
- N                Selftest results do not affect autoboot process.

Memory Size Enable [Y/N] = Y?

- Y                Memory will be sized for Self Test diagnostics.
- N                Memory will not be sized for Self Test diagnostics.

Memory Size Starting Address = 00000000?

The default Starting Address is \$00000000.

Memory Size Ending Address = 70000000?

The default Ending Address is the calculated size of local memory. If the memory start is changed from \$00000000, this value will also need to be adjusted.

DRAM Speed in NANO Seconds = 10?

The default setting for this parameter will vary depending on the speed of the DRAM memory parts installed on the board. The default is set to the slowest speed found on the available banks of DRAM memory.

ROM Bank A Access Speed (ns) = 150?

This is the access speed in nanoseconds of the device.

ROM Bank B Access Speed (ns) = 120?

This is the access speed in nanoseconds of the device.

DRAM Parity Enable [On-Detection/Always/Never - O/A/N] = 0?

- O                DRAM parity is enabled upon detection. (Default)
- A                DRAM parity is always enabled.
- N                DRAM parity is never enabled.

The parameter (above) also applies to enabling ECC for DRAM.

L2 Cache Parity Enable [On-Detection/Always/Never - O/A/N] = 0

- O                L2 Cache parity is enabled upon detection. (Default)
- A                L2 Cache parity is always enabled.
- N                L2 Cache parity is never enabled.

```
PCI Interrupts Route Control Registers (PIRQ0/1/2/3) = 0A050900
```

Initializes the PIRQx (PCI Interrupts) route control registers in the IBC (PCI/ISA Bus bridge controller). The ENV parameter is a 32-bit value that is divided by 4 to yield the values for route control registers PIRQ0/1/2/3. The default is determined by system type. For details on PCI/ISA interrupt assignments and for suggested values to enter for this parameter, refer to the 8259 Interrupts section in the *CPCI-6020CPCI-6020 CompactPCI Single Board Computer Programmer's Reference Guide*.

```
Serial Startup Code Master Enable [Y/N] = N?
```

The Serial Startup Codes can be displayed at key points in the initialization of the hardware devices. Should the debugger fail to come up to a prompt, the last code displayed will indicate how far the initialization sequence had progressed before stalling. The codes are enabled by an ENV parameter.

```
Serial Startup Code LF Enable [Y/N] = N?
```

A line feed can be inserted after each code is displayed to prevent it from being overwritten by the next code. This is also enabled by an ENV parameter.

A list of LED/serial codes is included in the section on MPU, Hardware and Firmware Initialization in *Chapter 1 of the PPCBug Firmware Package User's Manual, Part 1*.

A means to execute user selectable BUG commands upon BUG startup has been added to the ENV parameters. The usage is as follows:

```
Firmware Command Buffer Enable [Y/N] = N?
```

- Y                    Enables the Firmware Command Buffer execution.
- N                    Disables the Firmware Command Buffer execution (Default)

```
Firmware Command Buffer Delay = 5?
```

Defines the number of seconds to wait before firmware begins executing the startup commands in the startup command buffer. During this delay, you may press any key to prevent the execution of the startup command buffer.

The default value of this parameter causes a startup delay of 5 seconds.

```
Firmware Command Buffer ['NULL' terminates entry]?
```

The Firmware Command Buffer contents contain the BUG commands which are executed upon firmware startup. BUG commands you will place into the command buffer should be typed just as you enter the commands from the command line. The string `NULL` on a new line terminates the command line entries. All BUG commands except for the following may be used within the command buffer: DU, ECHO, LO, TA, VE.



**Interactive editing of the startup command buffer is not supported. If changes are needed to an existing set of startup commands, a new set of commands with changes must be reentered.**





## A.1 Embedded Communications Computing Documents

The Motorola publications listed below are referenced in this manual, or apply to systems that use this product. You can obtain electronic copies of Embedded Communications Computing publications by:

- Contacting your local Motorola sales office, or
- Visiting Motorola Embedded Communications Computing Groups's World Wide Web literature site, <http://www.motorola.com/computer/literature>.

*Table A-1 Embedded Communications Computing Documents*

Document Title	Publication Number
CPCI-6020 CompactPCI Single Board Computer Programmer's Reference	6806800E73
Harrier ASIC Programmer's Reference Guide	ASICHRA/PG
PPCBUG Firmware Package User's Manual (Parts 1 and 2)	PPCBUGA1/UM PPCBUGA2/UM
PPCBUG Diagnostics Manual	PPCDIAA/UM

To obtain the most up-to-date product information in PDF format, visit our web site at <http://www.motorola.com/computer/literature>.

## A.2 Manufacturers' Documents

For specific component or software information, refer to the following table for manufacturers' data sheets or users' manuals. As an additional help, a source for the listed document is also provided. Please note that in many cases, the information is preliminary and the revision levels of the documents are subject to change without notice.

*Table A-2 Manufacturers' Documents*

Document Title and Source	Publication Number or Search Term
Freescale Semiconductor	<a href="http://www.freescale.com">http://www.freescale.com</a>
Freescale MPC7410TM RISC Microprocessor Technical Summary	MPC7410TS/D

Table A-2 Manufacturers' Documents (continued)

Document Title and Source	Publication Number or Search Term
MPC7410 RISC Microprocessor User's Manual PowerPC Microprocessor Family: The Programming Environments PowerPC Microprocessor Common Hardware Reference Platform: A System Architecture (CHRP), Version 1.0 OR IBM Microelectronics <a href="http://www.ibm.com/">http://www.ibm.com/</a>	MPC7410UM/D MPCFPE/AD TB338/D  MPRPPCFPE-01
<a href="http://www.atmel.com">Atmel Corporation</a>	<a href="http://www.atmel.com">http://www.atmel.com</a>
ATMEL Nonvolatile Memory Data Book	AT24C04
<a href="http://www.intel.com">Intel Corporation</a>	<a href="http://www.intel.com">http://www.intel.com</a>
GD82551IT Ethernet Controller	82551IT.pdf
21143 PCI/Card Bus LAN Controller	21143.htm
21154 PCI-to-PCI Bridge	21554.htm
1.8 Volt StrataFlash Memory	1.8 V StrataFlash Memory
<a href="http://www.st.com/stonline">STMicroelectronics</a>	<a href="http://www.st.com/stonline">http://www.st.com/stonline</a>
48T37V CMOS 8K x 8 TIMEKEEPERTM SRAM Data Sheet	48T37V
<a href="http://www.winbond.com">Winbond Electronics Corporation</a>	<a href="http://www.winbond.com">http://www.winbond.com</a>
PC97317-ICL/VUL (Super I/OTM Enhanced Sidewinder Lite) Floppy Disk Controller, Keyboard Controller, Real-Time Clock, Dual UARTs, IEEE 1284 Parallel Port and IDE Interface	PC97317-ICL/VUL
W83C554x Enhanced System I/O Controller with PCI Arbiter (PIB)	2554; Rev C.1.0b
<a href="http://www.ti.com">Texas Instruments</a>	<a href="http://www.ti.com">http://www.ti.com</a>
Texas Instruments TI16C550C Asynchronous Communications Element (ACE) - Data Sheet	SLLS177E March 1994, Revised April 1998

## A.3 Related Specifications

For additional information, refer to the following table for related specifications. Please note that in many cases, the information is preliminary and the revision levels of the documents are subject to change without notice.

Table A-3 Related Specifications

Document Title and Source	Publication Number or Search Term
IEEE Institute of Electrical and Electronics Engineers, Inc. <a href="http://standards.ieee.org">http://standards.ieee.org</a>	
IEEE - Common Mezzanine Card Specification (CMC)	P1386 Draft 2.0

Table A-3 Related Specifications (continued)

Document Title and Source	Publication Number or Search Term
IEEE - PCI Mezzanine Card Specification (PMC)	P1386.1 Draft 2.0
IEEE Standard for Local Area Networks: Carrier Sense Multiple Access with Collision Detection (CSMA/CD) Access Method and Physical Layer Specifications	IEEE 802.3
PCI Special Interest Group (PCI SIG) <a href="http://www.pcisig.com/">http://www.pcisig.com/</a>	
Peripheral Component Interconnect (PCI) Local Bus Specification, Revision 2.0, 2.1, 2.2	PCI Local Bus Specification
IBM for Specifications <a href="http://www.ibm.com">http://www.ibm.com</a>	
PowerPC Reference Platform (PRP) Specification, Third Edition, Version 1.0, Volumes I and II	MPR-PPC-RPU-02 Power PC Specification
Electronic Industries Alliance <a href="http://www.eia.org">http://www.eia.org</a>	
Interface Between Data Terminal Equipment and Data Circuit-Terminating Equipment Employing Serial Binary Data Interchange	TIA/EIA-232 Standard
Information Technology - Local and Metropolitan Networks - Part 3: Carrier Sense Multiple Access with Collision Detection (CSMA/CD) Access Method and Physical Layer Specifications Global Engineering Documents <a href="http://global.ihs.com/index.cfm">http://global.ihs.com/index.cfm</a> for publications (This document can also be obtained through the national standards body of member countries.)	ISO/IEC 8802-3
ANSI Small Computer System Interface-2 (SCSI-2), Draft Document Global Engineering Documents <a href="http://global.ihs.com/index.cfm">http://global.ihs.com/index.cfm</a> for publications	X3.131.1990
PowerPC Microprocessor Common Hardware Reference Platform: A System Architecture (CHRP), Version 1.0 WebSite: <a href="http://www.freescale.com/webapp/sps/library/prod_lib.jsp">http://www.freescale.com/webapp/sps/library/prod_lib.jsp</a> OR Morgan Kaufmann Publishers, Inc. Telephone: (415) 392-2665 Telephone: 1-800-745-7323 <a href="http://books.elsevier.com">http://books.elsevier.com</a>	ISBN 1-55860-394-8
PCI Industrial Manufacturers Group (PICMG) <a href="http://www.picmg.com">http://www.picmg.com</a>	
Compact PCI Specification  PCI-to-PCI Bridge Specification PCI-ISA Specification CompactPCI Hot Swap Specification (Draft)	CPCI Rev. 2.1 Dated 9/2/97 Rev. 1.02 Rev. 2.0 PICMG 2.1 DO.91 Dated 2/5/98



## Symbols

+5Vdc power connector (CPCI-6020-MCPTM-01) 148

## A

accessing PPCBug 110

## B

Board Information Block (BIB), changing 152

Board Information Block, PPCBug 151

bridges (21154) as interface 83

bridges, description 81

buffers, primary/secondary bus 83

buses, (PCI) described 83

## C

checksum, affects on PPCBug 108

CNFG, use 151

COM1 connector (CPCI-6020-MCPTM-01) 146

COM2 header (CPCI-6020-MCPTM-01) 147

command list, PPCBug 110

CompactPCI

interface connectors 60

CompactPCI bus remote expansion 83

CompactPCI connectors (J3-J5) 143

CompactPCI interface capacity 83

compliances 32

connector

for I/O routing 63

for I/O routing, MCPN750A 64

CPCI-6020 description 81

CPCI-6020 features 31

CPCI-6020-MCPTM-01

cables 142

connector/header list 141

installation 140

PIM installation 138

PIM pin assignments 143

removing in hot swap chassis 141

SIM installation 136

SIMs 132

## D

damage reporting 36, 131

debugger commands 110, 111

diagnostic test groups 115

disposal of product 33, 36, 131

## E

EIDE header (CPCI-6020-MCPTM-01) 147

EIDE routing 84

EMC requirements 32

## ENV

configure PPCBug parameters 152

using 151

when to use 152

## ENV parameter

Auto Boot Abort Delay 155

Auto Boot at power-up only 154

Auto Boot Controller LUN 155

Auto Boot Default String 155

Auto Boot Device LUN 155

Auto Boot Enable 154

Auto Boot Partition Number 155

Auto Boot Scan Device Type List 154

Auto Boot Scan Enable 154

Auto-Initialize of NVRAM Header Enable 153

Bug, AST, or System mode 152

DRAM Parity Enable 158

DRAM Speed in NANO Seconds 158

Field Service Menu Enable 153

Firmware Command Buffer 159

Firmware Command Buffer Delay 159

Firmware Command Buffer Enable 159

L2 Cache Parity Enable 158

Memory Size Enable 158

Memory Size Ending Address 158

Memory Size Starting Address 158

Network Auto Boot Abort Delay 156

Network Auto Boot at power-up only 156

Network Auto Boot Configuration Parameters

Offset 156

Network Auto Boot Controller LUN 156

Network Auto Boot Device LUN 156

Network Auto Boot Enable 156

Network Auto Boot Failover Controller LUN 156

Network PReP-Boot Mode Enable 153

NVRAM Bootlist Boot Abort Delay 154

NVRAM Bootlist Boot at power-up only 154

NVRAM Bootlist Boot Enable 154

PCI Interrupts Route Control Registers 159

Primary SCSI Bus Negotiations Type 153

Primary SCSI Data Bus Width 153

Probe System for Supported I/O Controllers 153

Reset Ethernet chip after file transfer 157

ROM Bank A Access Speed 158

ROM Bank B Access Speed 158

ROM Boot Abort Delay 155

ROM Boot at power-up 155

ROM Boot Direct Ending Address 155

ROM Boot Direct Starting Address 155

ROM Boot Enable 155

SCSI Bus Reset 153

---

- Secondary SCSI Identified [153](#)
- Serial Startup Code LF Enable [159](#)
- Serial Startup Code Master Enable [159](#)
- Stop Auto Boot after selftest failure [158](#)
- Watchdog prior status ignored at Autoboot [157](#)
- Watchdog reset at board reset [157](#)
- Watchdog shutdown at board reset [157](#)
- environmental requirements [32](#), [35](#), [131](#)
- ESD precautions [47](#)
- Ethernet channel, primary [83](#)
- Ethernet connector (CPCI-6020-MCPTM-01) [146](#)

## F

- features (CPCI-6020) [31](#)
- firmware
  - PPCBug commands [111](#)
  - PPCBug components [107](#)
  - PPCBug diagnostic test groups [115](#)
  - PPCBug diagnostics purpose [114](#)
  - PPCBug initialization process [108](#)
  - PPCBug uses [107](#)
  - PPCBug's operational characteristics [108](#)
- floppy port header (CPCI-6020-MCPTM-01) [148](#)
- front/rear panel I/O [37](#)

## H

- Harrier A PPC arbiter [90](#)
- Harrier B resources [85](#)
- host bridges, description [81](#)

## I

- I/O description [37](#)
- initialization process PPCBug [108](#)
- inspecting shipment [35](#), [131](#)
- installation,RTM [140](#)
- ISA bridge/EIDE function [84](#)
- ISA bus resources [84](#)

## J

- J16/J17 headers on RTM [133](#)
- J17 connector on SBC [75](#)
- J3 connector on SBC [63](#), [64](#)

## K

- keyboard/mouse connector (CPCI-6020-MCPTM-01) [149](#)

## L

- local PCI buses described [83](#)

## M

- manufacturers' documents [161](#)
- memory block size, RAM500 [117](#)
- memory requirements, PPCBug [108](#)
- memory size from PPCBug [157](#)
- memory, size from PPCBug [157](#)
- MPU
  - processor bus [75](#)

## O

- ordering product [33](#)

## P

- parameters, configure PPCBug [152](#)
- PBC EIDE interface [84](#)
- PCI Bus A resources [83](#)
- PCI Bus B [85](#)
- PCI Bus B resources [85](#)
- PCI buses [83](#)
- PIM installation [138](#)
- pin assignments
  - +5Vdc power connector (CPCI-6020-MCPTM-01) [148](#)
  - COM1 connector (CPCI-6020-MCPTM-01) [146](#)
  - COM2 header (CPCI-6020-MCPTM-01) [147](#)
  - CPCI-6020-MCPTM-01 PIM connector [143](#)
  - EIDE header (CPCI-6020-MCPTM-01) [147](#)
  - Ethernet connector (CPCI-6020-MCPTM-01) [146](#)
  - floppy port header (CPCI-6020-MCPTM-01) [148](#)
  - keyboard/mouse connector [149](#)
  - RAM500 memory expansion connector [123](#)
  - speaker output header (CPCI-6020-MCPTM-01) [150](#)
  - sync/async serial ports (CPCI-6020-MCPTM-01) [149](#)
- pinouts
  - J1, CompactPCI Bus Connector [60](#)
  - J2, CompactPCI Bus Connector [61](#)
  - J3, CompactPCI User I/O Connector [63](#), [64](#)
  - J5, CompactPCI User I/O Connector [65](#)
  - J17 (debug connector not populated) [75](#)
- PLD, using with serial ports [84](#)
- PMC I/O Module (PIM) connector, RTM [143](#)
- ports, serial (synchronous) [84](#)
- power connector, RTM [148](#)
- power requirements [35](#), [131](#)
- PPCBug
  - access commands [110](#)
  - as command-driven [108](#)
  - components [107](#)
  - configuring parameters [152](#)
  - correcting command entries [110](#)
  - debugger commands [111](#)
  - diagnostic test groups [115](#)
  - diagnostic tests purpose [114](#)
  - ENV command explained [151](#)
  - list of commands [110](#)
  - memory [108](#)
  - risk reprogramming flash [114](#)
  - switching between directories [108](#), [114](#)
  - uses [107](#)
  - where used [107](#)
- PPCBug command, CNFG [151](#)
- PPCBug initialization process [108](#)
- PPCBug, affects of checksum [108](#)
- product, how to order [33](#)

---

## R

### RAM500

- as memory requirement for CPCI-6020 [117](#)
- bottom side connector (P1) [120](#)
- bottom side connector pin outs (P1) [120](#)
- description [117](#)
- installation [118](#)
- memory block size [117](#)
- memory connector described [118](#)
- memory expansion connector [123](#)

### RAM500 bottom side connector (P1) [120](#)

### RAM500 connectors, description [120](#)

### rear panel I/O [37](#)

### reprogram flash, risk [114](#)

## S

### SD command [114](#)

### SDRAM

- management of [117](#)
- RAM500 as memory module [117](#)

### serial ports [84](#)

- COM1/COM2 [131](#)

### COM3/COM4 [132](#)

### SIM

- circuitry described [133](#)
- installation procedure (CPCI-6020-MCPTM-01) [136](#)
- part numbers [132](#)

### SPD, RAM500 [118](#), [120](#)

### speaker output header (CPCI-6020-MCPTM-01) [150](#)

- specification compliancy [32](#)
- specifications, CPCI-6020 [37](#)

### SROM, RAM500 [119](#)

### standard compliancy [32](#)

### startup overview [36](#)

### sync/async serial ports (CPCI-6020-MCPTM-01) [149](#)

### synchronous serial ports [84](#)

### synchronous serial ports, transfer rates [85](#)

## T

### thermal requirements [35](#), [131](#)

### transfer rates, synchronous serial ports [85](#)

## W

### Winbond (PBC) interface to ISA and EIDE devices [84](#)

