



hp
pavilion notebook
zt1000/xz100
series
omnibook notebook

troubleshooting
and self-repair
guide

Notice

This manual and any examples contained herein are provided “as is” and are subject to change without notice. Hewlett-Packard Company makes no warranty of any kind with regard to this manual, including, but not limited to, the implied warranties of merchantability and fitness for a particular purpose. Hewlett-Packard Co. shall not be liable for any errors or for incidental or consequential damages in connection with the furnishing, performance, or use of this manual or the examples herein.

Consumer transactions in Australia and the United Kingdom: The above disclaimers and limitations shall not apply to Consumer transactions in Australia and the United Kingdom and shall not affect the statutory rights of Consumers.

© Copyright Hewlett-Packard Company 2000–2002. All rights reserved. Reproduction, adaptation, or translation of this manual is prohibited without prior written permission of Hewlett-Packard Company, except as allowed under the copyright laws.

The programs that control this product are copyrighted and all rights are reserved. Reproduction, adaptation, or translation of those programs without prior written permission of Hewlett-Packard Co. is also prohibited.

Portions of the programs that control this product may also be copyrighted by Microsoft Corporation, SystemSoft Corp., Insyde Software Corporation, S3 Graphics Incorporated, and Adobe Systems Incorporated. See the individual programs for additional copyright notices.

This product incorporates copyright protection technology that is protected by method claims of certain U.S. patents and other intellectual property rights owned by Macrovision Corporation and other rights owners. Use of this copyright protection technology must be authorized by Macrovision Corporation and is intended for home and other limited viewing uses only unless otherwise authorized by Macrovision Corporation. Reverse engineering or disassembly is prohibited.

Microsoft®, MS-DOS®, and Windows® are U.S. registered trademarks of Microsoft Corporation. Pentium® and the Intel Inside logo are U.S. registered trademarks and Celeron™ and SpeedStep™ are U.S. trademarks of Intel Corporation. Adobe® and Acrobat® are trademarks of Adobe Systems Incorporated.

All certifications may not be completed at product introduction.

This equipment is subject to FCC rules. It will comply with the appropriate FCC rules before final delivery to the buyer.

Hewlett-Packard Company
HP Notebook Customer Care
1000 NE Circle Blvd., MS 425E
Corvallis, OR 97330, U.S.A.

Edition History

Edition 1January 2002

Contents

Product Information	5
Notebook Features.....	5
Operating the Notebook	10
Turning the Notebook On and Off.....	10
Resetting the Notebook	11
Changing the Boot Device.....	11
Hardware Specifications.....	12
Troubleshooting and Diagnostics.....	15
Audio Problems	15
CD and DVD Problems	16
Display Problems.....	17
Floppy Disk Drive Problems	19
Hard Disk Drive Problems	19
Heat Problems	20
Infrared Problems	20
Keyboard and Pointing Device Problems.....	20
LAN Problems.....	21
Memory Problems	22
Modem Problems.....	22
One-Touch Button Problems.....	24
Parallel and USB Problems	25
PC Card (PCMCIA) Problems	26
Performance Problems.....	26
Power and Battery Problems	27
Printing Problems	29
Startup Problems	29
Standby and Resume Problems	30
Wireless Problems	30
Using the e-Diagtools Diagnostic Tests	32
Using the BIOS Configuration Utility.....	33
Reinstalling and Updating Software.....	37
Recovering the Factory Software Installation	37
Updating the Notebook BIOS	38
Updating the Windows Drivers.....	38
Removing and Replacing Parts.....	39
Removing the Battery.....	40
Removing the Optical Drive Module	41
Removing the Hard Disk Drive	42
Removing the Mini-PCI Card	44
Removing the Keyboard Cover	46
Removing the Keyboard.....	48
Removing an SDRAM Module	50
Removing an Expansion SDRAM Module	50
Removing the System SDRAM Module	51
Removing the Speakers	52
Removing the Fan	53
Replacing Small Parts and Accessories.....	55

Reference Information	57
Password Removal Policy	57
Hewlett-Packard Display Quality Statement.....	57

Figures

Figure 1. Front View	5
Figure 2. Back View	6
Figure 3. Bottom View.....	7
Figure 4. Main Status Lights	8
Figure 5. Keyboard Status Lights.....	9
Figure 6. Multimedia Buttons and Status Panel (selected models).....	9
Figure 7. Pressing the Reset Switch.....	11
Figure 8. Removing the Battery	40
Figure 9. Releasing the Plug-in Module	41
Figure 10. Removing the Hard Disk Drive	42
Figure 11. Removing the Hard Disk Tray.....	43
Figure 12. Removing the Mini-PCI Card.....	45
Figure 13. Removing the Keyboard Cover Retaining Screws	46
Figure 14. Removing the Keyboard Cover	47
Figure 15. Loosening the Keyboard Retaining Screws	48
Figure 16. Disconnecting the Keyboard.....	49
Figure 17. Removing an Expansion SDRAM Module	50
Figure 18. Installing an Expansion SDRAM Module	51
Figure 19. Removing the System SDRAM Module	51
Figure 20. Removing the Speakers	52
Figure 21. Removing the Fan.....	54

Tables

Table 1. Battery Replacement Part Numbers	40
Table 2. Optical Drive Module Replacement Part Numbers.....	41
Table 3. Hard Disk Drive Replacement Part Numbers	42
Table 4. Mini-PCI Card Replacement Part Numbers.....	44
Table 5. Keyboard Cover Replacement Part Numbers	46
Table 6. Keyboard Replacement Part Numbers	48
Table 7. SDRAM Module Replacement Part Numbers	50
Table 8. Speaker Replacement Part Numbers.....	52
Table 9. Fan Replacement Part Numbers.....	53
Table 10. Replacing Small Parts	55
Table 11. Accessories	55

Product Information

This section introduces the notebook and its components, and briefly describes basic operation.

Notebook Features

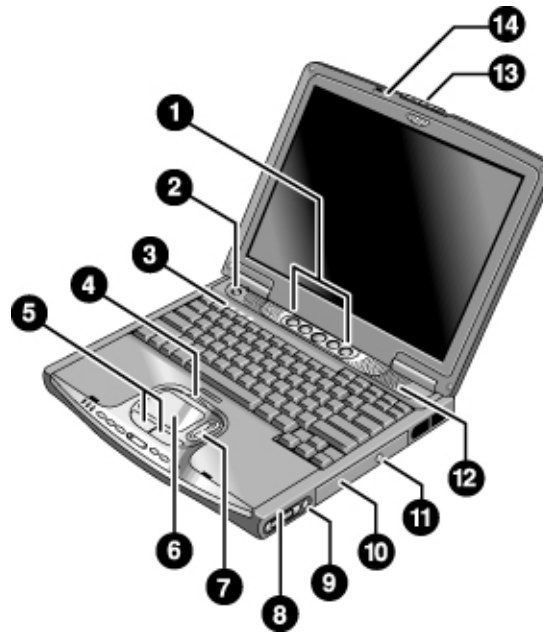

Figure 1. Front View

- | | |
|--|---|
| 1. One-Touch buttons (programmable). | 8. Volume controls (selected models). |
| 2. Power button. | 9. Mute button and indicator light (selected models). |
| 3. Keyboard status lights: Caps Lock, Num Lock, CD/DVD drive activity. | 10. Removable DVD or DVD/CD-RW drive. |
| 4. Touch pad/scroll pad on-off button (with on-off indicators on either side). | 11. CD/DVD eject button. |
| 5. Left and right click buttons. | 12. Speaker (one on each side). |
| 6. Touch pad. | 13. Latch. |
| 7. Scroll pad. | 14. Built-in microphone. |

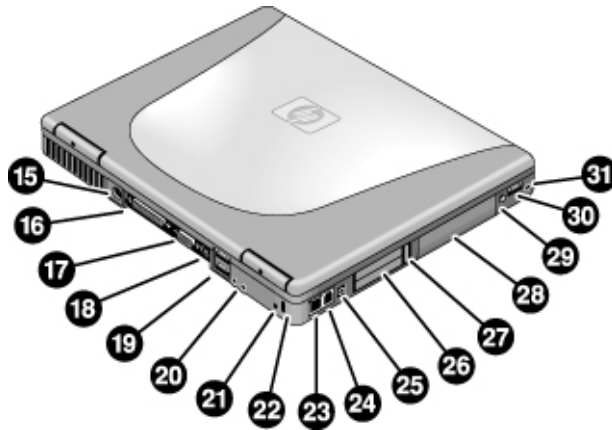

Figure 2. Back View

- | | |
|---|---|
| 15. AC adapter jack. | 23. LAN port and indicators. |
| 16. Parallel port (LPT1) (colored burgundy). | 24. Modem port (selected models). |
| 17. External monitor (VGA) port (colored blue). | 25. IEEE 1394 connector (selected models). |
| 18. S-video (TV out) port (colored yellow) (selected models). | 26. PC Card slot (Type II or Type III, lower slot only). |
| 19. Universal serial bus (USB) ports (2). | 27. PC Card eject button. |
| 20. Audio line-out jack (colored lime green) and external microphone jack (colored pink). | 28. Hard disk drive. |
| 21. Reset switch. | 29. Wireless on-off button and indicator light (selected models). |
| 22. Kensington lock slot (security connector). | 30. Universal serial bus (USB) port. |
| | 31. Headphones jack (colored lime green). |

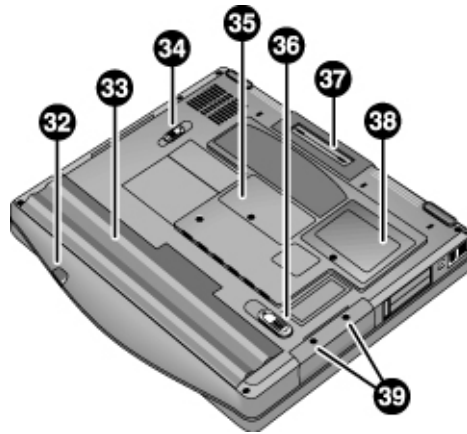

Figure 3. Bottom View

- | | |
|--------------------------------------|--|
| 32. Infrared port (selected models). | 37. Docking port. |
| 33. Battery. | 38. Mini-PCI cover (no user-replaceable parts inside). |
| 34. CD/DVD drive latch. | 39. Hard disk drive retaining screws. |
| 35. RAM cover. | |
| 36. Battery latch. | |

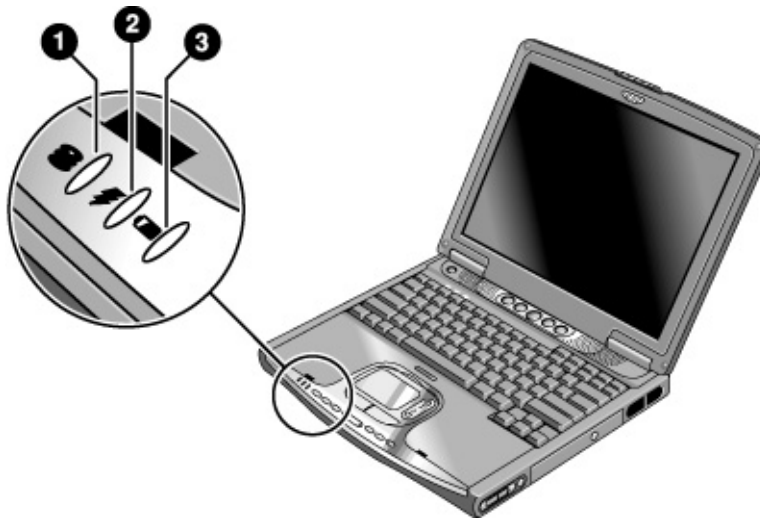

Figure 4. Main Status Lights

1. Hard disk drive activity.

- On: the notebook is accessing the hard disk drive.

2. Power mode.

- Green: the notebook is on (even if the display is off).
- Amber: the notebook is on standby.
- Off: the notebook is off or in hibernation.

3. Battery charge status.

- Green: the AC adapter is connected and the battery is fully charged.
- Amber: the AC adapter is connected and the battery is charging.
- Red: the AC adapter is connected and the battery has a fault.
- Off: the AC adapter is not connected or the battery is missing.

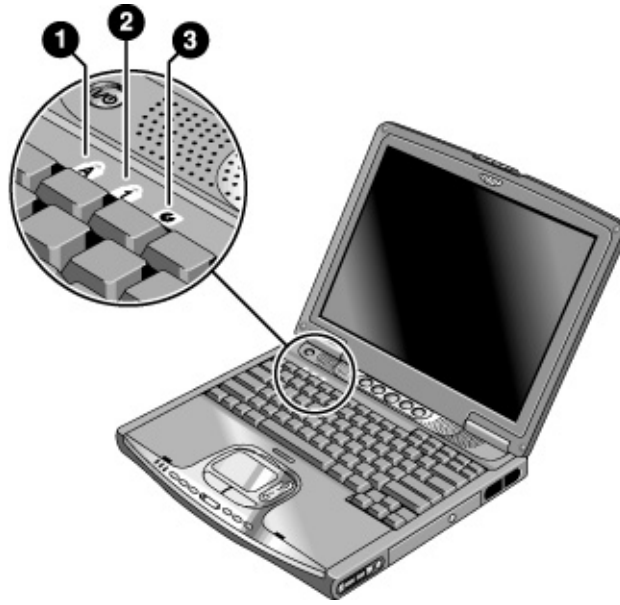

Figure 5. Keyboard Status Lights

1. **Caps Lock.** Caps Lock is active.
2. **Num Lock.** Num Lock is active. (The Keypad Lock must also be on to use the embedded keypad.)
3. **CD/DVD drive activity.** The drive is active.

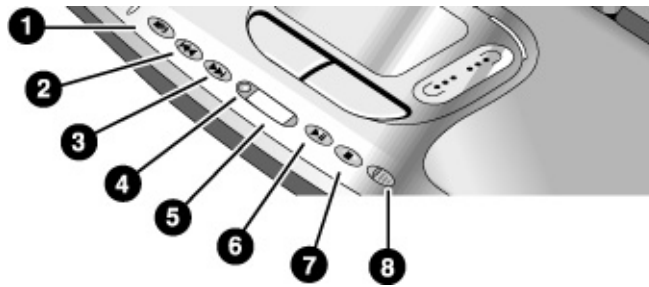

Figure 6. Multimedia Buttons and Status Panel (selected models)

- | | |
|------------------------------|---|
| 1. MP3 player launch button. | 5. Status panel. |
| 2. Previous track button. | 6. Play/Pause button. |
| 3. Next track button. | 7. Stop button. |
| 4. Status panel button. | 8. Multimedia power switch and indicator light. |

Operating the Notebook

Note

This manual describes the notebook in its original factory configuration, with all settings at their default values.

Turning the Notebook On and Off

Power mode	To enter this mode	To turn on again
On Power mode status light is green.	Press the power button.	
Standby Maintains current session in RAM. Turns off the display and other components. Saves significant power. Restarts quickly. Restores network connections. Power mode status light is amber.	Click Start, Turn Off Computer, Stand By. –or– Press the power button. –or– Allow timeout.	Press the power button to quickly resume your session.
Hibernation Saves current session to disk, then turns off. Saves maximum power. Restores network connections. Power mode status light is off.	Click Start, Turn Off Computer, then press and hold Shift and click Hibernate. –or– Allow timeout.	Press the power button to resume your session.
Turn off Turns off without saving current session. Saves maximum power. At startup, resets everything, and starts a new session. Power mode status light is off.	Click Start, Turn Off Computer, Turn Off. –or– Press and hold the power button for four seconds (only if the Start menu procedure doesn't work).	Press the power button to start with a new session.

Resetting the Notebook

If Windows or the notebook stops responding and you cannot turn the notebook off, try the following in the order listed. Press the power button to restart.

- If possible, restart or turn off the notebook from within Windows: click Start, Turn Off Computer, Restart (or Turn Off).
- Press Ctrl+Alt+Del, then click Shut Down, Restart (or Turn Off).
- Press and hold the power button for about four seconds.
- Use a pen or straightened paper clip to press the reset switch on the back of the notebook.

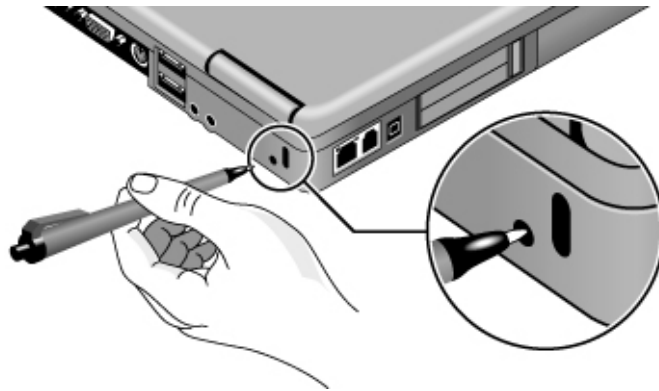

Figure 7. Pressing the Reset Switch

Changing the Boot Device

The notebook normally boots from its internal hard disk. You can also boot the notebook from an external USB floppy disk drive (optional accessory), the CD/DVD drive, or a local area network (LAN).

1. Restart the notebook: click Start, Turn Off Computer, Restart.
2. When the HP logo appears, press Esc to display the Boot menu.
3. Use the arrow keys to select the boot device, and press Enter.

If you want to boot from a specific device whenever it is present, change the boot order using the BIOS configuration utility—see “Using the BIOS Configuration Utility” on page 33.

Hardware Specifications

The specifications shown below are subject to change. For the latest specifications, see the HP Notebook web site (www.hp.com/notebooks).

Physical Attributes	<p>Dimensions: 13.3/14.1-in models: 318 × 273 × 35.8 mm (12.5 × 10.75 × 1.4 in). 15-in models: 330 × 278 × 37.5 mm (12.99 × 10.94 × 1.47 in). Thickness varies across unit. Starting travel weight: 2.3 kg (5.0 lbs) minimum, depending on model.</p>
Processor and Bus Architecture	<p>Intel Mobile Pentium III-M processor (starting at 933 MHz) with SpeedStep technology. –or– Intel Celeron processor (starting at 866 MHz). 1.6-V core, 2.5-V external, low-power processor. 32-bit PCI bus.</p>
Graphics	<p>13.3/14.1/15-in XGA (1024x768) or 15-in SXGA+ (1400x1050) TFT LCD display. Supports 16 million colors, 3D and OpenGL graphics. Supports hardware acceleration for MPEG. Display driver supports MPEG2 overlay. Supports simultaneous LCD+CRT operation (same image on both displays). Integrated VGA. Up to 32-MB video memory (shared with system memory). Supports NTSC and PAL TV. Dual display for LCD and external monitor or TV.</p>
Power	<p>Rechargeable lithium-ion or NiMH battery. Battery life depends on notebook type and usage, and battery type and calibration. Low-battery warning. Standby/hibernate and resume capability. Universal AC adapter: 100–240 Vac (50/60 Hz) input, 19 Vdc output, 60 W.</p>
Mass Storage	<p>10- to 40-GB removable IDE hard disk drive. Supports optional 1.44-MB floppy disk drive module.</p>
CD/DVD drive	<p>8X DVD or 8X8X24X8 DVD/CD-RW (or higher) removable drive.</p>
RAM	<p>Two slots for SDRAM expansion (SODIMM, PC133) up to 1024 MB (2x512MB). 133-MHz RAM bus.</p>
Audio System	<p>Built-in microphone. Stereo sound through two built-in speakers. 1.5 W per channel. Polk Audio certified on 15-in models. Dedicated mute and volume controls (selected models). CD player (can play while notebook is on standby, in hibernation, or off). 3D-enhanced PCI bus audio.</p>
Keyboard and Pointing Devices	<p>87/88/91-key touch-type QWERTY keyboard with 101/102 key emulation. Embedded numeric keypad. 12 function (Fn) keys. 5 user-programmable One-Touch buttons. Touch pad with lock button and on-off indicator. Left and right click buttons, vertical scroll pad.</p>

Input/Output	<p>3 universal serial bus (USB) ports.</p> <p>15-pin VGA video-out (blue) with DDC support. (Resolution up to 1600×1200×64K or 16M colors. Refresh rate of 60 to 100 Hz, depending on resolution and color depth.)</p> <p>RJ-45 LAN jack.</p> <p>25-pin bi-directional high-speed ECP/EPP parallel (burgundy).</p> <p>S-video TV out (yellow) (selected models).</p> <p>4-Mbps IrDA-compliant infrared port (selected models).</p> <p>IEEE 1394 port (selected models).</p> <p>Docking port: supports optional simple port replicator.</p>
Expandability	<p>One Type II or Type III 16/32-bit PC Card slot (3.3- and 5-V support).</p> <p>CardBus enabled.</p> <p>Optional simple port replicator (selected models).</p>
Security Features	<p>User and administrator passwords.</p> <p>DMI-accessible electronic serial number.</p> <p>Kensington MicroSaver lock slot.</p>
Environmental Limits	<p>Operating temperature: 0 to 40 °C (32 to 104 °F).</p> <p>Operating humidity: 10 to 90 percent RH (0 to 45 °C).</p> <p>Operating altitude: up to 10,000 ft (3000 m) at 25 °C (77 °F).</p> <p>Storage (non-operating) temperature: –20 to 65 °C (–4 to 149 °F).</p>
Major ICs	<p>CPU: Intel Mobile Pentium III or Celeron processor.</p> <p>North Bridge: VIA Pro Savage Pn 133T.</p> <p>South Bridge: VIA VT8231.</p> <p>Display controller: S3 Savage 4 in North Bridge.</p> <p>Audio controller: VIA/Realtek ALC201 AC97 Codec.</p> <p>CD player controller: O2 OZ-163.</p> <p>LAN: Realtek RTL8100L.</p> <p>CardBus controller: ENE 1410.</p> <p>Keyboard/embedded controller: National NS87591.</p> <p>Super I/O: in South Bridge.</p>

Troubleshooting and Diagnostics

This section contains solutions to several types of problems you may encounter when using the notebook. Try the solutions one at a time, in the order in which they are presented.

You can also find technical tips and software updates for the notebook at the HP Business Support web site (www.hp.com/go/bizsupport).

Audio Problems

If no sound is audible

- Press Fn+Page Up several times.
- If available, press the rear volume control several times.
- Click the speaker icon on the taskbar (if present), and make sure Mute is not checked and the Volume slider is not set to the bottom.
- If available, press the mute button on the right side of the notebook once or twice until the indicator light goes off.
- The notebook's sound may not operate properly in MS-DOS mode.

If sound does not record

- Check the software controls for recording sound: click Start, All Programs, Accessories, Entertainment, Sound Recorder.
- In Volume Control, click Options, Properties, and make sure the microphone is enabled in the recording controls.
- Test the audio with the e-Diagtools diagnostics— see “Using the e-Diagtools Diagnostic Tests” on page 32.

If you hear a loud high-pitched whine (feedback) from the speakers

- In Volume Control, try reducing the master volume.
- In Volume Control, click Options, Properties, and select the microphone option for the playback settings. Make sure the microphone is muted.
- Avoid using the built-in microphone and built-in speakers at the same time.

CD and DVD Problems

If you can't boot from a CD in the CD/DVD drive

- Make sure the CD is bootable, such as a *Recovery CD*.
- Make sure the CD-ROM/DVD drive is selected as the boot device—see “Changing the Boot Device” on page 11.
- Restart the notebook.
- Test the CD/DVD drive with the e-Diagtools diagnostics— see “Using the e-Diagtools Diagnostic Tests” on page 32.

If a CD or DVD plays erratically

- Dirt or smudges can cause a disk to skip. Clean the disk with a soft cloth. If the disk is badly scratched, it may have to be replaced.
- Some DVDs include software called “PC Friendly.” You generally should not install this software, as it can cause errors or erratic play. If needed, uninstall it and restart the notebook.

If a DVD movie stops playing in the middle

- You may have accidentally paused the DVD movie. Press the Play button to resume.
- The DVD may be double-sided. Open the DVD tray, and read the text near the center of the disk. If it says Side A, flip the disk over, close the tray, and press the Play button to continue playing the movie.

If you get a Region Code error when playing a DVD movie

- DVDs have regional codes embedded in their disk data. These codes prevent DVD movies from being played outside the region of the world in which they are sold. If you get a Region Code error, you are trying to play a DVD intended for a different region.

Important: Most DVD drives let you change the region code only a limited number of times (usually no more than four) to allow you to set the proper region code for your area. Please note that when you reach this limit, your last change to the region code will be hard-coded on the DVD drive, and will be permanent. **The HP warranty does *not* cover the expense of correcting this situation.**

Refer to the help for the DVD player software for details about setting region codes.

If the notebook cannot read a CD or DVD

- For a single-sided CD or DVD, make sure the disk is placed in the drive with the label facing up.
- Clean the disk with a soft cloth.
- Wait 5 to 10 seconds after closing the tray for the notebook to recognize the disk.
- Remove the disk from the drive, then restart the notebook.
- If you created the CD on a CD-RW drive, try using a different media brand. For best results use HP certified media. While other media may work, HP cannot guarantee compatibility.

If a DVD movie doesn't fill the screen

- Each side of a double-sided DVD has a different format (standard or widescreen). In widescreen format, black bands appear at the top and bottom of the screen. To view the standard format, flip the disk over and play the other side.

If you have problems with display resolution or color depth while playing a DVD

- Set the display resolution and color depth before starting the DVD player. You cannot change these once the DVD player is started.
- Some combinations of color depth and resolution are not supported in DVD playback. If needed, reduce color depth or display resolution.

If a DVD doesn't play with two displays

- Before starting the DVD player, press Fn+F5 to switch to one display. You cannot switch displays once the DVD player is started.
- If you're using both displays, the DVD image will not appear on any display set up as "secondary". Click Start, Control Panel, Appearance and Themes, Display. Click Advanced on the Settings tab, then click the S3Display tab and change settings.

Display Problems

If the notebook is on, but the screen is blank

- Move the mouse or tap the touch pad or scroll pad. This will wake the display if it is off.
- Try pressing Fn+F2 to increase the display brightness.
- Press Fn+F5 in case the internal display was disabled. (Do this three times to return to the state you started from.)
- If the notebook is cold, allow it to warm up.

If the screen is difficult to read

- Try setting the display resolution to its default setting of 1024×768: click Start, Control Panel, Appearance and Themes, Display, Settings.

If part of the Windows desktop is not visible and you have to scroll down to see the taskbar, or does not fill the entire display and has a black border

- The display resolution may be set incorrectly. Adjust as needed.

If an external display does not work

- Check the connections.
- Press Fn+F5 in case the external monitor was disabled. (Do this three times to return to the state you started from.)
- Test the display with the e-DiagTools diagnostics— see "Using the e-Diagtools Diagnostic Tests" on page 32.

If one or more display pixels look bad

TFT display manufacturing is a highly precise but imperfect technology, and manufacturers cannot produce displays that are cosmetically perfect. Most, if not all, TFT displays exhibit some level of cosmetic imperfection. These cosmetic imperfections may be visible under varying display conditions, and can appear as bright, dim, or dark spots. *This issue is common across all vendors supplying TFT displays in their products and is not specific to the HP notebook display.*

HP notebook TFT displays meet or exceed all HP standards for cosmetic quality of TFT displays. HP does not warrant that the displays will be free of cosmetic imperfections. *TFT displays can have a small number of cosmetic imperfections and still conform to HP's cosmetic quality specifications, including the following:*

- No more than 6 pixels remain on (always one color, such as white, red, green, or blue dots).
- No more than 6 pixels remain off (always dark).
- No more than a total of 8 pixels stuck on or off.
- No other stuck pixel within 15 mm of a stuck pixel.

Refer to HP Customer Care for a more comprehensive explanation of HP display quality. We expect that over time the industry will continue to produce displays with fewer inherent cosmetic imperfections, and we will adjust our HP guidelines as these improvements are implemented.

If you have problems with display resolution or color depth while playing a DVD or a video file in AVI or MPEG format

- Set the display resolution and color depth before starting the DVD or video file player. You cannot change these settings once the player is started.
- Some combinations of color depth and resolution are not supported in DVD or AVI playback. If needed, reduce color depth or display resolution.

If a DVD or a video file in AVI or MPEG format doesn't play with two displays

- Before starting the DVD or video file player, press Fn+F5 to switch to one display. You cannot switch displays once the player is started.
- If you're using both displays, the DVD or video image will not appear on any display set up as "secondary". Click Start, Control Panel, Appearance and Themes, Display. Click Advanced on the Settings tab, then click the S3Display tab and change settings.

If you have display problems while using a TV set as a monitor

- The notebook's S-video (TV-out) port is optimized for DVD display. Performance may vary when using the S-video port for other applications.
- Before using a TV set as a monitor, switch the notebook's display resolution to 800 by 600 pixels:
 1. Connect a video cable from the TV set to the notebook's S-video port (colored yellow) on the back of the notebook. (You don't need to turn the notebook off to do this.)
 2. Turn on the TV.
 3. Click Start, Control Panel, Appearance and Themes, Display, Settings, then click the Advanced button.
 4. On the S3Display tab, select TV as the Display Device, then click OK.
 5. Set the screen resolution to 800 by 600 pixels, then click OK.

If you have display problems while using a simple port replicator or a CRT monitor

- If you dock to a simple port replicator or attach a CRT monitor while the notebook is off, the notebook may not properly recognize the CRT when you restart the notebook, although its LCD display will be active. If this happens, select your preferred display device either of these ways:
- Press Fn+F5 repeatedly.
- Click Start, Control Panel, Appearance and Themes, Display, Settings, then click the Advanced button. On the S3Display tab, select the Display Device you want, then click OK.

Floppy Disk Drive Problems

If a floppy drive connected to the USB port doesn't work

- Make sure the drive is securely connected to the notebook.
- Restart the notebook: click Start, Turn Off Computer, Restart.

Hard Disk Drive Problems

If the notebook's hard drive doesn't spin

- Make sure the notebook has power. If necessary, connect the AC adapter, and make sure it is fully plugged into a power source and into the back of the notebook.
- Remove and reinsert the hard drive—see “Removing the Hard Disk Drive” on page 42.

If the hard disk makes a buzzing or whining noise

- **Important:** Back up the drive immediately.
- See whether the noise is coming from elsewhere, such as the fan or a PC Card drive.

If files are corrupted

- Check the hard disk: open My Computer, select the disk you want to scan, click File, Properties, and use the Tools tab.
- Run the Norton AntiVirus program.
- Test the hard disk drive with the e-DiagTools diagnostics—see “Using the e-Diagtools Diagnostic Tests” on page 32.
- If necessary, format the hard disk and reinstall the original factory software—see “Recovering the Factory Software Installation” on page 37.

If the hard drive's reported capacity is less than its actual size

- The hard disk drive is preconfigured to allocate some space to diagnostic software, which is used in support and service of your notebook. This part of the hard drive is unavailable for other uses, and so is not included in the capacity of the hard drive as reported by Windows (My Computer, Properties).

Heat Problems

Keep in mind that your notebook normally gets warm during routine operation. Charging the battery and running games and other programs that drive CPU usage toward 100% can further increase the notebook's temperature.

If the notebook gets unusually warm

- Always set the notebook on a firm, flat surface, so that air can flow freely around and beneath it.
- Make sure the air vents on the right side and back of the notebook are clear.
- Make sure the fan is working properly. If needed, test the fan's operation with the e-DiagTools diagnostics— see “Using the e-Diagtools Diagnostic Tests” on page 32.

Infrared Problems

If you have problems with infrared communication

- Make sure the line between the two infrared ports is not blocked, and that the ports face each other as squarely as possible. The ports should be no more than 1 meter apart, with no obstructions between them. Sunlight, heat from nearby equipment, and other sources of infrared radiation can also interfere with infrared communications.
- Make sure only one application is using the infrared port.

Keyboard and Pointing Device Problems

If the pointer is difficult to control

- Adjust the pointer controls: click Start, Control Panel, Printers and Other Hardware, Mouse.

If the touch pad or scroll pad doesn't work

- Don't use the touch pad or scroll pad while the notebook is rebooting or resuming. If this happens, try the following:
 - Press any key on the keyboard.
 - Put the notebook on standby, then resume operation.
- The touch pad and scroll pad are automatically disabled when the notebook is docked in a port replicator that has a PS/2 mouse connected.
- Restart the notebook: click Start, Turn Off Computer, Restart.
- Check settings: click Start, Control Pad, Printers and Other Hardware, Mouse, Scrolling.
- Test the keyboard and pointing devices with the e-DiagTools diagnostics— see “Using the e-Diagtools Diagnostic Tests” on page 32.

If the embedded numeric keypad doesn't work

- To type numbers, make sure Num Lock is on.
- Make sure the embedded Keypad Lock (Fn+F8) is on—or that you press and hold the Fn key to temporarily access the embedded keypad.

If you can't type the euro symbol

- Hold Alt GR when you press the marked key.
- The euro symbol is not on the U.S. English keyboard. Make sure the embedded keypad is active (Fn+F8) and Num Lock is on, then press and hold Alt while typing 0128 on the numeric keypad.
- Support for the euro symbol requires software available from Microsoft. This software is installed in the factory software, but may not be included with retail Windows.

If a special feature on a USB mouse doesn't work

- Make sure you installed any drivers included with the mouse.
- Restart the notebook, so that it will detect the mouse.

LAN Problems

If the built-in network adapter doesn't connect to the LAN

- Check all cables and connections. Try connecting at a different network station, if available.
- If the green light next to the LAN port does not light, the LAN cable may not be connected to the network or the network may be down. Try connecting a different computer to the cable.
- Use the networking problems troubleshooter in Windows Help and Support.
- Click Start, Control Panel, Performance and Maintenance, System. On the Hardware tab, open the Device Manager. If the network interface is disabled, try to enable it. If it has a conflict, try disabling another device.
- Click Start, Control Panel, Network and Internet Connections, Network Connections. Make sure you have the correct clients and protocols installed.
- Make sure the LAN cable is Category 3, 4, or 5 for 10Base-T operation, or Category 5 for 100Base-TX operation. Maximum cable length is 100 meters (330 feet).

If you can't browse My Network Places

- Click Start, Search to look for a computer.

If you can't log in to Netware servers

- If a Netware server is using IPX/SPX protocol, you may need to force your frame type to match the server's frame type. Check with your network administrator.

If the notebook stops responding after booting

- Check whether you have a TCP/IP network with no DHCP server. This can cause a long delay at startup because DHCP is enabled. Contact your network administrator to determine the proper TCP/IP configuration.

Memory Problems

If a message says you are out of memory

- Make sure drive C is not running low on free space.
- Use the memory troubleshooter in Windows Help and Support.
- If you are having memory problems while running MS-DOS programs, use the application and software problems troubleshooter in Windows Help and Support.
- Not all third-party memory cards have been tested for use with the notebook. Check the HP Notebook web site (www.hp.com/notebooks) for a list of approved and tested memory cards.
- Test the notebook's memory with the e-DiagTools diagnostics— see “Using the e-Diagtools Diagnostic Tests” on page 32.

If memory doesn't increase after adding RAM

- Make sure the notebook is using only PC133 RAM modules.

Modem Problems

If the modem seems slow

- Check for excess static or noise on the line, which reduces the overall transmission speed. If necessary, contact your telephone company about fixing this type of problem. (When dialing internationally, line noise can be difficult to eliminate.)
- If you have call-waiting, disable it—your telephone company can provide instructions.
- Eliminate extra connections in the line. If possible, connect directly to the wall jack.
- Try another telephone line, preferably one normally used for a fax machine or modem.

If the modem doesn't dial or no dial tone is detected

- Check all cables and connections.
- Connect a standard telephone to the phone line and make sure the line is working.
- Make sure someone else isn't using the same phone line.
- Try another telephone line, preferably one normally used for a fax machine or modem.
- If you're in a foreign country, the dial tone may not be recognized by the modem. Click Start, Control Panel, Printers and Other Hardware, Phone and Modem Options. Select your modem on the Modems tab, then click Properties, Modem, and disable the option that waits for a dial tone.
- Many countries impose a blackout period after a modem repeatedly fails to connect to a service provider. The number of failed attempts and the period you must wait before trying again differ from country to country: check with your telephone company.

For example, if you are dialing from Italy and fail to connect to your server or cancel the connection, you must wait one minute before dialing that number again. If you dial before then, you will get an error message that says “delay.” After the fourth failed connection, you must wait one hour before trying the number again. If you dial before the hour is up, you will get a message that says “black list.”

If the modem dials incorrectly

- Check the telephone number you entered, including any digits required for outside access or long distance.
- In Control Panel, open Phone and Modem Options, and check the dialing options—look for duplicate digits for outside access or long distance.
- Make sure the number you're calling isn't busy.
- If you're in a foreign country, the dial tone may not be recognized by the modem. Click Start, Control Panel, Printers and Other Hardware, Phone and Modem Options. Select your modem on the Modems tab, then click Properties, Modem, and disable the option that waits for a dial tone.
- If you have call-waiting, disable it—your telephone company can provide instructions.

If the modem dials but doesn't connect

- Make sure you're using an analog telephone line. You must not use a digital line. In a hotel, ask for a data line.
- Try another telephone line, preferably one normally used for a fax machine or modem.
- The modem at the other end may have a problem. Try dialing to a different modem.

If the modem will not connect at 56K speed

- The host modem may not support a 56K (V.90) connection speed.
- Connection speed depends on several factors, such as the condition of the telephone line. Try connecting another time.

If the modem will not connect at any speed

- Make sure you're using an analog telephone line. You must not use a digital line. In a hotel, ask for a data line.
- Make sure the telephone line goes directly from the notebook's modem phone jack to the telephone jack on the wall.
- If you have a single telephone line for voice and modem use, make sure no one else is using the line and that the phone is not off the hook.
- Try another telephone line, preferably one normally used for a fax machine or modem.
- Contact your Internet Service Provider (ISP). It's possible that service may be unavailable temporarily or that your settings are incorrect.
- Restart your notebook and attempt another connection.
- Download the latest modem driver from the technical support area of the HP notebook web site (www.hp.com/notebooks).
- Run the modem diagnostics:
 1. Click Start, Control Panel, Printers and Other Hardware, Phone and Modem Options.
 2. Click the Modems tab, and select the modem you want to test.
 3. Click Properties, Diagnostics, Query Modem.

If the modem isn't detected

- Check the modem setup. In Control Panel, open Phone and Modem Options.
- Click Start, Control Panel, Performance and Maintenance, System. On the Hardware tab, open the Device Manager. If the modem is disabled, try to enable it. If it has a conflict, try disabling another device.
- If you're running fax software using fax Class 2, try using Class 1.

If the modem dials but you can't hear it

- If available, make sure the mute indicator is turned off. If it's on, press the mute button.
- Check the speaker volume setting and mute setting.
- In Control Panel, open Phone and Modem Options. Select the modem and click Properties, then check the volume setting on the Modem tab.

If the modem connects, but transferred data is bad

- In Control Panel, open Phone and Modem Options. Make sure the hardware settings match on sending and receiving modems.

If the modem causes an ERROR message

- A string of AT commands may contain an incorrect command. If you entered commands as extra settings for the modem in Control Panel or in your communications software, check the commands.

If the modem doesn't fax

- If you're using fax Class 2 in the fax software, try using Class 1.
- Close any other communications programs.
- If you're faxing by printing from an application, make sure you've selected the fax printer.
- Try turning off power management features temporarily.

If the modem clicks repeatedly but doesn't connect

- Make sure you're using an analog telephone line. You must not use a digital line. In a hotel, ask for a data line.
- Check all cables and connections.

One-Touch Button Problems

If One-Touch buttons are not working properly

- Make sure the items associated with the buttons are the ones you want.

If the onscreen display does not appear when pressing a One-Touch button

- Make sure the Onscreen Display is enabled.

Parallel and USB Problems

If a USB mouse doesn't work properly

- Make sure you followed the manufacturer's installation instructions completely and have installed the mouse properly. If not, repeat the procedure.
- Make sure the port connection is secure.
- Put the notebook on standby, then resume.
- Restart the notebook.
- Check mouse settings in Control Panel.
- Check the port settings in Control Panel: click Start, Control Panel, Performance and Maintenance, System. On the Hardware tab, open the Device Manager, and double-click Universal Serial Bus Controllers.

If a USB modem doesn't work properly

- See "Modem Problems" on page 22.
- Make sure the port connection is secure.
- Use the modem troubleshooter (under Networking problems) in Windows Help and Support.
- Check the modem settings in Control Panel.
- Disable the internal modem:
 1. Click Start, Control Panel, Performance and Maintenance, System. On the Hardware tab, open the Device Manager.
 2. Double-click Modem to list the current modem devices.
 3. Double-click the internal modem, then select the option to disable the modem.
- Check the port settings in Control Panel: click Start, Control Panel, Performance and Maintenance, System. On the hardware tab, open the Device Manager, then double-click Universal Serial Bus controllers.

If the parallel port is not working

- Make sure the port connection is secure.
- Check the port settings in Control Panel: click Start, Control Panel, Performance and Maintenance, System. On the Hardware tab, open the Device Manager, and double-click Ports (COM & LPT).
- Test the ports with the e-DiagTools diagnostics— see "Using the e-Diagtools Diagnostic Tests" on page 32.

If the USB port is not working

- Contact the vendor of the peripheral device and check the HP Notebook web site (www.hp.com/notebooks) for the latest versions of the USB drivers and the driver for the device.
- Check the port settings in Control Panel: click Start, Control Panel, Performance and Maintenance, System. On the Hardware tab, open the Device Manager, and double-click Universal Serial Bus controllers.
- Test the USB port with the e-DiagTools diagnostics— see "Using the e-Diagtools Diagnostic Tests" on page 32.

PC Card (PCMCIA) Problems

If the notebook doesn't recognize a PC card

- Remove and reinsert the PC card.
- Put the notebook on standby, then resume.
- Restart the notebook.
- If the card requires an IRQ, make sure one is available. If necessary, set the IRQ to an unused value: click Start, Control Panel, Performance and Maintenance, System. On the Hardware tab, open the Device Manager, then view resources by type.
- Check the HP Business Support web site (www.hp.com/go/bizsupport) for information about installing certain PC cards.
- Make sure your notebook supports the problem PC card: check the HP Notebook web site (www.hp.com/notebooks) for a list of approved and tested PC cards.
- Try the card in another computer to see whether the card functions properly.
- Test the PC card with the e-DiagTools diagnostics— see “Using the e-Diagtools Diagnostic Tests” on page 32.

If an I/O card stops communicating properly

- The card may have been reset if your notebook went on standby or into hibernation, or turned off. Exit any applications, then remove and reinsert the card.
- Check settings in Control Panel.

If a PC card modem is not working

- Disable the internal modem:
 1. Click Start, Control Panel, Performance and Maintenance, System. On the Hardware tab, open the Device Manager.
 2. Double-click Modem to list the current modem devices.
 3. Double-click the internal modem, then select the option to disable the modem.

Performance Problems

For best performance with Windows XP, the notebook should have at least 128 MB of SDRAM.

If the notebook pauses or runs sluggishly

- This may be normal Windows behavior. Certain background operations (such as a virus-scanning program) can affect response time.
- Some file browsers respond slowly while processing graphics or waiting for broken network connections to time out.
- Press Ctrl+Alt+Del to see if an application is not responding.
- Restart the notebook.

- If the notebook's hard disk drive frequently runs (as indicated by the hard drive light on the front of the notebook) while the notebook appears to be paused or running slowly, Windows is likely spending excess time writing to its swap file on the notebook's hard disk. Consider installing additional memory.
- Check the amount of available free disk space. Delete temporary and unneeded files.

If the notebook stops responding

- Press Ctrl+Alt+Del to end the application that is not responding.
- Reset the notebook—see “Resetting the Notebook” on page 11.

Power and Battery Problems

If the notebook turns off immediately after it turns on

- Battery power is probably extremely low. Plug in the AC adapter or insert a charged battery.

If the notebook keeps beeping

- The notebook beeps repeatedly when battery power is low (you can set this option in Power Options in Control Panel). Save your work, turn off the notebook immediately, and insert a charged battery or plug in the AC adapter.

If the battery doesn't charge

- Make sure that the AC adapter is fully plugged into the power source and the notebook, and that the light on the adapter is on.
- If you're using a power strip, unplug the AC adapter from the power strip and plug it directly into a wall outlet.
- Make sure the battery is fully installed and locked in place.
- Move the notebook away from any nearby heat source. Unplug the AC adapter and allow the battery to cool down. If the battery gets too hot, it will not charge properly.
- If available, try another battery and AC adapter.

If the notebook has a short operating time

- Turn down the display brightness.
- Check the timeout settings in Power Options in Control Panel.
- If you are running an application that has an automatic save feature (such as MS Word), disable this feature or increase the specified save time to reduce hard disk access.
- PC card use and heavy modem use can affect battery operating time.

- Certain applications can cause excess CPU and power usage. (Users can get Intel Power Monitor from www.intel.com and monitor CPU load.)
- When playing DVD movies on battery power, use Power Options in Control Panel to select the Portable/Laptop power scheme.
- You may need to periodically train the battery and calibrate the battery gauge. To do this, restart the notebook, press F6 when the HP logo appears, and follow the instructions that appear onscreen. This process requires four to five hours to complete, and you cannot use the notebook during this time.
- Battery life depends on notebook model and usage, as well as battery type, training, and calibration. The following are **approximate** lifespans by battery type:
 - 8-cell Li-Ion: up to 3.5 hours.
 - 6-cell Li-Ion: up to 2.5 hours.
 - 8-cell NiMH: up to 2 hours.
- Rechargeable batteries tend to degrade over time. If the operating time has gradually become shorter and the battery is more than a year or two old, you may need to replace the battery.

If the Time Remaining for the battery is not correct

- The Time Remaining is an estimate based on the rate at which the notebook is using power at that instant. So, if you check the Time Remaining while the notebook is using a good deal of power (such as when reading from a CD or DVD), the value will likely show less time remaining than you really have, since you will probably later switch to tasks that require less power.

If the notebook doesn't go on standby as expected

- If you have a connection to another computer, the notebook won't go on standby if the connection is active.
- If the notebook is performing an operation, it normally waits for the operation to finish before going on standby.

If the notebook doesn't automatically hibernate as expected

- Make sure hibernation support is enabled: click Start, Control Panel, Performance and Maintenance, Power Options, then click the Hibernate tab.

Also, check the Power Schemes tab. Make sure the Hibernate timeouts for both AC power and battery power are not set to Never.

Printing Problems

Hint

You can solve most printing problems by using the printing troubleshooter in Windows Help and Support.

If a printer doesn't print

- Make sure the printer is on and has paper in it.
- Make sure you are using the correct printer cable or cable adapter, and that the cable is secure at both ends.
- Check for printer errors.

If the left edge of printed output is missing

- Certain applications may not work properly with 600-dpi printers. If you're using such a printer, try selecting a compatible printer driver for a 300-dpi printer. For example, if you were using a 600-dpi HP LaserJet printer, you might try using the HP LaserJet IIIsi driver (300 dpi).

If an infrared printer doesn't print

- Make sure the printer is on and has paper in it.
- Check for printer errors.
- Make sure Windows is running; otherwise infrared printing is not available.
- See "Infrared Problems" on page 20.

Startup Problems

If the notebook doesn't respond when you turn it on

- Connect the AC adapter.
- Reset the notebook by using a pen or straightened paper clip to press the reset switch on the back of the notebook. Then press the power button to turn the notebook on.
- Don't use the touch pad while booting or resuming.
- If the notebook still doesn't respond, remove the battery and AC adapter, and remove any PC Card. Then reset the notebook using the reset switch on the back of the notebook, replace the battery and plug in the AC adapter, and turn on the notebook by pressing the power button.

If the notebook won't boot from battery power

- Make sure the battery is properly inserted and fully charged. Check the battery's charge by clicking the power icon in the taskbar, or using Power Options in Control Panel.
- If available, try another battery.

If the notebook won't boot from the floppy disk drive

- Make sure the drive is installed correctly.
- Make sure the floppy disk drive is selected as the boot device—see “Changing the Boot Device” on page 11.

If the notebook takes a long time to resume

- The notebook can routinely take a minute or more to resume if it has a network card installed. While the operating system is loading drivers and checking hardware and network connections, you will see a blinking cursor on your display. As soon as the hardware has been re-initialized, the Windows desktop will appear.

Standby and Resume Problems

If the notebook takes a long time to resume after being on standby

- The notebook can take a minute or longer to resume if a network card is installed. A blinking cursor appears on the display while the system is loading and checking hardware and network connections. As soon as the hardware is reinitialized, the Windows desktop appears.

If you have general problems resuming from standby or hibernation

- Close all applications before going on standby or into hibernation.
- If the problems appeared after you installed new software (including drivers, such as printer drivers), uninstall the software. Contact the software application or device vendor for additional support.

If a notebook with Bluetooth won't enter standby or hibernation

- Disable Bluetooth. If the Bluetooth device is transmitting, the notebook may not be able to enter standby or hibernation.

Wireless Problems

If you have problems with wireless communication

- Make sure the wireless indicator light is on.
- See “LAN Problems” on page 21.

If you have trouble connecting to another computer in My Network Places

- Wait a few minutes, then press F5 to refresh the list of computers on the network.
- Click Start, Search to locate the computer.

If you cannot connect to a particular computer on the network

- Make sure the computer is properly connected to the network.
- Make sure your TCP/IP setup is correct for your network: click Start, Control Panel, Network and Internet Connections, Network Connections. Contact your system administrator for the correct settings.

If the wireless link icon in the taskbar is red

- Make sure you are using the correct SSID and channel settings: click the wireless link icon in the taskbar and select Advanced Configuration. Contact your system administrator for the correct settings.
- Make sure you are in range of an access point (for an infrastructure connection) or other wireless computer (for an AdHoc connection).

If you can connect, but the network is slow

- Check whether you might be in an area served by more than one wireless LAN. If so, the LANs could be interfering with each other.
- Move closer to the access point (for an infrastructure connection) or other wireless computer (for an AdHoc connection). You could be too far away for high-speed communication.
- Stop using any USB device that may be transferring large amounts of data, or adjust application settings to reduce the transfer rate.

If a notebook with Bluetooth won't enter standby or hibernation

- Disable Bluetooth. If the Bluetooth device is transmitting, the notebook may not be able to enter standby or hibernation.

Using the e-Diagtools Diagnostic Tests

The e-Diagtools hardware diagnostic program included with your notebook provides two levels of testing: automated testing using its basic hardware test, and advanced testing using individual hardware tests.

The tests are designed to run after the system reboots. This ensures that the notebook will be in a predictable state, so the diagnostic program can properly test the hardware components. The tests are non-destructive and are intended to preserve the state of the notebook. The notebook reboots when you exit the program so drivers can be loaded.

1. Restart the notebook: click Start, Turn Off Computer, Restart.
2. When the HP logo appears, press F10 to start the diagnostic test.
3. When the menu appears, press Enter to run e-Diagtools.

The first time you run the program, you are prompted to select the language for the program.

4. Follow the prompts to run e-Diagtools.
5. When the Configuration Description appears, verify the list of detected hardware.
6. **Run the basic test.** Press F2 to start the basic hardware test. The results appear when the test is complete.
7. If you intend to exit without running the advanced tests, press F4 and then F7 to view the Support Ticket. Press Esc and then F3 to exit.
8. **Optional: Run the advanced tests.** Press F2 to open the advanced test screen.
9. Select and run the appropriate tests. Tests are listed only for detected hardware. Press the following keys to run tests:

Enter	Runs the highlighted test.
F5 or Space	Marks or unmarks the highlighted test.
F6	Marks or unmarks all tests in the current menu.
F7	Marks or unmarks all tests in all menus.
F10	Runs all marked tests.

10. **Save the Support Ticket.** Press T to update and display a Support Ticket containing system and test information. Press Esc to exit.
11. When you are finished running tests, press Esc to exit the advanced tests.
12. **Optional:** To save the Support Ticket to a floppy disk, press F7, then Alt+C.
13. **Exit.** Press F3 and then any key to exit and reboot.
14. **Optional: open the Support Ticket.** In Windows, click Start, All Programs, HP e-DiagTools, e-DiagTools for Windows.
15. Click View to display the Support Ticket.

16. To add information about your problem, click Comments and type the information, then click OK.

To save or print the Support Ticket, click Save As or Print.

To e-mail the Support Ticket to your support agent, click e-Mail. The first time you make an e-mail connection from this program, click Change Settings in the Connect window and enter the settings recommended by your support agent.

e-DiagTools for Windows can also update the version of e-Diagtools on your notebook's hard disk. In e-DiagTools for Windows, use the e-Diagtools menu.

If you have trouble running e-Diagtools from the hard disk, you can also run it from the *Recovery CDs*. Boot from disk 1 and select the diagnostics option.

Using the BIOS Configuration Utility

The BIOS (Basic Input and Output System) configuration utility enables you to change the notebook's system configuration, and to tailor the operation of your notebook to your individual work needs.

1. Restart the notebook: click Start, Turn Off Computer, Restart.
2. When the HP logo appears, press F2 to enter the BIOS configuration utility.
3. The pointing devices are not active in the BIOS configuration utility, so you will need to use the keyboard to navigate:
 - Press the left and right arrow keys to move among menus.
 - Press the up and down arrow keys to move among parameters in a menu.
 - Press Enter to open the dialog for the current parameter, or to select the parameter.
 - Press Tab or the left and right arrow keys to move among selections in a dialog.
 - Press the up and down arrow keys to move through values for the setting.
 - Press Enter to close the dialog and accept the settings.
4. After you select the options you want, use the Exit menu to exit the BIOS configuration utility.

The following tables describe the settings for the notebook's initial BIOS release. If your notebook's BIOS version is different, some settings may differ from those shown, or may be absent.

Startup Menu

Setting	Description	Default
Date and Time	Sets the date using mm/dd/yyyy format and the time using 24-hour format. Value set takes effect immediately.	
Boot Device	Shows the order of boot devices, with "+" indicating a device category. Move the entries to change the order. If the notebook has more than one device in a category, you can select the one scanned. Internal LAN appears in the list only if a built-in LAN is present—it provides diskless boot from a network server.	1. Hard Disk 2. CD-ROM/ DVD 3. Diskette A 4. Internal LAN
CPU Serial Number	For a processor with a serial number, makes the processor serial number available to software.	Enabled

Components Menu

Setting	Description	Default
Keyboard Numlock	Sets whether keyboard Num Lock is enabled at startup.	Enabled
LCD Display on/off (selected models)	Enables the LCD status panel.	Enabled
LCD Display Date/Time (selected models)	Sets the format for displaying the date and time on the LCD status panel.	mm/dd/yy hh:mm AM/PM

Security Menu

Setting	Description	Default
Set Admin Password	Press Enter to set, change, or clear the administrator password, which protects BIOS settings. The password can have no more than 8 characters (0-9, A-Z), and cannot include special or accented characters. Also sets whether the password is required when the notebook boots, or to enter the BIOS configuration utility.	Enter
Set User Password	Press Enter to set, change, or clear the user password. The password can have no more than 8 characters (0-9, A-Z), and cannot include special or accented characters. (The administrator password must be set first.) Also sets whether the password is required when the notebook boots, or to enter the BIOS configuration utility.	Enter

Exit Menu

Setting	Description	
Save and Reboot	Saves changes, then exits and reboots.	
Exit (No Save)	Discards any changes made since last save, then exits and reboots. Does not affect password, date, or time changes.	
Default Settings	Restores default settings, and remains in the BIOS configuration utility. Does not affect password, date, or time changes.	
Restore Settings	Discards any Setup changes made since last save, and remains in Setup. Does not affect password, date, or time changes.	

Reinstalling and Updating Software

You can use the *Recovery CDs* to recover the original factory software for your notebook.

The *Recovery CDs* also provide Windows drivers specific to your notebook to configure a custom system. You can find drivers in these locations:

- On your notebook's hard drive under C:\hp\drivers.
- On the *Recovery CDs* under \hp\drivers.
- On the HP Business Support web site (www.hp.com/go/bizsupport). This web site contains the latest updates of software drivers for different operating systems.

Recovering the Factory Software Installation

You can use the *Recovery CDs* to reinstall the original factory software on your notebook's hard disk. You can also use the same process to create a larger Utility partition on your hard disk, or to create a Utility partition on a new hard disk. The hidden Utility partition contains the e-Diagtools diagnostic tests and stores hibernation data for operating systems that don't provide hibernation.

CAUTION

This procedure formats the notebook's hard disk drive and erases all data on the disk. After the hard disk is formatted, you'll need to reinstall your applications.

Do not interrupt the following process or unplug the AC adapter until the process is complete.

1. **Important:** if possible, back up all data from the notebook's hard disk. The following steps delete all data from the disk.
2. Connect the AC adapter to the notebook.
3. Insert the *Recovery CD* (disk 1) into the notebook's CD/DVD drive. If the notebook is turned off, use a pin or straightened paper clip to press the release switch on the drive door to open it.
4. Turn on or restart the notebook. If the notebook is running, click Start, Turn Off Computer, Restart.
5. When the HP logo appears, press Esc to display the Boot menu.
6. Use the arrow keys to select the CD-ROM/DVD drive as the boot device, and press Enter.
7. When the *Recovery CD* dialog box appears, follow the displayed instructions. If prompted, accept the recommended partition size. If you install the factory software, the recovery process can take up to 15 minutes.

If you want to create the Utility partition without installing the factory software, click Advanced and select not to install the operating system.

If your hard disk is partitioned into several drives, you can install the factory software on drive C without affecting other drives. Click Advanced and select to restore only the C partition.

8. **Important:** when prompted to reboot the notebook, press Ctrl+Alt+Del and follow any instructions that appear.

Updating the Notebook BIOS

Hewlett-Packard may provide updates to the notebook's BIOS to enhance the capabilities of your system. Check the HP Business Support web site (www.hp.com/go/bizsupport). Installation utilities and instructions will be provided with the updates.

Updating the Windows Drivers

From time to time, HP releases updated versions of the drivers for your notebook. These updates are intended to fix any problems that could be encountered in the drivers, and to keep your notebook running smoothly. In addition, HP normally provides drivers for other versions of Microsoft Windows, in case you decide to install a different version of Windows.

- Download the latest drivers for your notebook from the HP Business Support web site (www.hp.com/go/bizsupport). Follow the instructions included with the drivers.

Removing and Replacing Parts

This chapter shows how to remove and replace the notebook's user-replaceable components.

Caution

Always provide proper grounding when performing repairs. Without proper grounding, an electrostatic discharge can damage the notebook and its components.

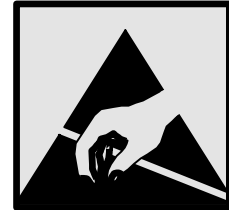

Notes

To reassemble a component, perform the removal procedure in reverse order. Any special notes required for reassembly are included at the end of each section.

■ Symbols like this are used throughout this chapter to show approximate full-size screw outlines. Use these to verify the sizes of screws before you install them. Installing a wrong-size screw can damage the notebook. (The symbol shown represents an M2.5×5mm T-head screw.)

Removing the Battery

Table 1. Battery Replacement Part Numbers

Description	Part Number	Exchange Part Number
Battery, Lilon 8-cell	F3172-60901	

Required Equipment

- None.

Removal Procedure

- Slide the battery's release latch in the direction of the arrow on the latch, then lift the battery out of its compartment.

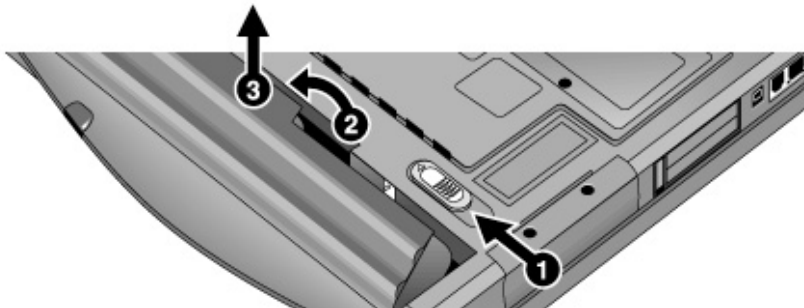

Figure 8. Removing the Battery

Reassembly Notes

- Insert the front end of the battery into the battery compartment, then press the back end in until the battery clicks into place.

Removing the Optical Drive Module

Table 2. Optical Drive Module Replacement Part Numbers

Description	Part Number	Exchange Part Number
Drive, DVD module	F3377-60962	
Drive, DVD/CD-RW Combo module	F3377-60963	

Required Equipment

- None.

Removal Procedure

- Slide the module release latch in the direction shown by the arrow on the latch, and remove the module.

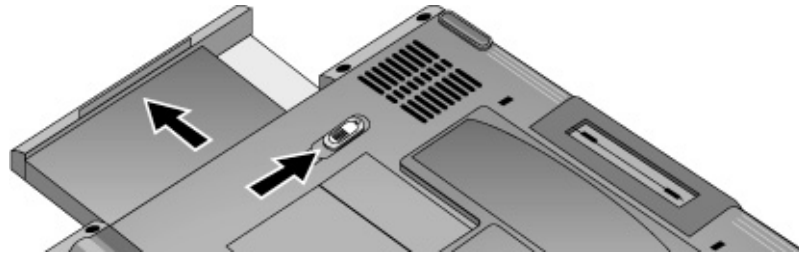

Figure 9. Releasing the Plug-in Module

Removing the Hard Disk Drive

Table 3. Hard Disk Drive Replacement Part Numbers

Description	Part Number	Exchange Part Number
Drive, hard disk (20 GB, 9.5mm, Hitachi ATA100)	0950-4193	F3257-69105
Drive, hard disk (20,GB, 9.5mm, IBM [diablo] ATA100)	0950-4163	F1660-69114
Drive, hard disk (30 GB, 9.5mm, IBM [diablo] ATA100)	0950-4162	F2072-69115
Drive, hard disk (30 GB, 9.5mm, Hitachi ATA100)	0950-4168	F3257-69106
Drive, hard disk (40 GB, 9.5mm, Hitachi ATA100) (zt1100/xz100 series only)	0950-4313	F3378-69101
Drive, hard disk (40 GB, 9.5mm, Toshiba ATA100) (zt1100/xz100 series only)	0950-4288	F3378-69102
Tray, hard disk drive	F3377-60966	

Required Equipment

- #0 Phillips screwdriver.

Removal Procedure

1. Unplug the AC adapter, if present, and remove the battery.
2. On the bottom of the unit, remove both hard drive retaining screws.

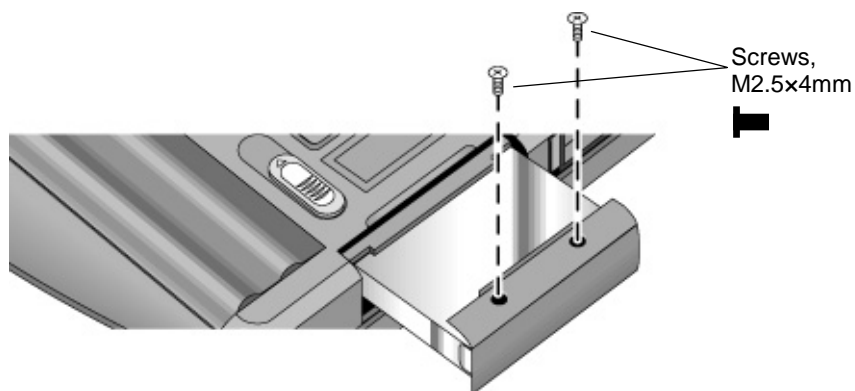

Figure 10. Removing the Hard Disk Drive

3. Carefully pull the hard drive out of the notebook.
4. Remove all four screws from the hard drive tray and drive case, then lift the drive out of the tray.

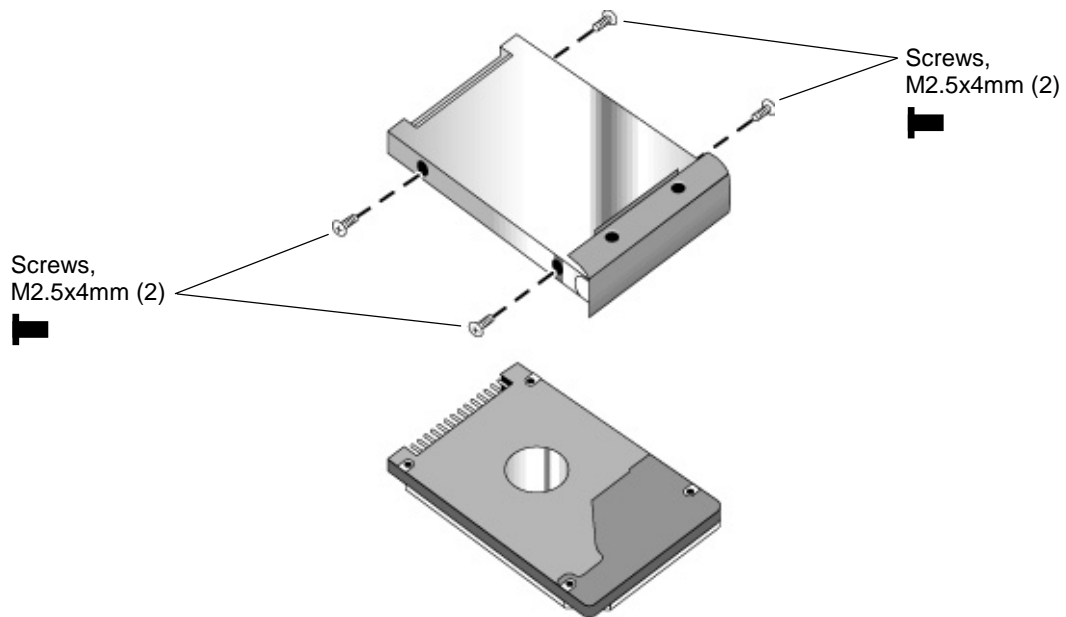

Figure 11. Removing the Hard Disk Tray

Reassembly Notes

- Insert the connector end of the drive through the opening in the tray, then lower the drive into place.
- Carefully slide the hard drive assembly into its compartment. Press firmly to make sure the connector seats properly.

Important

If you are installing a new hard disk drive, install the factory software and operating system on the drive before loading any additional software—see “Recovering the Factory Software Installation” on page 37.

Removing the Mini-PCI Card

Certain notebook models include a mini-PCI card that contains either a modem or combined modem and 802.11 wireless.

Table 4. Mini-PCI Card Replacement Part Numbers

Description	Part Number	Exchange Part Number
PCA, mini-PCI (modem)	F3377-60950	
PCA, mini-PCI (modem/802.11)	F3377-60951	

Caution

Provide proper grounding and handle the card only by its edges, or you could damage it through electrostatic discharge.

Required Equipment

- #0 Phillips screwdriver.

Removal Procedure

1. Unplug the AC adapter, if present, and remove the battery.
2. On the bottom of the notebook, loosen the screw holding the mini-PCI cover (the cover retains the screw), and remove the cover.
3. Press outward to release the latches at the sides of the card, and carefully lift its free edge up.
4. Disconnect the cable(s) from the card.
5. Gently pull the card out of its connector.

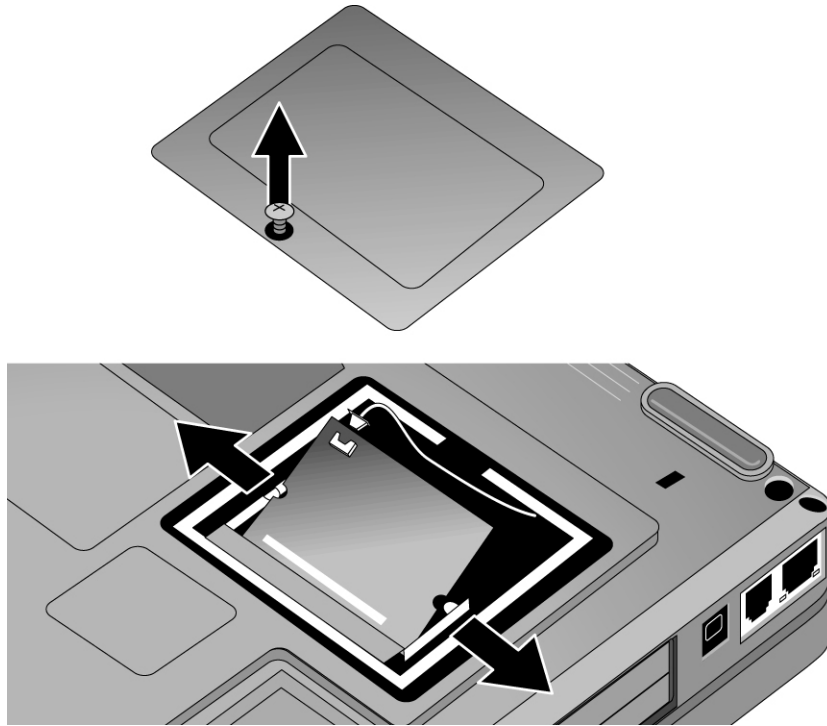

Figure 12. Removing the Mini-PCI Card

Reassembly Notes

- Reattach the cable(s) to the card, and tuck them into the compartment.
- Gently press the card into the connector at an angle of about 30°, until it is fully inserted. Then press down on both sides of the card until the latches snap closed.

Removing the Keyboard Cover

Table 5. Keyboard Cover Replacement Part Numbers

Description	Part Number	Exchange Part Number
Cover, keyboard, 15-in (with LED lens) (zt1100/xz100 series only)	F3379-60911	
Cover, keyboard, 15-in (with LED lens) (xt1000 series only)	F3433-60911	
Cover, keyboard (with LED lens) (zt1100/xz100 series only)	F3377-60924	
Cover, keyboard (without LED lens)	F3377-60925	

Required Equipment

- #0 Phillips screwdriver.
- Small flat-blade screwdriver.

Removal Procedure

1. Unplug the AC adapter, if present, and remove the battery.
2. Close the notebook's display, and remove both screws from the backs of the hinge covers.

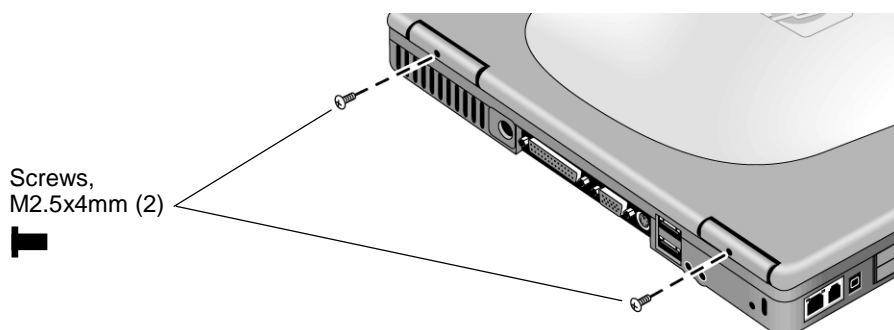

Figure 13. Removing the Keyboard Cover Retaining Screws

3. Open the display so that it lays flat.
4. Use the flat-blade screwdriver to carefully pry up the right end of the keyboard cover just above the Page Up key, then lift the end until the cover unsnaps.

Caution

When removing the keyboard cover, be careful not to pull on the cable that connects the keyboard cover to the notebook.

5. Carefully lift the cover to unsnap the latches above the center One-Touch button and the F1 key, then lift the cover about an inch off of the notebook.

6. Disconnect the keyboard cover switch cable from the motherboard, and remove the cover from the notebook.

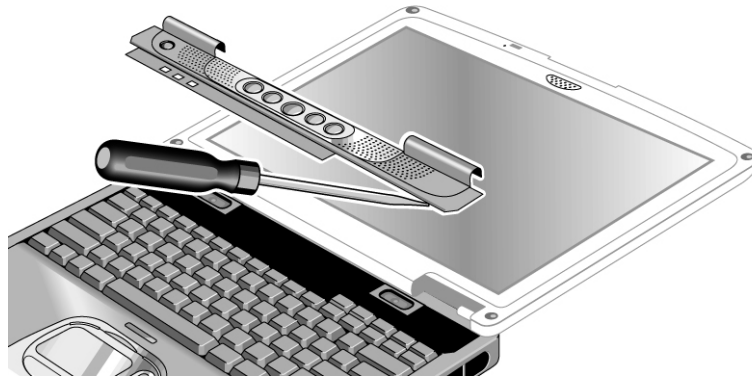

Figure 14. Removing the Keyboard Cover

Reassembly Notes

- Make sure the keyboard cover switch cable is securely connected to the motherboard.
- Bend the center of the keyboard cover upward slightly, and insert the tabs on the ends of the cover into the slots in the notebook's case. Fit the hinge covers over the hinges, and gently press the cover into place.

Removing the Keyboard

Table 6. Keyboard Replacement Part Numbers

Description	Part Number	Exchange Part Number
Keyboard, US English (zt1100/xz100 series only)	F3428-60901	
Keyboard, French (zt1100/xz100 series only)	F3428-60903	
Keyboard, UK English (zt1100/xz100 series only)	F3428-60902	
Keyboard, Italian (xt1000 series only)	F3428-60904	
Keyboard, German (xt1000 series only)	F3428-60911	
Keyboard, Spanish (xt1000 series only)	F3428-60905	
Keyboard, Swiss (xt1000 series only)	F3428-60908	

Required Equipment

- #0 Phillips screwdriver.
- Small flat-head screwdriver.

Removal Procedure

1. Unplug the AC adapter, if present, and remove the battery.
2. Remove the keyboard cover (page 44).
3. Loosen the three retaining screws along the top of the keyboard (the keyboard retains the screws).

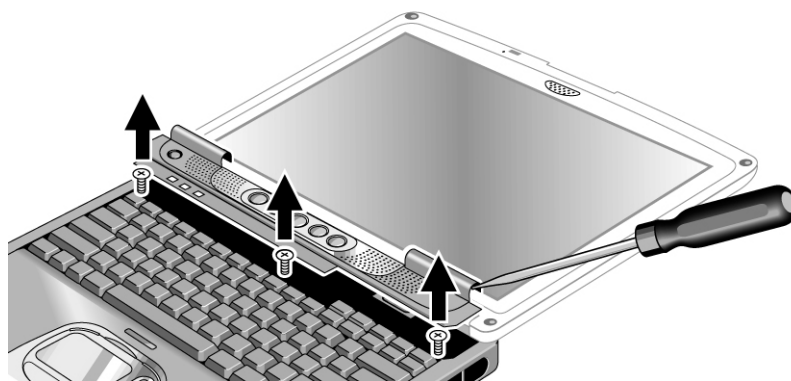

Figure 15. Loosening the Keyboard Retaining Screws

Caution

When opening the keyboard, be careful not to pull on the ribbon cable that connects the keyboard to the notebook.

4. Raise the top of the keyboard, then lift the keyboard up and out of the notebook.

5. Lay the keyboard face down on the top case, forward of its normal position, and disconnect the ribbon cable from the motherboard.

Warning

Do not touch the metal surfaces inside the notebook until they have cooled off. They could be very hot if the notebook was running recently.

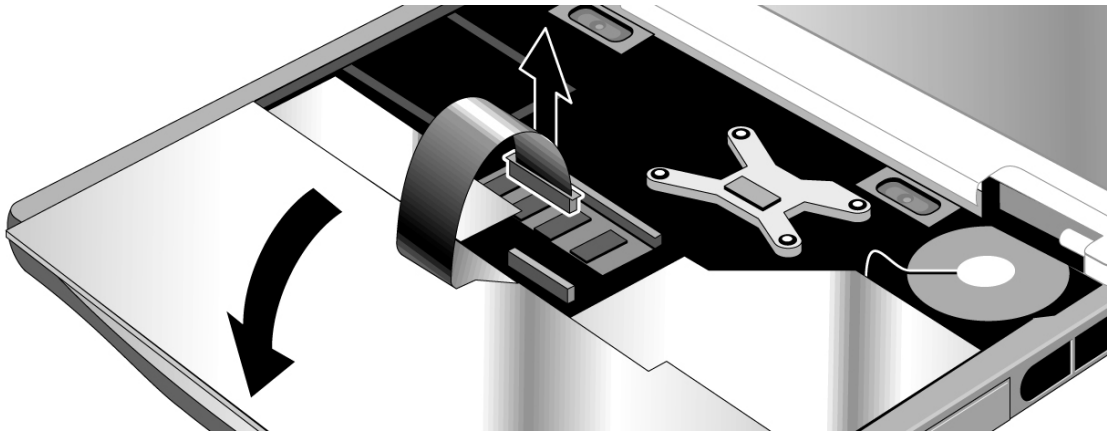

Figure 16. Disconnecting the Keyboard

Reassembly Notes

- Lay the keyboard face down on the top case, forward of its normal position, and reconnect the ribbon cable.
- Slip the metal tabs on the bottom of the keyboard into their slots in the top case, then lower the keyboard into place.

Removing an SDRAM Module

The notebook has no SDRAM built into its motherboard, but has two slots for PC133 SDRAM modules: a system SDRAM slot beneath the keyboard (containing an SDRAM module installed at the factory), and an expansion slot on the bottom of the unit.

Table 7. SDRAM Module Replacement Part Numbers

Description	Part Number	Exchange Part Number
Module, SDRAM, 128 MB, PC133 SODIMM	1818-8504	
Module, SDRAM, 256 MB, PC133 SODIMM	1818-8635	
Module, SDRAM, 512 MB, PC133 SODIMM	1818-8604	F2298-69001

Caution

Provide proper grounding and handle the SDRAM module only by its edges, or you could damage the module through electrostatic discharge.

Required Equipment

- #0 Phillips screwdriver.

Removing an Expansion SDRAM Module

Removal Procedure

1. Unplug the AC adapter, if present, and remove the battery.
2. On the bottom of the notebook, loosen the screw holding the SDRAM cover (the cover retains the screws), and remove the cover.
3. Press outward to release the latches at the sides of the SDRAM module (so that the free edge of the module pops up), then pull the module out of the connector.

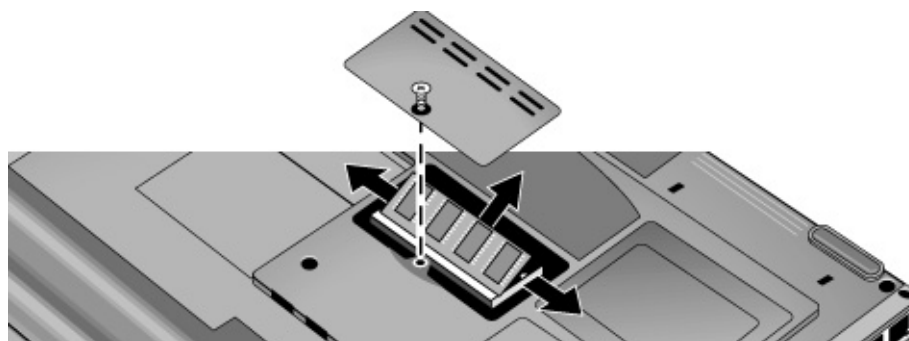

Figure 17. Removing an Expansion SDRAM Module

Reassembly Notes

- Carefully press the SDRAM module into the connector at an angle of about 30°, until it is fully inserted. Then press down on both sides of the module until the latches snap closed.

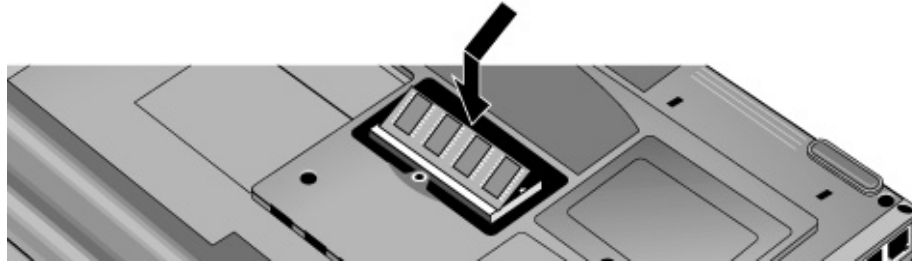

Figure 18. Installing an Expansion SDRAM Module

Removing the System SDRAM Module

Removal Procedure

1. Unplug the AC adapter, if present, and remove the battery.
2. Remove the keyboard cover (page 44).
3. Open the keyboard (page 48, steps 1 through 5). You don't need to disconnect the keyboard cable.
4. Press outward to release the latches at the sides of the SDRAM module (so that the free edge of the module pops up), then pull the module out of the connector.

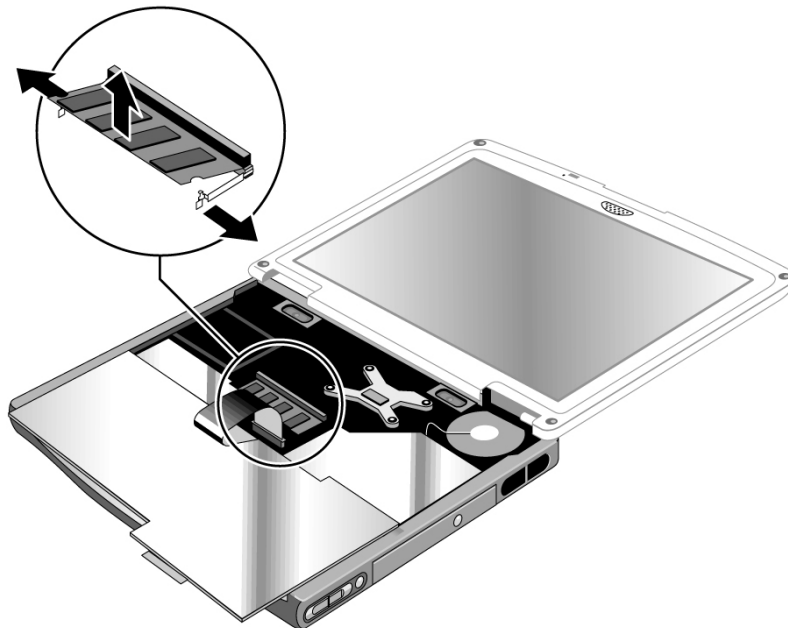

Figure 19. Removing the System SDRAM Module

Reassembly Notes

- Carefully press the SDRAM module into the connector at an angle of about 30°, until it is fully inserted. Then press down on both sides of the module until the latches snap closed.

Removing the Speakers

Table 8. Speaker Replacement Part Numbers

Description	Part Number	Exchange Part Number
Kit, speakers (L/R)	F3377-60942	

Required Equipment

- #0 Phillips screwdriver.

Removal Procedure

1. Unplug the AC adapter, if present, and remove the battery.
2. Remove these additional assemblies:
 - Keyboard cover (page 44).
 - Keyboard (page 48).
3. Remove the retaining screw from each speaker. Disconnect the speaker wires from the motherboard, and lift the speakers out of the notebook.

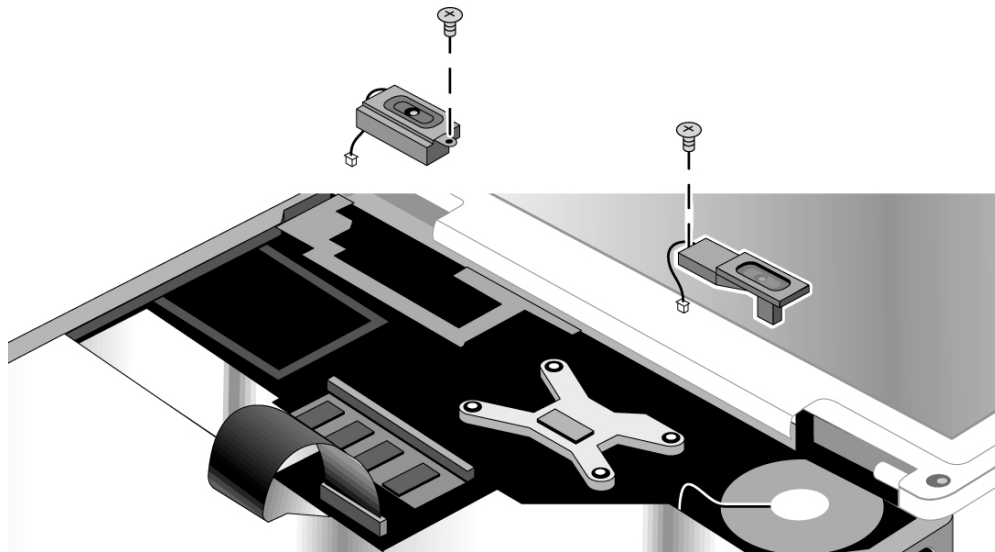

Figure 20. Removing the Speakers

Reassembly Notes

- Make sure the tabs on the left side (for the left speaker) or the right rear (for the right speaker) of the speaker fit between the corresponding tabs in the bottom case.
- Make sure the speaker wires fit through their notches in the bottom case, close to the speaker.

Removing the Fan

Table 9. Fan Replacement Part Numbers

Description	Part Number	Exchange Part Number
Fan, heatsink	F3377-60946	

Required Equipment

- #0 Phillips screwdriver.

Removal Procedure

1. Unplug the AC adapter, if present, and remove the battery.
2. Remove these additional assemblies:
 - Keyboard cover (page 44).
 - Keyboard (page 48).
 - Right speaker (page 52).
3. Disconnect the fan wires from the motherboard.
4. Remove both retaining screws from the fan.
5. Lift the fan out of the notebook.

Caution

Do not spin the fan blades with your finger, or you could damage the fan's bearings.

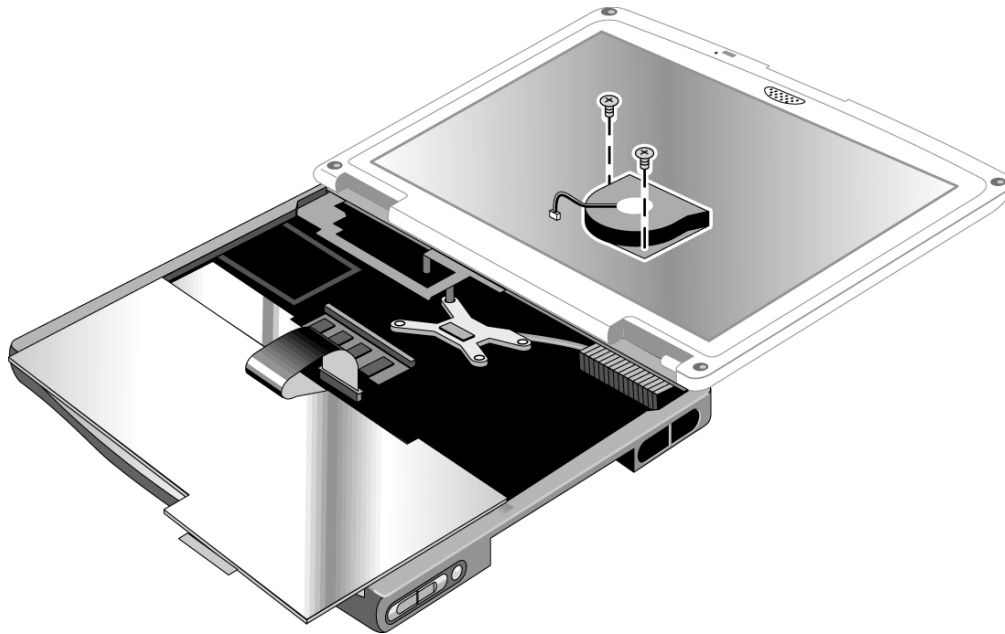

Figure 21. Removing the Fan

Reassembly Notes

- Make sure the fan wires are not pinned under the fan, and is securely plugged into its socket.
- If present, make sure the wireless cables are not trapped under or behind the fan.

Replacing Small Parts and Accessories

The following small parts are user-replaceable.

Table 10. Replacing Small Parts

Part	Part Numbers	Replacement Procedure
Cover, mini-PCI	Included in door kit F3377-60933	On the bottom of the notebook, loosen the screw in the mini-PCI cover (the cover retains the screw) and remove the cover.
Cover, expansion SDRAM	Included in door kit F3377-60933	On the bottom of the notebook, loosen the screw in the SDRAM module cover (the cover retains the screw) and remove the cover.
Covers, screw (on display bezel)	Included in feet/cover kit F3377-60967	Insert a small flat-blade screwdriver under the cover and pry it loose. To replace, firmly press the adhesive side of the cover into the recess.
Feet, rubber	Included in feet/cover kit F3377-60967	Insert a small flat-blade screwdriver under the foot and pry it loose. To replace, firmly press the adhesive side of the foot into the recess.

Table 11. Pavilion zt1100/xz100 and Omnibook xt1000 Series Accessories

Accessory	Description
New Accessories	
F3172A	Standard Lilon Battery
F3491A	CD-RW Upgrade Module
F3492A	DVD Upgrade Module
F3493A	CD-RW/DVD Combo Drive
F3494A	Simple Port Replicator
Tested Cross-Platform Accessories	
D9510B	USB Floppy Disk Drive Module
F1455A	Auto Air Adapter (75 W)
F1606A	Omnibook Ballistic Nylon Case
F1607A	Omnibook Leather Case
F1608A	Omnibook Executive Case
F1626B	3COM 10/100 Enet PC Card
F1645A	Kensington Lock
F1747A	Defcon Alarm
F1771A	Universal Carrying Case
F1778A	Promotional Carrying Case (NAM & AP)
F1778B	Standard Carrying Case (Europe Only)
F1781A	Ultra Slim Line Adapter (60 W)
F1782A	3COM Type II Combo Card
F2020A	Executive Leather Case (Europe only)
F2135B	Wireless Comm Access Point
F2135C	Wireless Comm Access Point
F2136B	Wireless PC Card (128 bits)
F2196A	3Com Bluetooth PC Card
F2297A	Car Adapter, 24 V (EU only)
F2298A	512 MB PC133 SDRAM
F3495A	128 MB PC133 SDRAM
F3496A	256 MB PC133 SDRAM
P1980A	USB Wireless LAN 802.11b
P1981A	USB Wireless LAN Access Point

Reference Information

This section includes information on HP's password removal policy, and on notebook display quality.

Password Removal Policy

If the user forgets the system password, the user calls HP Customer Care to determine the proper password removal procedure. The user must provide proof of ownership, and the notebook must be operated during the procedure.

The password removal procedure is protected as HP Company Private information. There are a restricted number of locations that can perform password removal. The procedure may not be disclosed or distributed outside those locations.

Password removal is strictly controlled. Hewlett-Packard and authorized support providers must ensure with written evidence that the notebook being "cleansed" is actually in the possession of the notebook's actual and current owner. This requires a sales receipt showing the notebook serial number and owner's name, or a written statement from the owner attesting that he or she is the owner of the notebook. The statement can be a fax copy of the document. The fact that the notebook is in the hands of an HP representative on behalf of the customer is not evidence of ownership. In addition, HP will not remove the password of a notebook for any non-owner, even if it is requested by law enforcement agencies. If you receive such a request, you should notify management and HP Corporate Legal immediately. (These requests may require a court order prior to our participation.)

Further, the entity removing the password must log the name, serial number, and date of the removal, and file the written backup with the log. The log and backup are subject to standard record retention process and review.

The final issue relating to removal of passwords is that HP cannot provide information to users that would assist them in improperly removing a password and opening a notebook.

Hewlett-Packard Display Quality Statement

TFT display manufacturing is a highly precise but imperfect technology, and manufacturers cannot produce large displays that are cosmetically perfect. Most, if not all, TFT displays exhibit some level of cosmetic imperfection. These cosmetic imperfections may be visible to the customer under varying display conditions, and can appear as bright, dim, or dark spots. *This issue is common across all vendors supplying TFT displays in their products and is not specific to the HP notebook display.*

HP notebook TFT displays meet or exceed all HP standards for cosmetic quality of TFT displays. HP does not warrant that the displays will be free of cosmetic imperfections. *TFT displays can have a small number of cosmetic imperfections and still conform to HP's cosmetic quality specifications.*

Here are some guidelines for determining what action to take on customers' complaints of cosmetic imperfections in their TFT displays:

1. View the notebook under the customer's normal operating conditions.

This means that if the customer uses the notebook predominately in DOS, in Windows, or in some other application or combination of applications, you should make the determination under those same applications. Self test is not a normal operating condition and is not a sufficient tool for interpreting display quality.

2. Use the table below to determine whether the display should be considered for replacement. These are the only conditions in this guideline that may call for a replacement due to a defect in material or workmanship based on the HP Limited Warranty Statement.
3. If a display is considered for replacement, make sure the customer understands that cosmetic variations may also exist on the replacement display, and may require the customer to use a work-around to obscure the cosmetic imperfection.
4. Displays with cosmetic imperfections that do not conform to the above conditions and tests will not normally be considered for display replacement. The HP-responsible person working with the customer should identify work-arounds that are reasonable and appropriate for that customer. Customers who require a more perfect display solution should consider switching to a notebook with a DSTN display.

We expect that over time the industry will continue to produce displays with fewer inherent cosmetic imperfections, and we will adjust our HP guidelines as these improvements are implemented.

Type of Imperfection	Imperfections Not Allowed
Electrical Imperfections: Bright dots (a) Dark dots (a)	<ul style="list-style-type: none"> • 7 or more single bright dots. • 7 or more single dark dots. • 9 or more total (bright and dark combined) defective dots. • Any occurrence of multiple defective dots within 15 mm.
Mechanical Imperfections: Discoloration Polarizer bubbles, dents (b)	<ul style="list-style-type: none"> • Any polarizer bubble, discoloration, or dent that is visible from at least 36 cm (14 in).
Definitions of imperfections: a A bright or dark dot is a subpixel (red, green, or blue dot) that is stuck on or off. b A polarizer dent or bubble is a light spot with a darker border that appears on a lighted display and does not change size. In contrast, a polarizer scratch is a light line that is visible on a darker background and does not change size.	