

Dell[®] Latitude[®] LT System User's Guide

Notice

Information in this manual is subject to change without notice and does not represent a commitment on the part of Dell Computer Corporation.

Dell Computer Corporation shall not be liable for technical or editorial errors or omissions contained herein; nor for incidental or consequential damages resulting from the furnishing, performance, or use of this material.

Dell strongly recommends that separate permanent written records be kept of all important data. Data may be lost or altered in virtually any electronic memory product under certain circumstances. Therefore, Dell assumes no responsibility for data lost or otherwise rendered unusable whether as a result of improper use, repairs, defects, battery replacement, use after the specified battery life has expired, or any other causes.

Dell Computer Corporation assumes no responsibility directly or indirectly, for financial losses or claims from third persons resulting from the use of this product and any of its functions, such as stolen credit card numbers, the loss of or alteration of stored data, etc.

Edition

1st Edition, November 1998.

Copyright

Information in this document is subject to change without notice.

© 1998 Dell Computer Corporation. All rights reserved.

Reproduction in any manner whatsoever without written permission of Dell Computer Corporation is strictly forbidden.

Trademarks

Dell, the *DELL logo*, and *Latitude* are registered trademarks and *DellWare* is a registered service mark of Dell Computer Corporation; *Pentium* is a registered trademark and *MMX* is a trademark of Intel Corporation; *MS-DOS* and *Windows* are registered trademarks of Microsoft Corporation; *UNIX* is a registered trademark of UNIX System Laboratories, Inc., a wholly owned subsidiary of Novell, Inc.; *ENERGY STAR* is a registered trademark of the U.S. Environmental Protection Agency. Other trademarks and trade names may be used in this document to refer to either the entities claiming the marks and names or their products. Dell disclaims proprietary interest in the marks and names of others.

Notice for Users in the USA

FCC Statement

WARNING: FCC Regulations state that any unauthorized changes or modifications to this equipment not expressly approved by the manufacturer could void the user's authority to operate this equipment.

Note: This equipment has been tested and found to comply with the limits for a Class B digital device pursuant to Part 15 of the FCC Rules.

These limits are designed to provide reasonable protection against harmful interference in a residential installation. This equipment generates, uses and can radiate radio frequency energy and, if not installed and used in accordance with the instructions, may cause harmful interference to radio communications. However, there is no guarantee that interference will not occur in a particular installation. If this equipment does cause harmful interference to radio or television reception, which can be determined by turning the equipment off and on, the user is encouraged to try to correct the interference by one or more of the following measures:

- Reorient or relocate the receiving antenna.
- Increase the distance between the equipment and receiver.
- Connect the equipment into an outlet on a circuit different from that to which the receiver is connected.
- Consult the dealer or an experienced radio/TV technician for help.

A shielded I/F cable and included cables with ferrite cores are required to ensure compliance with FCC regulations for Class B computing equipment.

As an ENERGY STAR® Partner, Dell Computer Corporation has determined that this product meets the ENERGY STAR® guidelines for energy efficiency.

Declaration of Conformity

Dell Latitude LT, PTP Series

This device complies with Part 15 of the FCC Rules. Operation is subject to the following conditions: (1) This device may not cause harmful interference, and (2) this device must accept any interference received, including interference that may cause undesired operation.

Responsible Party: Dell Computer Corporation
One Dell Way
Round Rock, Texas
512-338-4400

About the Modem

This equipment complies with Part 68 of FCC Rules. On the bottom of this equipment is a label that contains, among other information, the FCC registration number and ringer equivalence number (REN) for this equipment. If requested, this information must be provided to the telephone company.

The modem jack of this equipment complies with Sub-part F of Part 68 of FCC Rules.

The REN is used to determine the quantity of devices which may be connected to the telephone line. Excessive RENs on the telephone line may result in the devices not ringing in response to an incoming call. In most, but not all, areas the sum of the RENs should not exceed five (5.0). To be certain of the number of devices that may be connected to the line, as determined by the total RENs, contact the telephone company to determine the maximum REN for the calling areas.

If the terminal equipment causes harm to the telephone network, the telephone company will notify you in advance that temporary discontinuance of service may be required. But if advance notice isn't practical, the telephone company will notify the customer as soon as possible. Also, you will be advised of your right to file a complaint with the FCC if you believe it necessary.

The telephone company may make changes in its facilities, equipment, operations, or procedures that could affect the operation of the equipment. If this happens, the telephone company will provide advance notice in order for you to make the necessary modifications in order to maintain uninterrupted service.

If trouble is experienced with this equipment, please contact Dell Computer Corporation for repair and warranty information. If the trouble is causing harm to the telephone network, the telephone company may request you remove the equipment from the network until the problem is resolved.

The equipment cannot be used on public coin service provided by the telephone company. Connection to Party Line Service is subject to state tariffs. (Contact the state public utility commission, public service commission or corporation commission for information.)

The Telephone Consumer Protection Act of 1991 makes it unlawful for any person to use a computer or other electronic device, including fax machines, to send any message unless such message clearly contains, in a margin at the top or bottom of each transmitted page or on the first page of the transmission, the date and time it is sent and an identification of the business, or other entity, or other individual sending the message and the telephone number of the sending machine or such business, other entity or individual. (The telephone number provided may not be a 900 number or any other number for which charges exceed local or long-distance transmission charges.) To program this information, refer to the manual of the communication software.

CAUTION: Disconnect telephone lines before accessing the modem card.

Copyright

It is the intent of Dell Computer Corporation that this product be used in full compliance with the copyright laws of the United States and that prior permission be obtained from copyright owners whenever necessary.

Notice for Users in Canada

About the Modem

The Industry Canada label identifies certified equipment. This certification means that the equipment meets certain telecommunications network protective, operational and safety requirements. The department does not guarantee the equipment will operate to the user's satisfaction.

Before installing this equipment, users should ensure that it is permissible to be connected to the facilities of the local telecommunications company.

The equipment must also be installed using an acceptable method of connection. In some cases, the company's inside wiring associated with a single-line individual service may be extended by means of a certified connector assembly (telephone extension cord). The customer should be aware that compliance with the above conditions may not prevent degradation of service in some situations.

Repairs to certified equipment should be made by an authorized Canadian maintenance facility designated by the supplier. Any repairs or alterations made by the user to this equipment, or equipment malfunctions, may give the telecommunications company cause to request the user to disconnect the equipment.

Users should ensure for their own protection that the electrical ground connections of the power utility, telephone lines and internal metallic water pipe system, if present, are connected together. This precaution may be particularly important in rural areas.

CAUTION: Users should not attempt to make such connections themselves, but should contact the appropriate electric inspection authority, or electrician, as appropriate.

The **Ringer Equivalence Number** (REN) assigned to each terminal device denotes the percentage of the total load to be connected to a telephone loop which is used by the device. To prevent overloading, the termination on a loop may consist of any

combination of devices subject only to the requirement that the total Ringer Equivalence Number of all the devices does not exceed 5.

CAUTION: Disconnect telephone lines before accessing the modem card.

ATTENTION: Debrancher les lignes telephoniques avant d'enlever ce couvercle.

Notice for Users in the UK

IMPORTANT

The wires in this mains lead are coloured in accordance with the following code:

BLUE: Neutral

BROWN: Live

As the colours of the wires in the mains lead of this apparatus may not correspond with the coloured markings identifying the terminals in your plug proceed as follows.

The wire which is coloured **BLUE** must be connected to the terminal which is marked with the letter **N** or coloured black.

The wire which is coloured **BROWN** must be connected to the terminal which is marked with the letter **L** or coloured red.

This apparatus must be protected by a 3A fuse in the mains plug or distribution board.

Copyright

Recording and playback of any material may require consent, which Dell Computer Corporation is unable to give. Please refer particularly to the provisions of the Copyright Act 1956, the Dramatic and Musical Performers Protection Act 1958, the Performers Protection Acts 1963 and 1972 and to any subsequent statutory enactments and orders.

Notice for Users in Europe

This equipment complies with the requirements of Directives 89/336/EEC and 73/23/EEC as amended by 93/68/EEC.

Dieses Gerät entspricht den Anforderungen der EG-Richtlinien 89/336/EWG und 73/23/EWG mit Änderung 93/68/EWG.

Ce matériel répond aux exigences contenues dans les directives 89/336/CEE et 73/23/CEE modifiées par la directive 93/68/CEE.

Dit apparaat voldoet aan de eisen van de richtlijnen 89/336/EEG en 73/23/EEG, gewijzigd door 93/68/EEG.

Dette udstyr overholder kravene i direktiv nr. 89/336/EEC og 73/23/EEC med tillæg nr. 93/68/EEC.

Quest' apparecchio è conforme ai requisiti delle direttive 89/336/EEC e 73/23/EEC, come emendata dalla direttiva 93/68/EEC.

Η εγκατάσταση αυτή ανταποκρίνεται στις απαιτήσεις των οδηγιών της Ευρωπαϊκής Ένωσης 89/336/ΕΟΚ και 73/23/ΕΟΚ, όπως οι κανονισμοί αυτοί συμπληρώθηκαν από την οδηγία 93/68/ΕΟΚ.

Este equipamento obedece às exigências das directivas 89/336/CEE e 73/23/CEE, na sua versão corrigida pela directiva 93/68/CEE.

Este aparato satisface las exigencias de las Directivas 89/336/CEE y 73/23/CEE, modificadas por medio de la 93/68/CEE.

Denna utrustning uppfyller kraven enligt riktlinjerna 89/336/EEC och 73/23/EEC så som komplette ras av 93/68/EEC.

Dette produktet oppfyller betingelsene i direktivene 89/336/EEC og 73/23/EEC i endringen 93/68/EEC.

Tämä laite täyttää direktiivien 89/336/EEC ja 73/23/EEC vaatimukset, joita on muutettu direktiivillä 93/68/EEC.

CE Notice

Marking by the symbol **CE** indicates compliance of this Dell system to the EMC (Electromagnetic Compatibility) directive and the LVD (Low Voltage Directive) of the European Union. Such marking is indicative that this Dell system meets or exceeds the following technical standards:

- EN 55022 — “Limits and Methods of Measurement of Radio Interference Characteristics of Information Technology Equipment.”
- EN 50082-1:1992 — “Electromagnetic compatibility—Generic immunity standard Part 1: Residential, commercial, and light industry.”
- EN 60950: — “Safety of Information Technology Equipment.”

NOTE: *EN 55022 emissions requirements provide for two classifications:
Class A for typical commercial areas.
Class B for typical domestic areas.*

This Dell computer system/product is classified for use in a typical Class B domestic environment. A “Declaration of Conformity” in accordance with the preceding standards has been made and is on file at Dell Products Europe BV, Limerick, Ireland.

CAUTION:

To prevent electrical shock, disconnect the AC cord and the battery before servicing.

CAUTION:

FOR A COMPLETE ELECTRICAL DISCONNECTION, PULL OUT THE MAIN PLUG AND THE BATTERY.

VORSICHT:

UM DIE STROMZUFUHR VOLLSTÄNDIG ZU UNTERBRECHEN, DEN NETZSTECKER HERAUSZIEHEN UND DIE BATTERIE ÈNTFERNEN.

ATTENTION:

POUR UN ARRET TOTAL DU SYSTEME, DECONNECTEZ LA PRISE DE COURANT SECTEUR ET LA BATTERIE.

VARNING:

FÖR TOTAL ELEKTRISK URKOPPLING, KOPPLA UR KONTAKTEN OCH TA UR BATTERIET.

PRECAUCION:

PARA UNA COMPLETA DESCONEXION ELECTRICA DESENCHUFE LA CLAVIJA DE LA RED Y LA BATERIA.

Safety Precautions

General

- Follow all cautions and instructions which may be marked on the computer.
- Except as described elsewhere in this manual, refer all servicing to qualified personnel. Immediately shut off the computer and request servicing under the following conditions:
 - The power cord or plug is damaged or frayed.
 - Liquid has been spilled on the computer.
 - The computer has been dropped or the cabinet has been damaged.

Location

- Do not expose the computer to direct sunlight.
- Try to avoid dusty environments.
- Keep the computer away from any magnetic devices and TVs.
- Keep the computer away from excessive humidity or fluids such as rain, snow, water spray, juice, coffee, steam, etc.
- Do not move the computer from a cold place to a warm place. A temperature difference of more than 10°C (18°F) will cause condensation inside the unit, which may damage the data.
- Do not block or cover slots or openings on the cabinet to protect the computer from overheating.
- Do not smoke near your computer.

Usage

- Never push any objects of any kind into cabinet openings. They may touch dangerous voltage points or short parts that could result in fire or electrical shock.
- Turn off the computer before installing or removing a peripheral device (except when connecting USB devices and PC cards).
- Check the AC power cord and power connectors periodically for damage. Replace the power cord immediately if damage is found.
- Never subject your computer to sudden shocks or extreme vibration.
- Do not drop the computer or hit it with other equipment.

- Do not scratch the surface of the LCD screen.
- Turn off the computer and disconnect the AC power cord before cleaning.

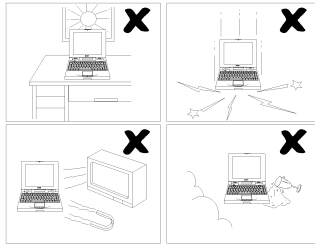

Battery Pack Precautions

Handling

- Never put the battery pack in a fire.
- Do not attempt to open or alter the battery pack.
- Do not place the battery where it might get hotter than 60°C (140°F).
- Do not allow metal objects such as jewelry to short across the battery terminals.
- Do not allow liquids to come in contact with the battery pack.
- Avoid dropping the pack or subjecting it to other violent shock.
- Do not solder anything to the battery terminals.

Charging

- Charge the battery pack only with the AC adapter included with your computer.

Discharging

- Do not use the battery pack for any purpose other than powering the computer.

Storage

- Store the battery pack in a cool and dry place. Never allow the temperature to exceed 60°C (140°F) during storage.
- Recharge the battery pack after storage, before use.

Modem Precautions

- Never install telephone wiring during a lightning storm.
- Never install telephone jacks in wet locations unless the jack is specifically designed for wet locations.
- Never touch uninsulated telephone wires or terminals unless the telephone line has been disconnected at the network interface.
- Use caution when installing or modifying telephone lines.
- Avoid using the telephone during a lightning storm. There may be a remote risk of electric shock from lightning.
- Do not use the telephone to report a gas leak in the vicinity of the leak.

Recording Important Information

For future reference, please record the following information in the spaces provided below.

Model Number:

Serial Number:

Date of purchase:

Dealer's Name:

Place of purchase:

Password:

The serial number is printed on a sticker located on the bottom of the computer.

Manual Conventions

This manual uses a set of style conventions described below.

Notes and Cautions are italicized with icons:



A note icon informs you of a special technique or information that may help you perform a task or better understand a process.



A caution icon alerts you to something that may cause problems or damage to hardware, software or data.

Key Labels on the Keyboard, when referred to in the instructions, are shown in boldface:

Press **Enter** to continue.

When more than one key is pressed simultaneously, the key labels are separated by a plus (+) sign:

Restart your computer by pressing **Ctrl+Alt+Delete**.

When necessary, important key combinations are shown in graphics:



Sample Entries are shown in upper cases of a different typeface. In the following case, press the Enter key after you type the command:

C:\>DIR A: **Enter**

Words/Texts on Screen, such as window titles or possible parameters, are italicized:

Double-click this icon to display the *Power Properties* window.

Set the item to *Enabled*.

Screens reproduced in this manual may differ slightly from the screens you see on your computer.

Section Titles in other parts of this manual are italicized:

Refer to the *Infrared Communication* section in Chapter 5.

Overview of Computer

Actual appearance of your computer may be slightly different depending on the model.

Front

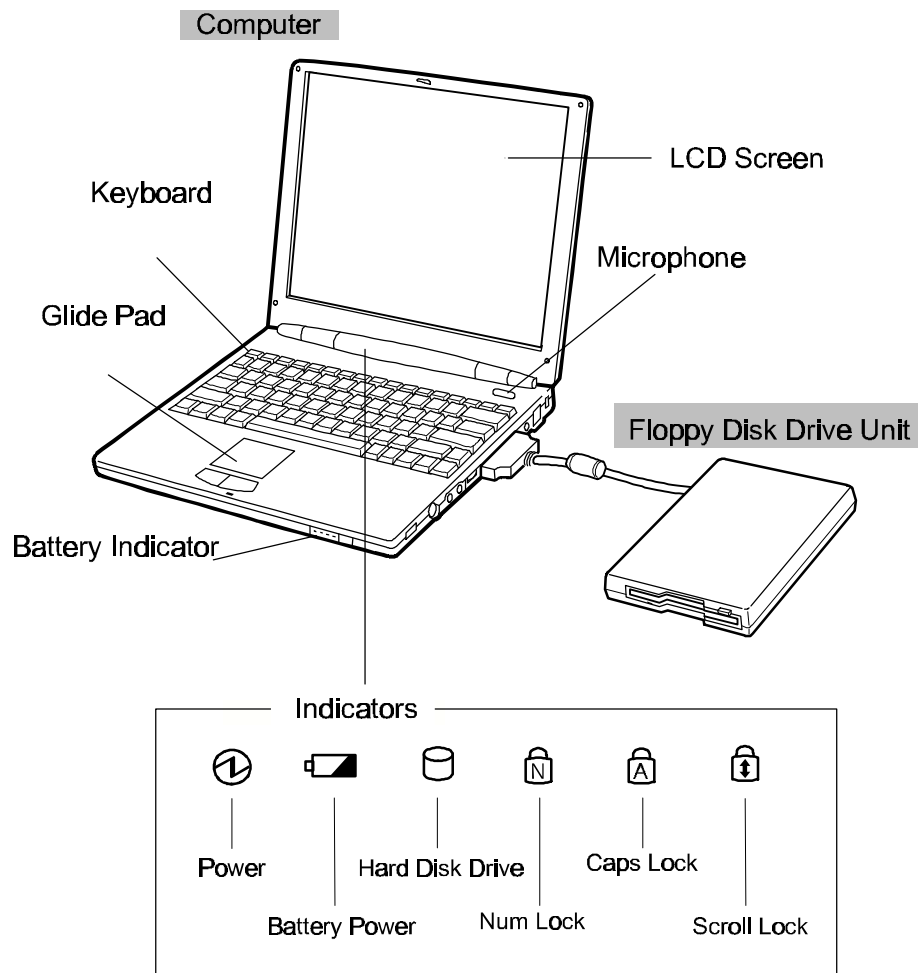

Right

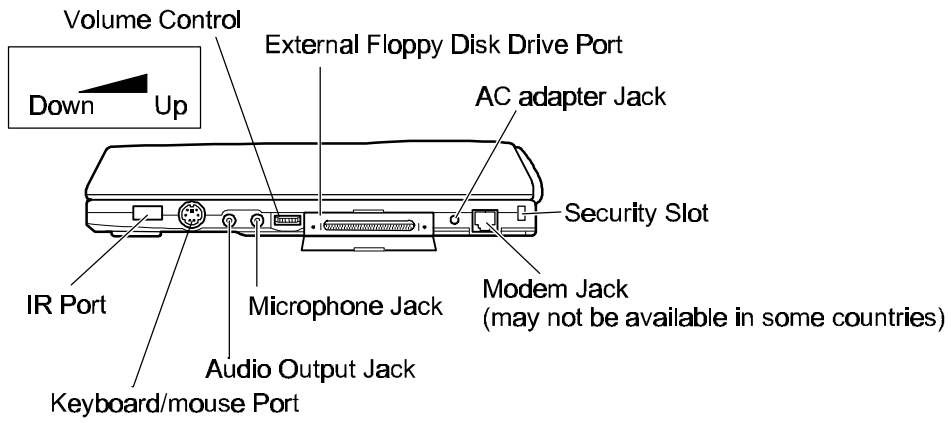

Left

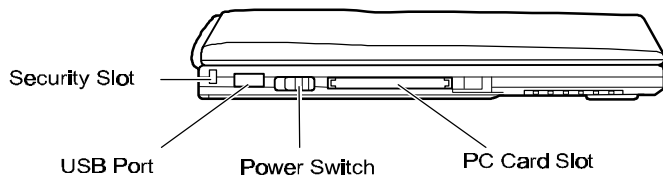

Rear

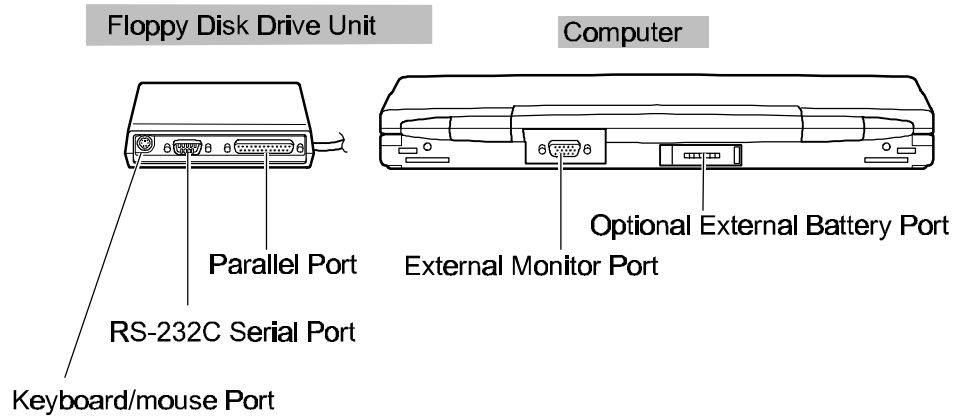

Bottom

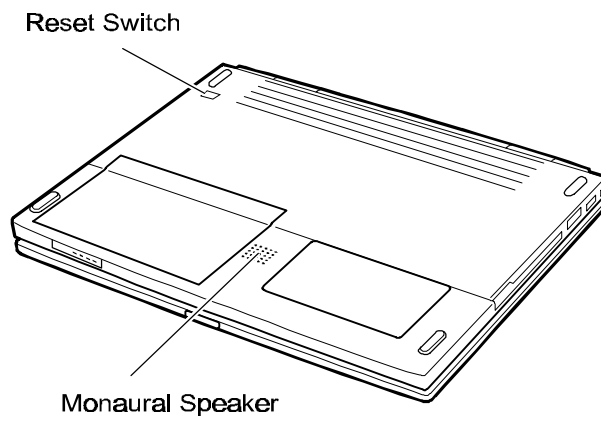

Table of Contents

Quick Setup	1-1
Turning Power On	1-1
Setting Up the Windows Operating System.....	1-3
Shutting Down the System.....	1-4
Basic Operations	2-1
Choosing Power Source	2-1
Resetting the System	2-2
Using the Glide Pad.....	2-3
Using the Keyboard	2-5
Using External Floppy Disk Drive Unit.....	2-6
Battery and Power Management	3-1
Standard Battery Pack.....	3-1
Optional External Battery Pack.....	3-5
Disposing of the Battery.....	3-7
Power Management.....	3-8
Peripherals	4-1
Using Peripherals	4-1
PC Card	4-3
Keyboard/Mouse	4-5
Display	4-6
Audio System	4-8
USB Device.....	4-9
Printer	4-9
RS-232C Device.....	4-10
Communication Functions	5-1
Infrared Communication.....	5-1
Built-in Modem (not available in some countries)	5-3

Security Features	6-1
Passwords	6-1
Security Slot.....	6-4
Setup Utility	7-1
Running the Setup Utility	7-1
Main Menu	7-3
Advanced Menu	7-4
Security Menu	7-5
Power Menu.....	7-6
Exit Menu.....	7-7
Getting Help	8-1
Help Tools.....	8-1
Contacting Dell.....	8-5
Maintenance and Specifications	A-1
Maintenance.....	A-1
Specifications.....	A-3
Options	A-4
Troubleshooting	B-1
Warranty, Return Policy, and Year 2000 Statement of Compliance	C-1
Limited One-Year Warranty (U.S. and Canada Only).....	C-1
“Total Satisfaction” Return Policy (U.S. and Canada Only)	C-3
Year 2000 Statement of Compliance for Dell-Branded Hardware Products.....	C-4

CHAPTER 1

Quick Setup

Your computer is designed and pre-configured for easy setup and use. This chapter describes the steps to get your computer up and running as quickly as possible. Read this chapter first.

Turning Power On

Your computer is powered with either the rechargeable battery or AC power. See the next chapter for more information on power sources. Before using the computer for the first time:

1. Remove the battery protection sheet on the bottom of the computer.



If you do not remove the sheet, you cannot turn on the computer.

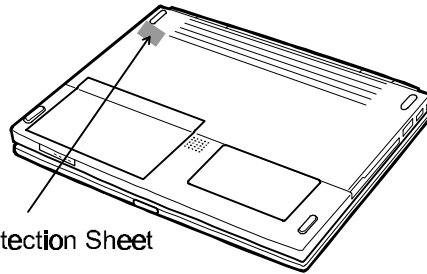

Battery Protection Sheet

2. Plug the AC adapter cable into the computer's AC adapter jack.
3. Plug the AC power cord into the AC adapter.



- *Always use the AC adapter included with the computer. Using other AC adapters may damage the computer.*
- *Always hold the AC power cord by its plug when removing it from the wall outlet. Never pull on the cord.*
- *When using the computer for the first time, be sure to connect it to AC power. If using the battery instead, you may not be able to complete the operating system setup if the battery does not have enough power.*

4. Plug the AC power cord into a wall outlet.

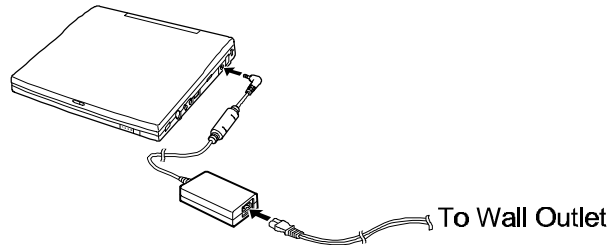

5. Slide the display lock latch until the screen cover releases, and raise the cover.
6. Tilt the cover to a comfortable viewing position.

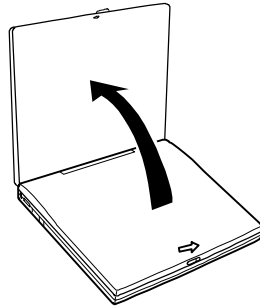

7. Slide the power switch to the rear and release it.

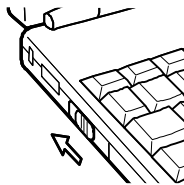

When you turn on the computer, the power indicator () turns green, the computer goes through a self test to detect any problems, and the operating system starts. When you use the computer for the first time, a dialog box called *Setup Wizard* appears to guide you through the operating system setup.

Setting Up the Windows® Operating System

The first steps in the setup process are as follows:

- Gathering information
- Configuring your computer
- Restarting your computer

To set up the operating system, follow the instructions on the screen. See also the operating system manual. It takes approximately 5-10 minutes to complete the entire setup process.



Do not turn off the computer until completing the operating system setup. If you turn off the computer, you cannot set it up later.

Properties Dialog Box in Windows

In the instructions in this manual, you will often see the expression XXX Properties dialog box. A dialog box is a window containing text boxes, check boxes, buttons, etc. with which you can send commands to the operating system or other application programs. To open the properties dialog boxes, click the *Start* button, select *Settings - Control Panel* and double-click the XXX icon. Among the dialog boxes you often use are:

- Display
- Modems
- Mouse
- PC Card
- Power Management
- System

Shutting Down the System



- *Do not turn off the computer by sliding the power switch. Data may be lost or damaged.*
 - *Do not turn off or reset the computer while the hard disk indicator or the indicator on the external floppy disk drive unit or optional external CD-ROM drive is lit. Doing so may damage or even wipe out the data.*
 - *To protect the screen, always close the screen cover while the computer is off.*
 - *Wait at least 5 seconds after turning off the computer before turning it back on. Turning the power off and on in rapid succession can damage the computer's electrical circuitry.*
-

To turn off the computer:

1. From the *Start* menu, select *Shut Down*.
2. Select *Shut Down* and click *OK*. The computer turns off automatically.



If you have not saved a file, a dialog box will appear asking whether you want to save it.

CHAPTER 2

Basic Operations

This chapter describes the basic operations of your computer.



Choosing Power Source

You can use the computer with one of the following power sources:

- AC power from a wall outlet
Use AC power whenever possible; rely on the battery only when AC power is not available.
- Rechargeable battery
There is an internal standard battery in the computer. You can use an optional external battery pack to add to the operating time on battery power. See Chapter 3 for battery information.

About the Power Indicators

The following indicators show the power status of your computer.

Indicator	Light	Meaning
Battery Power 	On (green)	Fully charged
	On (orange)	Being charged
	Blinking (orange)	In abnormal state
	On and blinking (red)	Almost completely discharged. The warning beep sounds.
Power 	On (green)	Operating
	Blinking (green)	Suspended to RAM
	Off	Suspended to Disk or powered off



For more information on Suspend to RAM and Suspend to Disk, see Chapter 3.

Using the AC Adapter

When connected to a wall outlet, the AC adapter provides power for operation and charges the battery. The AC input voltage can range from 100 to 240 volts so that you can use the computer with the appropriate plug adapter.



The AC power cord included with the computer is appropriate for the voltage used in the area in which you purchased your computer. If you attempt to connect the computer to a wall outlet other than in this area, check the voltage of the outlet and use an AC power cord appropriate for the outlet. Consult local service staff if you are unsure.

Resetting the System

You may need to reset the system after adding hardware or software so that your computer will recognize the newly installed devices or software. When the message appears after the installation, click *OK*, *Yes*, etc. to restart the operating system. You can also restart the operating system from the *Start* menu. Select *Shut down* then *Restart*.

Warm Boot



Resetting may cause data loss. Use the software reset only if the normal Shut Down does not work because of software malfunction. Although resetting will not damage the system, you may lose the data you are processing.

If the system is locked up because of a software problem, you can reset or reboot the system by pressing the **Ctrl+Alt+Del** keys simultaneously. Press the **Ctrl+Alt+Del** keys again to restart the computer.

Power Switch

You can turn off the computer with the power switch if you encounter hardware or software problems which lock up the system. In this case, slide and hold the switch for more than 5 seconds.

Reset Switch



Do not use metallic materials to slide the reset switch. Doing so may cause malfunction.

If you cannot turn off the computer by sliding the power switch, you can use the reset switch on the bottom of your computer. To reset the system, insert a narrow object into the small hole to slide the switch as shown.

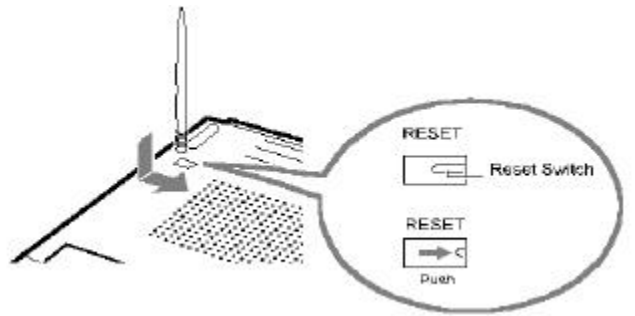

Using the Glide Pad

Your computer is equipped with an integrated pointing device called a glide pad. Using the glide pad, you can move the pointer, select an item from a menu, and perform other tasks in the same way you would with a mouse.



- Do not hit or scratch the surface of the glide pad with pointed objects (such as a ballpoint pen).
- Do not operate the glide pad with a moist finger. This may cause the glide pad to operate incorrectly.
- You cannot use the glide pad when a mouse is connected.

Using the Glide Pad

Take a moment to become familiar with how the glide pad works.

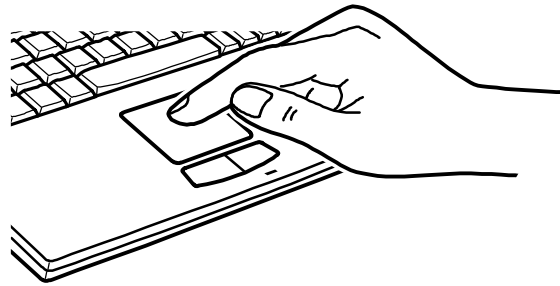

Place Your Fingertip

Place your left or right hand next to the glide pad, resting your wrist naturally in a relaxed manner. Place your thumb or finger on the glide pad.

Move Your Fingertip

The rectangular pad of the glide pad acts like a miniature duplicate of the display. As you slide your fingertip across the pad, the pointer on the screen moves in the same direction across the screen. The glide pad is very sensitive, so you do not have to exert a lot of pressure on the pad. The glide pad will respond to a light touch from your fingertip.

Click, Double-click, and Right-click

To click or double-click, you can use the left button just like that of a mouse. Instead of clicking by pressing the left button, you can just tap gently anywhere on the rectangular pad. For right-clicking, you can use the right button.

Drag and Drop

You can move icons or windows by using “drag and drop” as follows:

1. Position the pointer over the object.
2. Press the left button; do not release it.
3. Holding down the button, move the pointer. The object moves together with the pointer.
4. Release the button when the object reaches its destination.

Scroll

You can scroll through information in a list or in a document by using the glide pad. Place your finger on the right part of the glide pad and move it back and forth. This procedure works only in some applications.

Changing the Configuration

In the *Mouse Properties* dialog box, you can change the configuration of the glide pad, such as swapping left and right buttons, changing the pointer size, etc.



- If you swap the left and right buttons, "tapping" on the glide pad as an alternative method of pressing the left button will no longer function.
- If you prefer to use a mouse and turn off the glide pad, you can disable the glide pad in the Setup Utility. See also Chapter 4.

Using the Keyboard

Your computer, equipped with the Windows Enhanced Keyboard, provides all the functionality of a full-sized desktop keyboard.

Windows Logo Keys



Opens the Windows Start menu.



Opens an application-specific short-cut menu equivalent to right-clicking.

System Function Keys

When pressed together with the **Fn** key, function keys set specific system parameters. This combination is sometimes referred to as "hot keys."



Switches the display output between the LCD screen and external monitor (if connected). See the *Display* section in Chapter 4 for details.



Decreases the LCD screen brightness.

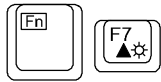

Increases the LCD screen brightness.



Turns the screen backlight on and off.



Puts the computer in suspend mode (to RAM or to Disk, according to the setup selection). See also Chapter 3.

Using External Floppy Disk Drive Unit

You can use double-density (2DD) 720KB or high-density (2HD) 1.44MB floppy disks with the external floppy disk drive unit.

The keyboard/mouse port, RS-232C serial port and parallel port are available on the rear side of the floppy disk drive unit. You can connect peripherals to the floppy disk drive unit. For more information about peripherals, refer to Chapter 4.

Connecting External Floppy Disk Drive Unit



Turn off the computer before connecting the external floppy disk drive unit; otherwise the floppy disk drive unit may not be recognized.



- Do not place the floppy disk drive unit on its side or upside down.
- Do not press on the floppy disk drive unit. It may damage the drive or cause malfunction.
- Do not place the AC adapter on the floppy disk drive. It may cause the drive to malfunction.

-
1. Turn off the computer.
 2. Open the cover of the external floppy disk drive port on the right side of the computer.

3. Connect the connector of the floppy disk drive unit to the floppy disk drive port.

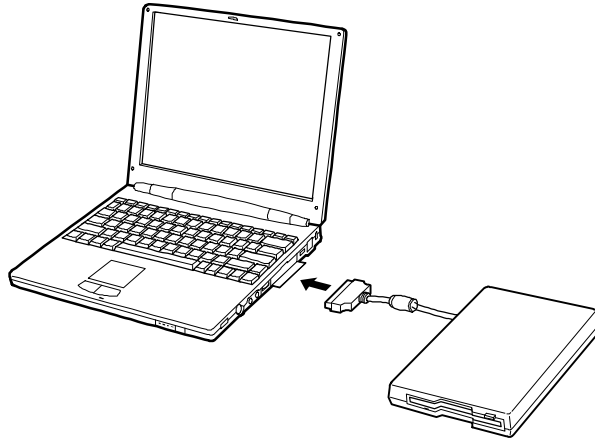

Removing External Floppy Disk Drive Unit

1. Remove the floppy disk from the floppy disk drive.
2. Turn off the computer.
3. Disconnect the floppy disk drive unit by simultaneously pressing the buttons on each side of the connector and pulling it out.
4. Close the cover of the floppy disk drive port.

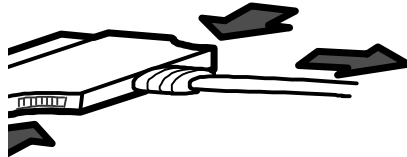

Handling Floppy Disks

- Do not open the shutter and touch the disk inside; otherwise, you will not be able to read or write data to the disk.
- Do not place floppy disks near magnets or heat sources, in direct sunlight or in a dusty place.
- Never subject a disk to sudden shocks or extreme vibration. Do not drop, bend, or place heavy objects on a disk.
- Do not spill liquid onto a disk.

Inserting and Removing a Floppy Disk

Inserting



- Always insert a floppy disk straight into the computer.
- When inserting the disk, make sure it is not upside down.
- Do not use excessive force when inserting the floppy disk. If you have difficulty inserting or removing disks, seek the assistance of an authorized service technician.

Hold the floppy disk with the arrow facing up and toward the drive. Slide the disk into the drive until it locks into place.

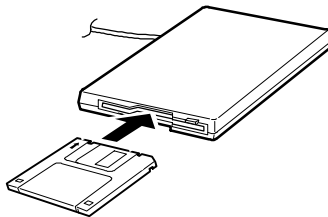

Removing



Before removing the floppy disk, make sure the indicator of the floppy disk drive unit is not lit.

Press the eject button firmly. The disk will pop out slightly. Remove it and store it properly.

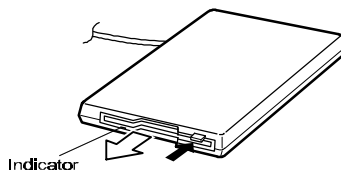

Formatting a Floppy Disk



When you format a floppy disk, all data previously stored on the disk is lost.

1. Make sure the floppy disk is not write-protected, and insert it into the floppy disk drive.
2. Double-click *My Computer* on the desktop.
3. Click *3 1/2 Floppy [A:]*. From the *File* menu, select *Format*.
4. From the capacity drop-down list, select 1.44MB or 720KB.
5. Click *Start* to start formatting.

Backing Up Data

Dell recommends that you regularly back up the data on your hard disk drive. The Windows operating system has a backup function you can use to back up your data. See the online Help for details.

CHAPTER 3

Battery and Power Management

This chapter explains how to manage the computer's power effectively and use the standard battery or an optional battery pack.

Standard Battery Pack

When not connected to an external power source, your computer operates with the rechargeable internal standard battery pack. The duration of the battery life may be longer if the computer's power management is active. See the *Power Management* section in this chapter for information about power management.

To keep the battery life long:

- Use the procedure in the *Initialize the Battery Pack* section in this chapter if the actual remaining power in your battery is less than what the battery indicator lights suggest.
- Turn off your computer when you are not using it.



- *The duration a battery charge will last will depend on the computer usage. Heavy use the peripherals, like the external floppy disk drive unit or the optional external CD-ROM drive, will result in shorter power duration.*
 - *When the battery is not charged, your computer may not operate properly. Connect the AC power to charge the battery.*
 - *If you see an error message during booting, press **F2** to open the Setup Utility. Following the instructions in Chapter 7, adjust the Setup Utility and restart the system.*
 - *When using the computer for several hours with battery packs, enable power management and set the suspend-to-disk mode. Refer to the Power Management section in this chapter and the Power Menu section in Chapter 7.*
-



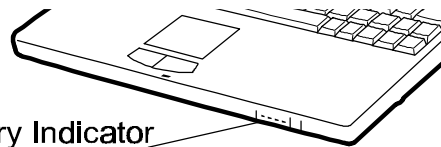

Checking the Battery Level

You can check the battery level in the *Power Management* properties dialog box in the Control Panel or by double-clicking the battery or AC plug icon on the taskbar.

You can also check the battery indicator on the front side of the computer.



Press the button on the right of the battery indicator to show the battery power remaining. Refer to the table below.

Battery Indicator Status	Capacity Remaining
 (All on)	76%-100%
 (Three on)	51%-75%
 (Two on)	26%-50%
 (One on)	1%-25%
 (All off)	0% (Empty)

This battery indicator turns on automatically while the battery is being charged (when connected to AC power). When the battery is fully charged, the battery indicator turns off.



The battery power remaining is an approximate figure. The remaining operating time expected may be different from the actual remaining time, depending on the use of the computer. If the actual remaining power in your battery is less than what the battery indicator lights suggest, you should initialize the battery pack. See Initializing the Battery Pack later in this chapter.

Low Battery Indication

When the battery power becomes significantly low, the battery power indicator () turns red and the warning beep sounds. Save your data and turn off the computer, or connect the computer to a wall outlet immediately. The computer will suspend data to disk when there is significantly low battery power. You can adjust this activity in the *Power* menu of the Setup Utility. When your computer suspends, do not turn on the computer before connecting it to a wall outlet or connecting a fully charged optional external battery pack.

In the Windows operating system, you can set the alarm to inform you of the remaining battery level. In the *Power Management properties* dialog box, select the *Alarms* tab and set *Low battery alarm* and *Critical battery alarm*.

The remaining operating time depends on the power you are consuming. If you are using the audio system, PC card slot, hard disk drive or external floppy disk drive unit, your computer may consume more battery life.



See also the section on power management in this chapter.

Charging the Battery Pack

1. Connect the AC adapter to the computer. While the battery is being charged, the battery power indicator is orange and the battery indicator turns on.
2. When the battery is fully charged, the battery power indicator turns green and the battery indicator turns off. Charging time may vary according to the status of the computer.



When the battery is hot (for example, after long use), it may take longer to fully charge the battery.

Initializing the Battery Pack

You need to initialize the battery pack when the actual remaining power in your battery is less than what the battery indicator lights suggest.

1. Connect the computer to AC power and wait until the battery is fully charged. The battery power indicator turns green and the battery indicator turns off. It will take about 2 hours and 30 minutes if the battery is completely discharged.

2. Turn on the computer.
3. When the message *Press <F2> to enter Setup Utility* appears, press **F2** to open the Setup Utility.
4. Disable the power management and set *Critical Battery Suspend* to *Disabled* in the *Power* menu of the Setup Utility. See *Disabling Power Management* in this chapter and *Power Menu* in Chapter 7.
5. Press **Esc**; then **Enter** twice. The system restarts.
6. When the message *Press <F2> to enter Setup Utility* appears, press **F2** to open the Setup Utility. Leave the computer in the Setup Utility.
7. Disconnect the AC adapter, and leave the computer until the battery is completely discharged and the system shuts down automatically. It will take about 3 hours.
8. Connect the computer to the AC adapter and let the battery fully charge.



- *Do not connect the computer to a wall outlet while discharging the battery. The initialization will be cancelled.*
 - *You can initialize the standard battery alone only if the optional external battery pack is disconnected. When the external battery pack is connected, both the standard and the external battery will be initialized together.*
-

Changing the Battery Pack

The capacity of a battery pack gradually decreases when used repeatedly (the deterioration rate depends on the operating temperature and environment). If the battery life becomes extremely short even after the initialization, you should change the standard battery pack. Contact your local Dell Service Representative to replace the standard battery pack.



Never replace the standard battery pack by yourself.

Optional External Battery Pack

You can use an optional external battery pack to power your computer for longer periods of time.



Use only the appropriate optional external battery pack, and attach it correctly.

Connecting External Battery Pack

1. Slide the cover of the external battery port to locate the port.

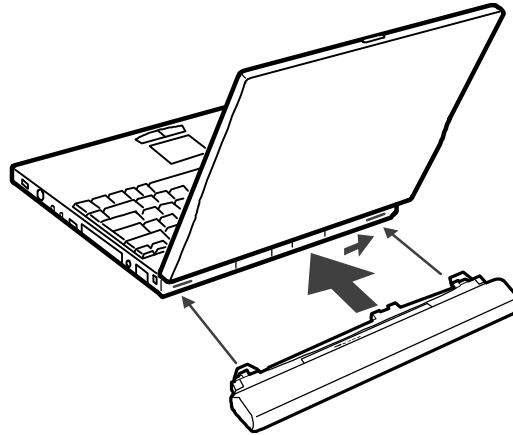

2. Connect the optional battery by matching the projections on either side of the battery to the notched parts of the computer. Make sure that the battery connector lines up with the external battery port of the computer. If you hear a clicking sound, the external battery pack is correctly connected.



- *While the external battery pack is connected, do not carry the computer by holding the computer only. Firmly hold both the computer and the external battery pack.*
 - *You cannot connect an external monitor when the external battery pack is connected.*
-

Removing External Battery Pack



Before removing the external battery pack, turn off the computer or confirm that the standard battery pack has power remaining. If the standard battery pack has no power remaining, connect the computer to AC power; otherwise the computer will be shut down and data may be lost.

Remove the optional battery by pressing the buttons on each end of the battery and sliding the battery off the computer.

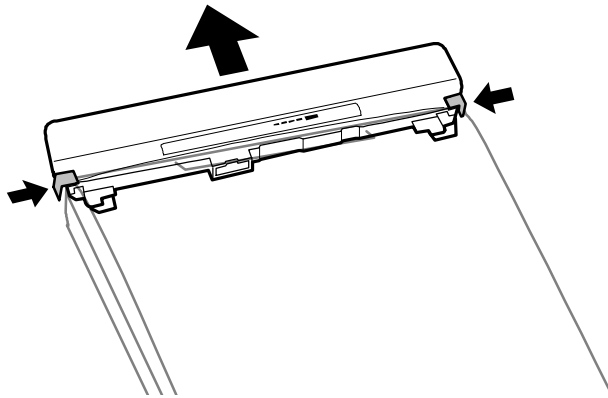

Close the cover of the external battery port after the external battery pack is removed.

Checking the Battery Level

You can check the battery level of the external battery pack (in the same way as the standard battery pack) with the battery indicator. Press the button on the right of the indicator. The status of the indicator is the same as that of the standard battery. See *Checking the Battery Level* under *Standard Battery Pack* earlier in this chapter.

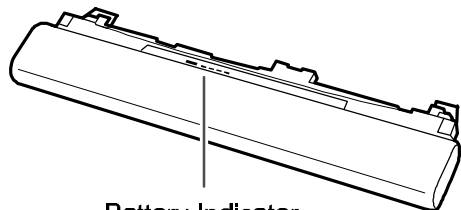

Battery Indicator

Charging External Battery Pack

You can charge the external battery pack by connecting AC power to the computer with the external battery connected. To charge most effectively, the standard and external battery pack should be charged as follows:

1. Charge standard battery pack to 80%.
2. Charge external battery pack to 80%.
3. Charge standard battery pack remaining 20%.
4. Charge external battery pack remaining 20%.

When the computer is turned off or in the suspend-to-disk mode, it will take about 5 hours and 30 minutes to charge both the standard and external battery packs from empty to full. When the computer is turned on, it will take about 7 hours and 30 minutes. (The charging time depends on the power you are consuming.)

Initializing External Battery Pack

The procedure for initializing an external battery pack is the same as that of the standard battery. But, you cannot initialize the external battery pack only. If you begin the initializing process, both standard and external battery packs will be initialized.

Disposing of the Battery



This computer contains or is supplied with a lithium-ion battery. Lithium-ion batteries are longer life batteries than other conventional battery chemistries and do not require replacement as often. The internal battery must be replaced by a Dell service representative, and the external battery may be replaced with a Dell-provided replacement. Spent batteries should not be placed in common household waste. Contact local authorities for the location of a chemical waste collection program nearest you.

Power Management

Power management saves electricity and extends battery life by controlling power supply to built-in devices. You can set the power management properties in the Setup Utility. The default properties are optimized for maximum battery life under normal operating conditions.



Note that power management may not seem to function in the following conditions:

- *When you are using an application program that accesses the hard disk periodically*
- *When the IR monitor is available (refer to Chapter 5)*
- *When Windows CD Auto Play is functioning*

Stopping Power Supply to the Hard Disk

Setting in the Setup Utility

In the *Power* menu, set *Power Management Function* to *Enabled* and set *Hard Disk Power Down after* to an appropriate value.

Stopping Power Supply to the Display



This procedure is also effective for an attached external monitor complying with power management.

Setting in the Setup Utility

In the *Power* menu, set *Power Management Function* to *Enabled* and set *Video Power Down after* to an appropriate value.

Suspend Modes

The power management feature contains two types of suspend modes: suspend-to-RAM mode and suspend-to-disk mode. In the Setup Utility, you can define which suspend mode the system enters in what conditions.

- Suspend-to-RAM mode stores the current condition of the computer in RAM and stops power supply to all but a few essential components. Your system enters and resumes from the suspend-to-RAM mode per the conditions mentioned below. In the suspend-to-RAM mode, the Power indicator blinks green.
- Suspend-to-disk mode saves the current condition of the computer in an area of the hard disk, which is called "suspend-to-disk partition," and turns off the computer. Your system enters and resumes from the suspend-to-disk mode per the conditions mentioned below. In the suspend-to-disk mode, the Power indicator turns off.

Before Suspending the System

Finish communications, printing and playing music or video before suspending the system.

Entering the Suspend Modes

Your computer enters a suspend mode in each of the following cases. Set *Suspend Mode* in the *Power* menu of the Setup Utility to trigger the suspend mode under the following circumstances:

- You slide the power switch when the item *Power Switch Function* is set to *Suspend/Resume* in the Setup Utility.
- You press **Fn+F12**.
- The specified time in *System Standby* of the *Power Management Properties* dialog box has passed without any operation.

Set *Cover Close* in the *Power* menu of the Setup Utility to trigger the suspend mode under the following circumstance:

- The screen cover is closed.

Set *Critical Battery Suspend to Enabled* in the *Power* menu of the Setup Utility to trigger the suspend mode under the following circumstance:

- The battery level is low (always suspended to disk).

Resuming From Suspend-to-RAM Mode

Your computer resumes from the suspend-to-RAM mode in each of the following cases:

- You press any key.
- The screen cover is opened.
- The built-in modem receives a call if *Resume On Modem Ring* in the *Power* menu of the Setup Utility is set to *Enabled* (the built-in modem may not be available in some countries).
- You slide the power switch when the item *Power Switch Function* is set as *Suspend/Resume* in the Setup Utility.

Resuming From Suspend-to-Disk Mode

Your computer resumes from the suspend-to-disk mode when you slide the power switch. The system restores the exact state as it was when entering the suspend mode. If the computer enters the suspend mode because of low battery power, however, you have to connect the computer to AC power first. Suspend-to-disk mode is useful when you want to turn off the computer and reopen the same windows after turning it on.



- *If your battery becomes completely discharged while in suspend-to-RAM mode, you will lose unsaved data and will need to reboot your computer. Therefore, if you are planning to leave your computer suspended for long periods of time, Dell recommends using suspend-to-disk mode.*
- *When the system enters or resumes from the suspend-to-disk mode, you can see some flicker on the display. This is not a malfunction.*
- *If sufficient battery power does not remain, your computer will not resume from the suspend-to-disk mode. To resume it from the suspend-to-disk mode, connect the computer to AC power.*
- *If a PC card does not work properly after your computer resumes from the suspend-to-disk mode, restart the computer.*



When entering or resuming from a suspend mode, be sure to observe the following precautions. Otherwise, the computer may not operate correctly after it has resumed from the suspend mode.

- *Do not turn off the computer when the system is suspended to RAM. The RAM contents will be lost.*
 - *Do not operate the keyboard, glide pad or mouse while the system is entering or resuming from a suspend mode.*
-

Disabling Power Management

In the Setup Utility

1. In the *Power* menu, set *Power Management Function* to *Enabled*.
2. Set *Hard Disk Power Down after*, *Video Power Down after* and *Auto Suspend* to *Disabled*.
3. Set *Power Management Function* to *Disabled*.



When you are using communication software or if sound or voice pauses or skips while played back, disable power management.

CHAPTER 4

Peripherals

This chapter describes how to use peripheral devices with your computer. You can connect a printer, external monitor, external keyboard, mouse or other device to the parallel, RS-232C serial, USB or keyboard/mouse ports. To ensure proper use, be sure to read the instructions for each peripheral device before connecting it to your computer.

Using Peripherals

You can use the peripheral devices shown under *Peripherals Connection Overview*. For details, refer to the section in this chapter that explains the device.



- *Be sure to turn off the computer and the peripheral device before connecting a device (except when connecting USB devices and PC cards).*
- *Some devices have to be turned on after the computer is turned on.*
- *Some devices require that you install drivers before use.*

Connecting a Peripheral Device

1. Turn off the computer and the peripheral device (except when connecting USB devices and PC cards).
2. Connect the peripheral device to the computer. If the connector has screws, tighten them.
3. Turn on the peripheral device; then, turn on the computer.

Peripheral Connection Overview

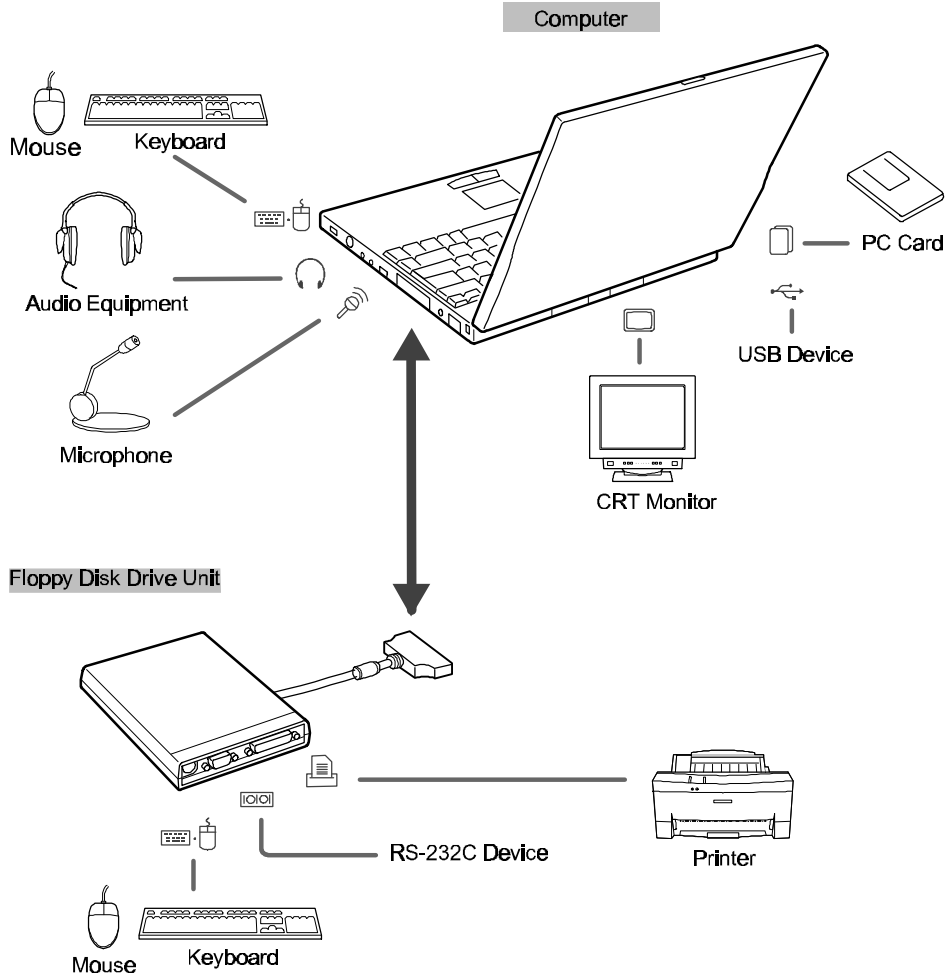

PC Card

Your computer is equipped with a PC card (PCMCIA) slot, which can accommodate one Type II card. Before inserting a PC card into your computer, see its manual.

When using a PC card which needs an IRQ, disable one of the following ports: Serial, IR, LPT, Modem, or Sound. Otherwise a PC card or the computer may malfunction.



Never disable the USB port. Disabling the USB port in the Setup Utility may cause some PC cards to malfunction.

Inserting a PC Card

1. Raise the PC card eject button and push it in. The protection card pops out.
2. Remove the protection card from the PC card slot.
3. Insert the card into the slot with the label face up until it locks into place. The PC card eject button pops out. When the PC card is fully inserted, fold down the PC card eject button.

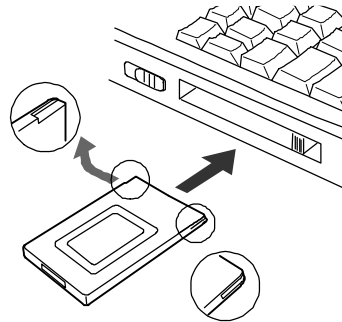



Raise the PC card eject button only when you need to push it. The eject button may get knocked off the computer if it is not pushed down. In this case, replace the button while the inserted PC card is pushed in.

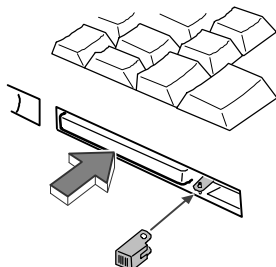

When a new card is correctly inserted, the appropriate driver is automatically installed. If the driver is not installed correctly, you will hear a warning beep. In this case, install the PC card driver by following the instructions on the screen.

Ejecting a PC Card



- *Some PC cards may become hot after long use.*
- *Be sure to use the procedure below when ejecting a PC card. Otherwise, the system may not work properly.*

1. In the *PC Card Properties* dialog box, click on the icon of the PC card you want to eject.
2. Click *Stop*.
3. When the message prompts you to eject the card, click *OK*.
4. Gently push in the PC card eject button. The PC card will be pushed out slightly.
5. Remove the card, and insert the protection card.
6. Fold down the eject button.

Connecting the Optional External CD-ROM Drive

You can connect the optional external CD-ROM drive using the PC card slot.

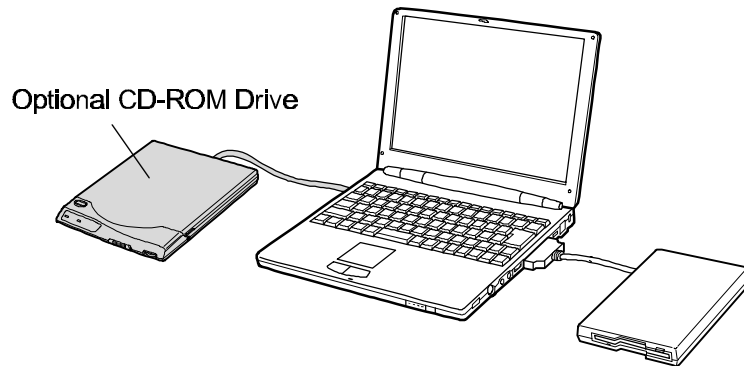

Keyboard/Mouse

You can use a full size desktop keyboard or external mouse with your computer. Two keyboard/mouse ports and one RS-232C serial port are available when the external floppy disk drive is connected.

The ways of connecting a PS/2 mouse and a serial mouse are slightly different.



Never connect or disconnect the devices to the keyboard/mouse port when the computer is powered on. This may cause the computer to operate improperly.

Using a PS/2 Mouse

You have only to connect the mouse to the keyboard/mouse port of your computer or the external floppy disk drive unit.



You cannot use the glide pad when a PS/2 mouse is connected.

Using a Serial Mouse

Connect the serial mouse to the RS-232C serial port of the external floppy disk drive unit. When starting the system, enter the Setup Utility and set the item *Serial Port:* to *Auto* or *Enabled* and *Internal Pointing Device* to *Disabled* in the *Advanced* menu.



You cannot use a mouse and the glide pad simultaneously.

Display

You can use an external monitor with your computer. To display images on both displays simultaneously, use 800 x 600 resolution.



- *Some monitors, which are not compatible with your computer, may not display correctly.*
- *In this section, you often see the expression “Display Properties dialog box.” To open the dialog box, double-click My Computer - Control Panel - Display.*

Displaying the Screen on an External Monitor

You can display the screen on an external monitor.



You cannot connect the optional external battery pack when an external monitor is connected.

1. In the *Display Properties* dialog box, select *Settings*; then select *Advanced...*
2. Select *Monitor* tab and click *Change...*
3. Click *Next*.
4. Select *Display a list of all the drivers in a specific location, so you can select the driver you want*; then, click *Next*.
5. Select *Show all hardware*.
6. Select the manufacturer and the model, and click *Next* twice.
7. Close the dialog box, following the instructions on the screen.

Switching the Display

1. In the *Display Properties* dialog box, select *Settings*; then select *Advanced ...*.
2. Select *NeoMagic* tab; then click *Display Options*.
3. Select the display and click *OK*.
4. Click *OK* twice.



- Although you can switch the display with **Fn+F5**, use the above procedure in normal use.
- While playing video or animation, you may not be able to switch the display.

Changing Resolution and Number of Colors

When shipped, your computer is set to the default resolution and color. The default resolution is 800 x 600 at 64k color. To change the resolution and the number of colors, perform the following:

1. In the *Display Properties* dialog box, select *Settings*.
2. Select the number of the colors in the *Colors*, and select the resolution in *Screen area*. Refer to the table below.
3. Click *OK* twice.

Resolutions and Colors you can choose

Resolution	Number of Colors
640 x 480	16 256 64K 16M ⁽¹⁾
800 x 600	256 64K
1024 x 768 ⁽²⁾	256

⁽¹⁾ The number of colors in this mode is made using a Dithering algorithm (on the internal LCD only).

⁽²⁾ Only 800 x 600 dots are displayed on the internal LCD. Move the cursor to show the remainder of the 1024 x 768 dots.



- You cannot switch to a display resolution and number of colors that are not available.
- In the *Color Palette*, *High Color (16 bit)* means 65,536 (64K) colors, and

True Color (24 bit) means about 16,770,000 (16M) colors.

- *If you select True Color in the Color Palette,
* The drawing speed of screen is decreased.
* The screen may seem corrupted when displaying video or animation.*
- *Note that the above resolutions are ones that you can choose when you connect a monitor with appropriate resolution.*

Audio System

You can output sound to speakers or headphones using an ordinary audio cable.

Connecting Audio Equipment

1. Turn off the computer.
2. Use the following audio cable for the connection:

To output the computer's audio signal to audio equipment:

Audio Equipment

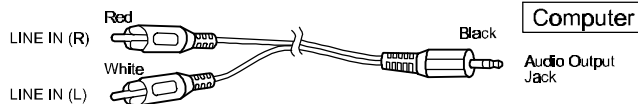

3. Turn on the computer.



- *You can adjust the volume in the operating system by clicking the speaker icon in the taskbar or with the volume control dial on the right side of your computer.*
- *When using the audio output jack, you cannot use the built-in speakers.*

Turn on/off 3D sound

1. Click the icon of the 3D sound indicator  on the taskbar.
2. Check/uncheck 3D effect.

Connecting Microphone

You can input sound using an external microphone connected to the microphone jack. When using an external microphone, you cannot use the built-in microphone.

USB Device

Your computer has a new interface called Universal Serial Bus (USB). With a USB connection, you can connect/disconnect peripherals without turning off the computer. Remove the cover of the USB port before using the port. To use a USB device, set the item *USB Port:* to *Enabled* in the *Advanced* menu of the Setup Utility. See also the manuals of peripheral devices supporting USB.

Printer

You can connect a printer to a parallel port of the external floppy disk drive unit.



Before using a printer, read the printer manual.

Setting the Setup Utility

In the *Advanced* menu of the Setup Utility, set the *LPT Port:* to *Auto* or *Enabled*. Also set the *Mode:*, referring to your printer manual.

Installing a Printer Driver

To use a printer, you need to install a printer driver.

1. From the *Start* menu, select *Settings - Printers*.
2. Double-click *Add Printer*. The *Add Printer Wizard* appears.
3. Click *Next*.
4. Confirm *Local printer* is selected and click *Next*.
5. Select the manufacturer and the printer, and click *Next*. If you cannot find the model name of your printer, you have to install the printer driver included with your printer. See your printer manual for details.
6. Select *LPT1* and click *Next*.
7. Make sure the printer name is correct, and click *Next*.
8. Decide whether to print a test page, and click *Finish*. Before printing a test page, make sure the printer is ready.

RS-232C Device

You can use RS-232C devices, such as a modem or a terminal adapter, with your computer. An RS-232C port is available on the external floppy disk drive unit. To use an RS-232C device, set the item *Serial Port:* to *Auto* or *Enabled* in the *Advanced* menu of the Setup Utility. See each manual before using the device.

CHAPTER 5

Communication Functions

This chapter explains how to use infrared communications and the built-in modem.

Infrared Communication

Using the IR (infrared) port located on the right side of your computer, you can communicate wirelessly with infrared-equipped devices such as electronic organizers, computers or printers. To establish infrared communication, follow the instructions below. See the manual or online help of each application for details.

Positioning and Preparing the Computer and the Target Device

1. Put your computer on a flat surface.
2. Place the target device so that its IR port is in line with that of your computer.
3. Adjust the distance between the IR ports to be less than 20 inches (50 cm).

Setting for Infrared Communication

1. In the *Advanced* menu of the Setup Utility, make sure the *Mode of IR Port* is *IrDA*.
2. In the *Power* menu of the Setup Utility and the *Power Management Properties* dialog box, disable power management. Refer to *Disabling Power Management* in Chapter 3.
3. In the *Infrared Monitor* dialog box in the *Control Panel*, select *Options* and enable infrared communication.



During infrared communication:

- Do not move the computer and the other IR device.
- Do not enter a suspend mode.
- Do not use a cellular phone or another IR device near the computer.
- Avoid strong light such as sunlight or fluorescent light.

- *Disable the screen saver.*

IR Mode

Your computer supports two available IR modes: IrDA (Infrared Data Association) and ASK (Amplitude Shift Keying). Each application automatically selects the appropriate IR mode.

Logical Port

For some software, you may have to change the assignment of the logical port:

1. In the *IR* dialog box, select *Ports*.
2. Change the settings, and click *OK*.
3. When the message *You have changed the infrared communication port* appears, click *OK*.

Turning Off the IR Communication

For IrDA communication, your computer is continuously emitting infrared rays to search for other IR devices. If necessary, you can temporarily disable this emission.

1. From the *Start menu*, select *Settings - Control Panel*.
2. Double-click the *IR* icon.
3. Turn off the infrared communication, and click *OK*.

Communicating With a Personal Computer

To communicate with a personal computer:

1. Right-click the file you want to send.
2. Select *Send To - Infrared Recipient*.

The file you send will be saved in *My Received Files* in the C: drive of the target personal computer.

If you cannot send the file, confirm your computer and the target computer are located correctly. Double-click *My computer - Infrared Recipient*, and check whether the name of the target computer appears in *Available infrared devices within range*. If not, relocate your computer and the target computer.

Built-in Modem (not available in some countries)

You can use the built-in modem for data transfer, fax communication and voice communication.



- *The built-in modem on your computer is designed only for regular analog telephone lines. The modem may be damaged when connected to a digital ISDN terminal or a digital PBX.*
 - *If an unusual device is attached to the line you are connecting to, the modem may not function properly. Remove the device or contact the dealer of the device.*
 - *Before connecting to a PBX, consult the PBX maintenance staff or its service company. If the electric characteristics of your PBX are different from those of a regular analog line, the modem will not function properly. If you connect the modem to a digital PBX, both the modem and the PBX may be damaged.*
-

Connecting the Modem to a Telephone Line

1. Turn off your computer.
2. Remove the cover of the modem jack on the right side of your computer and connect the end near the core of the included modem cable to the modem jack.
3. Connect the other end of the cable to the telephone line.

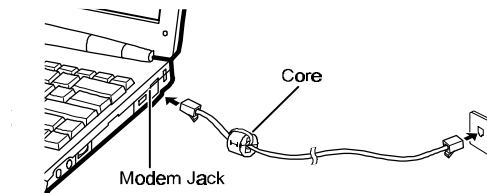

4. Turn on the computer.



Connect the modem to the telephone line directly. Do not use a distributor or allotter.

Disabling Power Management

To use communication software, you may have to disable power management. See *Disabling Power Management* in Chapter 3.

Setting Communication Information

1. In the *Modems Properties* dialog box, select *Dialing Properties*.
2. Set each item, following the instructions on the screen.

Setting Communications Software

1. Within the communications software you are using, set the COM port of the built-in modem to COM1 if you have not changed the settings in the *Advanced* menu of the Setup Utility.
2. Set parameters such as modem speed (baud rate) and line type (pulse dialing or tone dialing).



- See also the manual or online help of the software you are using.
- Do not enter a suspend mode while using communication software.
- The communication speed may vary depending on the traffic, local telecommunications infrastructure and ISP (Internet Service Provider) infrastructure.
- Before commencing with fax communication, it is recommended that you exit other application programs.
- You cannot use the built-in modem when the computer is in MS-DOS® mode.

CHAPTER 6

Security Features

This chapter describes how to protect your computer against unauthorized use, computer viruses and theft.

Passwords

Setting a password will help protect against unauthorized access to your computer. When a password is set and the computer is turned on or resumes from the suspend-to-disk mode, the system will require a password.



If you lose your password, you will be unable to access the computer or change the configuration. Make sure you select a password you will never forget, and write it down and save it in a secure place. Otherwise, you will have to contact your dealer for assistance.



If you enter a wrong password three times, the message System Disabled appears. Slide the power switch to turn off the computer, turn it on again, and enter the correct password.

Supervisor Password and User Password

Two types of passwords limit the access at different levels. To set the user password, you always have to set the supervisor password. When you set the two passwords, a person who knows only the user password has the limitations below:

When setting items in the Setup Utility

The person who does not know the supervisor password cannot set:

- Set Supervisor Password
- Password on boot
- Power Management Security

- Diskette access
- Fixed disk boot sector

When the system starts or resumes from the suspend-to-disk mode

If you have enabled *Password on boot* in the *Security* menu of the Setup Utility, the system requires a password when you turn on the computer. If you have enabled *Power Management Security* in the *Power* menu of the Setup Utility, the system requires a password when the system resumes from the suspend-to-disk mode.



The person who does not know the supervisor password cannot read/write a floppy disk when the item of Diskette access is defined as Supervisor in the Security menu of the Setup Utility.

Setting the Password

1. In the *Security* menu of the Setup Utility, select *Set Supervisor Password* or *Set User Password* and press **Enter**.
2. Type your password (up to eight characters), and press **Enter**.
3. Type the same password again, and press **Enter**.
4. When the confirmation message appears, press **Enter**.
5. Press **Esc** and select *Exit Saving Changes*.
6. Press **Enter** twice. The system restarts and asks for the password you have set.

If you use the computer personally

We recommend that you set the supervisor password. You can prevent other people from using your computer by enabling *Password on boot* in the *Security* menu of the Setup Utility.

If you share the computer with others

We recommend that a person who administers the computer set both supervisor and user passwords and let the other people know only the user password.

Deleting the Password

1. In the *Security* menu of the Setup Utility, select the password item you want to delete and press **Enter**.
2. Type your current password, and press **Enter**.
3. Without typing any characters, press **Enter**.

4. Press **Enter** again.
5. When the confirmation message appears, press **Enter**.
6. Press **Esc** and select *Exit Saving Changes*.
7. Press **Enter** twice. The system restarts.

Preventing Infection of Computer Viruses

You can protect against some viruses by limiting writing to the hard disk. To limit writing to the hard disk, set the item *Fixed disk boot sector* to *Write Protect* in the *Security* menu of the Setup Utility.



- *You cannot prevent infection of all types of viruses with the above operation.*
- *Even if a warning message appears, the system may not be infected in some cases.*

Security Slot

You can prevent theft by using a security cable and the security slot on the left or right side of your computer.

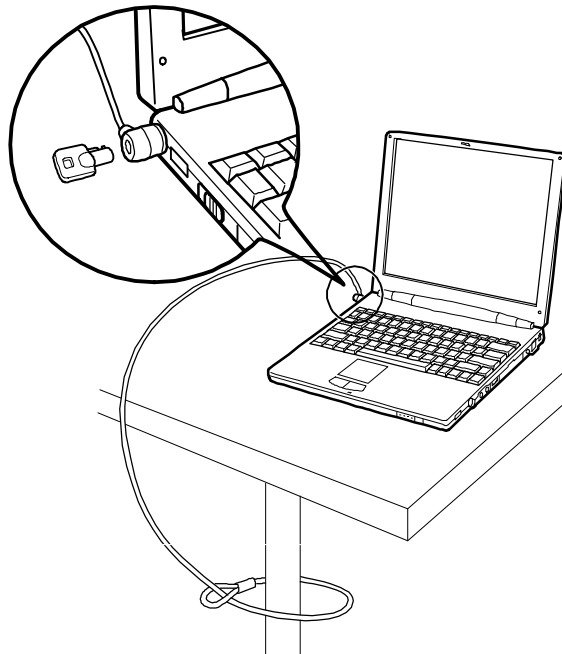

CHAPTER 7

Setup Utility

This chapter describes how to run the Setup Utility to change settings on your computer.

Running the Setup Utility

With the Setup Utility, you can customize the system configuration information, such as time and date, port assignments, passwords or power management settings. The information you have specified is saved in a special area called CMOS RAM, which the system reads every time you turn on the computer.

Contents of the Setup Utility

The Setup Utility consists of five menu pages, as follows:

- **Main:** Basic system configuration
- **Advanced:** Device interface configuration (I/O ports, sound settings)
- **Security:** Password settings
- **Power:** Power management (battery saving settings)
- **Exit:** Exit the Setup Utility or return to the default values

Entering and Exiting the Setup Utility

1. Turn on the computer.
2. When *Press <F2> to enter SETUP* appears, press **F2**.
3. Change the desired settings.
4. Press **Esc** to select the *Exit* menu.
5. Select one of the exit methods, and press **Enter**.

- When the message *Setup Confirmation* appears, press **Enter** again. The system restarts.



To turn off the computer when the Setup Utility is open, slide the power switch.

Using the Setup Utility

To navigate through the different menus, you can use the following keys:

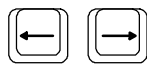

Moves the cursor from one menu to another.



Moves the cursor from one item to another in a menu.

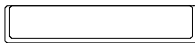

Space bar

Increases the numeric value or changes an item to the next value.



Decreases the numeric value or changes an item to the previous value.



Enters the Exit menu. When a sub-menu is open, this key closes the sub-menu.



Replaces the settings on the current menu with their default values (date and time are not changed).



Saves the settings you have changed and exits the Setup Utility.



Displays online help for the Setup Utility.

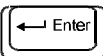

Displays sub-menu. Items with marks contain sub-menus.

Main Menu

System Time Defines the system time, using the format *hour:minute:second* (24-hour format). The **Tab** key moves the cursor, and the space bar and the "-" key change numerals.

System Date Defines the system date. The **Tab** key moves the cursor, and the space bar and the "-" key change numerals.

Diskette A Defines whether to use the floppy disk. To use it, set this item to *1.44MB, 3½"*.

Hard Disk Type Specifies the hard disk type. Set to *Auto* during normal use.

Boot Sequence Specifies the sequence in which the boot program looks for operating system files.

Internal Numlock Defines whether you can input numerals through keys with blue legends on the built-in keyboard when you connect an external keyboard and lock its numeral keys.

Memory Cache Enables or disables the memory cache function that accelerates the access speed to data previously accessed.

QuickBoot Mode Enables or disables the quick boot function. When this item is enabled, the system skips certain tests while booting.

System Memory Shows the size of conventional memory for starting MS-DOS. It always shows *640 KB*.

Extended Memory Shows the size of extended memory with 1MB or larger.

Advanced Menu

Serial Port Sets the RS-232C serial port, selecting the base I/O address. *Enabled* means that you can select the item yourself. *Auto* (default) means that the item is automatically assigned. *Disabled* means that you cannot use the port.

IR Port Sets the infrared port, selecting the mode, the I/O channel, the IRQ channel, and the DMA channel. *Enabled* means that you can select the items yourself. *Auto* means that all the items except the mode are automatically assigned. *Disabled* means that you cannot use the port. Set to *Auto* during normal use.

Mode Specifies the IR mode: IrDA or ASK. Set to *IrDA* during normal use.

LPT Port Sets the printer port, selecting the mode and the base I/O address. *Enabled* means that you can select the items yourself. *Auto* means that the base I/O address is automatically assigned. *Disabled* means that you cannot use the port.

Mode Specifies the LPT port mode: *Bi-directional*, *Output Only*, *EPP* (Enhanced Parallel Port mode) or *ECP* (Extended Capabilities Port mode).

Modem Sets the built-in modem, selecting the IRQ channel and the I/O channel. *Enabled* means that you can select the items yourself. *Auto* means that the items are automatically assigned.

Sound Sets the built-in sound controller. *MIDI* and *Joystick* do not work in your computer even if set to *Enabled* or *Auto*.

Internal Pointing Device Enables or disables the glide pad.

Resolution Expansion Defines whether the screen is expanded when the resolution is 640 x 480. *Enabled* means that the screen is expanded.

USB Port Enables or disables the USB port. Always set to *Enabled*; otherwise, some PC cards may malfunction.

Plug & Play O/S Defines whether the operating system supports the plug & play function. Set to *Yes* during normal use.

Large Disk Access Mode Selects the operating system. Set to *DOS* during normal use. If you use another operating system such as UNIX[®], select *Other*.

Security Menu



- See the previous chapter about setting passwords.
- In some password settings, you cannot select some items.

Set Supervisor Password Defines the supervisor password (up to eight characters).

Set User Password Defines the user password (up to eight characters). You cannot set the user password unless you have set the supervisor password.



If you lose your password, you will be unable to access the computer or change the configuration. Make sure to select a password you will never forget, or write it down and protect it in a secure place. Otherwise, you will have to contact your system administrator or service representative for assistance.

Password on boot Defines whether the system requires passwords during the boot process. *Enabled* means that you need to input a password to continue.

Power Management Security Defines whether the system requires a password when it resumes from the suspend-to-disk mode. *Enabled* means that you need to input a password to continue.

Diskette access Specifies who can access the floppy disk drive.

Fixed disk boot sector Defines whether the boot sector of the hard disk is write-protected. When formatting the hard disk or when reinstalling software, set it to *Normal*.

Power Menu



See Chapter 3 for information about power management and the battery.

The default Power menu options will maximize battery life under normal operating conditions.

Power Switch Function Defines the function of the power switch. If you select *On/Off*, the switch works only to turn on/off the computer. If you select *Suspend/Resume*, the system enters the mode that is specified in the item *Suspend Mode* when you slide the power switch. To resume the system, slide the power switch again.

Cover Close Specifies the mode the system enters when the screen cover is closed.

Power Management Function Enables or disables the items below: *Hard Disk Power Down after*, *Video Power Down after* and *Auto Suspend*.

Hard Disk Power Down after Defines the duration of non-access to the hard disk after which the power supply for the hard disk stops automatically.

Video Power Down after Defines the duration of non-access to the screen after which the power supply for the screen stops automatically.

Suspend Mode Defines which mode the system enters when the system is suspended.

Auto Suspend Defines whether the system enters a suspend mode when you do not operate the computer for the specified length of time.

Critical Battery Suspend Defines whether the system enters the suspend-to-disk mode when the battery power becomes low.

Auto Backlight Control Enables or disables the self-adjustment of the display backlight. When this item is enabled, for example, backlight brightness is reduced when the system operates on battery power.

Resume On Modem Ring Defines whether the system resumes from the suspend-to-RAM mode when the modem receives a call.



The built-in modem may not be available in some countries.

PCMCIA Power when Suspend RAM Defines whether the system supplies power to the PC card slot when suspended to RAM.

Battery Level Shows the amount of battery power remaining. *Battery 1* refers to the standard battery; *Battery 2* refers to the optional external battery pack.

Exit Menu

Exit Saving Changes Saves the settings you have changed and exits the Setup Utility.

Exit Discarding Changes Exits the Setup Utility without saving the settings you have changed.

Load Setup Defaults Returns the values of all items to default. To exit, select one of the above items.

Discard Changes Returns the values of all items to the values you last saved.

Save Changes Saves the settings you have changed.

CHAPTER 8

Getting Help

This chapter describes the tools Dell provides to help you when you have a problem with your computer. It also tells you when and how to call Dell for technical or customer assistance.

Help Tools

Dell provides a number of tools to assist you. These tools are described in the following sections.



Some of the following tools are not always available in all locations outside the continental U.S. Please call your local Dell representative for information on availability.

World Wide Web

The Internet is your most powerful tool for obtaining information about your computer and other Dell products. Through the Internet, you can access most of the services described in this chapter, including AutoTech, TechFax, order status, technical support and product information.

From Dell's World Wide Web home page (www.dell.com), click the **Support** icon and click **Troubleshoot Your Dell**. Enter your service tag number (or, if you have one, your Express Service Code) and click **Submit**. If you don't have your service tag or Express Service Code available, you can also select support information by system.

Everything you need to know about your system is presented on the system support page, including the following tools and information:

- Technical information — Details on every aspect of your system, including hardware specifications.

- Self-diagnostic tools — A system-specific troubleshooting application for resolving many computer-related issues by following interactive flowcharts.
- Drivers, files and utilities — The latest drivers and BIOS updates to keep your system functioning at its best.
- Component support — Technical information, documentation and troubleshooting tips for different system components.
- Online Communications Center — Tool for submitting requests for both technical and non-technical information on Dell products. Avoid telephone delays by receiving an e-mail response to your request for information if your computer is not functioning properly or if you have questions regarding your computer's hardware or operation.

Dell can be accessed electronically using the following addresses:

- World Wide Web
www.dell.com/
www.dell.com/intl/apcc/ (for Asian/Pacific countries only)
www.euro.dell.com (for Europe only)
- Anonymous file transfer protocol (FTP)
ftp.dell.com/
 Log in as **user: anonymous**, and use your e-mail address as your password.
- Electronic Support Service
support@us.dell.com
apsupport@dell.com (for Asian/Pacific countries only)
support.euro.dell.com (for Europe only)
- Electronic Quote Service
sales@dell.com
apmarketing@dell.com (for Asian/Pacific countries only)
- Electronic Information Service
info@dell.com

AutoTech Service

Dell's automated technical support service—AutoTech—provides recorded answers to the questions most frequently asked by Dell customers.

When you call AutoTech, you use your touch-tone telephone to select the subjects that correspond to your questions. You can even interrupt an AutoTech session and

continue the session later. The code number that the AutoTech service gives you allows you to continue your session where you ended it.

The AutoTech service is available 24 hours a day, seven days a week. You can also access this service through the technical support service. For the telephone number to call, refer to *Dell Contact Numbers* found later in this chapter.

TechFax Service

Dell takes full advantage of fax technology to serve you better. Twenty-four hours a day, seven days a week, you can call the Dell TechFax line toll-free for all kinds of technical information.

Using a touch-tone phone, you can select from a full directory of topics. The technical information you request is sent within minutes to the fax number you designate. For the TechFax telephone number to call, refer to *Dell Contact Numbers* found later in this chapter.

TechConnect BBS

Use your modem to access Dell's TechConnect bulletin board service (BBS) 24 hours a day, seven days a week. The service is menu-driven and fully interactive. The protocol parameters for the BBS are 1200 to 19.2K baud, 8 data bits, no parity, 1 stop bit.

Automated Order-Status System

You can call this automated service to check on the status of any Dell products that you have ordered. A recording prompts you for the information needed to locate and report on your order. For the telephone number to call, refer to *Dell Contact Numbers* found later in this chapter.

Technical Support Service

Dell's industry-leading hardware technical-support service is available 24 hours a day, seven days a week, to answer your questions about Dell hardware.

Our technical support staff pride themselves on their track record: more than 90 percent of all problems and questions are taken care of in just one toll-free call, usually in less than 10 minutes. When you call, our experts can refer to records kept on your Dell system to better understand your particular question. Our technical support staff use computer-based diagnostics to provide fast, accurate answers to questions.

To contact Dell's technical support service, first refer to the section titled *Before You Call* and then call the number for your country as listed in *Dell Contact Numbers* found later in this chapter.

Problems With Your Order

If you have a problem with your order, such as missing parts, wrong parts or incorrect billing, contact Dell Computer Corporation for customer assistance. Have your invoice or packing slip handy when you call. For the telephone number to call, refer to *Dell Contact Numbers* found later in this chapter.

Product Information

If you need information about additional products available from Dell Computer Corporation, or if you would like to place an order, visit Dell's World Wide Web site at www.dell.com/. For the telephone number to call to speak to a sales specialist, refer to *Dell Contact Numbers* found later in this chapter.

Returning Items for Warranty Repair or Credit

Prepare all items being returned, whether for repair or credit, as follows:

1. Call Dell to obtain an authorization number, and write it clearly and prominently on the outside of the box. For the telephone number to call, refer to *Dell Contact Numbers* found later in this chapter.
2. Include a copy of the invoice and a letter describing the reason for the return.

3. Include any accessories that belong with the item(s) being returned (power cables, software diskettes, guides and so on) if the return is for credit.
4. Pack the equipment to be returned in the original (or equivalent) packing materials.

You are responsible for paying shipping expenses. You are also responsible for insuring any product returned, and you assume the risk of loss during shipment to Dell Computer Corporation. Collect-on-delivery (C.O.D.) packages are not accepted.

Returns that are missing any of the preceding requirements will be refused at our receiving dock and returned to you.

Before You Call



Have your Express Service Code ready when you call. The code helps Dell's automated-support telephone system direct your call more efficiently.

If possible, turn on your system before you call Dell for technical assistance and call from a telephone at or near the computer. You may be asked to type some commands at the keyboard, relay detailed information during operations or try other troubleshooting steps possible only at the computer system itself. Make sure the system documentation is available.

Contacting Dell

When you need to contact Dell, use the telephone numbers and codes provided in the next sections. *International Dialing Codes* provides the various codes required to make long-distance and international calls. *Dell Contact Numbers* provides local telephone numbers, area codes and toll-free numbers, if applicable, for each department or service available in various countries around the world. If you are making a direct-dialed call to a location outside of your local telephone service area, determine which codes to use (if any) in *International Dialing Codes* in addition to the local numbers provided in *Dell Contact Numbers*. For example, to place an international call from Paris, France to Bracknell, England, dial the international access code for France followed by the country code for the U.K., the city code for Bracknell and then the local number.

To place a long-distance call within your own country, use area codes instead of international access codes, country codes and city codes. For example, to call Paris, France from Montpellier, France, dial the area code plus the local number.

The codes required depend on where you are calling from as well as the destination of your call; in addition, each country has a different dialing protocol. If you need assistance in determining which codes to use, contact a local or an international operator.



Toll-free numbers are for use only within the country for which they are listed. Area codes are most often used to call long distance within your own country (not internationally)—in other words, when your call originates in the same country you are calling.

International Dialing Codes

Country (City)	International Access Code	Country Code	City Code
Australia (Sydney)	0011	61	2
Austria (Vienna)	900	43	1
Belgium (Brussels)	00	32	2
Brunei	—	673	—
Canada (North York, Ontario)	011	—	Not required
Chile (Santiago)	—	56	2
China (Xiamen)	—	86	592
Czech Republic (Prague)	00	420	2
Denmark (Horsholm)	009	45	Not required
Finland (Helsinki)	990	358	9
France (Paris) (Montpellier)	00	33	(1) (4)
Germany (Langen)	00	49	6103
Hong Kong	001	852	Not required
Ireland (Bray)	16	353	1
Italy (Milan)	00	39	2
Japan (Kawasaki)	001	81	44
Korea (Seoul)	001	82	2
Luxembourg	00	352	—
Macau	—	853	Not required
Malaysia (Penang)	00	60	4

Country (City)	International Access Code	Country Code	City Code
Mexico (Colonia Granada)	95	52	5
Netherlands (Amsterdam)	00	31	20
New Zealand	00	64	—
Norway (Lysaker)	095	47	Not required
Poland (Warsaw)	011	48	22
Singapore (Singapore)	005	65	Not required
South Africa (Johannesburg)	09/091	27	11
Spain (Madrid)	07	34	1
Sweden (Upplands Vasby)	009	46	8
Switzerland (Geneva)	00	41	22
Taiwan	002	886	—
Thailand	001	66	—
U.K. (Bracknell)	010	44	1344
U.S.A. (Austin, Texas)	011	1	Not required

Dell Contact Numbers

Australia (Sydney)

Customer Technical Support toll free: 1-800-633-559
Customer Care toll free: 1-800-819-339
Corporate Sales toll free: 1-800-808-385
Transaction Sales toll free: 1-800-808-312
Fax..... toll free: 1-800-818-341

Austria (Vienna)

For technical assistance in this country after normal working hours, use one of the following numbers: (353-1) 204 4008 or (353-1) 286 5908 (English only—call is rerouted to the U.S.A.)

Technical Support 0660-8779
Customer Care 01 660 8056
Switchboard 491 04 0
Web site: support.euro.dell.com/at
E-mail: tech_support_germany@dell.com

Belgium (Brussels)

For technical assistance in this country after normal working hours, use one of the following numbers: (353-1) 204 4008 or (353-1) 286 5908 (English only—call is rerouted to the U.S.A.)

Customer Technical Support.....	02 481 92 88
Customer Care.....	02 481 91 19

Belgium (Brussels) (continued)

Home/Small Business Sales	toll free: 0800 16884
Corporate Sales.....	02 481 91 00
Fax	02 481 92 99
Switchboard.....	02 481 91 00
Web site: support.euro.dell.com/be	
E-mail: tech_be@dell.com	

Brunei

Customers in Brunei call Malaysia for sales, customer and technical assistance.

Customer Technical Support (Penang, Malaysia).....	810 4966
Customer Service (Penang, Malaysia).....	810 4949
Transaction Sales (Penang, Malaysia).....	810 4955

Canada (North York, Ontario)

Customers in Canada call the U.S.A. for access to TechConnect BBS.

Automated Order-Status System	toll free: 1-800-433-9014
AutoTech (Automated technical support).....	toll free: 1-800-247-9362
Customer Care (From outside Toronto).....	toll free: 1-800-387-5759
Customer Care (From within Toronto).....	416-758-2400
Customer Technical Support.....	toll free: 1-800-847-4096
Sales (Direct Sales—from outside Toronto)	toll free: 1-800-387-5752
Sales (Direct Sales—from within Toronto)	416-758-2200
Sales (Federal government, education and medical).....	toll free: 1-800-567-7542
Sales (Major Accounts).....	toll free: 1-800-387-5755

TechConnect BBS (Austin, Texas, U.S.A.).....512-728-8528
TechFaxtoll free: 1-800-950-1329

Chili (Santiago)

Customers in Chile call the U.S.A. for sales, customer and technical assistance.

Sales, Customer Support and
Technical Supporttoll free: 1230-020-4823

China (Xiamen)

Customer Service toll free: 800 858 2437
Sales toll free: 800 858 2222

Czech Republic (Prague)

For technical assistance in this country after normal working hours, use one of the following numbers: (353-1) 204 4008 or (353-1) 286 5908 (English only—call is rerouted to the U.S.A.)

Technical Support 02 22 83 27 27
Customer Care 02 22 83 27 11
Fax..... 02 22 83 27 14
TechFax 02 22 83 27 28
Switchboard 02 22 83 27 11
Web site: support.euro.dell.com/cz
E-mail: czech_dell@dell.com

Denmark (Horsholm)

Customers in Denmark call Sweden for fax technical support.

For technical assistance in this country after normal working hours, use one of the following numbers: (353-1) 204 4008 or (353-1) 286 5908 (English only—call is rerouted to the U.S.A.)

Technical Support 45170182
Customer Care 45170181
Switchboard 45170100
Fax Technical Support (Upplands Vasby, Sweden)..... 859005594

Fax Switchboard45170117
Web site: support.euro.dell.com/cz
E-mail: den_support@dell.com

Finland (Helsinki)

For technical assistance in this country after normal working hours, use one of the following numbers: (353-1) 204 4008 or (353-1) 286 5908 (English only—call is rerouted to the U.S.A.)

Technical Support09 253 313 60
Customer Care09 253 313 61
Fax09 253 313 99
Switchboard09 253 313 00
Web site: support.euro.dell.com/fi
E-mail: fin_support@dell.com

France (Paris/Montpellier)

For technical assistance in this country after normal working hours, use one of the following numbers: (353-1) 204 4008 or (353-1) 286 5908 (English only—call is rerouted to the U.S.A.)

Technical Support (Paris)01 47 62 68 90
Technical Support (Montpellier)04 67 06 62 86
Customer Care (Paris)01 47 62 68 92
Customer Care (Montpellier)04 67 06 61 96
TechConnect BBS (Montpellier)04 67 22 53 04
Fax (Montpellier)04 67 06 60 07
Switchboard (Paris)01 47 62 69 00
Switchboard (Montpellier)04 67 06 60 00
Web site: support.euro.dell.com/fr
E-mail: web_fr_tech@dell.com

Germany (Langen)

For technical assistance in this country after normal working hours, use one of the following numbers: (353-1) 204 4008 or (353-1) 286 5908 (English only—call is rerouted to the U.S.A.)

Customer Technical Support 06103 971-200
Customer Care 06103 971-500
TechConnect BBS 06103 971-666

Germany (Langen) (continued)

Switchboard 06103 971-0
Web site: support.euro.dell.com/de
E-mail: tech_support_germany@dell.com

Hong Kong

Customers in Hong Kong call Malaysia for customer assistance.

Technical Support toll free: 800 96 4107
Customer Service (Penang, Malaysia) 810 4949
Transaction Sales toll free: 800 96 4109
Corporate Sales toll free: 800 96 4108

Ireland (Bray)

Customers in Ireland call the U.K. for Home/Small Business customer assistance.

For technical assistance in this country after normal working hours, use one of the following numbers: (353-1) 204 4008 or (353-1) 286 5908 (English only—call is rerouted to the U.S.A.)

Customer Technical Support 1-850-543-543
Customer Care 01 204 4026
Home/Small Business Customer Care (Bracknell, U.K.).... 0870 906 0100
Sales 1-850-235-235
SalesFax..... 01 286 2020
Fax..... 01 286 6848
TechConnect BBS 01 204 4711
TechFax 01 204 4708
Switchboard 01 286 0500
Web site: support.euro.dell.com/ie
E-mail: dell_direct_support@dell.com

Italy (Milan)

For technical assistance in this country after normal working hours, use one of the following numbers: (353-1) 204 4008 or (353-1) 286 5908 (English only—call is rerouted to the U.S.A.)

Technical Support.....2 57782.690
Customer Care.....2 57782.555

Italy (Milan) (continued)

Sales.....2 57782.411
Fax.....2 57503530
Switchboard.....2 57782.1
Web site: support.euro.dell.com/it
E-mail: support_italy@dell.com

Japan (Kawasaki)

Technical Support..... toll free: 0088-22-7890
Customer Care..... 044-556-4240
Direct Sales 044-556-3344
Commercial Sales..... 044-556-3430
044-556-3440
Switchboard..... 044-556-4300

Korea (Seoul)

Customers in Korea call Malaysia for customer assistance.

Technical Support..... toll free: 080-200-3800
Transaction Sales..... toll free: 080-200-3600
Corporate Sales..... toll free: 080-200-3900
Customer Service (Penang, Malaysia).....810 4949
Fax.....394 3122
Switchboard.....287 5600

Latin America

Customers in Latin America call U.S.A. for sales, customer and technical assistance.

Customer Technical Support (Austin, Texas, U.S.A.).....	512-728-4093
Customer Service (Austin, Texas, U.S.A.).....	512-728-3619
Fax (Technical Support and Customer Service) (Austin, Texas, U.S.A.).....	512-728-3883
Sales (Austin, Texas, U.S.A.).....	512-728-4397
SalesFax (Austin, Texas, U.S.A.)	512-728-4600
	512-728-3772

Luxembourg

Customers in Luxembourg call Belgium for sales, customer and technical assistance.

For technical assistance in this country after normal working hours, use one of the following numbers: (353-1) 204 4008 or (353-1) 286 5908 (English only—call is rerouted to the U.S.A.)

Customer Technical Support (Brussels, Belgium).....	02 481 92 88
Home/Small Business Sales (Brussels, Belgium)	toll free: 080016884
Corporate Sales (Brussels, Belgium).....	02 481 91 00
Customer Care (Brussels, Belgium).....	02 481 91 19
Fax (Brussels, Belgium)	02 481 92 99
Switchboard (Brussels, Belgium).....	02 481 91 00
Web site: support.euro.dell.com/be	
E-mail: tech_be@dell.com	

Macau

Customers in Macau call Malaysia for customer assistance.

Technical Support	toll free: 0800 582
Customer Service (Penang, Malaysia)	810 4949
Transaction Sales	toll free: 0800 581

Malaysia (Penang)

Technical Support	toll free: 1 800 888 298
Customer Service	04 810 4949
Transaction Sales	toll free: 1 800 888 202

Corporate Sales..... toll free: 1 800 888 213

Mexico (Colonia Granada)

Customers in Mexico call the U.S.A. for access to the Automated Order-Status System and AutoTech.

Automated Order-Status System
(Austin, Texas, U.S.A.) 512-728-0685
AutoTech (Automated technical support)
(Austin, Texas, U.S.A.) 512-728-0686

Mexico (Colonia Granada) (continued)

Customer Technical Support..... 525-228-7870
Sales..... 525-228-7811
toll free: 91-800-900-37
toll free: 91-800-904-49
Customer Service..... 525-228-7878
Main..... 525-228-7800

Netherlands (Amsterdam)

For technical assistance in this country after normal working hours, use one of the following numbers: (353-1) 204 4008 or (353-1) 286 5908 (English only—call is rerouted to the U.S.A.)

Customer Technical Support.....020 5818838
Home/Small Business Sales toll free: 0800-0663
Home/Small Business SalesFax020 682 7171
Corporate Sales.....020 581 8818
Corporate SalesFax.....020 686 8003
Fax020 686 8003
Switchboard.....020 581 8818
Web site: support.euro.dell.com/nl

New Zealand

Technical Support0800 446 255
Customer Service0800 444 617
Sales.....0800 441 567

Fax..... 0800 441 566

Norway (Lysaker)

Customers in Norway call Sweden for fax technical support.

For technical assistance in this country after normal working hours, use one of the following numbers: (353-1) 204 4008 or (353-1) 286 5908 (English only—call is rerouted to the U.S.A.)

Technical Support 671 16882
Customer Care 671 16881

Norway (Lysaker) (continued)

Switchboard 1 16800
Fax Technical Support (Upplands Vasby, Sweden)..... 590 05 594
Fax Switchboard 671 16865
Web site: support.euro.dell.com/no
E-mail: nor_support@dell.com

Poland (Warsaw)

For technical assistance in this country after normal working hours, use one of the following numbers: (353-1) 204 4008 or (353-1) 286 5908 (English only—call is rerouted to the U.S.A.)

Technical Support 22 60 61 99
Customer Care 22 60 61 99
Sales 22 60 61 99
Fax..... 22 60 61 998
Switchboard 22 60 61 999
Web site: support.euro.dell.com/pl
E-mail: pl_support@dell.com

Singapore (Singapore)

Customers in Singapore call Malaysia for customer assistance.

Technical Support toll free: 800 6011 051
Customer Service (Penang, Malaysia) 04 810 4949

Transaction Sales..... toll free: 800 6011 054
Corporate Sales..... toll free: 800 6011 053

South Africa (Johannesburg)

Technical Support.....011 709 7710
Customer Care.....011 709 7710
Sales.....011 706 0495
Fax.....011 709 7700
Switchboard.....011 709 7700
Web site: support.euro.dell.com/za
E-mail: dell_za_support@dell.com

Southeast Asian/Pacific Countries (excluding Australia, Brunei, China, Hong Kong, Japan, Korea, Macau, Malaysia, New Zealand, Singapore, Taiwan and Thailand—refer to individual listings for these countries)

Customer Technical Support, Customer Service
and Sales (Penang, Malaysia)60 4 810-4810

Spain (Madrid)

For technical assistance in this country after normal working hours, use one of the following numbers: (353-1) 204 4008 or (353-1) 286 5908 (English only—call is rerouted to the U.S.A.)

Technical Support..... 902 100 130
Corporate Customer Care91 329 10 80
Home/Small Business Customer Care902 118 540
TechConnect BBS91 329 33 53
Corporate Sales.....902 100 185
Home/Small Business Sales902 118 541
Switchboard.....91 722 92 00
Web site: support.euro.dell.com/es
E-mail: es_support@dell.com

Sweden (Upplands Vasby)

For technical assistance in this country after normal working hours, use one of the following numbers: (353-1) 204 4008 or (353-1) 286 5908 (English only—call is rerouted to the U.S.A.)

Technical Support 08 590 05 199
Customer Care 08 590 05 169
Fax Technical Support 08 590 05 594
Sales 08 590 05 185
Web site: support.euro.dell.com/se
E-mail: swe_support@dell.com

Switzerland (Geneva)

For technical assistance in this country after normal working hours, use one of the following numbers: (353-1) 204 4008 or (353-1) 286 5908 (English only—call is rerouted to the U.S.A.)

Technical Support 0844 811 411
Customer Care 0848 802 802
Fax..... 022 799 01 90
Switchboard 022 799 01 01
Web site: support.euro.dell.com/ch
E-mail: Swisstech@dell.com

Taiwan

Customers in Taiwan call Malaysia for customer assistance.

Technical Support toll free: 0080 651 226/0800 33 557
Customer Service (Penang, Malaysia) 810 4949
Transaction Sales toll free: 0080 651 228/0800 33 556
Corporate Sales toll free: 0080 651 227/0800 33 555

Thailand

Customers in Thailand call Malaysia for customer assistance.

Technical Support toll free: 0880 060 07
Customer Service (Penang, Malaysia) 810 4949
Sales toll free: 0880 060 06

U.K. (Bracknell)

For technical assistance in this country after normal working hours, use one of the following numbers: (353-1) 204 4008 or (353-1) 286 5908 (English only—call is rerouted to the U.S.A.)

Technical Support Department	0870-908-0800
Corporate Customer Care	01344 720206
Home/Small Business Customer Care	0870-906-0010
TechConnect BBS	0870-908-0610
Sales.....	01344 720000

U.K. (Bracknell) (continued)

AutoFax.....	0870-908-0510
Web site: support.euro.dell.com/uk	
E-mail: dell_direct_support@dell.com	

U.S.A. (Austin, Texas)

Automated Order-Status System	toll free: 1-800-433-9014
AutoTech (Automated technical support).....	toll free: 1-800-247-9362

Dell Home and Small Business Group:

Customer Technical Support (Return Material Authorization Numbers)	toll free: 1-800-624-9896
Customer Service (Credit Return Authorization Numbers).....	toll free: 1-800-624-9897

National Accounts (systems purchased by established Dell national accounts [have your account number handy], medical institutions or value-added resellers [VARs]):

Customer Service and Technical Support (Return Material Authorization Numbers)	toll free: 1-800-822-8965
---	---------------------------

Public Americas International (systems purchased by governmental agencies [local, state or federal] or educational institutions):

Customer Service and Technical Support (Return Material Authorization Numbers)	toll free: 1-800-234-1490
Dell Sales.....	toll free: 1-800-289-3355

	toll free: 1-800-879-3355
Spare Parts Sales	toll free: 1-800-357-3355
DellWare®.....	toll free: 1-800-753-7201
DellWare FaxBack Service	512-728-1681
Fee-Based Technical Support.....	toll free: 1-800-433-9005
Sales (Catalogs).....	toll free: 1-800-426-5150
Fax	toll free: 1-800-727-8320
TechFax.....	toll free: 1-800-950-1329
TechConnect BBS.....	512-728-8528
Switchboard.....	512-338-4400



APPENDIX A

Maintenance and Specifications

Maintenance

This section provides you with information on how to maintain the computer in excellent working condition.

Cleaning the Computer

Cabinet

Apply a small amount of mild cleaning solution to a dry, lint-free cloth and wipe the cabinet with the cloth.



- *Do not use alcohol, benzene, thinner or other strong chemical agents that may damage the cabinet.*
 - *Never clean the computer while it is powered on.*
-

Screen

The surface of the screen may become smeared and accumulate dust during use. Avoid touching the screen with your fingers when using the system. Gently wipe the surface of the screen with a soft cloth that has been dipped in a mild detergent solution and squeezed dry.

IR Port

Dust on the IR port will interfere with data transfer. Wipe the port clean with a soft, dry cloth.

Glide Pad

Wipe the glide pad with a soft, dry cloth.

Traveling With the Computer

This computer is designed for portability. For safety and convenience when traveling, please follow these guidelines:

- Before traveling, back up your data on floppy disks or other external media.
- Take an extra copy of your backup data.
- Do not travel with an external floppy disk drive unit or optional CD-ROM drive connected.
- Do not travel with the computer powered on. This may result in loss of data and/or damage to the hard disk drive.
- Disconnect the AC adapter from the computer.
- Fully charge the standard battery pack and take the AC adapter and the AC power cord.
- Avoid sudden shocks or extreme vibration.

Specifications

Parts		Specifications
CPU		MMX™ technology Pentium® Processor using Intel's Mobile Module (frequency differs by configuration)
Secondary cache		Synchronous, PipeLine Burst SRAM (256KB)
ROM		Including system BIOS and VGA BIOS
RAM	System	EDO 64MB
	Video	EDO 2MB
Display	Panel	Active Matrix (TFT) color LCD
	Video controller	NeoMagic (NM2160)
Keyboard		IBM compatible keyboard
Pointing device		Glide pad (touch-sensitive control pad with 2 buttons)
Drive	Hard disk	IDE interface
	External floppy disk	3.5", 1.44MB/720KB
PC card slot		Type II × 1 (PCMCIA 2.1 compliant) CardBus compliant
Audio system		Microphone, monaural speaker, sound system compliant with Sound Blaster Pro
I/O ports	Audio	Audio output jack, external microphone jack
	Video	External monitor port
	Others	Keyboard/mouse port, USB port, modem jack
	Others (on external floppy disk drive)	Parallel port, RS-232C serial port, keyboard/mouse port
Infrared		IR port (IrDA:115Kbps/1Mbps/4Mbps, ASK:9600bps)
Modem (may not be available in some countries)		Data: 56Kbps(receive), 33.6Kbps(send), Fax: 14.4Kbps, with voice function
Power	AC adapter	100-240V, 50-60 Hz
	Battery	Rechargeable lithium ion battery
	Battery life	Approximately 2 hours (standard battery only) Approximately 8.5 hours (when external battery connected) *battery life may vary depending on usage
	Battery charging time (standard and optional external battery pack)	Turned off/suspended to disk: about 5.5 hours Turned on: about 7.5 hours *charging time may vary depending on usage
Dimensions	Computer	10.2" wide x 8.3" deep x 0.85" (min.)/1.11" (max.) high (259mm x 212mm x 21.2mm (min.)/28.3mm (max.))
	Floppy disk drive unit	4.65" wide x 6.81" deep x 0.94" high (118mm x 173mm x 24mm)
Operating environment	Temperature	50F to 95F (10C to 35C)
	Humidity	20% to 80% (non-condensation)

Options

- AC Adapter
- External battery pack
- Carrying case
- PC Cards
- External CD-ROM drive

APPENDIX B

Troubleshooting

This chapter describes how to troubleshoot computer problems.

Common Problems

Problems with your computer can be caused by something as minor as an unplugged power cord or as major as a damaged hard disk drive. The information in this troubleshooting section is designed to help you find and solve minor problems. If you still have a problem after trying all the suggested remedies in this chapter, contact your service representative.

The problems that you might encounter can be divided into two basic categories: hardware and software. Hardware problems can be further divided into being of an electrical or a mechanical nature. You will know you have a hardware problem if, for example, the screen is blank, or the computer cannot recognize the disk drives.

Software problems can occur at several levels. Both your operating system and your software application programs are capable of generating errors and error messages. If you encounter a software error, try to determine if the error message is from your operating system or from an application program, and refer to the appropriate manual for possible remedies.

You can also refer to the operating system manual or Windows Help program to solve the problem. To access the Help program, select *Help* from the *Start* menu. It also gives you Troubleshooting tips and an Index.

Successful troubleshooting is the result of careful observation, deductive reasoning, and an organized approach to solving the problem. If you encounter a problem, begin by performing a careful visual inspection. Check the exterior of the computer first. If no lights are displayed, check the battery charge or power outlet, the plug and power cord, and any power switches that may affect your computer. If the

computer has been connected to any peripheral devices, look for loose or disconnected cables. You may also need to check the fuses and breakers in your electric box. A few common problems and suggested solutions are presented in the examples which follow.

Trouble When Starting

Question: Why doesn't the power switch function?

- Make sure the AC power cable is correctly connected to a live wall outlet.
- If the computer is operating with batteries, batteries may be discharged. Connect the computer to a wall outlet.

Question: Why doesn't Windows start?

- Check whether the external floppy disk drive unit contains a non-system disk. Remove the floppy disk from the drive, and press any key.
- If you are attempting to boot from the external floppy disk drive, check to make sure the disk is fully inserted and seated into the drive.
- If you attempt to boot from the external floppy disk drive, check whether the *Diskette Drive* is the first device in *Boot Sequence* in the *Main* menu of the Setup Utility.

Question: Why do I get a non-system disk or disk error message?

- You may have inserted a non-bootable disk in the external floppy disk drive unit (either a defective disk or one without an installed operating system). Remove the disk.
- If this message is issued when you attempt to boot from your hard disk drive, insert a bootable disk into the external floppy disk drive unit and check the status of your hard disk drive.
- Check whether the items *Diskette A:* and *Hard Disk Type:* are correctly set in the *Main* menu of the Setup Utility.

Question: Why do I get the message *Operating system not found*?

- If you get this message when starting from the hard disk, insert the boot up disk into the external floppy disk drive unit; then check the condition of the hard disk.
- Enter the Setup Utility and check the status of the hard disk. Check the size of the hard disk and make sure the item *Hard Disk Type* of *Main* menu is set to *Auto*.

Trouble With Display

See also the *Display* section in Chapter 4.

Question: Why is the screen blank?

- Press any key to see if any power management feature has turned off the screen to save power.
- See the power indicator to check whether the computer is powered.
- If you are using a standard battery pack, make sure it has a charge remaining. If you are using an external battery pack, make sure it is connected correctly and has a charge remaining.
- Make sure the LCD screen is selected as the display by pressing **Fn+F5**.
- Check the brightness controls for your display by pressing **Fn+F7**.
- Check whether the back light is on by pressing **Fn+F11**.
- If you still have the problem after trying the above, slide and hold the power switch for more than five seconds to turn off the system. Five seconds later, turn the computer on.
- If you cannot power off the system using the above procedure, slide the reset switch on the bottom of your computer and turn off the system. Wait five seconds and turn the computer back on.

Question: Why does the external monitor display nothing?

- Confirm the monitor is turned on.
- Confirm the monitor is connected correctly.
- Make sure an external monitor is selected as the display by pressing **Fn+F5**.

Question: Why is the image on an external monitor display distorted?

- Confirm the monitor is connected correctly.
- Make sure the CRT is not near any electric devices having strong magnetic fields such as a TV set or radio.
- Do not share an outlet with a TV set or radio.
- Make sure the value of the *Screen area* in the *Display Properties* is lower than the resolution of the CRT monitor.

Trouble With Hard Disk

Question: Why can't I read or write data to/from the hard disk?

- Confirm the drive and file names are correct.
- Confirm the hard disk has sufficient free space.
- The hard disk in your computer is formatted with FAT32. You cannot read or write data formatted in other operating systems, which are not FAT32 compatible. Applications that are not compliant with FAT32 may not work properly.
- If you cannot re-install the operating system correctly, check whether the item *Fixed disk boot sector*: in the *Security* menu of the Setup Utility is *Normal*.

Trouble With Floppy Disks

Question: Why can't I use a floppy disk?

- Confirm the external floppy disk drive unit is correctly connected.
- Confirm the floppy disk is inserted correctly.
- The floppy disk may not be formatted or could be corrupted.
- If you cannot write to a floppy disk, the disk may be write-protected. Eject the disk and ensure that the write-protect tab covers the detection hole.
- If you cannot write to a floppy disk, the disk may be full. Use another disk.
- Confirm the item *Diskette A*: is *1.44MB, 3 ½* in the *Main* menu of the Setup Utility.
- Check whether the supervisor has set a password prohibiting access to the floppy disk drive in the *Security* menu of the Setup Utility.

Trouble With Keyboard/Glide Pad

Question: Why doesn't the keyboard or the glide pad function?

- Perform a software reset by pressing **Ctrl+Alt+Delete**.
- If you cannot perform a software reset, slide and hold the power switch for more than five seconds to turn off the system. Five seconds later, turn the computer on.
- If you still cannot turn off the system with the power switch, slide the reset switch on the bottom of your computer to turn off the system. Five seconds later, turn on the computer by sliding the power switch.

Question: Why doesn't the glide pad function correctly?

- Confirm the surface of the glide pad is completely dry and free from dirt and grease.
- Confirm the item *Internal Pointing Device* in the *Advanced* menu of the Setup Utility is enabled.

Trouble With Peripherals

Question: Why don't expansion or peripheral devices function?

- Confirm they are correctly connected to your computer or the external floppy disk drive.
- Confirm the external floppy disk drive is connected correctly to the computer if peripheral devices are connected to the external floppy disk drive.
- Confirm drivers necessary for operating ports on the devices are installed.
- There may not be a free IRQ (Interrupt). Free up an IRQ from a built-in device.

Question: Why can't I print?

- Make sure the printer is turned on.
- Check whether the external floppy disk drive and the printer are connected correctly.
- Check whether the printer has enough paper.
- Check whether the printer driver is installed.
- Make sure *LPT Port* in the *Advanced* menu of the Setup Utility is set correctly.

- From the *Start* menu, select *Settings - Printers* to confirm your printer is installed here. If not, click *Add Printer* to install your printer.
- See also the Windows Help.

Question: Why doesn't the device connected to the RS-232C serial port function?

- Confirm the device is correctly connected to the external floppy disk drive with an appropriate cable.
- Confirm the external floppy disk drive unit is connected correctly.
- Confirm the application program is compliant with the RS-232C standard interface.
- Confirm the COM1 port is not disabled using the following procedure.
 1. In the *System Properties* dialog box, select *Device Manager*.
 2. Double-click *Ports (COM&LPT)*; then double-click *Communications Port (COM1)*.
 3. Make sure the item *Disable in this hardware profile* is unchecked.
- Confirm the COM 1 port is not used by another applications.
- Confirm the item *Serial Port* is set appropriately in the *Advanced* menu of the Setup Utility.

Trouble With Communication

Question: Why can't I communicate through the built-in IR port?

- Confirm the IR port of your computer is lined up with the IR port of the other device. These ports should be no more than 20 inches (50 cm) apart without any obstacles.
- Confirm that IR communication is not turned off in the *IR* dialog box.
- Confirm the item *Mode of IR Port* is set to *IrDA* in the *Advanced* menu of the Setup Utility.
- Turn off power management both in the Windows and the Setup Utility.
- Do not use the IR port under intense fluorescent light or near cellular phones.

Question: Why can't I communicate through the built-in modem?

(The built-in modem may not be available in some countries)

- Confirm the item *Modem* is set to *Enabled* or *Auto* in the *Advanced* menu of the Setup Utility.
- Confirm the telephone line is properly connected to the modem jack.
- Confirm the dial settings of the communication software are matched with the telephone line (Example: To access an outside line, first dial "7" for local, "1" for long distance).
- Confirm the network configuration is appropriate.
- Confirm the user name or password is correct.
- Confirm the COM port in the communication software is set appropriately.
- Turn off the power management both in the Windows and the Setup Utility.

Other Troubles

Question: Why is the date and/or time incorrect?

- Correct the date and time using the *Date/Time* icon in the Windows Control Panel or the *Main* menu of the Setup Utility.

Question: Why can't I produce sound?

- Check the volume control on the right side of your computer.
- Click the speaker symbol on the taskbar and check the Windows volume control.

Question: Why can't I use a hardware device?

- Make sure the hardware device is not crossed out with an X mark using the following procedure.
 1. In the *System Properties* dialog box, select *Device Manager*.
 2. Select the device you cannot use.
 3. Click *Properties*, and uncheck *Disable in this hardware profile*.

APPENDIX C

Warranty, Return Policy, and Year 2000 Statement of Compliance

Limited One-Year Warranty (U.S. and Canada Only)

Dell Computer Corporation ("Dell") manufactures its hardware products from parts and components that are new or equivalent to new in accordance with industry-standard practices. Dell warrants that the hardware products it manufactures will be free from defects in materials and workmanship. The warranty term is one year beginning on the date of invoice, as described in the following text.

Damage due to shipping the products to you is covered under this warranty. Otherwise, this warranty does not cover damage due to external causes, including accident, abuse, misuse, problems with electrical power, servicing not authorized by Dell, usage not in accordance with product instructions, failure to perform required preventive maintenance, and problems caused by use of parts and components not supplied by Dell.

This warranty does not cover any items that are in one or more of the following categories: software; external devices (except as specifically noted); accessories or parts added to a Dell system after the system is shipped from Dell; accessories or parts added to a Dell system through Dell's system integration department; accessories or parts that are not installed in the Dell factory; or DellWare products. Monitors, keyboards, and mice that are Dell-branded or that are included on Dell's standard price list are covered under this warranty; all other monitors, keyboards, and mice (including those sold through the DellWare program) are not covered.

Dell will repair or replace products covered under this limited warranty that are returned to Dell's facility. To request warranty service, you must call Dell's

Customer Technical Support within the warranty period. Refer to the chapter titled “Getting Help” in this manual to find the appropriate telephone number for obtaining customer assistance. If warranty service is required, Dell will issue a Return Material Authorization Number. You must ship the products back to Dell in their original or equivalent packaging, prepay shipping charges, and insure the shipment or accept the risk of loss or damage during shipment. Dell will ship the repaired or replacement products to you freight prepaid if you use an address in the continental U.S. or Canada, where applicable. Shipments to other locations will be made freight collect.



Before you ship the product(s) to Dell, back up the data on the hard-disk drive(s) and any other storage device(s) in the product(s). Remove any removable media, such as diskettes, CDs, or PC Cards. Dell does not accept liability for lost data or software.

Dell owns all parts removed from repaired products. Dell uses new and reconditioned parts made by various manufacturers in performing warranty repairs and building replacement products. If Dell repairs or replaces a product, its warranty term is not extended.

General Provisions

THIS WARRANTY GIVES YOU SPECIFIC LEGAL RIGHTS, AND YOU ALSO MAY HAVE RIGHTS WHICH VARY FROM STATE TO STATE (OR JURISDICTION TO JURISDICTION). DELL’S RESPONSIBILITY FOR MALFUNCTIONS AND DEFECTS IN HARDWARE IS LIMITED TO REPAIR AND REPLACEMENT AS SET FORTH IN THIS WARRANTY STATEMENT. ALL EXPRESS AND IMPLIED WARRANTIES FOR THE PRODUCT, INCLUDING BUT NOT LIMITED TO ANY IMPLIED WARRANTIES OF AND CONDITIONS OF MERCHANTABILITY AND FITNESS FOR A PARTICULAR PURPOSE, ARE LIMITED IN DURATION TO THE WARRANTY PERIOD SET FORTH ABOVE AND NO WARRANTIES, WHETHER EXPRESS OR IMPLIED, WILL APPLY AFTER SUCH PERIOD. SOME STATES (OR JURISDICTIONS) DO NOT ALLOW LIMITATIONS ON HOW LONG AN IMPLIED WARRANTY LASTS, SO THE ABOVE LIMITATION MAY NOT APPLY TO YOU.

DELL DOES NOT ACCEPT LIABILITY BEYOND THE REMEDIES SET FORTH IN THIS WARRANTY STATEMENT. THESE WARRANTIES GIVE YOU SPECIFIC LEGAL RIGHTS AND YOU ALSO MAY HAVE OTHER RIGHTS WHICH VARY FROM STATE TO STATE.

DELL DOES NOT ACCEPT LIABILITY BEYOND THE REMEDIES SET FORTH IN THIS WARRANTY STATEMENT OR LIABILITY FOR

INCIDENTAL OR CONSEQUENTIAL DAMAGES, INCLUDING WITHOUT LIMITATION ANY LIABILITY FOR PRODUCTS NOT BEING AVAILABLE FOR USE OR FOR LOST DATA OR SOFTWARE. SOME STATES (OR JURISDICTIONS) DO NOT ALLOW THE EXCLUSION OR LIMITATION OF INCIDENTAL OR CONSEQUENTIAL DAMAGES, SO THE ABOVE EXCLUSION OR LIMITATION MAY NOT APPLY TO YOU.

These provisions apply to Dell's limited one-year warranty only. For provisions of any service contract covering your system, refer to your invoice or the separate service contract that you will receive.

If Dell elects to exchange a system or component, the exchange will be made in accordance with Dell's Exchange Policy in effect on the date of the exchange. In any instance in which Dell issues a Return Materials Authorization Number, Dell must receive the product(s) for repair prior to the expiration of the warranty period in order for the repair(s) to be covered by the warranty.



If you chose one of the available warranty and service options in place of the standard limited one-year warranty described in the preceding text, the option you chose will be listed on your invoice.

“Total Satisfaction” Return Policy (U.S. and Canada Only)

If you are an end-user customer who bought new products directly from a Dell company, you may return them to Dell within 30 days of the date of invoice for a refund or credit of the product purchase price. If you are an end-user customer who bought reconditioned or refurbished products from a Dell company, you may return them to Dell within 14 days of the date of invoice for a refund or credit of the product purchase price. In either case, the refund or credit will not include any shipping and handling charges shown on your invoice. If you are an organization that bought the products under a written agreement with Dell, the agreement may contain different terms for the return of products than specified by this policy.

To return products, you must call Dell Customer Service to receive a Credit Return Authorization Number. Refer to the chapter titled “Getting Help” in this manual to find the appropriate telephone number for obtaining customer assistance. To expedite the processing of your refund or credit, Dell expects you to return the products to Dell in their original packaging within five days of the date that Dell

issues the Credit Return Authorization Number. You must also prepay shipping charges and insure the shipment or accept the risk of loss or damage during shipment. You may return software for refund or credit only if the sealed package containing the diskette(s) or CD(s) is unopened. Returned products must be in as-new condition, and all of the manuals, diskette(s), CD(s), power cables, and other items included with a product must be returned with it. For customers who want to return, for refund or credit only, either applications software or an operating system that has been installed by Dell, the whole system must be returned, along with any media and documentation that may have been included in the original shipment.

This "Total Satisfaction" Return Policy does not apply to DellWare products, which may be returned under DellWare's then-current return policy. In addition, reconditioned parts purchased through Dell Spare Parts Sales in Canada are nonreturnable.

Year 2000 Statement of Compliance for Dell-Branded Hardware Products

Dell-branded hardware products shipped on or after January 1, 1997, are eligible to carry the "NSTL Hardware Tested Year 2000 Compliant" logo by virtue of formal testing with, and successful completion of, the National Software Testing Laboratories (NSTL) YMARK2000 test.* Dell will treat a failure to pass the YMARK2000 test as a covered event under Dell's warranty for the product, subject to the normal warranty limitations.** For a complete copy of Dell's warranty, see the product's documentation. Dell-branded hardware products will also recognize the year 2000 as a leap year.

*The YMARK2000 standard tests the ability of system hardware and firmware to support the transition to the year 2000 (and to recognize leap years, when appropriate, for years 2000 through 2009 inclusive) and not that of options, operating systems, or applications software. Dell-branded hardware products that pass the YMARK2000 test conform to BSI-DISC PD 2000-1.

** Except for this clarification of Dell's warranty for NSTL logo hardware, all other warranties, conditions and remedies, express or implied, relating to year 2000 readiness or compliance are disclaimed. To make a claim under this warranty for NSTL logo hardware, customers must contact Dell prior to January 1, 2001. Despite a system's ability to pass the YMARK2000 test, actual rollover results in specific operating environments may vary depending on other factors including, but not limited to, other hardware, operating systems, and applications software.

Previous Products

For Dell-branded hardware products shipped prior to January 1, 1997, that have an upgradable basic input/output system (BIOS), Dell makes available a BIOS upgrade. Although these products may not have been tested under the YMARK2000 test, Dell believes that the hardware would pass the YMARK2000 test, provided the appropriate BIOS upgrade is properly loaded.

For Dell-branded hardware products that do not have an upgradable BIOS, Dell has made available, as a convenience to customers, the Dell Program Patch, a software utility designed to assist customers in managing the year 2000 rollover.

Software

Dell specifically excludes all non-Dell-developed software from this compliance statement. All software run on Dell-branded hardware products should be independently verified by customers to be year 2000-compliant.

Additional Information

For additional information on year 2000 compliance of Dell-branded hardware products, refer to Dell's Year 2000 Web site at **www.dell.com/year2000** or contact a Dell customer service representative in your area.

Index

3

3D sound, 4-8

A

AC adapter, 2-2

assistance

 contacting Dell, 8-5

 warranty repair or credit, 8-4

audio, 4-8

AutoTech service, 8-2

B

backing up data, 2-9

battery pack

 changing, 3-4

 charging, 3-3

 charging the battery, 3-7

 checking the battery level, 3-2, 3-6

 initializing, 3-3, 3-7

 low battery indication, 3-3

 optional external battery pack, 3-5

 standard battery, 3-1

C

computer viruses, 6-3

connecting

 keyboard/mouse, 4-5

 peripheral device, 4-1

 printer, 4-9

D

display

 external monitor, 4-6

 resolution and number of colors, 4-7

 switching, 4-7

E

external battery pack

 connecting, 3-5

 removing, 3-6

external floppy disk drive unit

 connecting, 2-6

 removing, 2-7

F

floppy disk

 handling, 2-7

 inserting and removing, 2-8

floppy disk drive unit

 connecting, 2-6

 removing, 2-7

G

glide pad, 2-3

 changing the configuration, 2-5

 using, 2-4

H

help tools

 AutoTech service, 8-2

 Internet, 8-1

 TechConnect BBS, 8-3

 TechFax service, 8-3

I

indicator

 battery power, 2-1

 power, 2-1

infrared communication, 5-1

 positioning and preparing, 5-1

 setting, 5-1

Internet help tools, 8-1

K

keyboard, 2-5
connecting, 4-5
system function keys, 2-5

L

logical port, 5-2

M

microphone, 4-8
modem, 5-3
mouse, 4-5

P

password
deleting, 6-2
setting, 6-2
PC card
ejecting, 4-4
inserting, 4-3
power indicators, 2-1
power management
disabling, 3-10
stopping power supply to the display, 3-8
stopping power supply to the hard disk, 3-8
power source, 2-1
power switch, 2-2
printer, 4-9
problems
with your order, 8-4
product information, 8-4
properties dialog box, 1-3

R

regulatory information, v
reset switch, 2-3
resetting, 2-2
return policy, C-4
returns, 8-4
RS-232C device, 4-10

S

safety precautions, xii
security slot, 6-4
setting up Windows 98, 1-3
Setup Utility
Advanced menu, 7-5
entering and exiting, 7-1
Exit menu, 7-8
Main menu, 7-4
Power menu, 7-7
running, 7-1
Security menu, 7-6
using, 7-2
shutting down the system, 1-4
supervisor password, 6-1
suspend modes, 3-8
entering, 3-8
Suspend-to-disk mode, 3-8
Suspend-to-RAM mode, 3-8

T

TechConnect BBS, 8-3
TechFax service, 8-3
technical assistance
contacting Dell, 8-5
warranty repair or credit, 8-4
troubleshooting
Internet tools, 8-1
turning power on, 1-1

U

USB device, 4-9
user password, 6-1

W

warm boot, 2-2
warranty, C-1
warranty repair or credit, 8-4
Windows logo keys, 2-5
World Wide Web help tools, 8-1

Y

year 2000 compliance, C-5