



POWERWARE[®]

9350

*Series 685 and 1085
Auxiliary Battery
Cabinets*

Installation Manual

164201408 Rev. P00

IMPORTANT SAFETY INSTRUCTIONS

Instructions Importantes Concernant La Sécurité

SAVE THESE INSTRUCTIONS

Conserver Ces Instructions

This manual contains important instructions for your battery system. You should follow these instructions during the installation and maintenance of the battery cabinets.

Cette notice contient des instructions importantes concernant la sécurité.

The installation of battery cabinets should be performed or supervised by personnel knowledgeable of batteries and their associated precautions. Keep unauthorized personnel away from battery cabinets.

Observe these precautions when working on or around battery cabinets:

- Remove watches, rings, or other metal objects.
- Use tools with insulated handles.
- Wear rubber gloves and boots.
- Do not lay tools or metal parts on top of batteries or battery cabinets.
- Disconnect the charging source prior to connecting or disconnecting terminals.
- The battery cabinet frame is not referenced to the DC circuit.
- When replacing batteries, use the same number and type of sealed, lead-acid batteries.
- Refer to local codes for proper disposal requirements for used batteries.

CAUTION:
Do not dispose of battery or batteries in a fire.
The battery may explode.

CAUTION:
Do not open or mutilate the battery or batteries.
Released electrolyte is harmful to the skin and eyes, and may be toxic.

CAUTION:
A battery can cause electrical shock, burn from high short-circuit current, or fire.
Observe proper precautions.

ATTENTION:

Une batterie peut présenter un risque de choc électrique, de brûlure, ou d'incendie. Suivre les précautions qui s'imposent.

- Pour le remplacement, utiliser le même nombre et modèle des batteries.
- L'élimination des batteries est réglementée. Consulter les codes locaux à cet effet.

General Notes About Installing Battery Cabinets

Each battery cabinet is packed and crated separately for shipping. You should unpack and inspect each cabinet, roll it to its final position, and join it to the UPS or other cabinets (refer to Chapter 3 or Chapter 4) before installing wiring.

These general installation notes apply to *either* the Series 685 Battery Cabinet or the Series 1085 Battery Cabinet:

- Do not tilt battery cabinets more than $\pm 10^\circ$ during installation.
- The recommended minimum clearance over each battery cabinet is 305 mm (12 in.).
- The conduit landing plates are removable to add conduit landing holes as required. The conduit landing plates should be removed when holes are added to keep metal particles from falling inside the battery cabinet. Plate material is 16 gauge steel (1.5 mm, 0.06 in. thick).
- Low voltage signal wiring must be installed in a separate conduit from the power wiring.
- Each battery cabinet can be installed as a stand-alone unit or as part of a redundant joined system.
- The instantaneous trip circuit breakers for the Series 685 and Series 1085 Battery Cabinets must remain set at minimum (full counterclockwise).

UPS Systems Using Series 685 and Series 1085 Battery Cabinets

- Powerware 9350 (30 kVA–80 kVA)
- Powerware 9350 (100 kVA–160 kVA)

Conventions Used in This Manual

The text in this manual uses these conventions:

- **Bold type** highlights important concepts in discussions and key terms in procedures.
- *Italic type* highlights notes and new terms where they are defined.
- Rectangular boxes containing bold type are warnings or cautions that pertain to the battery system or its electrical connections.

In this manual, the term *UPS* refers only to the UPS cabinet and its internal elements. The term *UPS system* refers to your entire power protection system—the UPS cabinet plus battery cabinets that you have installed.

Read through each installation procedure before you begin it. Perform only those procedures that apply to the battery system you are installing.

NOTE: *The term “Separate” refers to battery cabinets that are not physically attached to the UPS, are wired with external contractor supplied wiring, and use a single overcurrent protection and disconnect device located near the batteries.*

The term “Integral” refers to battery cabinets that are physically attached to the UPS and the wiring between them is internal. The power wiring is supplied with the system, and they use the UPS battery switch as the battery isolation device.

Table of Contents

1 Introduction	1
Typical Battery Cabinets	1
Identification of Your Battery System	2
For More Information	4
Getting Help	4
2 Unpacking Your Battery Cabinet	5
Preparing Your Site	5
Environmental Considerations	5
Preparing for Wiring the Battery Cabinet	5
Inspecting and Unpacking Each Cabinet	6
Unloading the Battery Cabinet from the Pallet	7
Creating an Installation Plan	9
NOTES:	10
3 Connecting to Powerware 9350 30 thru 160	11
The Powerware 9350 UPS with Integral Battery Cabinets	11
Powerware 9350 UPS with Separately Located Battery Cabinets	20
Separate Installation of Series 685 Battery Cabinets	21
Separate Installation of Series 1085 Battery Cabinets	23
Completing the Installation Checklist	27
Installation Checklist for Powerware 9350 30 through 160	27
4 Connecting to Powerware 9350–80 and 160	29
The Powerware 9350–80 or 160 with Separate Battery Cabinets	30
Completing the Installation Checklist	31
Installation Checklist for Powerware 9350–80 or 160	32
5 Installing a Remote Battery Disconnect	33
Appendix A — Customer Information	A–1

dd
dd

Figure 1.	Typical Battery Cabinets	1
Figure 2.	UPS with Lineup and Match Battery Cabinet	2
Figure 3.	UPS with Separate Battery Cabinets (Attached to Each Other)	3
Figure 4.	Cabinet as Shipped, with Outer Packaging and Pallet	6
Figure 5.	Removing Front and Rear Supports	8
Figure 6.	UPS with Integral Battery Cabinet	11
Figure 7.	Placement of Attaching Brackets, UPS to Battery Cabinet	13
Figure 8.	Attaching UPS Base to Series 1085 Base	14
Figure 9.	Attaching UPS Base to Series 685 Base	15
Figure 10.	Series 685 Battery Cabinet Wiring Detail	17
Figure 11.	Series 685 and 1085 Battery Cabinet Hanger Brackets	18
Figure 12.	Series 1085 Battery Cabinet Wiring Detail	19
Figure 13.	UPS with Separately Located Battery Cabinets	20
Figure 14.	Placement of Joining Brackets (Two or More Series 685 Battery Cabinets)	21
Figure 15.	Connecting Two Series 685 Bases	22
Figure 16.	Placement of Joining Brackets (Two or More Series 1085 Battery Cabinets)	23
Figure 17.	Connecting Two Series 1085 Bases	24
Figure 18.	Battery Connections for a Powerware 9350–80	29
Figure 19.	Battery Connections for a Powerware 9350–160	30
Figure 20.	Remote Battery Disconnect Enclosure	33
Figure 21.	Knockout Pattern for Remote Battery Disconnect	35

1

Introduction

This manual describes how to install the Powerware 9350 Series 685 or Series 1085 Battery Cabinet (see Figure 1). It contains instructions for unpacking and inspecting the battery cabinet, locating the battery cabinet with respect to the UPS, and electrically connecting the battery cabinet to the UPS. The information you will use depends on the type of UPS and series of battery cabinet that you purchased.

Typical Battery Cabinets

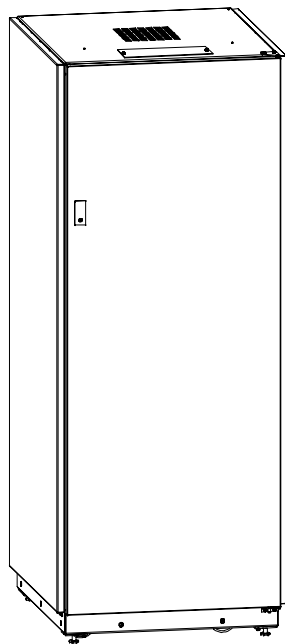

Series 685 Battery Cabinet

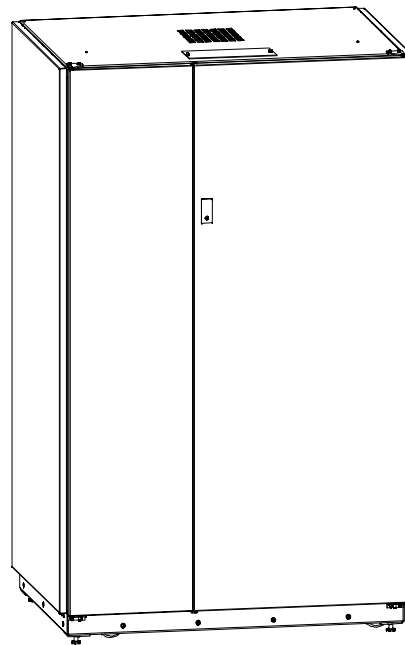

Series 1085 Battery Cabinet

Figure 1. Typical Battery Cabinets

Two basic battery cabinet configurations are possible:

- The UPS and one or more battery cabinets in an integral configuration (see Figure 2).
- The UPS and one or more battery cabinets separately installed (see Figure 3).

Identification of Your Battery System

Refer only to the parts of this manual that apply specifically to your system configuration. See Figures 2 and 3 to determine where to find your system installation instructions in this manual.

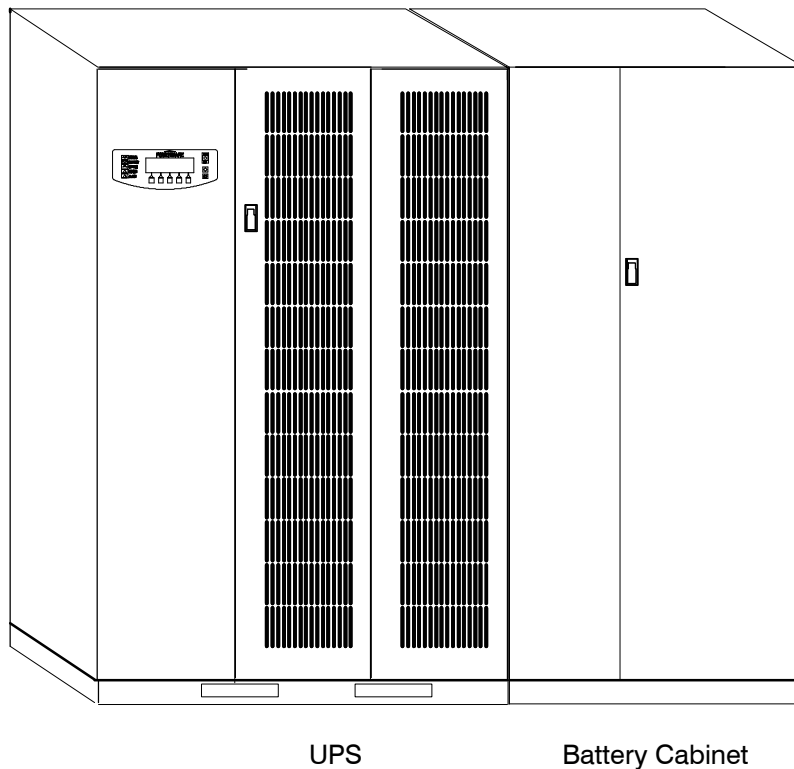

Figure 2. UPS with Lineup and Match Battery Cabinet

For installation instructions, refer to “The Powerware 9350 UPS with Integral Battery Cabinets” section of Chapter 3. Refer to Chapter 2, “Unpacking Your Battery Cabinet” for unpacking instructions.

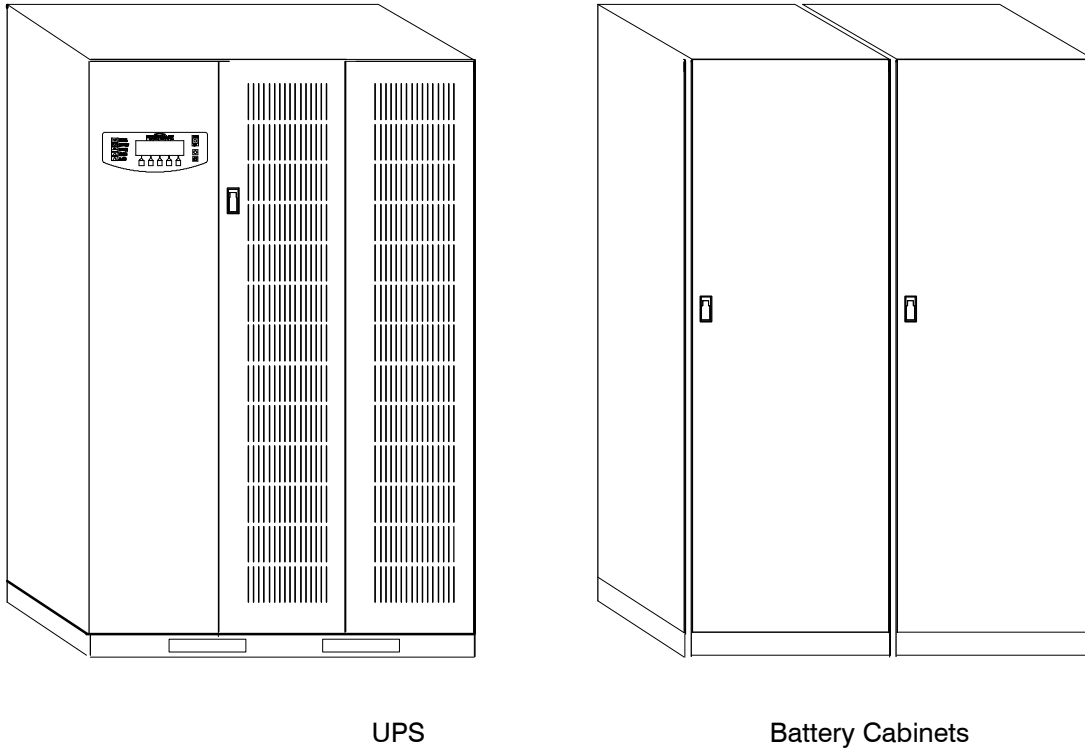

Figure 3. UPS with Separate Battery Cabinets (Attached to Each Other)

For installation instructions, refer to “The Powerware 9350 UPS with Separate Battery Cabinets” section of Chapter 3 or Chapter 4. Refer to Chapter 2, “Unpacking Your Battery Cabinet” for unpacking instructions.

For More Information

This manual describes how to install your battery cabinet. For more information about the operation and communications capabilities of your UPS system, refer to the following:

164201407

Powerware® 9350 (100 kVA – 160 kVA) UPS Installation

Describes the UPS installation procedure; discusses optional accessories, environmental considerations, weight and point loading, connection diagrams, and information on other optional cabinets.

Also describes the UPS Cabinet Control Panel and Monitor Panel, and explains the functions of the UPS; discusses the standard features of the UPS and optional accessories; provides procedures for starting and stopping the UPS, and information about maintenance and responding to system events.

Contact your local Powerware Corporation Field Service office for information about how to obtain copies of these manuals.

Getting Help

If you have a question about any of the information in this manual, or if you have a question this manual does not answer, please call the Powerware Corporation Field Service office:

United States

1-800-843-9433

Canada

1-800-461-9166

Outside the U.S.

Call your local representative

2

Unpacking Your Battery Cabinet

Each Powerware 9350 Series 685 or Series 1085 Battery Cabinet is shipped on a separate pallet. Use a forklift or pallet jack to move the packaged cabinets to the installation site, or as close as possible to the site, before you unload them from the pallets.

Battery cabinets must be installed in accordance with all applicable codes and regulations, including the National Electrical Code (NEC), Article 480.

NOTE: *Startup and operational checks should be performed only by authorized service personnel. This service is offered as part of the sales contract for your battery system.*

Preparing Your Site

The basic environmental requirements for the battery system are:

Ambient Temperature Range: 10–40°C (50–104°F)

Recommended Operating Range: 20–25°C (68–77°F)

Maximum Relative Humidity: 95% noncondensing

The Series 685 or Series 1085 Battery Cabinets use convection cooling to regulate internal component temperature. Air inlets are in the bottom and top of the cabinets. You must allow a minimum clearance of 305 mm (12 in.) above each cabinet for proper air circulation. Additionally, a clearance of 915 mm (36 in.) must be provided in front of the cabinet for component removal and maintenance. Maintaining this clearance provides adequate airflow to the front of the cabinet.

Environmental Considerations

The life of the battery system is adversely affected if the installation does not meet these guidelines:

- The battery cabinet must be installed on a sealed concrete pad or a sealed concrete floor, or on a raised computer room floor.
- The battery cabinet must be installed in a dust-free, nonconductive environment.
- The battery cabinet must be installed in a humidity-controlled environment.

Preparing for Wiring the Battery Cabinet

For external wiring requirements, including the minimum AWG size of external wiring, refer to Appendix A, Table C.

Inspecting and Unpacking Each Cabinet

The first task in preparing for installation is inspecting and unpacking each cabinet. Cabinets arrive covered with protective packaging material, as shown in Figure 4.

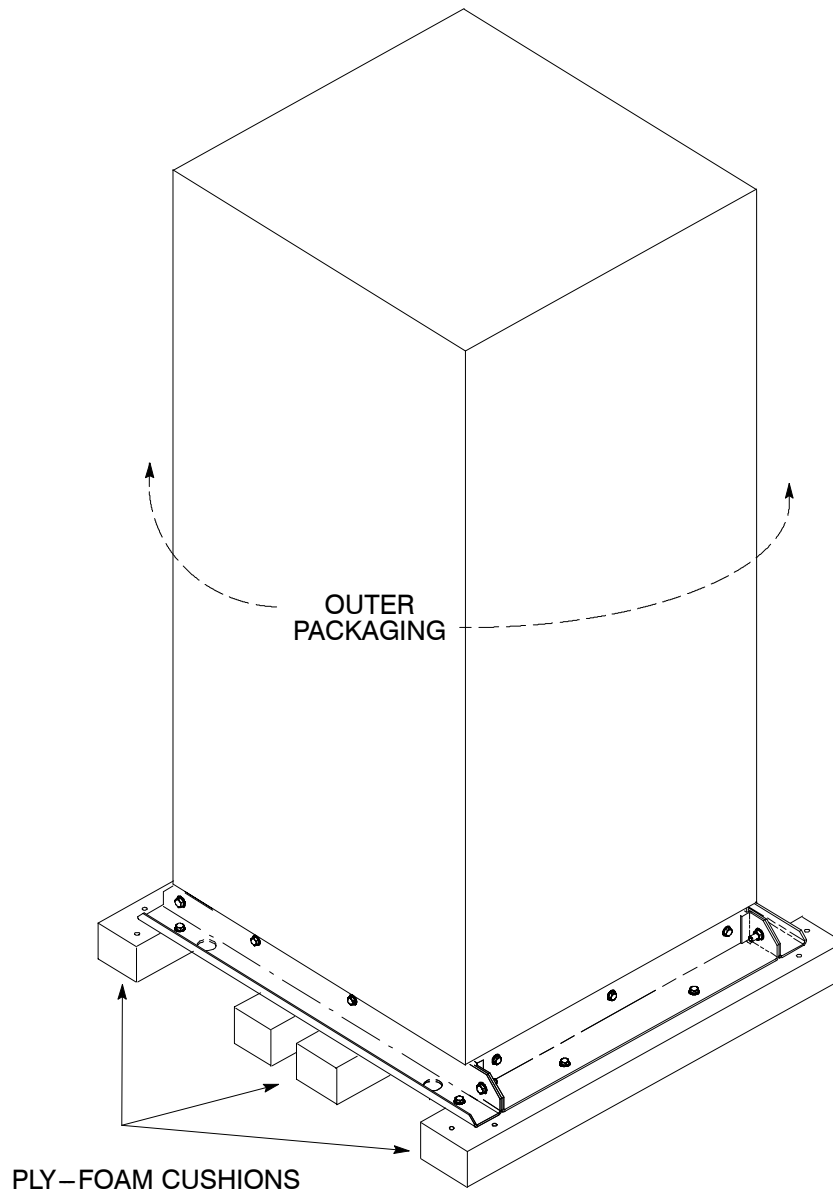

Figure 4. Cabinet as Shipped, with Outer Packaging and Pallet

1. Carefully inspect the outer packaging for evidence of damage during transit.

CAUTION:
DO NOT INSTALL A DAMAGED CABINET. REPORT ANY DAMAGE TO THE CARRIER. CONTACT YOUR LOCAL SALES OR SERVICE OFFICE IMMEDIATELY.

2. Use appropriate material handling equipment to move the cabinet to a convenient unpacking area. Space is provided between the pallets to insert pallet jack blades on the bottom of the unit.

DANGER:
RISK OF INSTABILITY. DO NOT TILT CABINETS MORE THAN 10 DEGREES FROM VERTICAL OR THE CABINET MAY TIP OVER.

3. Set each pallet on a firm, level surface, allowing a minimum clearance of 4.6m (15 ft) on each side for removing the cabinets from the pallets.
4. Cut and remove the steel bands around each cabinet.
5. Remove the protective cardboard covering from the cabinets by vertically cutting one corner, using a knife blade no longer than 25 mm (1 in.).
6. Remove the corrugated corner protectors, box, plastic bag, and discard or recycle them in a responsible manner.

CAUTION:
IF YOU CAN SEE DAMAGE IN OR ON A CABINET, DO NOT INSTALL IT. REPORT ANY DAMAGE TO THE CARRIER. CONTACT YOUR LOCAL SALES OR SERVICE OFFICE IMMEDIATELY.

Unloading the Battery Cabinet from the Pallet

The battery cabinet is bolted to a pallet consisting of four angle metal supports secured to laminated plywood/foam cushions. The foam cushions act as shock absorbers for the cabinet during shipment.

1. Remove the doors. Remove the retaining screw located inside each door at the bottom hinge pivot point, then lift the door off. Save the retaining screws for reinstallation of the doors.
2. Locate the field kit (packed inside of the cabinet). Locate the four 1/2 in. jacking bolts and install them in the threaded holes in the front and rear supports. Place a floor protector underneath each jacking bolt, and screw the bolts down against them. The floor protectors protect the floor from being marred by the jacking bolts.

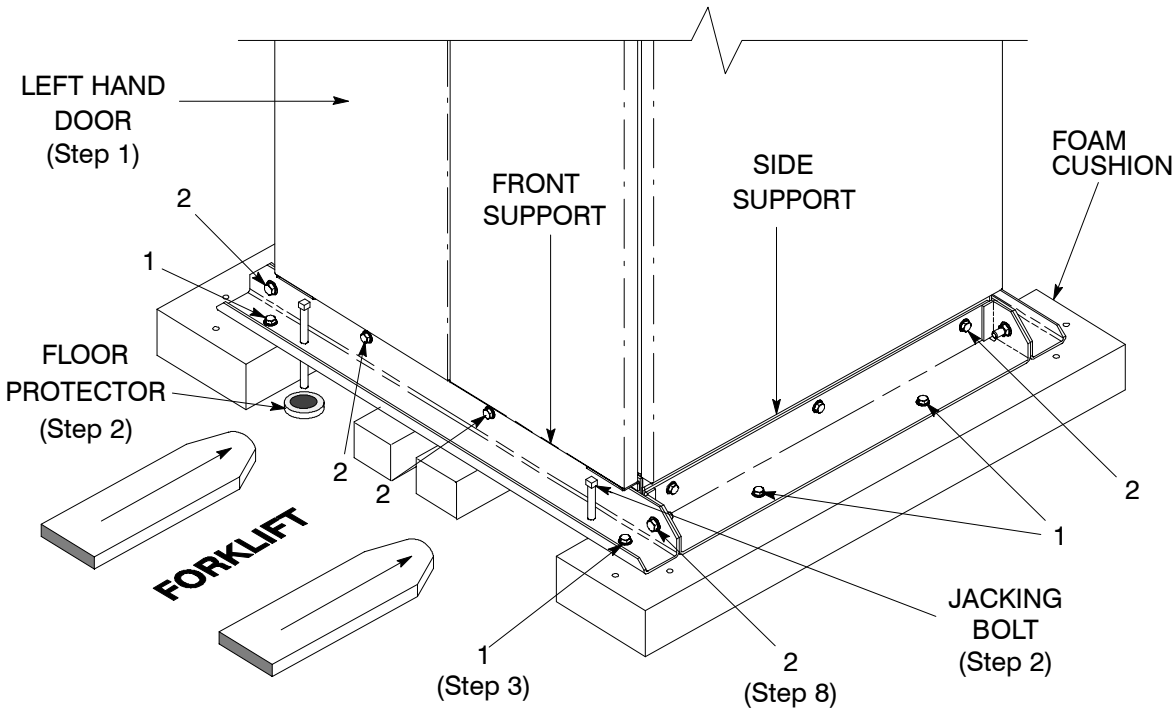

Figure 5. Removing Front and Rear Supports

3. Loosen, but do not remove, the hardware holding the foam cushions to the front and rear supports (labeled “1” in Figure 5).

**WARNING: SERIOUS INJURY MAY OCCUR!
BATTERY CABINETS ARE EXTREMELY HEAVY. IF UNLOADING INSTRUCTIONS
ARE NOT CLOSELY FOLLOWED, CABINET MAY TIP.**

4. Turn each jacking bolt consecutively, two full turns, until the foam cushions clear the floor by approximately 3 mm (1/8 in.).

**DANGER: RISK OF INSTABILITY!
TURNING THE JACKING BOLTS UNEVENLY MAY CAUSE THE CABINET TO
BECOME UNBALANCED. TO PREVENT TIPPING THE CABINET, RAISE AND
LOWER THE JACKING BOLTS EVENLY.**

**DANGER: CABINET MAY TIP!
THE BATTERY CABINET SHOULD ONLY BE RAISED APPROXIMATELY 3 mm
(1/8 in.) ABOVE THE FLOOR (JUST ENOUGH TO ALLOW REMOVAL OF THE
FOAM CUSHIONS).**

5. After the foam cushions clear the floor, remove the hardware loosened in Step 3. Pull the foam cushions out from under the battery cabinet. Please discard or recycle them in a responsible manner.

DANGER: CABINET MAY FALL!
DO NOT LOOSEN THE HARDWARE ATTACHING THE SIDE OR FRONT SUPPORTS TO THE CABINET BASE, OR THE FRONT AND SIDE SUPPORTS TO EACH OTHER, AT THIS TIME.
THE CABINET MUST BE LOWERED BY THE JACKING BOLTS BEFORE THE SUPPORTS CAN BE REMOVED.

6. Carefully and evenly lower the cabinet by turning each jacking bolt consecutively two full turns (maximum) until the supports contact the floor, and the cabinet is no longer supported by the jacking bolts.
7. After the battery cabinet is resting on the floor, remove the jacking bolts and discard or recycle them in a responsible manner.
8. Remove the hardware, labeled “2” in Figure 5, holding the front, rear and side supports to the cabinet base. Discard or recycle the hardware and support brackets in a responsible manner.
9. Replace the doors that were removed in Step 1. The battery cabinet is now ready to be rolled to its final location.
10. Repeat Steps 1 through 9 for each cabinet you are preparing to install.

Creating an Installation Plan

Before beginning to install your battery cabinet, you should be sure that you understand the portions of this manual that apply to your system. Use the procedures and illustrations in the following sections to create a logical plan for installing the battery cabinet you purchased. Refer to Chapter 3, “*Connecting to Powerware 9350 30–160*” to help plan your installation.

NOTES:

3

Connecting to Powerware 9350 30–160

The method you use to install your battery cabinets depends on which UPS you have. For the purpose of discussion, this chapter uses the term *UPS* to refer to the UPS cabinet, and the term *battery cabinet* to refer to any battery cabinet. There are two different sizes of battery cabinets, but the procedure for connecting the cabinets to your UPS system is the same.

- Joining one or more battery cabinets to the UPS
- One or more battery cabinets separately located from the UPS.

The Powerware 9350 UPS with Integral Battery Cabinets

Use this procedure to attach a Powerware 9350 Series 685 or Series 1085 Battery Cabinet to any Powerware 9350 UPS cabinet (see Figure 6).

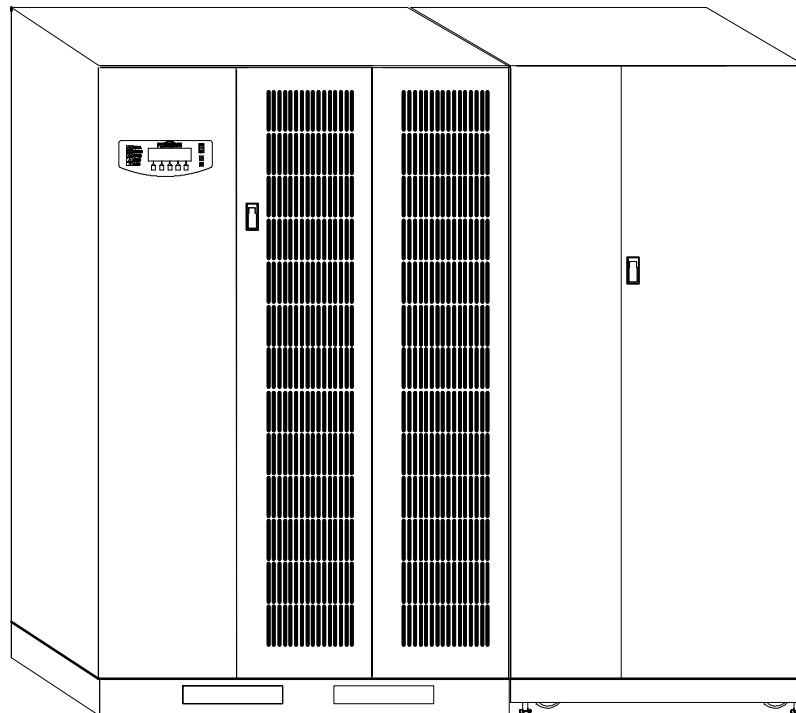

Figure 6. UPS with Integral Battery Cabinet

1. Make sure that the UPS is properly installed and secured with its leveling feet.
2. Roll the battery cabinet to a spot near the right-hand side of the UPS, as shown in Figure 7.
3. The field kit is attached with cable ties to the frame inside the door. Remove and retain the field kit for later use.
4. If necessary, remove the cosmetic covers and hanger brackets from the right-hand side of the UPS. Save covers, screws, and brackets for later reuse.
5. Push the battery cabinet toward the UPS cabinet until the doors are flush with each other.
6. Three cabinet attachment brackets are provided for securing each cabinet at the top and bottom. Two flat brackets join the tops of the cabinets, one at the front and one at the back. A larger flat bracket joins the cabinets at the bottom. Attach the flat brackets to the cabinet tops first.
7. For Series 685 Battery Cabinets, remove the right-hand screw from the top right door hinge of the UPS cabinet. Align the hole in one flat bracket over this screw hole, and the other hole over the hole in the top of the battery cabinet. Replace the screw in the hinge, and attach the other end of the bracket to the top of the battery cabinet using an M4 × 10 hex screw from the field kit (see Figure 7).
8. For Series 1085 Battery Cabinets, remove the right-hand screw from the top right door hinge of the UPS cabinet, and the right-hand screw from the top left door hinge of the battery cabinet. Align the holes in the flat bracket over these screw holes and then replace the screws in the hinges (see Figure 7).
9. Align the holes in the other small flat bracket with the two holes in the top rear of the UPS and the battery cabinet. Attach each end to its mating hole using an M4 × 10 hex screw from the field kit (see Figure 7).

NOTE: Perform Steps 10 through 13 for the Series 1085 Battery Cabinet.
Perform Steps 14 through 18 for the Series 685 Battery Cabinet.

10. Locate the large flat bracket from the field kit. Place one end of the bracket over the stud on the bottom side of the UPS cabinet lower right-hand hinge, and the other end over the stud on the bottom side of the lower right-hand hinge on the Series 1085 Battery Cabinet (see Figure 8).
11. Attach the bracket to the hinges with two M8 self-locking nuts from the field kit.

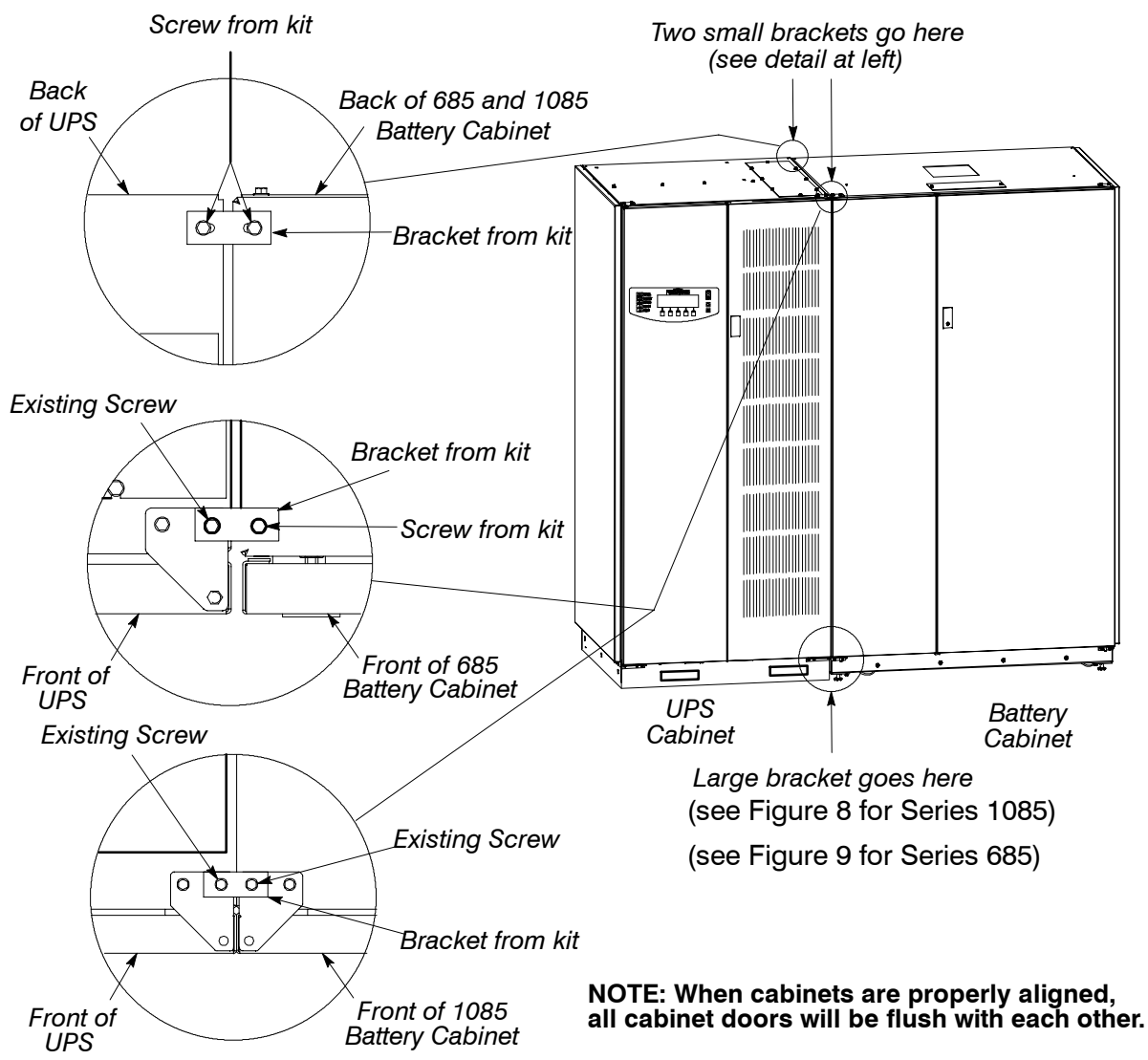

Figure 7. Placement of Attaching Brackets, UPS to Battery Cabinet

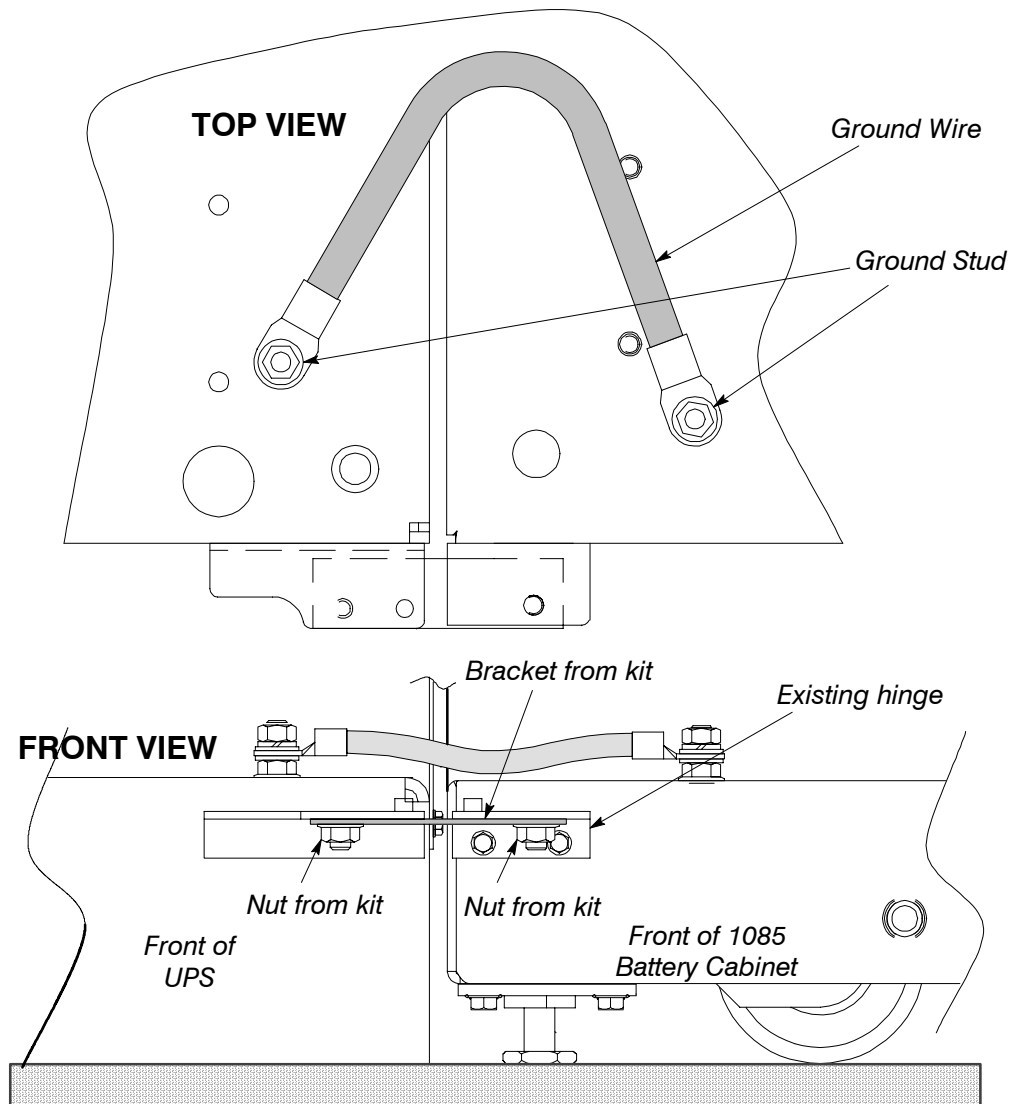

Figure 8. Attaching UPS Base to Series 1085 Base

12. Route the ground wire (from the field kit) from the customer ground stud in the battery cabinet, under the lower right-hand battery tray, through the access hole in the side panel of the UPS, and attach to customer ground stud in the UPS cabinet. Hardware is provided on each ground stud.
13. Repeat Steps 2 through 12 to attach additional Series 1085 Battery Cabinets to the other side of the first battery cabinet. Level the cabinets with the leveling screws.
14. Locate the cabinet connecting bracket from the field kit. Attach the bracket to the lower right-hand side of the Series 685 base using 2 M4 screws.
15. Locate the large flat bracket from the field kit. Place one end of the bracket over the stud on the bottom side of the UPS cabinet lower right-hand hinge, and the other end over the stud on the bottom side of the lower right-hand hinge on the Series 685 Battery Cabinet (see Figure 9).
16. Attach the bracket to the hinges with two M8 self-locking nuts from the field kit.

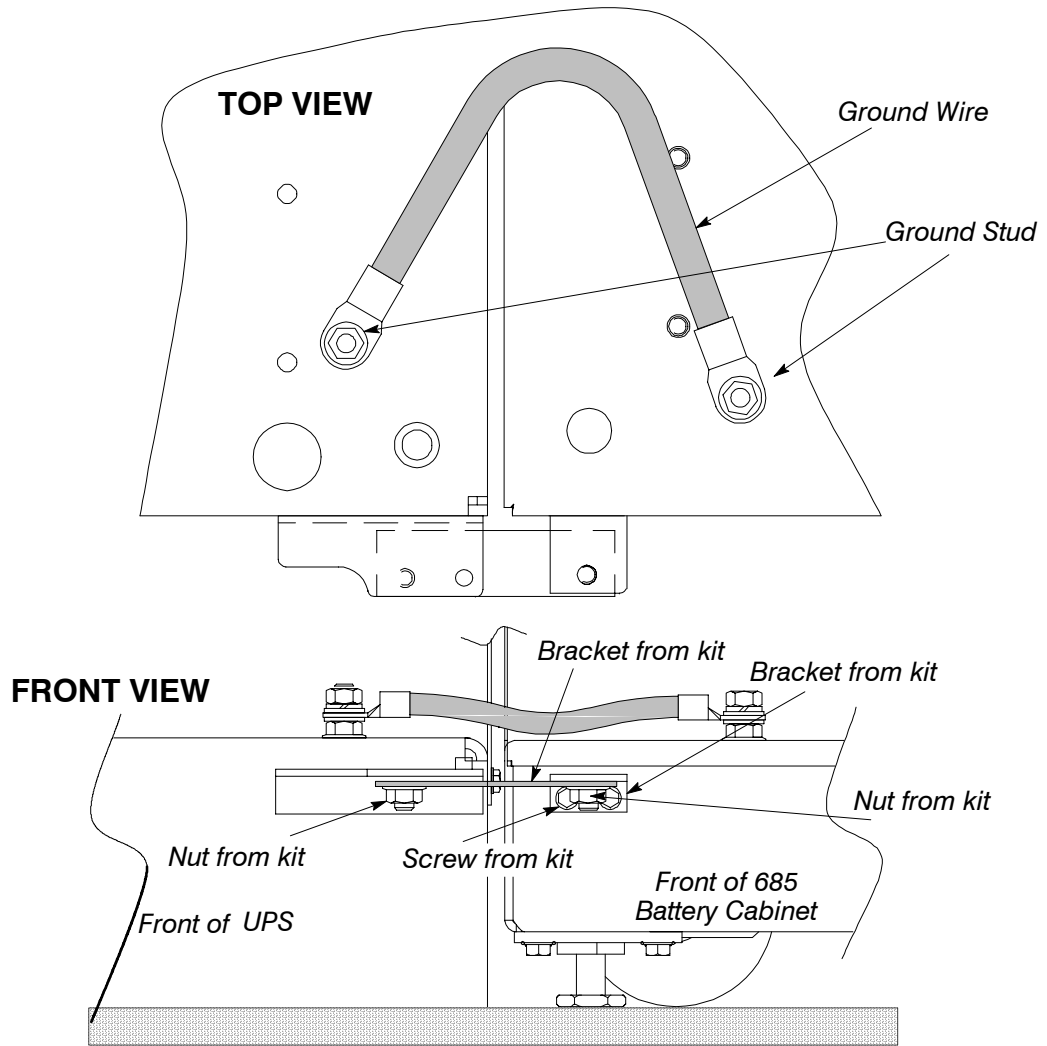

Figure 9. Attaching UPS Base to Series 685 Base

- 17.** Locate the ground wire from the field kit. Route the ground wire from the customer ground stud in the battery cabinet, under the lower right-hand battery tray, through the access hole in the side panel of the UPS, and attach to customer ground stud in the UPS cabinet. Hardware is provided on each ground stud.
- 18.** Repeat Steps 2 through 17 to attach additional Series 685 Battery Cabinets to the other side of the first battery cabinet. Level the cabinets with the leveling screws.

To Electrically Connect Integral Battery Cabinets Together and to the UPS:

1. All battery cabinets will arrive at your site with each battery connection string electrically disconnected. If you are installing more than one battery cabinet, perform Steps 2 through 6 for each cabinet. The battery cabinet adjacent to the UPS will be the only cabinet directly connected to the UPS.

WARNING:
**LETHAL VOLTAGE WILL BE PRESENT WHEN PERFORMING THE REMAINING
STEPS IN THIS SECTION AND SUBSEQUENT SECTIONS.**

2. After making sure that all battery breakers are in the OFF position, connect the string of battery trays together by mating the loose red connector from each tray to the fixed black connector mounted on the front edge of the tray above it (see Figure 10 for Series 685 and Figure 13 for Series 1085).
3. Find the red (positive) and black (negative) cables supplied coiled inside the cabinet. These cables are provided half-stripped to facilitate attaching to the lugs in the cabinet. Use double pole compression lugs to secure the wires to the unit terminal blocks.
4. Wire the UPS to the Battery cabinet by attaching the provided cable from E4(+) to “DC+” and E5(–) to “DC–” power interconnection cables provided. The provided red(+) and black(–) cables are already cut to length.
5. Remove the cable tie securing the battery breaker sensing cable.
6. Locate the battery breaker sensing cable in the right-hand Battery cabinet. Route this connector into the cabinet to the immediate left and mate with the matching connector in the bottom of that cabinet. Connect all battery cabinets together this way.
7. Locate control harness with semi-stripped ends in Battery cabinet. Connect this to the CUSTTB terminal strip in the UPS. Route the battery cable to the immediate right and mate with the matching connector in the bottom of the UPS cabinet.
8. Repeat Steps 2 through 7 for each battery cabinet to be joined.
9. Mount the side panel to the side of the right-hand battery cabinet:
 - a. Mount the hanger brackets to the top side of the right-hand battery cabinet using M4 screws (see Figure 11).
 - b. Hang the side panel on the hanger brackets and align with the front and rear of the battery cabinet.
 - c. Secure the side panel at the bottom using M4 hex head screws.
10. Secure all battery cabinets by closing and latching the doors.
11. Secure the UPS by reinstalling safety shields and closing and latching the doors.

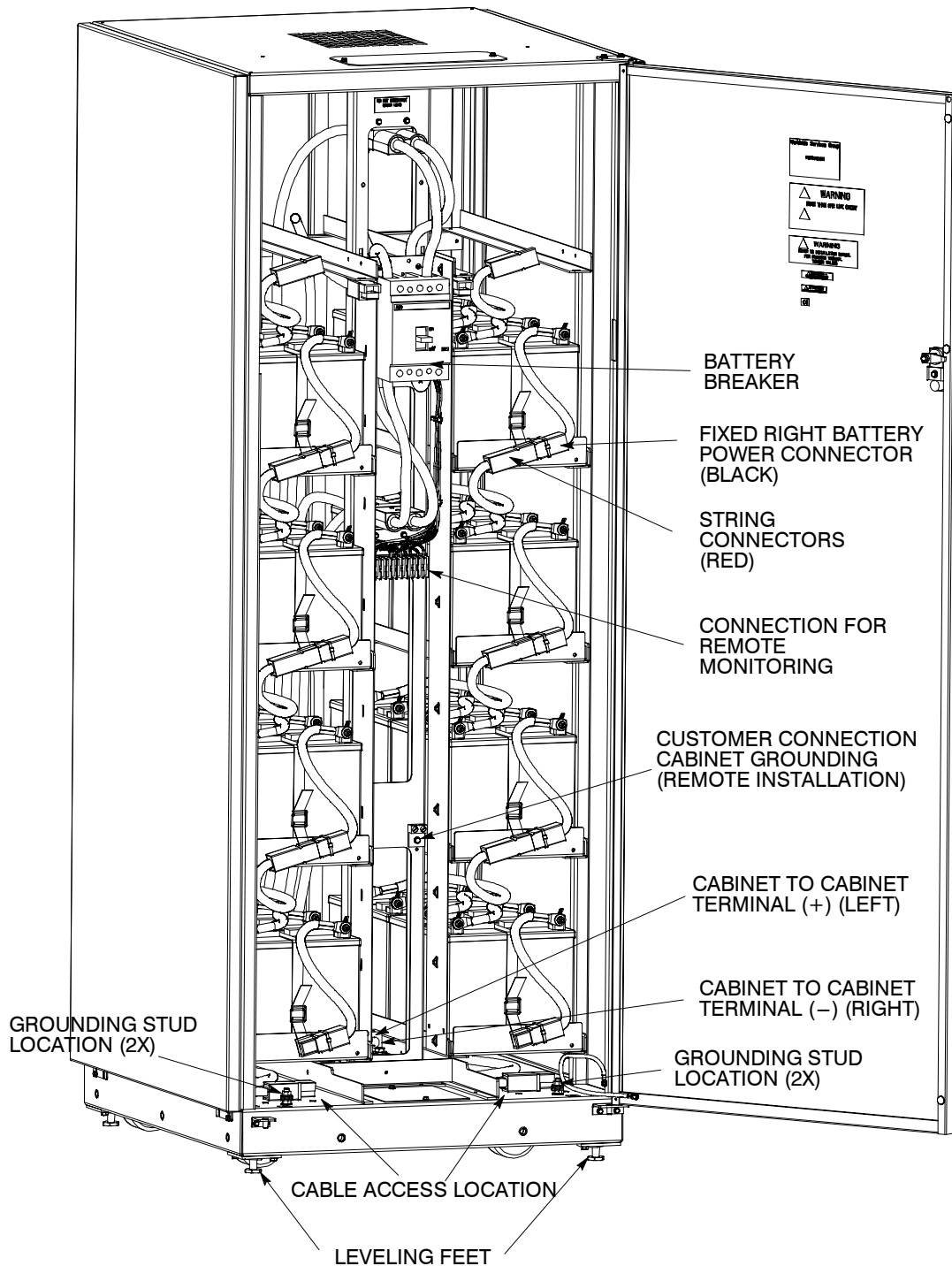

Figure 10. Series 685 Battery Cabinet Wiring Detail

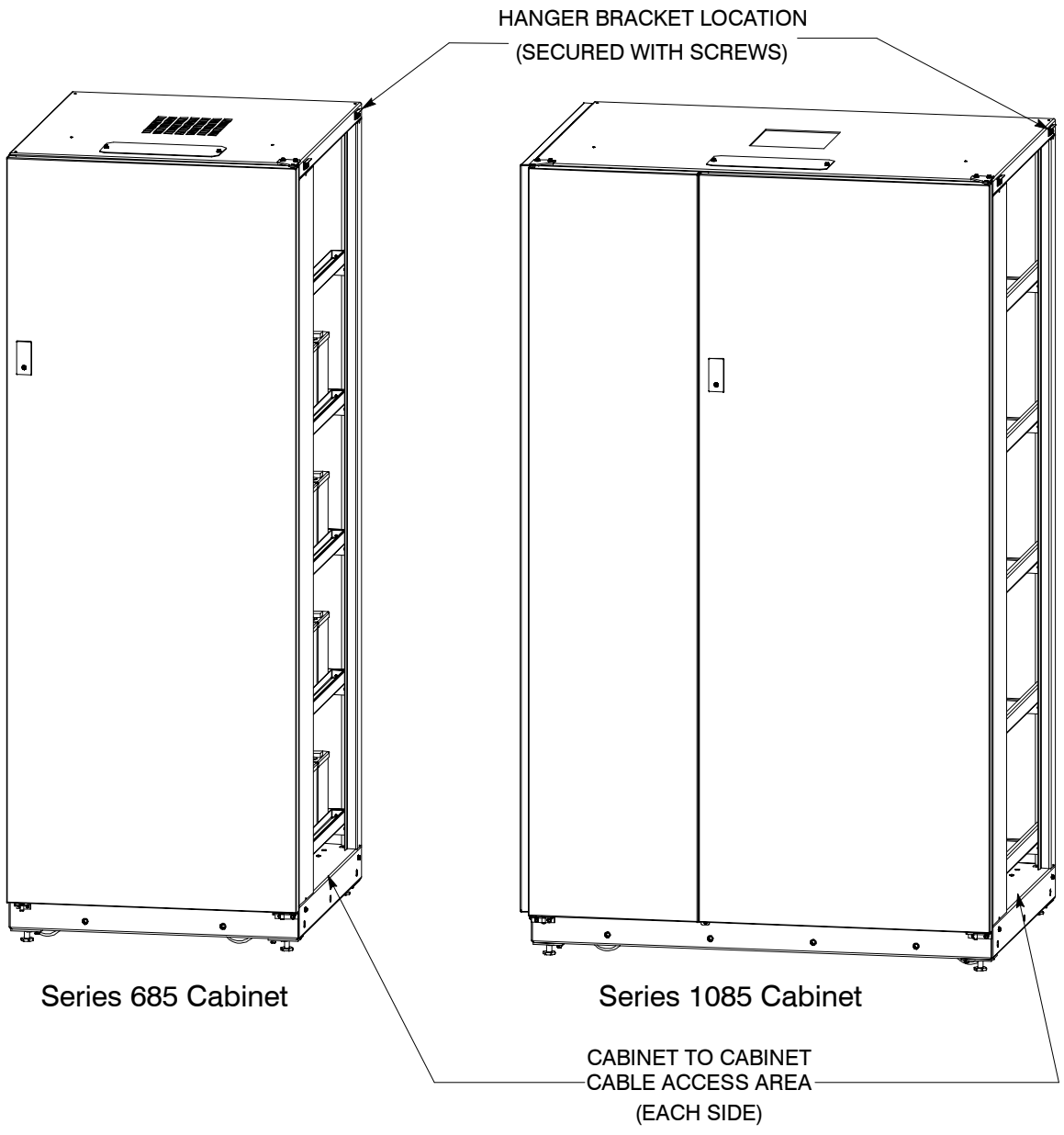

Figure 11. Series 685 and 1085 Battery Cabinet Hanger Brackets

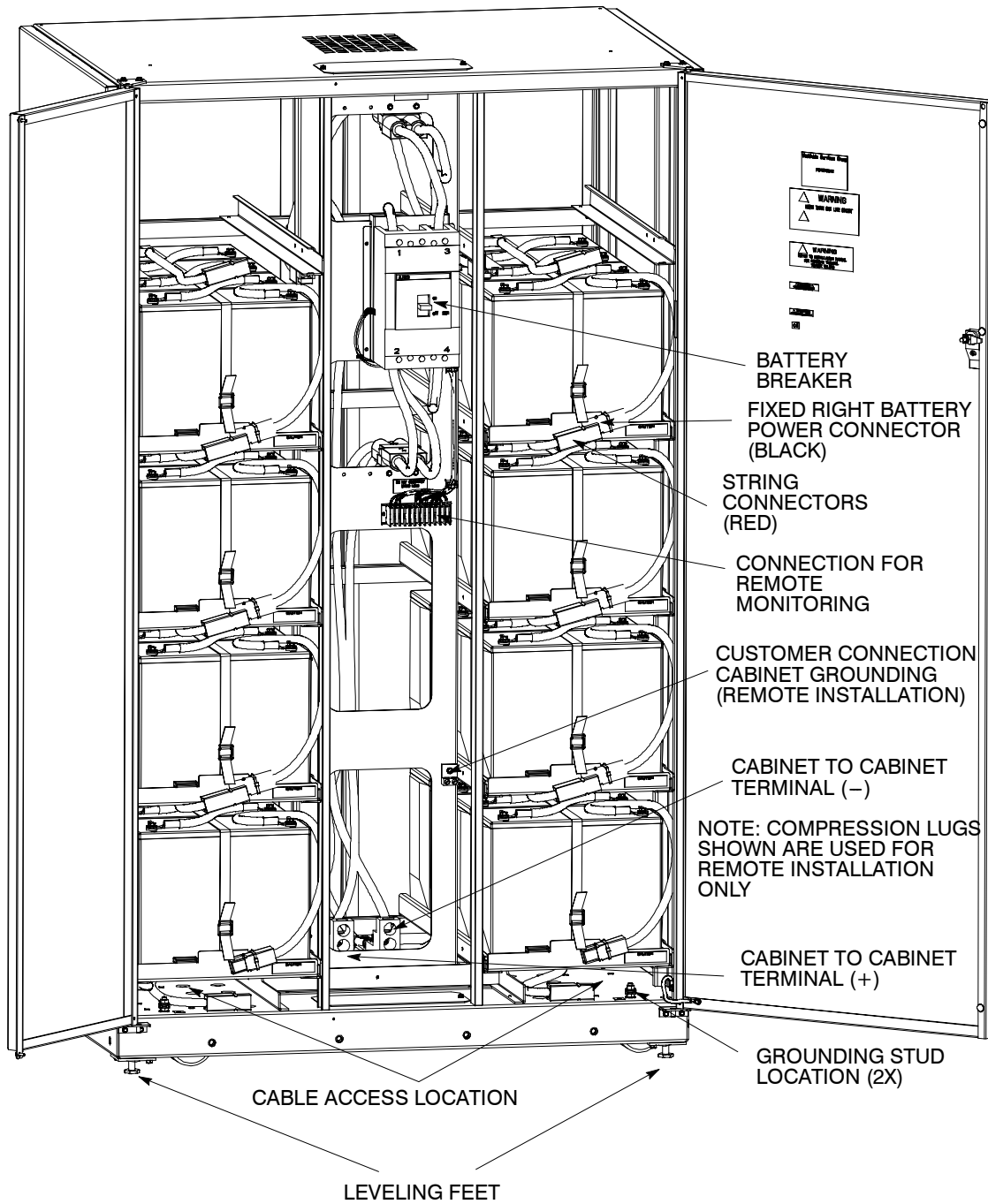
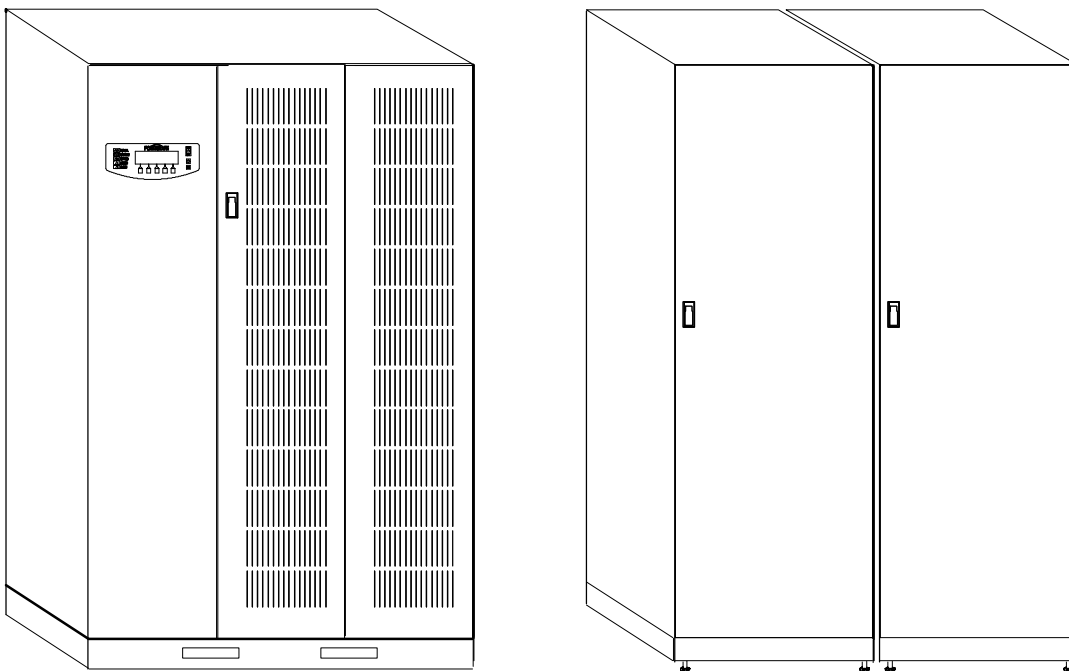

Figure 12. Series 1085 Battery Cabinet Wiring Detail

Powerware 9350 UPS with Separately Located Battery Cabinets

Use this procedure to wire a separately located Series 685 or Series 1085 Battery Cabinet to any Powerware 9350 UPS cabinet (see Figure 14).



In this situation, the Battery cabinets are remotely located from the UPS and are lineup and match with each other.

Figure 13. UPS with Separately Located Battery Cabinets

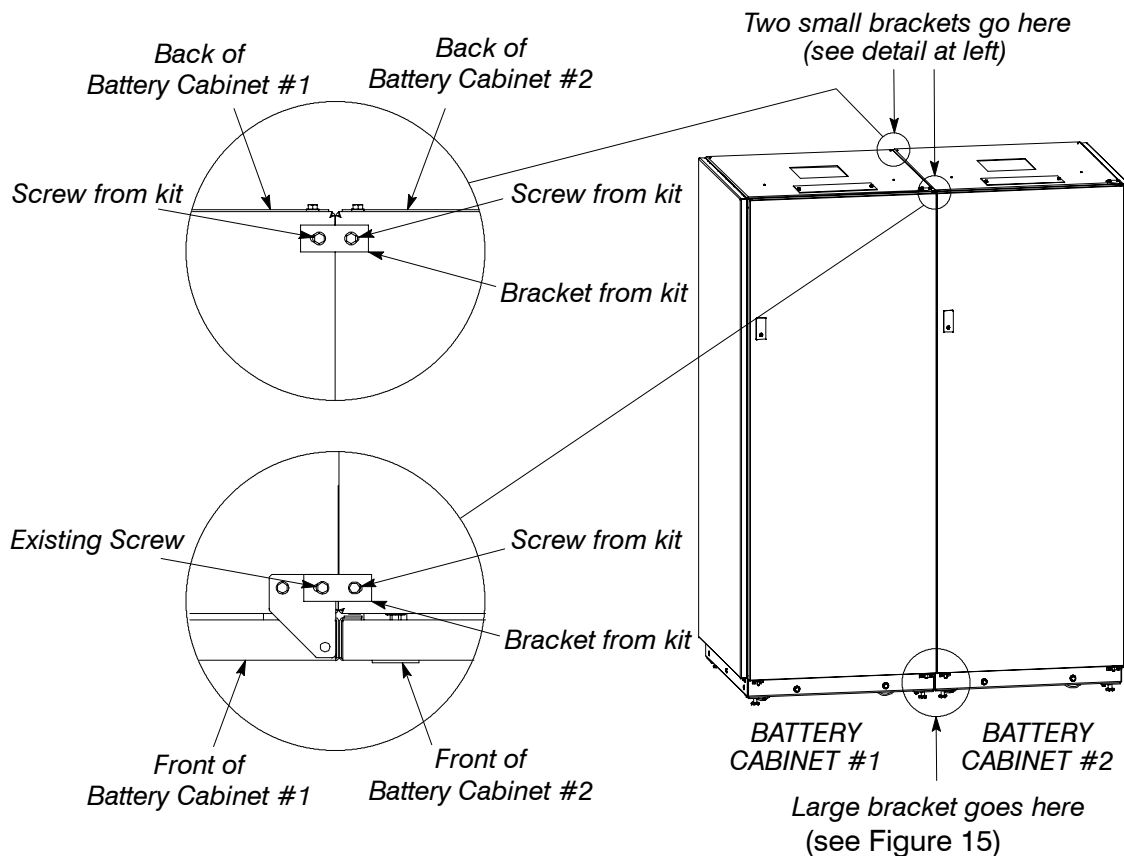

NOTE: When cabinets are properly aligned, all cabinet doors will be flush with each other.

Figure 14. Placement of Joining Brackets (Two or More Series 685 Battery Cabinets)

Separate Installation of Series 685 Battery Cabinets

1. Remove the right-hand screw from the top door hinge of battery cabinet #1. Align the hole in one flat bracket over this screw hole, and the other hole over the hole in the top of battery cabinet #2. Replace the screw in the hinge, and attach the other end of the bracket by using an M4 × 10 hex screw from the field kit (see Figure 14).
2. Align the holes in the other small flat bracket with the two holes in the top rear of battery cabinets #1 and #2. Attach each end to its mating hole using an M4 × 10 hex screw from the field kit (see Figure 14).

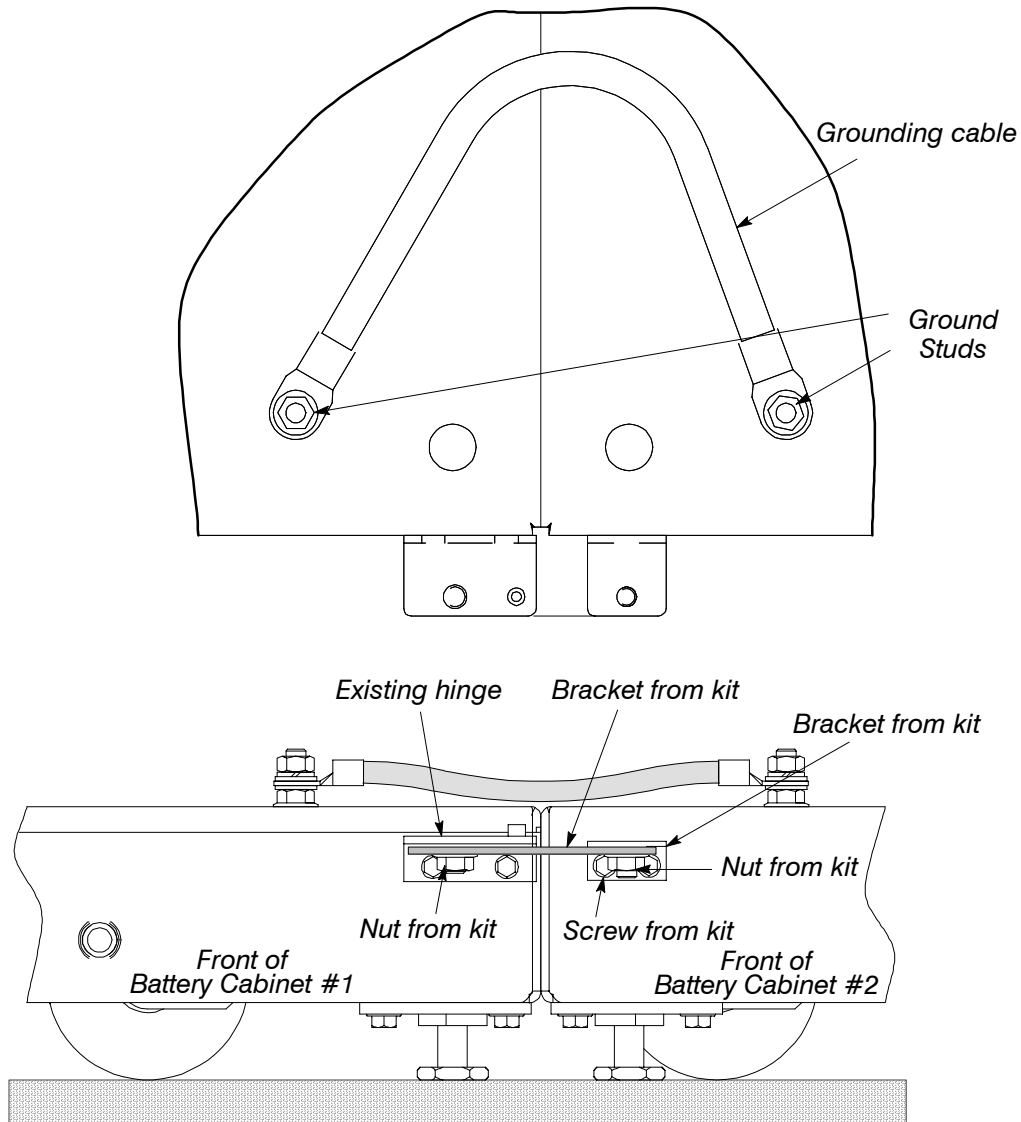
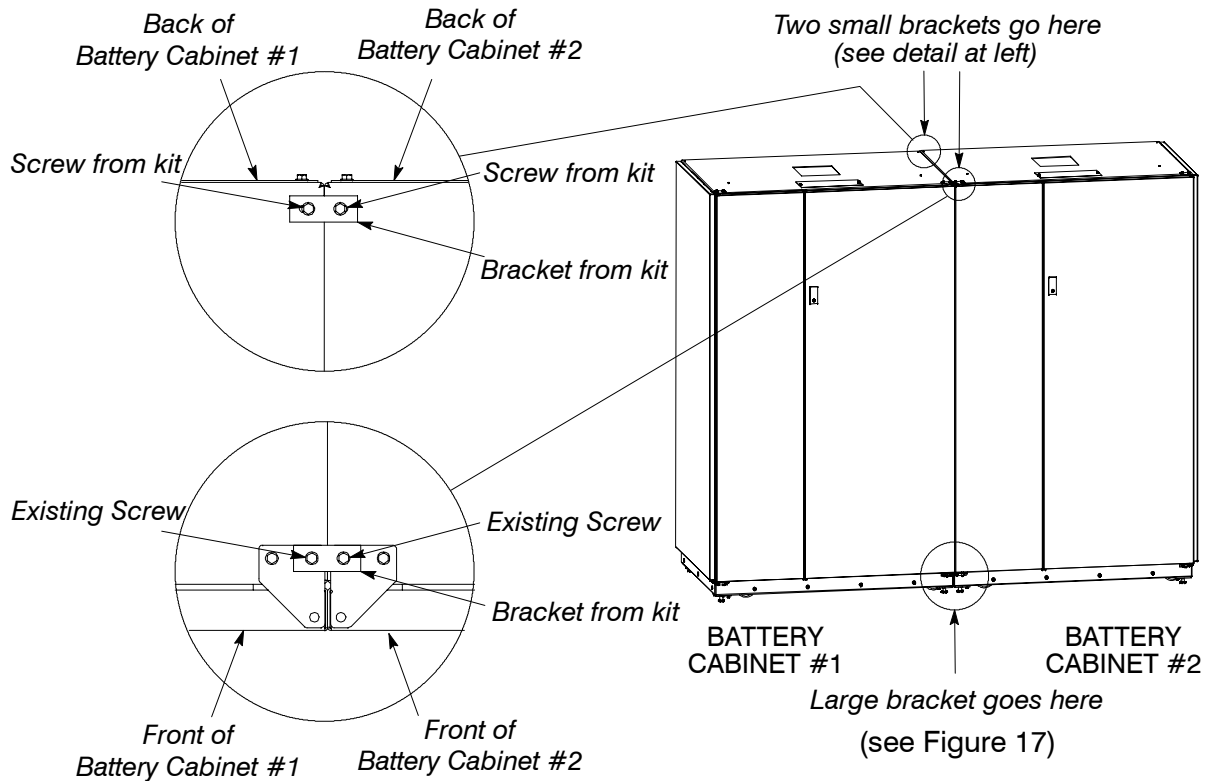

Figure 15. Connecting Two Series 685 Bases

- 3.** Locate the cabinet connecting bracket and two M4 × 10 hex head screws from the field kit. Attach the bracket to the lower right-hand side of battery cabinet #2 using the two screws (see Figure 15).
- 4.** Locate the large flat bracket from the field kit. Place the bracket over the stud on the bottom side of battery cabinet #1 lower hinge, and over the stud on the bottom side of the cabinet connecting bracket on battery cabinet #2. Attach the bracket with two M8 self-locking nuts from the field kit (see Figure 15).
- 5.** Locate the ground wire from the field kit. Route the ground wire from the customer ground stud in battery cabinet #1, under the lower right-hand battery tray, into the cable access area in battery cabinet #2, and attach to customer ground stud. Hardware is provided on each ground stud.
- 6.** Repeat Steps 1 through 5 to join additional Series 685 Battery Cabinets together.



NOTE: When cabinets are properly aligned, all cabinet doors will be flush with each other.

Figure 16. Placement of Joining Brackets (Two or More Series 1085 Battery Cabinets)

Separate Installation of Series 1085 Battery Cabinets

1. Remove the right-hand screw from the top door hinge of battery cabinet #1. Align the hole in one flat bracket over this screw hole, and the other hole over the hole in the top of battery cabinet #2. Replace the screw in the hinge, and attach the other end of the bracket by using an M4 × 10 hex screw from the field kit (see Figure 16).
2. Align the holes in the other small flat bracket with the two holes in the top rear of battery cabinets #1 and #2. Attach each end to its mating hole using an M4 × 10 hex screw from the field kit (see Figure 16).

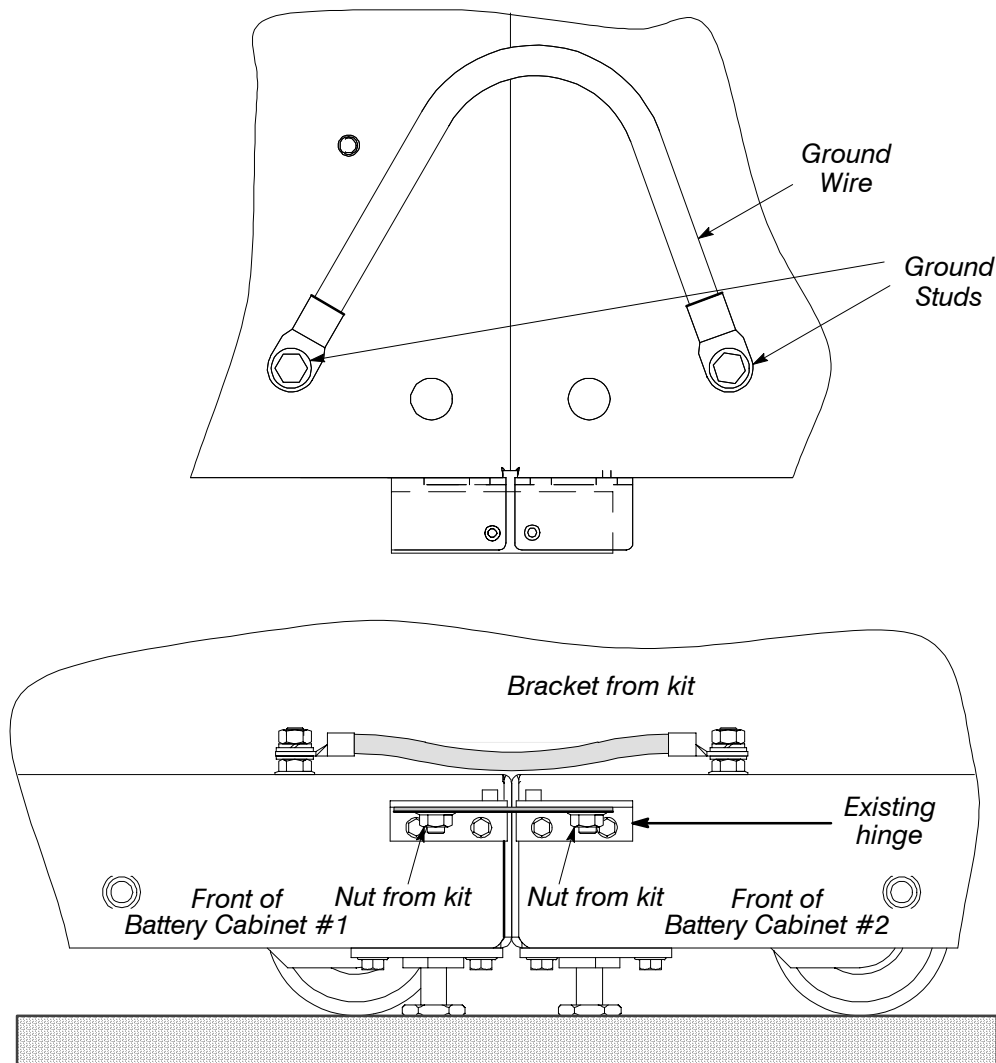

Figure 17. Connecting Two Series 1085 Bases

- 3.** Locate the large flat bracket from the field kit. Place the bracket over the stud on the bottom side of battery cabinet #1 lower hinge, and over the stud on the bottom side of battery cabinet #1 lower hinge. Attach the bracket with two M8 self-locking nuts from the field kit (see Figure 17).
- 4.** Locate the ground wire from the field kit. Route the ground wire from the customer ground stud in battery cabinet #1, under the lower right-hand battery tray, into the cable access area in battery cabinet #2, and attach to customer ground stud. Hardware is provided on each ground stud.
- 5.** Repeat Steps 1 through 4 to join additional Series 1085 Battery Cabinets together.

To Electrically Connect Separate Battery Cabinets to the UPS:

1. All battery cabinets will arrive at your site with each battery connection string electrically disconnected. If you are installing more than one battery cabinet, perform Steps 2 through 6 for each cabinet. Battery cabinet #1 (the left-hand cabinet) will be the only cabinet directly connected to the UPS.

WARNING:
**LETHAL VOLTAGE WILL BE PRESENT WHEN PERFORMING THE REMAINING
STEPS IN THIS SECTION AND SUBSEQUENT SECTIONS.**

2. After making sure that all battery breakers are in the OFF position, connect the string of battery trays together by mating the loose red connector from each tray to the fixed black connector mounted on the front edge of the tray above it (see Figure 10 for Series 685 and Figure 13 for Series 1085 for location of all items discussed in this section).
3. Find the red (positive) and black (negative) cables supplied coiled inside the cabinet. These cables are provided half-stripped to facilitate attaching to the lugs in the cabinet. Use double pole compression lugs to secure the wires to the unit terminal blocks.
4. Remove the cable tie securing the battery breaker sensing cable.
5. Locate the battery breaker sensing cable in the right-hand battery cabinet. Route this connector into the cabinet to the immediate left and mate with the matching connector in the bottom of that cabinet. Connect all battery cabinets together this way.
6. Repeat Steps 2 through 5 for each battery cabinet to be joined.
7. Route cables from positive (+) and negative (–) terminals in the bottom of battery cabinet #1 through conduit (top or bottom entry) to terminals E4 and E5 of the UPS cabinet. See Figure 10 or Figure 12 for location of positive (+) and negative (–) terminals.
 - a. Refer to Appendix A, Table C to size wire for connecting the battery cabinets to the remotely located UPS cabinet.
 - b. See Drawing 164201408–1 in Appendix A for Series 685 Battery Cabinet top or bottom conduit landing locations.
 - c. See Drawing 164201408–2 in Appendix A for Series 1085 Battery Cabinet top or bottom conduit landing locations.
 - d. See Installation Manual 164200253 for Powerware 9350 30–80 kVA top or bottom conduit landing locations.
 - e. See Installation Manual 164200292 for Powerware 9350 100–160 kVA top or bottom conduit landing locations. The conduit landing plates are removable to add conduit landing holes as required. The conduit landing plates should be removed when holes are added to keep metal particles from falling inside the battery cabinet.
 - f. Refer to Chapter 5, Table C for remote battery disconnect circuit breaker information.

- 8.** Mount the side panels to the sides of the first and last battery cabinets:
 - a.** Mount the hanger brackets to the top side of the battery cabinets using M4 screws (see Figure 11).
 - b.** Hang the side panel on the hanger brackets and align it with the front and rear of the battery cabinet.
 - c.** Secure the side panel at the bottom using M4 hex head screws.
- 9.** Secure all battery cabinets by closing and latching the doors.
- 10.** Secure the UPS by reinstalling safety shields and closing and latching the doors.

Completing the Installation Checklist

The final step in installing your battery cabinet is to complete the Installation Checklist. This checklist ensures that you have installed all hardware, cables, and other equipment. Completing all items on the checklist will ensure a smooth installation. Make a copy of the Installation Checklist before filling it out, and retain the original.

After completing your installation, a service representative will be able to verify the operation of your battery cabinet, and commission it to support your critical load. The service representative cannot perform any installation tasks other than verifying that the battery cabinet has been correctly installed. Service personnel may request a copy of the completed Installation Checklist to be sure you have completed all applicable equipment installation requirements.

NOTE:

The Installation Checklist **MUST** be completed prior to starting up the UPS system for the first time.

Installation Checklist for Powerware 9350 30 through 160

- All packing materials and restraints have been removed from each cabinet.
- Each cabinet in the battery system is placed in its correct location.
- All cabinets are bolted together.
- A ground wire is installed between all cabinets that are bolted together.
- All conduits and cables are properly routed to the battery cabinets.
- A ground conductor is properly installed.
- Battery cables and harness are terminated on the K2 battery contactor E4 and E5 in the UPS cabinet.
- Internal battery cabinet connections have been completed (bus bars, plugs, etc.)
- Air conditioning equipment is installed and operating correctly.
- The area around the installed battery system is clean and dust-free.
(It is recommended that the battery cabinet be installed on a sealed concrete pad or a sealed concrete floor.)
- Adequate working area exists around the battery cabinet and other cabinets.
- Adequate lighting is provided around all battery cabinet equipment.
- A remote battery disconnect control is mounted in its installed location and its wiring is terminated inside the battery cabinet (OPTIONAL).

This Page Intentionally Left Blank.

4

Connecting to Powerware 9350–80 and 160

This chapter will explain how to electrically connect your battery cabinets to your Powerware 9350–80 or 160 UPS.

Figure 18 details the Battery cabinet DC connections and control wiring connection point in a Powerware 9350–80 UPS. Figure 19 details the same connections in a Powerware 9350–160 UPS.

NOTE: See Table C in Appendix A for sizing wire for separate battery configurations.

There are no battery cabinet-to-UPS mechanical attachment requirements for this type of system. However, individual battery cabinets should be attached and grounded to each other. Please refer to later sections of this chapter for instructions on these procedures.

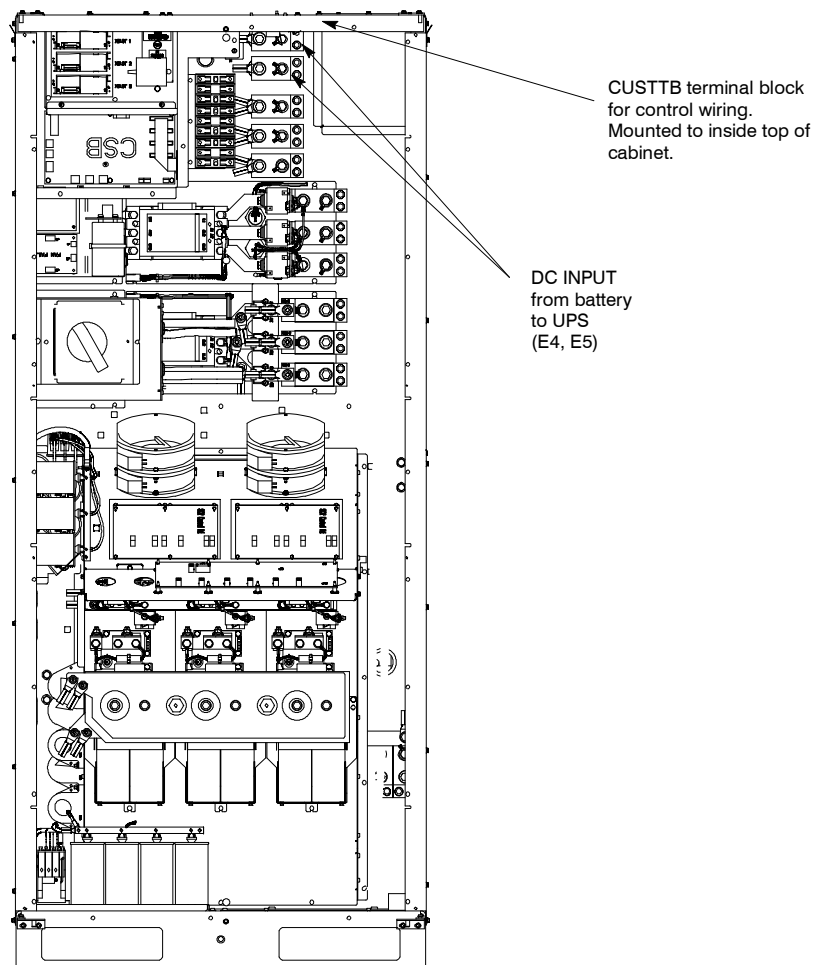

Figure 18. Battery Connections for a Powerware 9350–80

Powerware 9350–80 or 160 with Separate Battery Cabinets

1. Make sure that the UPS is properly installed and secured.
2. Roll the battery cabinets to their permanent location.
3. Attach and connect the battery cabinets to each other (refer to “The Powerware 9350 UPS with Separate Battery Cabinets” section of Chapter 3).
4. If necessary, remove the cosmetic covers and doors from the UPS. Save covers, screws, and brackets for later reuse.
5. Each battery cabinet in your system will have to be individually connected to terminals E4 and E5.
6. Route cables from positive (+) and negative (–) terminals in the bottom of each battery cabinet through conduit (top or bottom entry) to terminals E4 and E5 of the UPS cabinet. See Figure 18 or 19 for location of terminals E4 and E5. Refer to Chapter 3, Figure 11 or Figure 13 for location of battery cabinet positive (+) and negative (–) terminals.

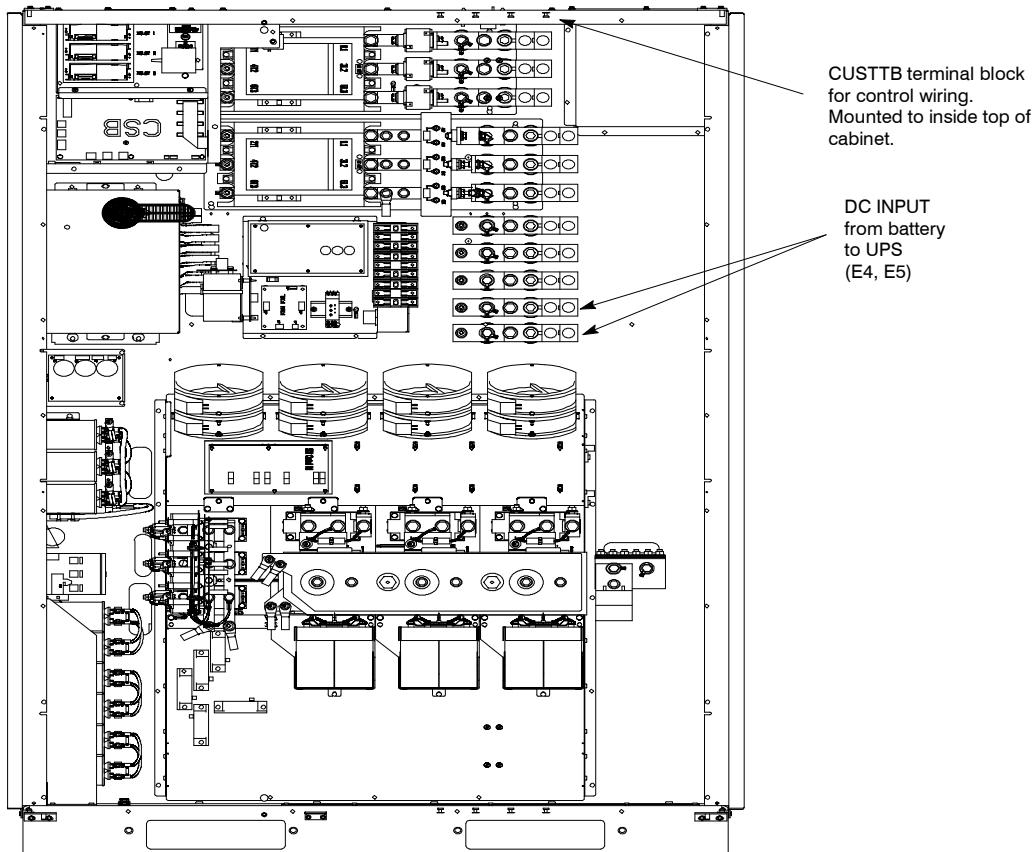

Figure 19. Battery Connections for a Powerware 9350–160

7. Mount the side panels to the sides of the first and last battery cabinets:
 - a. Mount the hanger brackets to the top side of the battery cabinets using M4 screws (refer to Chapter 3, Figure 11 for location).
 - b. Hang the side panel on the hanger brackets and align it with the front and rear of the battery cabinet.
 - c. Secure the side panel at the bottom using M4 hex head screws.
8. Secure all battery cabinets by closing and latching the doors.
9. Secure the UPS by reinstalling safety shields and closing and latching the doors.

WARNING:
Initial closing of the battery cabinet breakers or the external battery disconnect should be performed only in the presence of authorized service personnel.

Completing the Installation Checklist

The final step in installing your battery cabinet is to complete the Installation Checklist. This checklist ensures that you have installed all hardware, cables, and other equipment. Completing all items on the checklist will ensure a smooth installation. Make a copy of the Installation Checklist before filling it out, and retain the original.

After completing your installation, a service representative will be able to verify the operation of your battery cabinet, and commission it to support your critical load. The service representative cannot perform any installation tasks other than verifying that the battery cabinet has been correctly installed. Service personnel may request a copy of the completed Installation Checklist to be sure you have completed all applicable equipment installation requirements.

NOTE:
The Installation Checklist **MUST** be completed prior to starting up the UPS system for the first time.

Installation Checklist for Powerware 9350–160

- All packing materials and restraints have been removed from each cabinet.
- Each cabinet in the battery system is placed in its correct location.
- All battery cabinets are bolted together.
- A ground wire is installed between all cabinets that are bolted together.
- All conduits and cables are properly routed to the battery cabinets.
- A ground conductor is properly installed.
- Battery cables and harness are terminated on the battery terminals E4 and E5 in the UPS cabinet.
- Internal battery cabinet connections have been completed (bus bars, plugs, etc.)
- Air conditioning equipment is installed and operating correctly.
- The area around the installed battery system is clean and dust-free.
(It is recommended that the battery cabinet be installed on a sealed concrete pad or a sealed concrete floor.)
- Adequate working area exists around the battery cabinet and other cabinets.
- Adequate lighting is provided around all battery cabinet equipment.
- A remote battery disconnect control is mounted in its installed location and its wiring is terminated inside the battery cabinet (OPTIONAL).

5

Installing a Remote Battery Disconnect

The remote battery disconnect is crated separately for shipping. It is enclosed in a box and is designed to be wall mounted on a surface that can support the weight and bolt pattern described in this chapter. You can install a remote battery disconnect anywhere between the remote DC supply and the UPS, according to national and local codes. Figure 20 shows the remote battery disconnect enclosure.

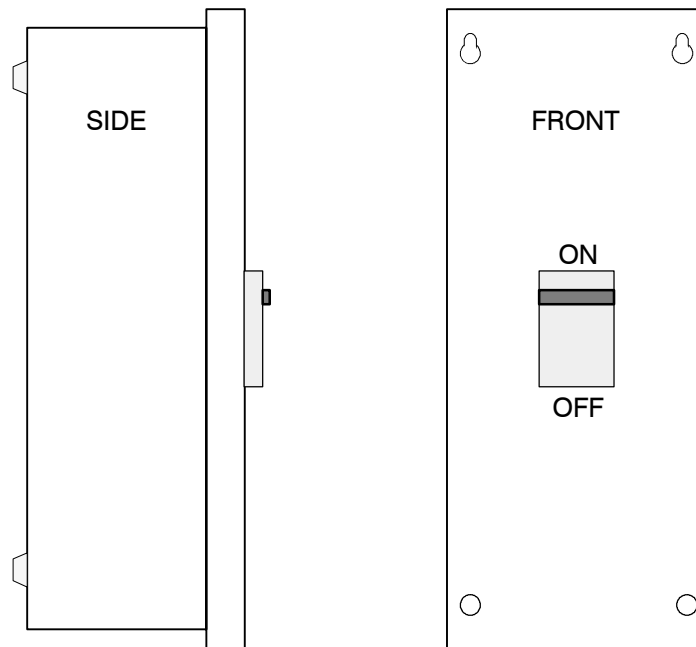

Figure 20. Remote Battery Disconnect Enclosure

The breaker switch on the remote battery disconnect should be set to ON for normal UPS operation when DC power is available at the UPS. When service personnel are performing maintenance on the UPS or battery cabinet, the switch should be OFF.

You should read and understand these general notes before beginning installation:

- The material and labor for external wiring requirements is to be supplied by others.
- Power cables and control wiring must be installed in separate conduit.
- The ground conductor is to be sized per NEC Article 250 and local electrical code requirements.
- The maximum current listed is at the minimum DC operating voltage.
- Nominal voltages listed in this chapter are for a lead-acid battery plant rated per NEC at 2.00 VDC per cell.
- Battery cabinets must be installed in accordance with all applicable codes and regulations, including the National Electrical Code (NEC), Article 480.
- The UPS to battery cable should be sized for a total maximum voltage drop of 1% nominal DC link voltage at maximum current.
- The external wiring specifications are outlined in Table C of Appendix A. Tables A and B in this chapter detail the power cable terminations.
- The remote battery disconnect weighs approximately 11.4 kg (25 lb) and has an ampere interrupting capacity of 10,000 at 500 VDC.
- Tightening Torque: 28.7 – 31.1 N-M (255–275 lb-in.)
Internal Drive Hex Size: 5/16 in.
- The knockout pattern for conduit is shown in Figure 21. If a larger size conduit is required, the contractor may enlarge knockouts at your site during installation.

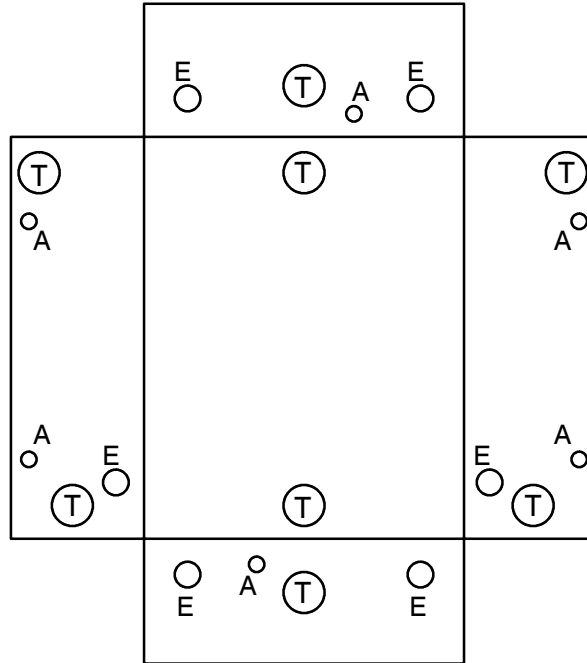

Figure 21. Knockout Pattern for Remote Battery Disconnect

Table A. Remote Battery Disconnect Power Terminations		
<i>Terminal</i>	<i>Size of Pressure Termination</i>	<i>Terminal Function</i>
E4 (+)	1 – #8–3/0	UPS Battery Contactor K2 (+)
E5 (–)	1 – #8–3/0	UPS Battery Contactor K2 (–)
Breaker (+)	1 – #4–300 kcmil	Battery Disconnect (+)
Breaker (–)	1 – #4–300 kcmil	Battery Disconnect (–)
Breaker (jumper)	1 – #4–300 kcmil	Battery Disconnect (jumper)
Battery Cabinet (+)	See Table C (Appendix A)	Stand-alone battery cabinet (+)
Battery Cabinet (–)	See Table C (Appendix A)	Stand-alone battery cabinet (–)

Table B. Battery Cabinet Terminations	
<i>Battery Cabinet</i>	<i>Size of Pressure Termination</i>
Series 685	(1) #2–1/0 kcmil [Breaker (+) & (–)]
Series 1085	(1) 3/0–250 kcmil [Breaker (+) & (–)]

Table C. Remote Battery Disconnect Circuit Breaker Ratings		
<i>UPS Model</i>	<i>Circuit Breaker Rating</i>	<i>DC Voltage</i>
9350-40	125	420
9350-50	125	480
9350-65	175	420
9350-80	200	480
9350-125	350	420
9350-130	350	420
9350-150	350	480
9350-160	350	480
9350-200	600	420
9350-225	600	480
9350-250	800	420
9350-300	800	480
9350-300	900	420
9350-400	1200	420
9350-400	1000	480
9350-500	1200	480

Appendix A – Customer Information

The information in the appendix will help you plan for and install your battery system. The appendix contains these drawings:

164201408–1 Series 685 Battery Cabinet

164201408–2 Series 1085 Battery Cabinet

164201408–3 Remote Interface Connections

164201408–4 Series 685 / 1085 Configurations

NOTE: *Outline diagrams and oneline diagrams for the various UPS models are available in their respective manuals. See this manual for more information.*

164201407 Powerware® 9350 (100 kVA–160 kVA) UPS Installation
and Operation Manual

1. The output of the UPS is a separately derived source. Output neutral is bonded to equipment ground through the main bonding jumper. Refer to NEC Article 250 and local codes for proper grounding practices.
2. Your battery cabinet operating environment must meet the size and weight requirements shown in Table A:

Table A. Equipment Weight and Point Loading (on casters) (4 leveling feet are provided)		
<i>Component</i>	<i>Weight Kg (lb)</i>	<i>Point Loading Kg (lb)</i>
Series 685-J14	869 (1915)	4 at 217 (479)
Series 685-J17	1111 (2450)	4 at 278 (613)
Series 1085-J27	1429 (3150)	8 at 179 (394)
Series 1085-J31	1588 (3500)	8 at 199 (438)
Series 1085-J37	1708 (3765)	8 at 214 (471)
Series 1085-J47	2178 (4800)	8 at 272 (600)

3. The basic environmental requirements for operation of the battery system are:

Ambient Temperature Range: 10–40°C (50–104°F)

Recommended Operating Range: 20–25°C (68–77°F)

Maximum Relative Humidity: 95% noncondensing

4. Use Class 1 wiring methods (as defined by the NEC) for control wiring. Install the control wiring in separate conduit from the power wiring. The wire should be rated at 24 volts, 1 amp minimum.
5. Battery voltage is computed at 2 volts per cell as defined by Article 480 of the NEC. Rated battery current is computed at 1.8 volts per cell.
6. The battery wiring used between the battery and the UPS should not allow a voltage drop of more than 1% of nominal DC voltage at rated battery current.
7. A battery disconnect switch is recommended, and may be required by NEC or local codes when batteries are separately located. The battery disconnect switch may be supplied as an accessory, and should be installed between the battery and the UPS.
8. If the conductors used for DC input from the battery cabinet(s) to the UPS are those provided by the UPS manufacturer, and the UPS and battery cabinet are manufactured by the same supplier, then it is acceptable if they do not meet the noted minimum conductor sizes.

Table B. External Ground Wire Requirements for Battery Cabinets							
UPS Model	Battery Series	Battery Type	# of Cabinets	Integral or Separate Battery	Wire Size Battery	Tool Size Battery Cabinet	Torque N-M (lb-in)
all	685 or 1085	all	all	all	1/0	7/16" slot	5.6 (50)

Table C. External Wiring Requirements (UPS-to-Battery or Remote Disconnect-to-Battery)

NOTE: All specified wire sizes are 90°C rated copper minimum						Battery Cabinet		UPS Cabinet	
UPS Series/ Model	Battery Cabinet Series	Battery Type*	# of Cabinets	Integral or Separate	Wire Size UPS to Battery	Tool Size	Torque N-M (lb-in)	Tool Size	Torque N-M (lb-in)
50/30	685	B14, B17, H20	1 or 2	Integral	Supplied	3/8" hex	42.4 (375)	1/4" hex	22.6 (200)
50/30	685	B14, B17, H20	1 or 2	Separate	2/0	3/8" hex	42.4 (375)	1/4" hex	22.6 (200)
50/30	1085R	B10	1, 2, 3, or 4	Integral	Supplied	3/8" hex	42.4 (375)	3/8" hex	42.4 (375)
50/30	1085R	B10	1, 2, 3, or 4	Separate	3/0	3/8" hex	42.4 (375)	3/8" hex	42.4 (375)
50/30	1085	B27, B31, B37, B47, H30, H40, H50	1, 2, 3, or 4	Integral	Supplied	3/8" hex	42.4 (375)	1/4" hex	22.6 (200)
50/30	1085	B27, B31, B37, B47, H30, H40, H50	1, 2, 3, or 4	Separate	2/0	3/8" hex	42.4 (375)	1/4" hex	22.6 (200)
50/40	685	B14, B17, H20	1 or 2	Integral	Supplied	3/8" hex	42.4 (375)	1/4" hex	22.6 (200)
50/40	685	B14, B17, H20	1 or 2	Separate	2/0	3/8" hex	42.4 (375)	1/4" hex	22.6 (200)
50/40	1085R	B10	1, 2, 3, or 4	Integral	Supplied	3/8" hex	42.4 (375)	3/8" hex	42.4 (375)
50/40	1085R	B10	1, 2, 3, or 4	Separate	3/0	3/8" hex	42.4 (375)	3/8" hex	42.4 (375)
50/40	1085	B27, B31, B37, B47, H30, H40, H50	1, 2, 3, or 4	Integral	Supplied	3/8" hex	42.4 (375)	1/4" hex	22.6 (200)
50/40	1085	B27, B31, B37, B47, H30, H40, H50	1, 2, 3, or 4	Separate	2/0	3/8" hex	42.4 (375)	1/4" hex	22.6 (200)
50/50	685	B14, B17, H20	1 or 2	Integral	Supplied	3/8" hex	42.4 (375)	1/4" hex	22.6 (200)
50/50	685	B14, B17, H20	1 or 2	Separate	2/0	3/8" hex	42.4 (375)	1/4" hex	22.6 (200)
50/50	1085R	B10	1, 2, 3, or 4	Integral	Supplied	3/8" hex	42.4 (375)	3/8" hex	42.4 (375)
50/50	1085R	B10	1, 2, 3, or 4	Separate	3/0	3/8" hex	42.4 (375)	3/8" hex	42.4 (375)
50/50	1085	B27, B31, B37, B47, H30, H40, H50	1, 2, 3, or 4	Integral	Supplied	3/8" hex	42.4 (375)	1/4" hex	22.6 (200)
50/50	1085	B27, B31, B37, B47, H30, H40, H50	1, 2, 3, or 4	Separate	2/0	3/8" hex	42.4 (375)	1/4" hex	22.6 (200)
80/50	685	B14, B17, H20	1 or 2	Integral	Supplied	3/8" hex	42.4 (375)	1/4" hex	22.6 (200)
80/50	685	B14, B17, H20	1 or 2	Separate	2/0	3/8" hex	42.4 (375)	1/4" hex	22.6 (200)
80/50	1085R	B10	1, 2, 3, or 4	Integral	Supplied	3/8" hex	42.4 (375)	3/8" hex	42.4 (375)

Table C. External Wiring Requirements (UPS-to-Battery or Remote Disconnect-to-Battery)									
NOTE: All specified wire sizes are 90°C rated copper minimum						Battery Cabinet		UPS Cabinet	
UPS Series/ Model	Battery Cabinet Series	Battery Type*	# of Cabinets	Integral or Separate	Wire Size UPS to Battery	Tool Size	Torque N-M (lb-in)	Tool Size	Torque N-M (lb-in)
80/50	1085R	B10	1, 2, 3, or 4	Separate	3/0	3/8" hex	42.4 (375)	3/8" hex	42.4 (375)
80/50	1085	B27, B31, B37, B47, H30, H40, H50	1, 2, 3, or 4	Integral	Supplied	3/8" hex	42.4 (375)	1/4" hex	22.6 (200)
80/50	1085	B27, B31, B37, B47, H30, H40, H50	1, 2, 3, or 4	Separate	2/0	3/8" hex	42.4 (375)	1/4" hex	22.6 (200)
80/60	685	H20	1	Integral	Supplied	3/8" hex	42.4 (375)	1/4" hex	22.6 (200)
		B14, B17	2						
80/60	685	H20	1	Separate	2/0	3/8" hex	42.4 (375)	1/4" hex	22.6 (2)
		B14, B17	2						
80/60	1085R	B10	1	Integral	Supplied	3/8" hex	42.4 (375)	3/8" hex	42.4 (375)
80/60	1085R	B10	1	Separate	3/0	3/8" hex	42.4 (375)	3/8" hex	42.4 (375)
80/60	1085	B27, B31, B37, B47, H30, H40, H50	1, 2, 3, or 4	Integral	Supplied	3/8" hex	42.4 (375)	1/4" hex	22.6 (200)
80/60	1085	B27, B31, B37, B47, H30, H40, H50	1, 2, 3, or 4	Separate	2/0	3/8" hex	42.4 (375)	1/4" hex	22.6 (200)
80/80	685	H20	1	Integral	Supplied	3/8" hex	42.4 (375)	1/4" hex	22.6 (200)
		B14, B17, H20	2						
80/80	685	H20	1	Separate	2/0	3/8" hex	42.4 (375)	1/4" hex	22.6 (200)
		B14, B17, H20	2						
80/80	1085	B27, B31, B37, B47, H30, H40, H50	1, 2, 3, or 4	Integral	Supplied	3/8" hex	42.4 (375)	1/4" hex	22.6 (200)
80/80	1085	B27, B31, B37, B47, H30, H40, H50	1, 2, 3, or 4	Separate	2/0	3/8" hex	42.4 (375)	1/4" hex	22.6 (200)
160/100	685	B14, B17, H20	2	Integral	Supplied	3/8" hex	42.4 (375)	3/8" hex	42.4 (375)
160/100	685	B14, B17, H20	2	Separate	3/0	3/8" hex	42.4 (375)	3/8" hex	42.4 (375)
160/100	1085	B27, B31, B37, B47, H30, H40, H50	1, 2, 3, or 4	Integral	Supplied	3/8" hex	42.4 (375)	3/8" hex	42.4 (375)
160/100	1085	B27, B31, B37, B47, H30, H40, H50	1, 2, 3, or 4	Separate	3/0	3/8" hex	42.4 (375)	3/8" hex	42.4 (375)

Table C. External Wiring Requirements (UPS-to-Battery or Remote Disconnect-to-Battery)									
NOTE: All specified wire sizes are 90°C rated copper minimum						Battery Cabinet		UPS Cabinet	
UPS Series/ Model	Battery Cabinet Series	Battery Type*	# of Cabinets	Integral or Separate	Wire Size UPS to Battery	Tool Size	Torque N-M (lb-in)	Tool Size	Torque N-M (lb-in)
160/125	685	H20	2	Integral	Supplied	3/8" hex	42.4 (375)	3/8" hex	42.4 (375)
160/125	685	H20	2	Separate	300 kcmil	3/8" hex	42.4 (375)	3/8" hex	42.4 (375)
160/125	1085	B27, B31, B37, B47, H30, H40, H50	2, 3, or 4	Integral	Supplied	3/8" hex	42.4 (375)	3/8" hex	42.4 (375)
160/125	1085	B27, B31, B37, B47, H30, H40, H50	2, 3, or 4	Separate	300 kcmil	3/8" hex	42.4 (375)	3/8" hex	42.4 (375)
160/150	685	H20	2	Integral	Supplied	3/8" hex	42.4 (375)	3/8" hex	42.4 (375)
160/150	685	H20	2	Separate	300 kcmil	3/8" hex	42.4 (375)	3/8" hex	42.4 (375)
160/150	1085	B27, B31, B37, B47, H30, H40, H50	2, 3, or 4	Integral	Supplied	3/8" hex	42.4 (375)	3/8" hex	42.4 (375)
160/150	1085	B27, B31, B37, B47, H30, H40, H50	2, 3, or 4	Separate	300 kcmil	3/8" hex	42.4 (375)	3/8" hex	42.4 (375)
160/160	685	H20	2	Integral	Supplied	3/8" hex	42.4 (375)	3/8" hex	42.4 (375)
160/160	685	H20	2	Separate	300 kcmil	3/8" hex	42.4 (375)	3/8" hex	42.4 (375)
160/160	1085	B27, B31, B37, B47, H30, H40, H50	1, 2, 3, or 4	Integral	Supplied	3/8" hex	42.4 (375)	3/8" hex	42.4 (375)
160/160	1085	B27, B31, B37, B47, H30, H40, H50	1, 2, 3, or 4	Separate	350 kcmil	3/8" hex	42.4 (375)	3/8" hex	42.4 (375)

*** BATTERY TYPE DESIGNATIONS: B = C&D, H = HAWKER**

NOTE: The term "Separate" refers to battery cabinets that are not physically attached to the UPS, are wired with external contractor supplied wiring, and use a single overcurrent protection and disconnect device located near the batteries.

The term "Integral" refers to battery cabinets that are physically attached to the UPS and the wiring between them is internal. The power wiring is supplied with the system, and they use the UPS battery switch as the battery isolation device.

The wire size rating for products up to and including the 160/160 are for the total battery supply. Since these UPS units can only land one wire per DC connection point, a common DC collector including an isolation device and overcurrent protection should be used. Refer to applicable national or local code requirements for your installation.

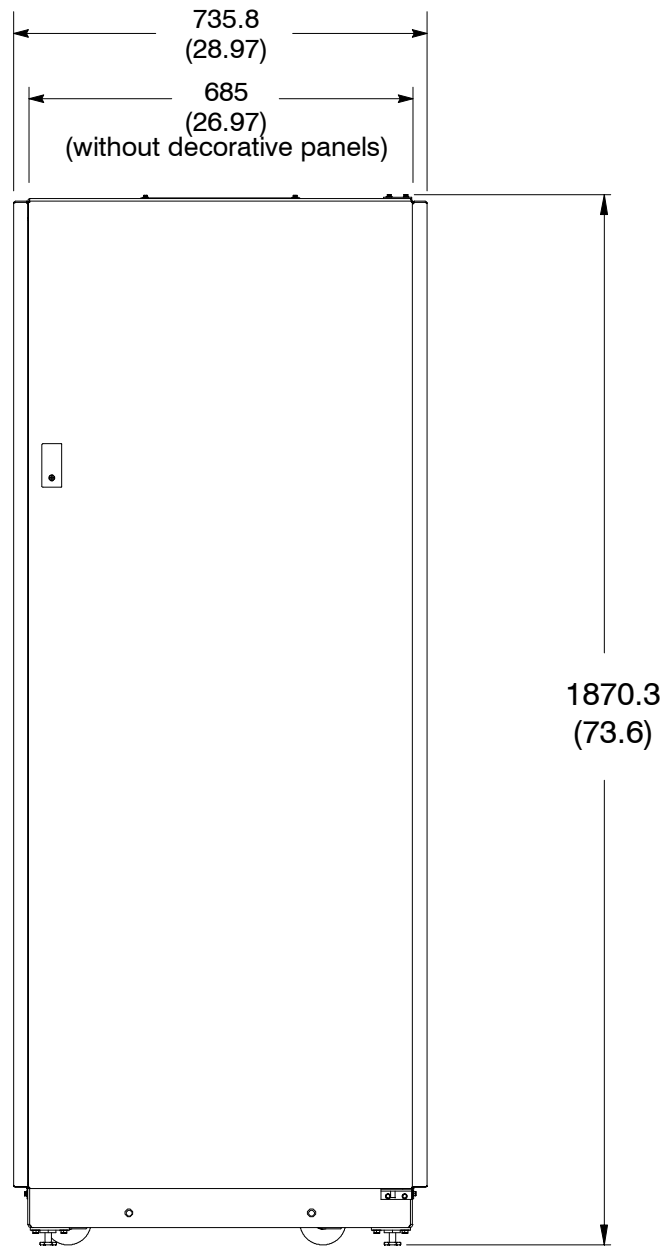

Series 685 Battery Cabinet

Dimensions are in millimeters (inches)

DESCRIPTION: **Series 685 Battery Cabinet (elevation)**

DRAWING NO: **164201408-1**

SHEET: 1 of 2

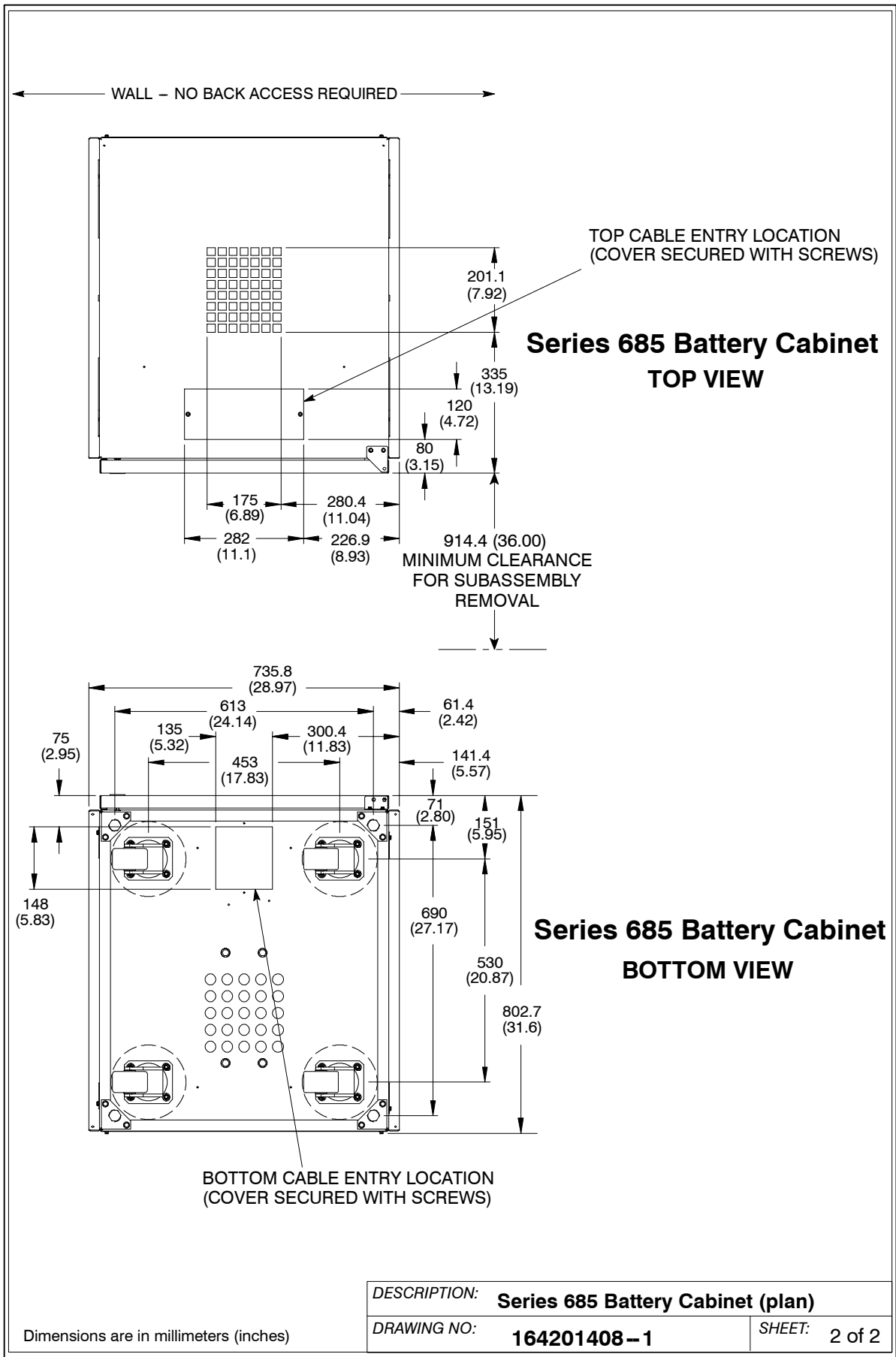

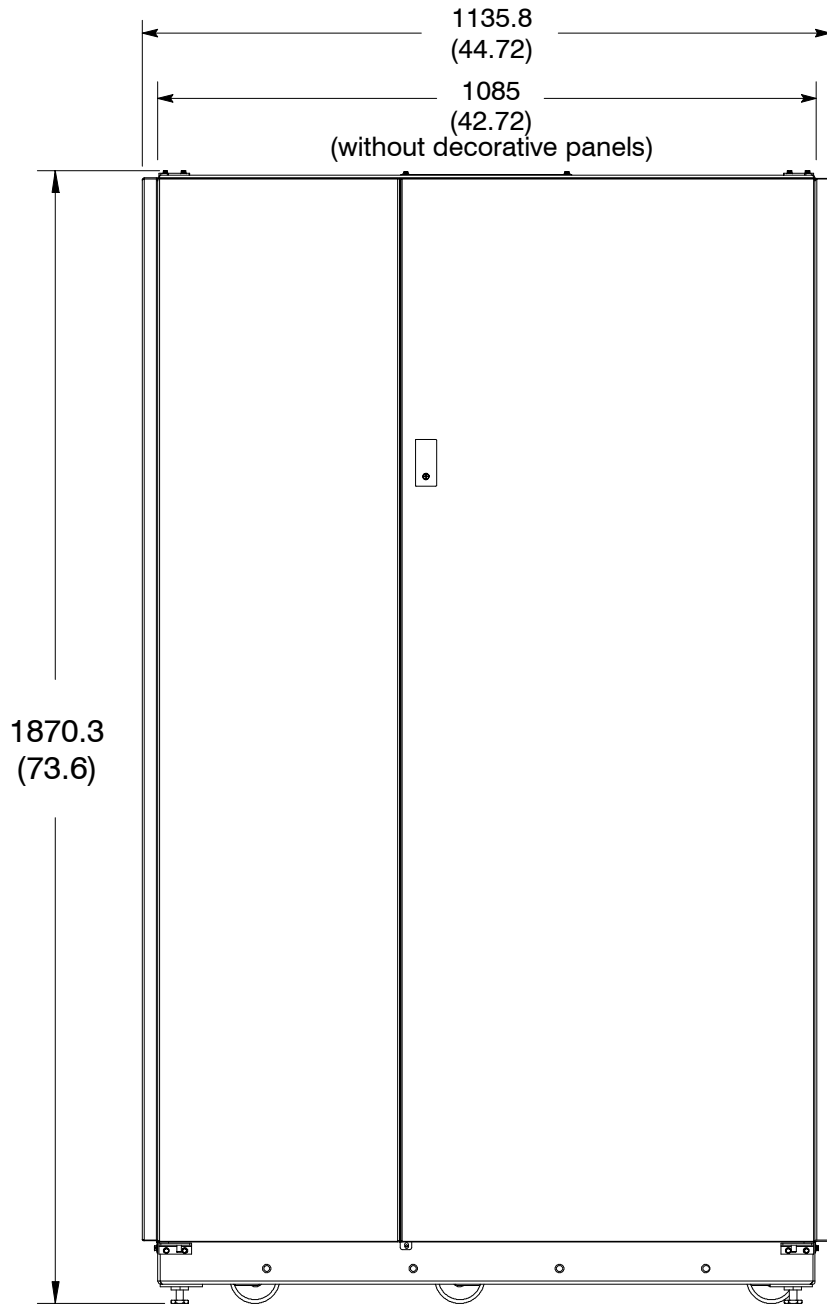

Series 1085 Battery Cabinet

Dimensions are in millimeters (inches)

DESCRIPTION:	Series 1085 Battery Cabinet (elevation)	
DRAWING NO:	164201408-2	SHEET: 1 of 2

**Series 1085 Battery Cabinet
(TOP VIEW)**

TOP CABLE ENTRY LOCATION
(COVER SECURED WITH SCREWS)

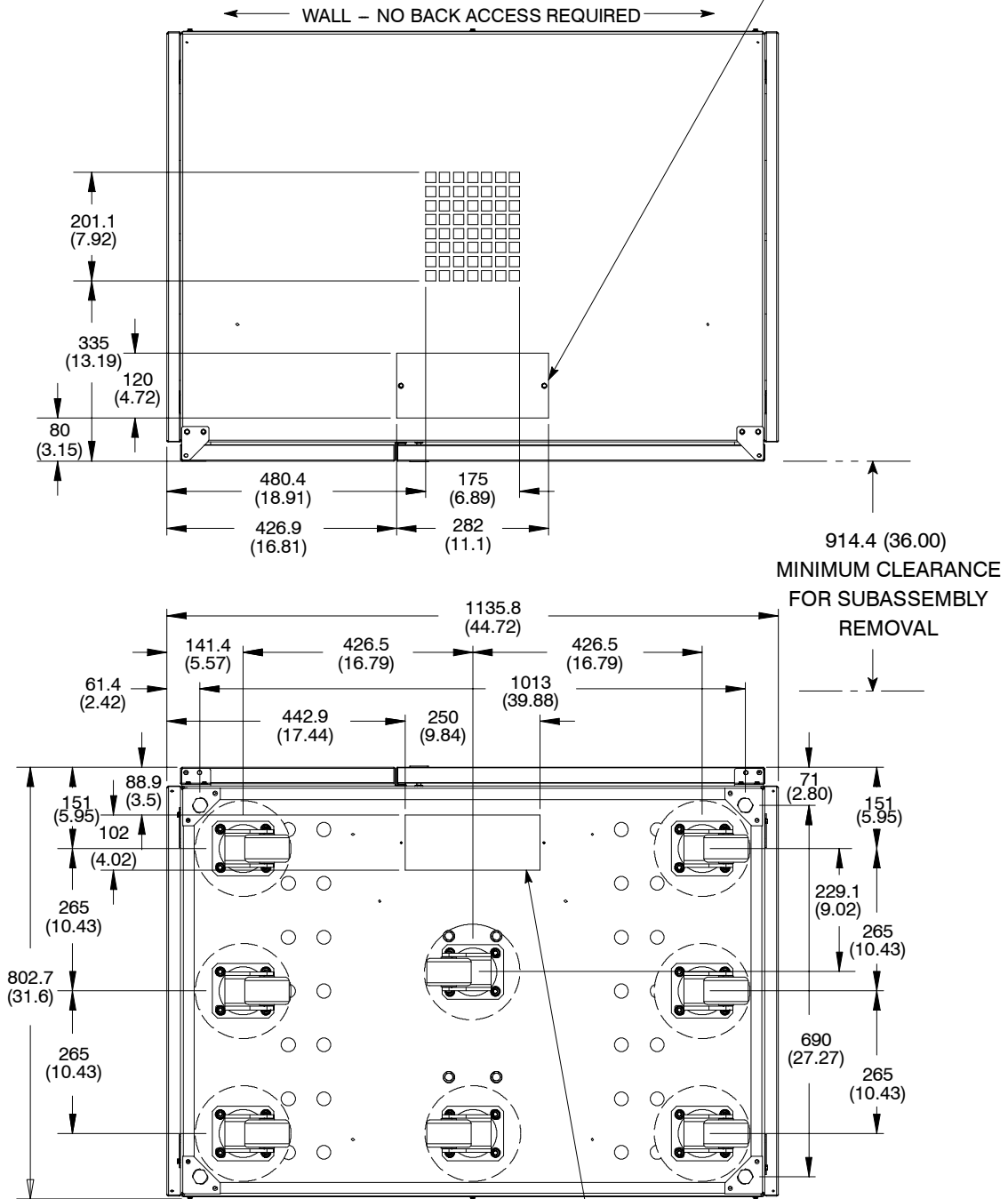

**Series 1085 Battery Cabinet
(BOTTOM VIEW)**

BOTTOM CABLE ENTRY LOCATION
(COVER SECURED WITH SCREWS)

DESCRIPTION:	Series 1085 Battery Cabinet (plan)	
DRAWING NO:	164201408-2	SHEET: 2 of 2

Dimensions are in millimeters (inches)

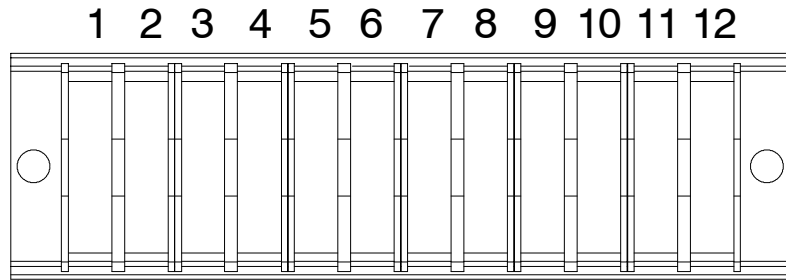

TB1

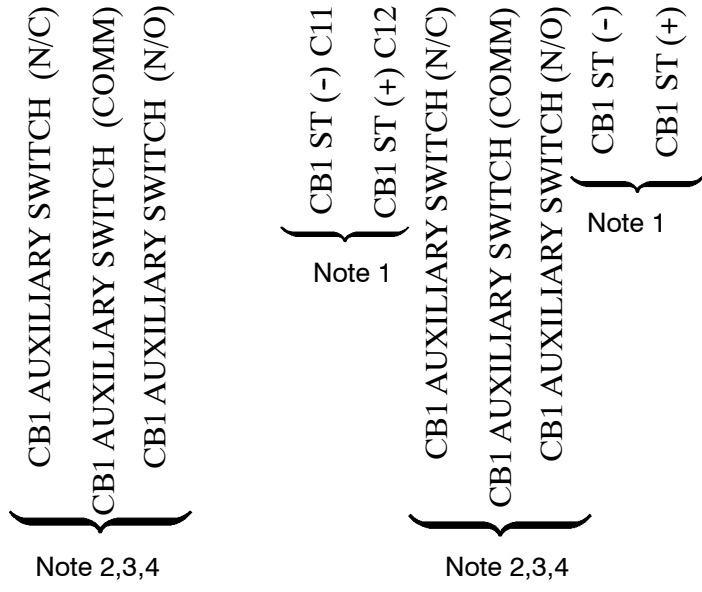

Notes:

1. Shunt trip requires 24V (150 VA instantaneous) to activate (supplied by user).
2. Auxiliary switches are rated as follows:
 - 240 VAC @ 15A
 - 125 VDC @ 0.3A
 - 250 VDC @ 0.15A
3. Wiring shall be suitable for Class 1, 600V wiring methods.
All wiring shall be #10-22 AWG, 75 deg. C minimum.
4. Torque screw terminals to 20 in.-lb.

<i>DESCRIPTION:</i> Remote Interface Connections	
<i>DRAWING NO:</i> 164201408-3	<i>SHEET:</i> 1 of 1

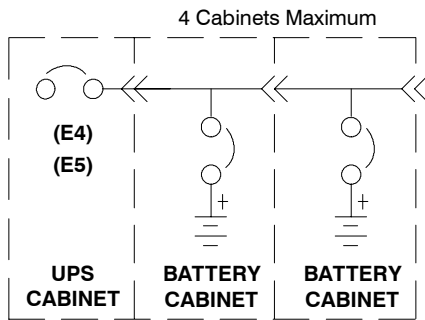

Powerware 9350 30 through 160
 Battery Cabinets integral to UPS
 and connected using Manufacturer supplied wiring

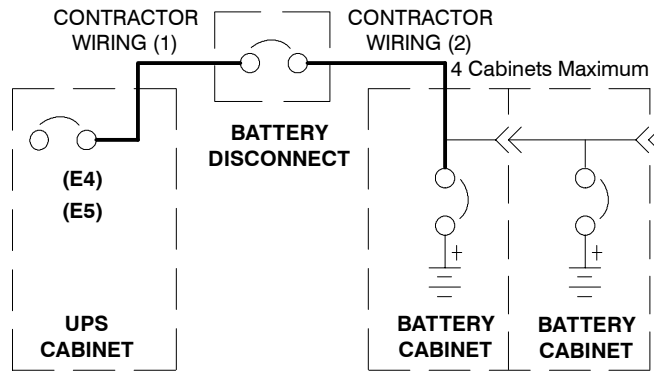

Powerware 9350 30 through 160
 Battery Cabinets located separately
 from the UPS

NOTE: The term “Separate” refers to battery cabinets that are not physically attached to the UPS, are wired with external contractor supplied wiring, and use a single overcurrent protection and disconnect device located near the batteries.

The term “Integral” refers to battery cabinets that are physically attached to the UPS and the wiring between them is internal. The power wiring is supplied with the system, and they use the UPS battery switch as the battery isolation device.

The wire size rating for products up to and including the 160/160 are for the total battery supply. Since these UPS units can only land one wire per DC connection point, a common DC collector including an isolation device and overcurrent protection should be used. Refer to applicable national or local code requirements for your installation.

Contractor Wiring (1): Refer to UPS manual to size wiring

Contractor Wiring (2): See
 Table C of Appendix A to size
 Contractor Supplied wiring

DESCRIPTION:	Series 685 / 1085 Configurations	
DRAWING NO:	164201408-4	SHEET: 1 of 1

This Page Intentionally Left Blank.