



Dell™ Inspiron™ 518/519 Service Manual

- [Technical Overview](#)
- [Before You Begin](#)
- [Removing the Computer Cover](#)
- [Replacing the Front Panel](#)
- [Replacing Memory Module\(s\)](#)
- [Replacing a PCI/PCI Express Card](#)
- [Replacing Drives](#)
- [Replacing Fans](#)
- [Replacing the Front I/O Panel](#)
- [Replacing the Processor](#)
- [Replacing the System Board](#)
- [Replacing the Power Supply](#)
- [Replacing the Battery](#)
- [Replacing the Computer Cover](#)
- [System Setup](#)

Model: DCMF

Notes, Notices, and Cautions

-  **NOTE:** A NOTE indicates important information that helps you make better use of your computer.
 -  **NOTICE:** A NOTICE indicates either potential damage to hardware or loss of data and tells you how to avoid the problem.
 -  **CAUTION:** A CAUTION indicates a potential for property damage, personal injury, or death.
-

Information in this document is subject to change without notice.
© 2008 Dell Inc. All rights reserved.

Reproduction in any manner whatsoever without the written permission of Dell Inc. is strictly forbidden.

Trademarks used in this text: *Dell*, the *DELL* logo, and *Inspiron* are trademarks of Dell Inc.; *AMD* is a trademark of Advanced Micro Devices Inc.; *Microsoft* and *Windows* are either trademarks or registered trademarks of Microsoft Corporation in the United States and/or other countries.

Other trademarks and trade names may be used in this document to refer to either the entities claiming the marks and names or their products. Dell Inc. disclaims any proprietary interest in trademarks and trade names other than its own.

May 2008 Rev. A00

Before You Begin

Dell™ Inspiron™ 518/519 Service Manual

- [Technical Specifications](#)
- [Recommended Tools](#)
- [Turning Off Your Computer](#)
- [Safety Instructions](#)

This chapter provides procedures for removing and installing the components in your computer. Unless otherwise noted, each procedure assumes that the following conditions exist:

- 1 You have performed the steps in [Turning Off Your Computer](#) and [Safety Instructions](#).
- 1 You have read the safety information that shipped with your computer.
- 1 A component can be replaced or—if purchased separately—installed by performing the removal procedure in reverse order.

Technical Specifications

For information on technical specifications of your computer, see the *Quick Reference Guide* that shipped with your computer or see the Dell Support website at support.dell.com.

Recommended Tools

The procedures in this document may require the use of a small Phillips screwdriver size #2.

Turning Off Your Computer

➡ **NOTICE:** To avoid losing data, save and close all open files and exit all open programs before you turn off your computer.

1. Shut down the operating system.
2. Ensure that the computer and all attached devices are turned off. If your computer and attached devices did not automatically turn off when you shut down your operating system, press and hold the power button for about 4 seconds to turn them off.

Safety Instructions

Use the following safety guidelines to help protect your computer from potential damage and to help to ensure your own personal safety.

⚠ **CAUTION:** Before working inside your computer, read the safety information that shipped with your computer. For additional safety best practices information, see the [Regulatory Compliance Homepage](http://www.dell.com/regulatory_compliance) at www.dell.com/regulatory_compliance.

➡ **NOTICE:** Only a certified service technician should perform repairs on your computer. Damage due to servicing that is not authorized by Dell™ is not covered by your warranty.

➡ **NOTICE:** When you disconnect a cable, pull on its connector or on its pull-tab, not on the cable itself. Some cables have connectors with locking tabs: if you are disconnecting this type of cable, press in on the locking tabs before you disconnect the cable. As you pull connectors apart, keep them evenly aligned to avoid bending any connector pins. Also, before you connect a cable, ensure that both connectors are correctly oriented and aligned.

➡ **NOTICE:** To avoid damaging the computer, perform the following steps before you begin working inside the computer.

-
1. Ensure that the work surface is flat and clean to prevent the computer cover from being scratched.
 2. Turn off your computer (see [Turning Off Your Computer](#)).

➡ **NOTICE:** To disconnect a network cable, first unplug the cable from your computer and then unplug the cable from the network device.

3. Disconnect all telephone or network cables from the computer.
4. Disconnect your computer and all attached devices from their electrical outlets.

5. Press and hold the power button while the system is unplugged to ground the system board.

 **NOTICE:** Before touching anything inside your computer, ground yourself by touching an unpainted metal surface, such as the metal at the back of the computer. While you work, periodically touch an unpainted metal surface to dissipate static electricity, which could harm internal components.

[Back to Contents Page](#)

Replacing a PCI/PCI Express Card

Dell™ Inspiron™ 518/519 Service Manual

- [Removing a PCI/PCI Express Card](#)
- [Installing a PCI/PCI Express Card](#)
- [Replacing the Card Retention Bracket](#)
- [Configuring Your Computer After Removing or Installing a PCI/PCI Express Card](#)

⚠ CAUTION: Before working inside your computer, read the safety information that shipped with your computer. For additional safety best practices information, see the Regulatory Compliance Homepage at www.dell.com/regulatory_compliance.

Removing a PCI/PCI Express Card

1. Follow the procedures in [Before You Begin](#).
2. Uninstall the card's driver and software from the operating system. For more information, see the *Quick Reference Guide*.
3. Remove the computer cover. See [Removing the Computer Cover](#).
4. Remove the screw holding the card retention bracket.

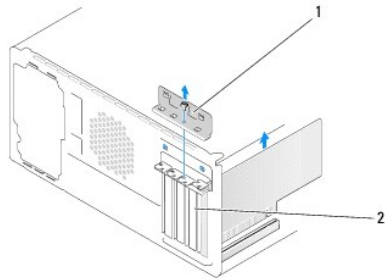

1	card retention bracket	2	filler bracket
---	------------------------	---	----------------

5. Lift the card retention bracket and set it aside in a secure place.
 6. If necessary, disconnect any cables connected to the card.
 - 1 For a PCI card, grasp the card by its top corners, and ease it out of its connector.
 - 1 For a PCI Express card, pull the securing tab, grasp the card by its top corners, and then ease it out of its connector.
 7. If you are replacing an existing card, go to [step 6](#) of [Installing a PCI/PCI Express Card](#).
 8. Install a filler bracket in the empty card-slot opening.
 - ➡ **NOTICE:** Installing filler brackets over empty card-slot openings is necessary to maintain FCC certification of the computer. The brackets also keep dust and dirt out of your computer.
 9. Replace the card retention bracket. See [Replacing the Card Retention Bracket](#).
 10. Replace the computer cover, reconnect the computer and devices to electrical outlets, and then turn them on.
 11. To complete the removal procedure, see [Configuring Your Computer After Removing or Installing a PCI/PCI Express Card](#).
-

Installing a PCI/PCI Express Card

1. Follow the procedures in [Before You Begin](#).
2. Remove the computer cover. See [Removing the Computer Cover](#).

3. Remove the screw holding the card retention bracket.
4. Lift the card retention bracket and set it aside in a secure place.
5. Remove the filler bracket to create a card-slot opening.
6. Prepare the card for installation.

See the documentation that came with the card for information on configuring the card, making internal connections, or otherwise customizing it for your computer.

7. Align the card with the connector.

NOTE: If you are installing a PCI Express card into the x16 connector, ensure that the securing slot is aligned with the securing tab.

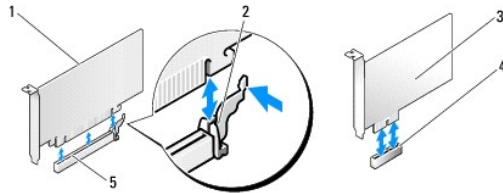

1	PCI Express x16 card	2	securing tab
3	PCI Express x1 card	4	PCI Express x1 card slot
5	PCI Express x16 card slot		

8. Place the card in the connector and press down firmly. Ensure that the card is fully seated in the slot.

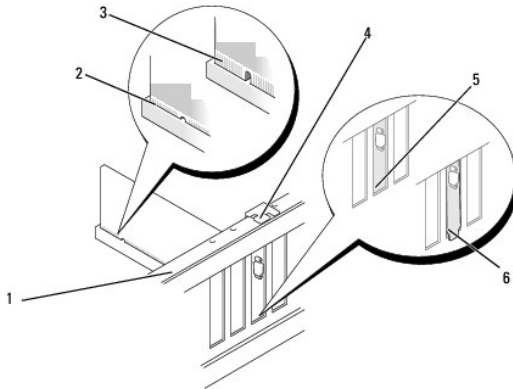

1	alignment bar	2	fully-seated card
3	not fully-seated card	4	alignment guide
5	bracket within slot	6	bracket caught outside of slot

9. Replace the card retention bracket. See [Replacing the Card Retention Bracket](#).

NOTICE: Do not route card cables over or behind the cards. Cables routed over the cards can prevent the computer cover from closing properly or cause damage to the equipment.

10. Connect any cables that should be attached to the card.

See the documentation for the card for information about the card's cable connections.

11. Replace the computer cover, reconnect the computer and devices to electrical outlets, and then turn them on.

12. To complete the installation, see [Configuring Your Computer After Removing or Installing a PCI/PCI Express Card](#).

Replacing the Card Retention Bracket

Replace the card retention bracket ensuring that:

- 1 The guide clamp is aligned with the guide notch.
- 1 The tops of all cards and filler brackets are flush with the alignment bar.
- 1 The notch in the top of the card or filler bracket fits around the alignment guide.

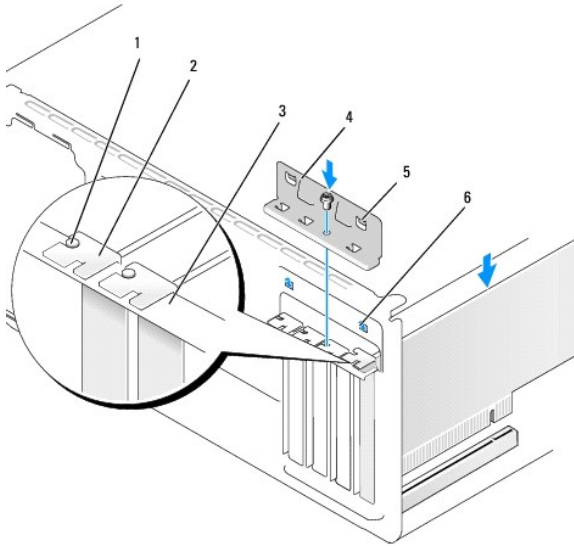

1	alignment guide	2	filler bracket
3	alignment bar	4	card retention bracket
5	guide clamp (2)	6	guide notch (2)

Configuring Your Computer After Removing or Installing a PCI /PCI Express Card

NOTE: For information on location of connectors, see the *Quick Reference Guide*. For information on installing drivers and software for your card, see the documentation that shipped with the card.

	Installed	Removed
Sound Card	<ol style="list-style-type: none"> 1. Enter system setup (see System Setup). 2. Go to Integrated Peripherals and select Onboard Audio Controller, and then change the setting to Disabled. 3. Connect the external audio devices to the sound card's connectors. 	<ol style="list-style-type: none"> 1. Enter system setup (see System Setup). 2. Go to Integrated Peripherals and select Onboard Audio Controller, and then change the setting to Enabled. 3. Connect the external audio devices to the computer's back panel connectors.
Network Card	<ol style="list-style-type: none"> 1. Enter system setup (see System Setup). 2. Go to Integrated Peripherals and select Onboard LAN Controller, and then change the setting to Disabled. 3. Connect the network cable to the network card's connector. 	<ol style="list-style-type: none"> 1. Enter system setup (see System Setup). 2. Go to Integrated Peripherals and select Onboard LAN Controller, and then change the setting to Enabled. 3. Connect the network cable to the integrated network connector.

[Back to Contents Page](#)

Replacing the Battery

Dell™ Inspiron™ 518/519 Service Manual

⚠ CAUTION: Before working inside your computer, read the safety information that shipped with your computer. For additional safety best practices information, see the Regulatory Compliance Homepage at www.dell.com/regulatory_compliance.

⚠ CAUTION: A new battery can explode if it is incorrectly installed. Replace the battery only with the same or equivalent type recommended by the manufacturer. Discard used batteries according to the manufacturer's instructions.

1. Record all the screens in system setup (see [System Setup](#)) so that you can restore the correct settings in [step 10](#).
2. Follow the procedures in [Before You Begin](#).
3. Remove the computer cover (see [Removing the Computer Cover](#)).
4. Locate the battery socket (see [System Board Components](#)).

🔧 NOTICE: If you pry the battery out of its socket with a blunt object, be careful not to touch the system board with the object. Ensure that the object is inserted between the battery and the socket before you attempt to pry out the battery. Otherwise, you may damage the system board by prying off the socket or by breaking circuit traces on the system board.

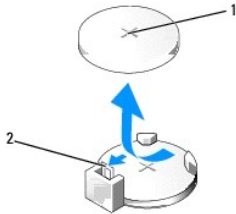

1	battery (positive side)	2	battery release lever
---	-------------------------	---	-----------------------

5. Carefully press the battery release lever away from the battery and the battery will pop out.
6. Remove the battery from the system and properly dispose of the battery.
7. Insert the new battery into the socket with the side labeled "+" facing up, then snap the battery into place.

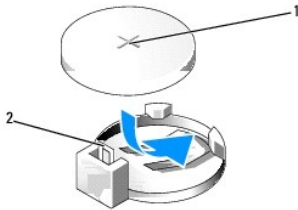

1	battery (positive side)	2	battery release lever
---	-------------------------	---	-----------------------

8. Replace the computer cover (see [Replacing the Computer Cover](#)).
 9. Connect your computer and devices to electrical outlets, and then turn them on.
 10. Enter system setup (see [System Setup](#)) and restore the settings you recorded in [step 1](#).
-

Replacing the Computer Cover

Dell™ Inspiron™ 518/519 Service Manual

CAUTION: Before working inside your computer, read the safety information that shipped with your computer. For additional safety best practices information, see the Regulatory Compliance Homepage at www.dell.com/regulatory_compliance.

CAUTION: Do not operate your equipment with any cover(s) (including computer covers, front panel, filler brackets, front-panel inserts, etc.) removed.

1. Ensure that all cables are connected, and fold cables out of the way.
2. Ensure that no tools or extra parts are left inside the computer.
3. Align the tabs at the bottom of the computer cover with the slots located along the edge of the computer.
4. Press the computer cover down and slide it towards the front of the computer until you feel the computer cover is securely installed.
5. Ensure that the cover is seated correctly.
6. Replace and tighten the two screws that secure the computer cover, using a screwdriver.

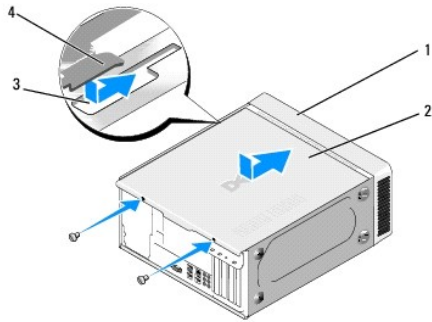

1	front of the computer	2	computer cover
3	slot	4	computer cover tab



7. Turn the computer to the upright position.

NOTICE: Ensure that none of the system air-vents are blocked. Blocking them would cause serious thermal problems.

8. Connect your computer and devices to electrical outlets, and turn them on.
-

Removing the Computer Cover

Dell™ Inspiron™ 518/519 Service Manual

-  **CAUTION:** Before working inside your computer, read the safety information that shipped with your computer. For additional safety best practices information, see the Regulatory Compliance Homepage at www.dell.com/regulatory_compliance.
 -  **CAUTION:** To guard against likelihood of electric shock, laceration by moving fan blades or other unexpected injuries, always unplug your computer from the electrical outlet before removing the cover.
 -  **NOTICE:** Ensure that sufficient space exists to support the system with the cover removed—at least 30 cm (1 ft.) of desktop space.
-

1. Follow the procedures in [Before You Begin](#).
2. Lay your computer on its side with the computer cover facing up.
3. Open the padlock, if applicable.
4. Loosen the two thumbscrews.

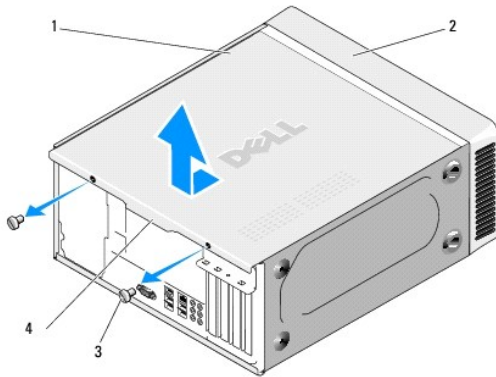

1	computer cover	2	front of computer
3	thumbscrew (2)	4	cover grip

5. Pull the cover grip towards the back of the computer to release the cover.
6. Set the cover aside in a secure location.

To replace the computer cover, see [Replacing the Computer Cover](#).

Replacing the Processor

Dell™ Inspiron™ 518/519 Service Manual

- [Removing the Processor](#)
- [Installing the Processor](#)

CAUTION: Before working inside your computer, read the safety information that shipped with your computer. For additional safety best practices information, see the [Regulatory Compliance Homepage](http://www.dell.com/regulatory_compliance) at www.dell.com/regulatory_compliance.

NOTICE: Do not perform the following steps unless you are familiar with hardware removal and replacement. Performing these steps incorrectly could damage your system board. For technical service, see the *Quick Reference Guide*.

Removing the Processor

1. Follow the procedures in [Before You Begin](#).
2. Remove the computer cover (see [Removing the Computer Cover](#)).

CAUTION: Despite having a plastic shield, the heat sink assembly may be very hot during normal operation. Be sure that it has had sufficient time to cool before you touch it.

3. Disconnect the power cables from the ATX_POWER and ATX_CPU connectors (see [System Board Components](#)) on the system board.
4. Remove the processor fan and heat sink assembly from the computer (see [Replacing the Processor Fan and Heat Sink Assembly](#)).

NOTE: Unless a new heat sink is required for the new processor, reuse the original heat sink assembly when you replace the processor.

5. Press and push the release lever down and out to release it from the tab that secures it.
6. Open the processor cover, if applicable.

Dell™ Inspiron™ 518

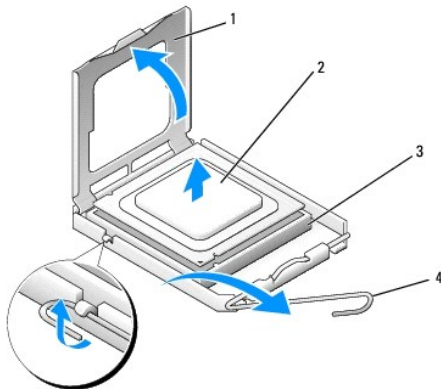

1	processor cover	2	processor
3	socket	4	release lever

Dell Inspiron 519

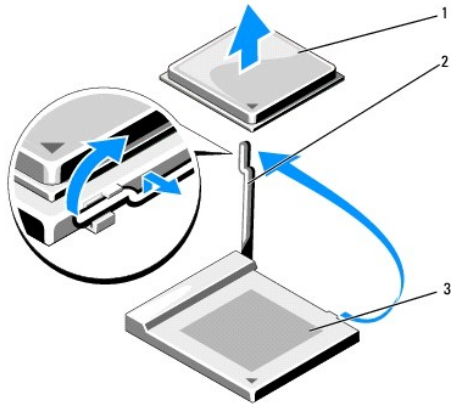

1	processor	2	release lever
3	socket		

➔ **NOTICE:** When replacing the processor, do not touch any of the pins inside the socket or allow any objects to fall on the pins in the socket.

7. Lift up the processor to remove it from the socket, place it aside in a safe and secure place.

Leave the release lever extended in the release position so that the socket is ready for the new processor.

Installing the Processor

➔ **NOTICE:** Ground yourself by touching an unpainted metal surface on the back of the computer.

➔ **NOTICE:** You must position the processor correctly in the socket to avoid permanent damage to the processor and the computer when you turn on the computer.

1. Follow the procedures in [Before You Begin](#).

2. Unpack the new processor, being careful not to touch the underside of the processor.

➔ **NOTICE:** Socket pins are delicate. To avoid damage, ensure that the processor is aligned properly with the socket, and do not use excessive force when you install the processor. Be careful not to touch or bend the pins on the system board.

Dell Inspiron 518

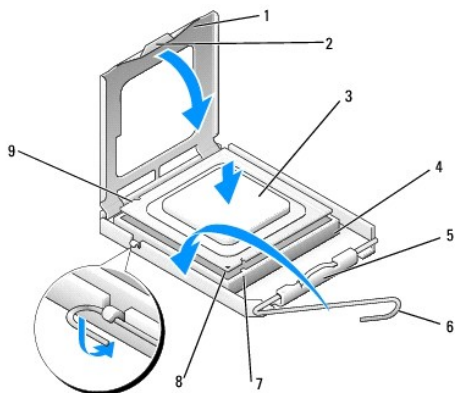

1	processor cover	2	tab
3	processor	4	processor socket
5	center cover latch	6	release lever
7	front alignment-notch	8	processor pin-1 indicator
9	rear alignment notch		

Dell Inspiron 519

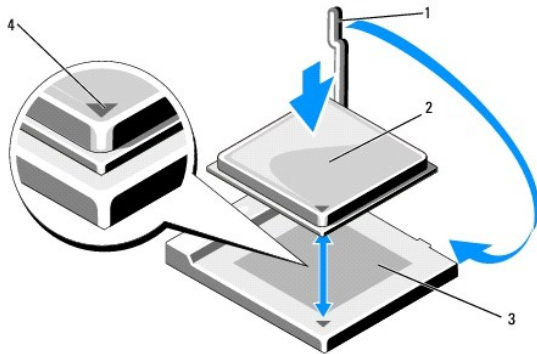

1	release lever	2	processor
3	socket	4	processor pin-1 indicator

3. If the release lever on the socket is not fully extended, move it to that position.

4. For Inspiron 518, orient the front and rear alignment-notches on the processor with the front and rear alignment-notches on the socket.

5. Align the pin-1 corners of the processor and socket.

➔ **NOTICE:** To avoid damage, ensure that the processor aligns properly with the socket, and do not use excessive force when you install the processor.

6. Set the processor lightly in the socket and ensure that the processor is positioned correctly.

7. When the processor is fully seated in the socket, close the processor cover, if applicable.

Ensure that the tab on the processor cover is positioned underneath the center cover latch on the socket.

8. Pivot the socket release lever back towards the socket, and snap it into place to secure the processor.

9. Clean the thermal grease from the bottom of the heat sink.

➔ **NOTICE:** Ensure that you apply new thermal grease. New thermal grease is critical for ensuring adequate thermal bonding, which is a requirement for optimal processor operation.

10. Apply the new thermal grease to the top of the processor.

11. Install the processor fan and heat sink assembly (see [Replacing the Processor Fan and Heat Sink Assembly](#)).

➔ **NOTICE:** Ensure that the processor fan and heat sink assembly is correctly seated and secure.

12. Replace the computer cover (see [Replacing the Computer Cover](#)).

13. Connect your computer and devices to electrical outlets, and then turn them on.

[Back to Contents Page](#)

Replacing Drives

Dell™ Inspiron™ 518/519 Service Manual

- [Replacing a Hard Drive](#)
- [Replacing a CD/DVD Drive](#)
- [Replacing a Media Card Reader](#)
- [Removing the FlexBay Break-Away Metal Plate](#)
- [Replacing the Drive Panel Insert](#)

CAUTION: Before working inside your computer, read the safety information that shipped with your computer. For additional safety best practices information, see the Regulatory Compliance Homepage at www.dell.com/regulatory_compliance.

NOTE: The system does not support IDE devices.

NOTE: The 3.5-inch media card reader is not interchangeable with the hard drive carrier.

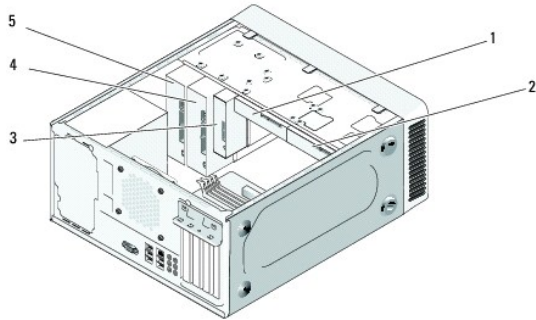

1	hard drive	2	optional hard drive
3	media card reader	4	optional CD or DVD drive
5	CD or DVD drive		

Replacing a Hard Drive

NOTICE: If you are replacing a hard drive that contains data you want to keep, back up your files before you begin this procedure.

1. Follow the procedures in [Before You Begin](#).
2. Remove the computer cover (see [Removing the Computer Cover](#)).
3. Disconnect the power and data cables from the drive.

NOTE: If you are not replacing the hard drive at this time, disconnect the other end of the data cable from the system board and set it aside. You can use the data cable to install a hard drive at a later time.

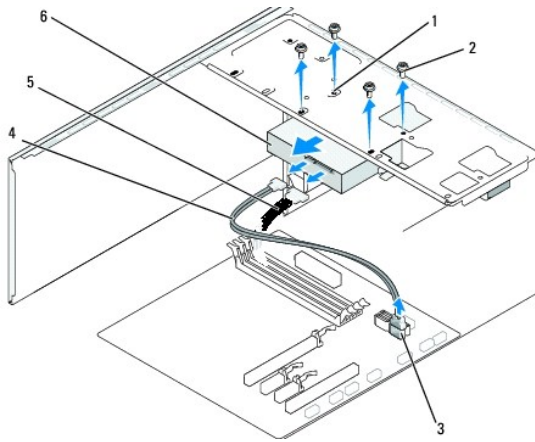

1	screw holes in the hard drive bay (4)	2	screws (4)
3	system board connector (any available connector SATA0 - SATA3)	4	serial ATA data cable
5	power cable	6	hard drive

4. Remove the four screws securing the hard drive to the chassis.

NOTICE: Ensure that you do not scratch the hard disk circuit board, while removing or replacing the hard drive.

5. Slide the drive out away from the front of the computer.

6. If you are replacing the drive or installing a new one, check the documentation for the drive to verify that it is configured for your computer.

7. Slide the hard drive into the hard drive bay.

8. Align the four screw holes in the hard drive with the screw holes in the hard drive bay.

9. Replace and tighten the four screws to secure the hard drive to the chassis.

10. Connect the power and data cables to the drive.

11. Ensure that all the cables are properly connected and firmly seated.

12. Replace the computer cover (see [Replacing the Computer Cover](#)).

13. Connect your computer and devices to electrical outlets, and then turn them on.

Replacing a CD/DVD Drive

1. Follow the procedures in [Before You Begin](#).

2. Remove the computer cover (see [Removing the Computer Cover](#)).

3. Remove the front panel(see [Replacing the Front Panel](#)).

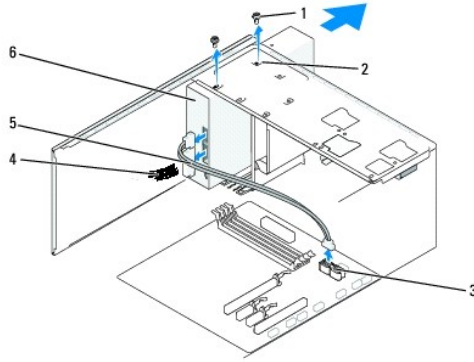

1	custom screws (2)	2	screw holes in the CD/DVD drive bay	3	system board connector (any available connector SATA0 - SATA3)
4	power cable	5	data cable	6	CD/DVD drive

4. Disconnect the power cable and the CD/DVD drive data cable from the back of the drive.

NOTE: If you are uninstalling the only CD/DVD drive in your computer and will not replace it at this time, disconnect the data cable from the system board and set it aside.

5. Remove the two screws securing the CD/DVD drive to the chassis.

6. Slide the CD/DVD drive out through the front of the computer.

7. If you are not replacing the drive:

- a. Replace the drive panel insert (see [Replacing the Drive Panel Insert](#)).
- b. Go to [step 12](#).

8. Gently slide the drive into place.

9. Align the screw holes in the CD/DVD drive with the screw holes in the CD/DVD drive bay.

10. Replace and tighten the two screws securing the CD/DVD drive to the chassis.

11. Connect the power and data cables to the drive.

12. Replace the front panel (see [Replacing the Front Panel](#)).

13. Replace the computer cover (see [Replacing the Computer Cover](#)).

14. Connect your computer and devices to their electrical outlets, and turn them on.

NOTE: If you installed a new drive, see the documentation that came with the drive for instructions on installing any software required for drive operation.

Replacing a Media Card Reader

1. Follow the procedures in [Before You Begin](#).

2. Remove the computer cover (see [Removing the Computer Cover](#)).

3. Remove the front panel (see [Replacing the Front Panel](#)).

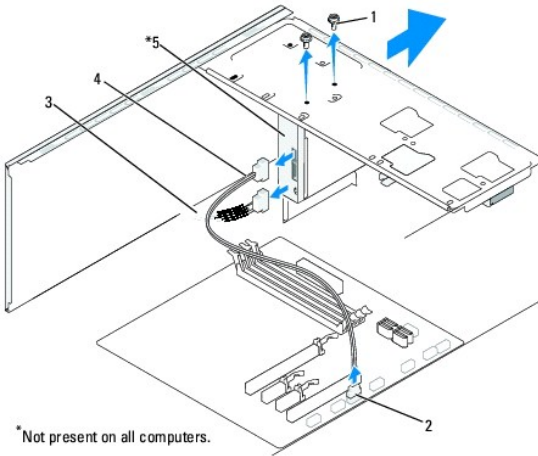

* Not present on all computers.

1	custom screws (2)	2	F_USB4 connector	3	power cable
4	flexbay USB cable	5	media card reader		

4. Disconnect the FlexBay USB cable and the power cable from the back of the Media Card Reader and from the internal USB connector (F_USB4) on the system board (see [System Board Components](#)).
5. Remove the two screws securing the Media Card Reader.
6. Slide the Media Card Reader out through the front of the computer.
7. If you are not reinstalling the Media Card Reader, replace the drive panel insert. See [Replacing the Drive Panel Insert](#).
8. If you are installing a new Media Card Reader:
 - a. Remove the drive panel insert (see [Replacing the Drive Panel Insert](#)).
 - b. Remove the Media Card Reader from its packaging.
9. Gently slide the Media Card Reader into place in the FlexBay slot.
10. Align the screw holes in the Media Card Reader with the screw holes in the FlexBay.
11. Tighten the two screws to secure the Media Card Reader.

 **NOTE:** Ensure that the Media Card Reader is installed before the FlexBay cable is connected.
12. Connect the FlexBay USB cable to the back of the Media Card Reader and to the internal USB connector (F_USB4) on the system board (see [System Board Components](#)).
13. Replace the front panel(see [Replacing the Front Panel](#)).
14. Replace the computer cover (see [Replacing the Computer Cover](#)).
15. Connect your computer and devices to electrical outlets, and then turn them on.

Removing the FlexBay Break-Away Metal Plate

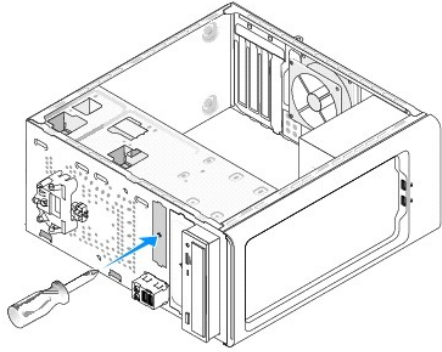

Align the tip of a Phillips screwdriver with the slot on the break-away metal plate and rotate the screwdriver outwards to break and remove the metal plate.

Replacing the Drive Panel Insert

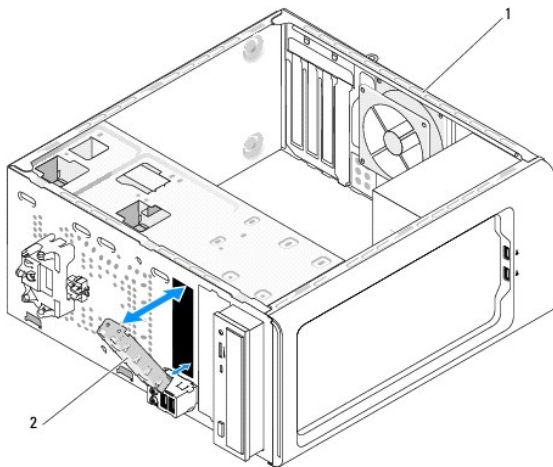

1	back of the computer	2	drive panel insert (optional)
---	----------------------	---	-------------------------------

Align the drive panel insert along the edges of the empty slot of the Media Card Reader and push the panel insert. The drive panel insert is locked in place.

NOTICE: To comply with FCC regulations, it is recommended that you replace the drive panel insert whenever the Media Card Reader is removed from the computer.

[Back to Contents Page](#)

Replacing Fans

Dell™ Inspiron™ 518/519 Service Manual

- [Replacing the Chassis Fan](#)
- [Replacing the Processor Fan and Heat Sink Assembly](#)

⚠ CAUTION: Before working inside your computer, read the safety information that shipped with your computer. For additional safety best practices information, see the Regulatory Compliance Homepage at www.dell.com/regulatory_compliance.

⚠ CAUTION: To guard against likelihood of electric shock, laceration by moving fan blades or other unexpected injuries, always unplug your computer from the electrical outlet before removing the cover.

Replacing the Chassis Fan

👉 NOTICE: Do not touch the fan blades when you are removing the chassis fan. This could damage the fan.

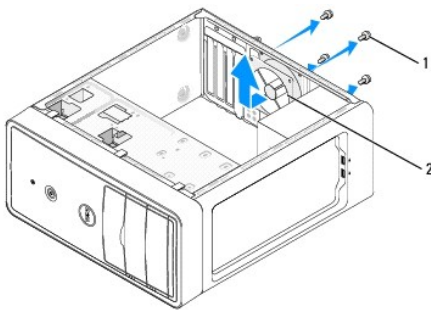

1	screws (4)	2	chassis fan
---	------------	---	-------------

1. Follow the procedures in [Before You Begin](#).
 2. Remove the computer cover (see [Removing the Computer Cover](#)).
 3. Disconnect the chassis fan cable from the system board connector (CHASSIS_FAN).
 4. Remove the four screws securing the chassis fan.
 5. Slide the chassis fan towards the front of the computer and lift it up.
 6. To install the chassis fan, slide it in place towards the back of the computer.
 7. Tighten the four screws to secure the chassis fan.
 8. Connect the chassis fan cable to the system board connector (CHASSIS_FAN).
 9. Replace the computer cover (see [Replacing the Computer Cover](#)).
-

Replacing the Processor Fan and Heat Sink Assembly

⚠ CAUTION: Despite having a plastic shield, the heat sink fan assembly may be very hot during normal operation. Be sure that it has had sufficient time to cool before you touch it.

👉 NOTICE: Do not touch the fan blades when you are removing the processor fan and heat sink assembly. This could damage the fan.

👉 NOTICE: The processor fan with the heat sink is one single unit. Do not try to remove the fan separately.

1. Follow the procedures in [Before You Begin](#).
2. Remove the computer cover (see [Removing the Computer Cover](#)).

3. Disconnect the processor fan cable from the CPU_FAN connector on the system board (see [System Board Components](#)).
4. Carefully move away any cables that are routed over the processor fan and heat sink assembly.
5. Follow the instructions below to replace the processor fan and heat sink assembly, depending on your computer model:

Inspiron 518

- a. Loosen the four captive screws securing the processor fan and heat sink assembly and lift it straight up.

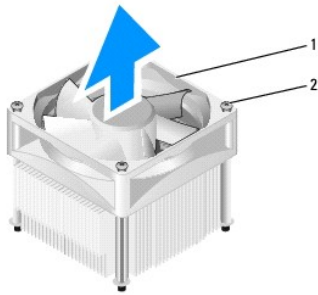

1	processor fan and heat sink assembly	2	captive screws (4)
---	--------------------------------------	---	--------------------

NOTE: The processor fan and heat sink assembly in your computer may not look exactly like the one shown in the illustration above.

- b. To reinstall the processor fan and heat sink assembly, align the captive screws on the processor fan and heat sink assembly to the four metal screw hole projections on the system board.
- c. Tighten the four captive screws.

Inspiron 519

- a. Rotate the clamp lever 180 degrees counter-clockwise to release the clamp grip from the bracket projection.
- b. Release the clamp grip from the bracket projection on the opposite side.
- c. Rotate the heat sink assembly upward gently, and remove it from the computer. Lay the heat sink assembly down on its top, with the thermal grease facing upward.

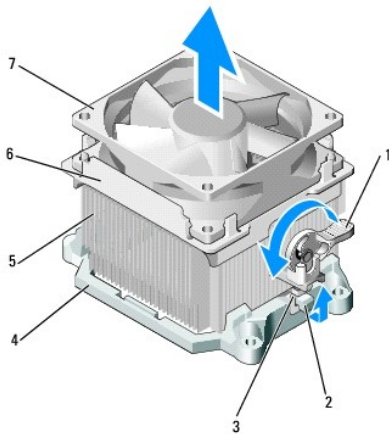

1	clamp lever	2	bracket projection	3	clamp grip
4	bracket	5	heat sink	6	fan cover
7	fan				

- d. Place the heat sink and fan assembly back onto the heat-sink assembly bracket.
- e. Ensure that the two clamp grips are aligned with the two bracket projections.

f. Hold the heat sink fan assembly in place and rotate the clamp lever 180 degrees clockwise to secure the heat sink and fan assembly.

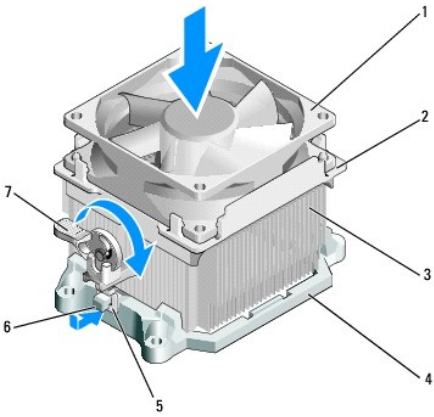

1	fan	2	fan cover	3	heat sink
4	bracket	5	clamp grip	6	bracket projection
7	clamp lever				

 **NOTE:** Ensure that the processor fan and heat sink assembly is correctly seated and secure.

6. Connect the processor fan and heat sink assembly cable to the CPU_FAN system board connector (see [System Board Components](#)).
7. Replace the computer cover (see [Replacing the Computer Cover](#)).
8. Connect your computer and devices to an electrical outlet, and turn them on.

[Back to Contents Page](#)

Replacing the Front Panel

Dell™ Inspiron™ 518/519 Service Manual

⚠ CAUTION: Before working inside your computer, read the safety information that shipped with your computer. For additional safety best practices information, see the Regulatory Compliance Homepage at www.dell.com/regulatory_compliance.

1. Follow the procedures in [Before You Begin](#).
2. Remove the computer cover (see [Removing the Computer Cover](#)).

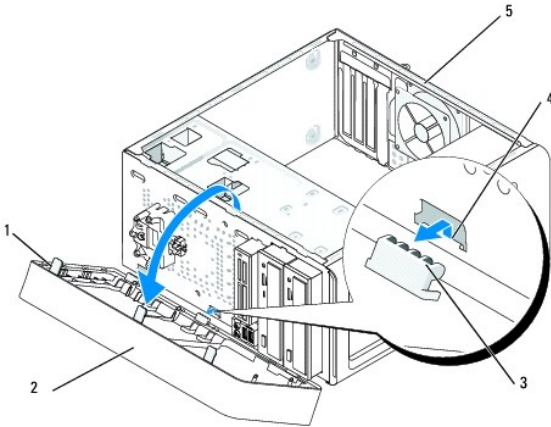

1	front panel grip (3)	2	front panel
3	front panel clamp (3)	4	clamp insert
5	back of the computer		

3. Grasp and lift the front panel grips one at a time to release it from the front of the computer.
 4. Rotate and pull the front panel away from the front of the computer to release the front panel clamps from the clamp insert.
 5. To reinstall the front panel, align and insert the front panel clamps in the clamp insert.
 6. Rotate the front panel towards the computer until it snaps into place on the front of the computer.
 7. Replace the computer cover (see [Replacing the Computer Cover](#)).
-

Replacing the Front I/O Panel

Dell™ Inspiron™ 518/519 Service Manual

⚠ CAUTION: Before working inside your computer, read the safety information that shipped with your computer. For additional safety best practices information, see the Regulatory Compliance Homepage at www.dell.com/regulatory_compliance.

1. Follow the procedures in [Before You Begin](#).
2. Remove the computer cover (see [Removing the Computer Cover](#)).
3. Remove the front panel (see [Replacing the Front Panel](#)).
4. Remove any expansion cards (see [Replacing a PCI/PCI Express Card](#)).

🔍 NOTICE: Carefully note the routing of each cable before you disconnect it, so that you are sure to re-route cables correctly. An incorrectly routed or a disconnected cable could lead to computer problems.

5. Disconnect all the cables that are connected to the I/O panel from the system board.
6. Remove the screw that secures the I/O panel to the chassis.
7. Carefully remove the existing I/O panel from the computer.

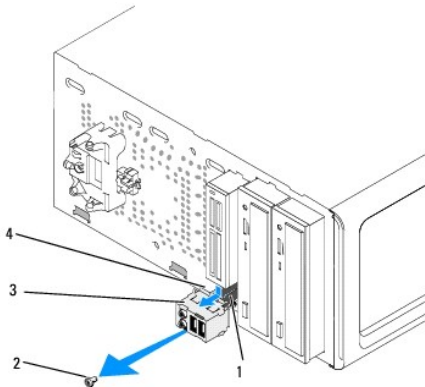

1	cables	2	screw
3	I/O panel	4	I/O panel clamp

8. To install a new I/O panel, align and slide the I/O panel clamp into the I/O panel clamp slot.
9. Replace and tighten the screw that secures the I/O panel to the chassis.
10. Reconnect the cables to the system board.
11. Replace the front panel (see [Replacing the Front Panel](#)).
12. Replace the computer cover (see [Replacing the Computer Cover](#)).
13. Connect your computer and devices to an electrical outlet, and turn them on.

Replacing Memory Module(s)

Dell™ Inspiron™ 518/519 Service Manual

CAUTION: Before working inside your computer, read the safety information that shipped with your computer. For additional safety best practices information, see the Regulatory Compliance Homepage at www.dell.com/regulatory_compliance.

1. Follow the procedures in [Before You Begin](#).
2. Remove the computer cover (see [Removing the Computer Cover](#)).
3. Locate the memory modules on the system board (see [System Board Components](#)).
4. Press out the securing clip at each end of the memory module connector.

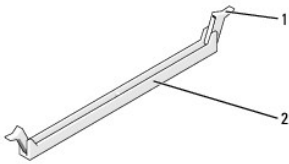

1	securing clip	2	memory module connector
---	---------------	---	-------------------------

5. Grasp the module and pull it upwards.

If the module is difficult to remove, gently ease the module back and forth to remove it from the connector.

NOTICE: Do not install ECC memory modules.

NOTICE: If you remove your original memory modules from the computer during a memory upgrade, keep them separate from any new modules that you may have, even if you purchased the new modules from Dell™. If possible, do not pair an original memory module with a new memory module. Otherwise, your computer may not start properly. The recommended memory configurations are:
A pair of matched memory modules installed in DIMM connectors 1 and 2 or
A pair of matched memory modules installed in DIMM connectors 3 and 4.

NOTE: If you install mixed pairs of PC2-5300 (DDR2 667-MHz) and PC2-6400 (DDR2 800-MHz) memory, the modules function at the speed of the slowest module installed.

6. Follow the instructions below to install memory modules, depending on your computer model:

For Inspiron™ 518 — Ensure that you install a single memory module in DIMM connector 1, the connector closest to the processor, before you install modules in any other connector.

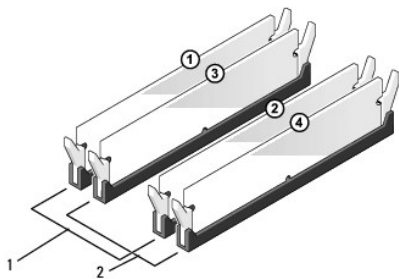

1	Pair A: matched pair of memory modules in connectors DIMM_1 and DIMM_2	2	Pair B: matched pair of memory modules in connectors DIMM_3 and DIMM_4
---	--	---	--

For Inspiron 519 — Ensure that you install a single memory module in DIMM connector 1, the connector farthest to the processor, before you install modules in any other connector.

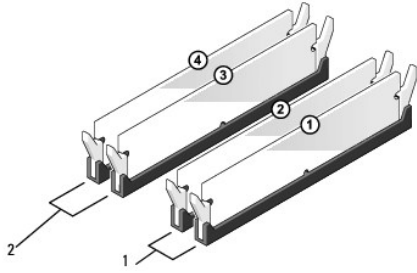

1	Pair A: matched pair of memory modules in connectors DIMM_1 and DIMM_2	2	Pair B: matched pair of memory modules in connectors DIMM_3 and DIMM_4
---	--	---	--

7. Align the notch on the bottom of the module with the crossbar in the connector.

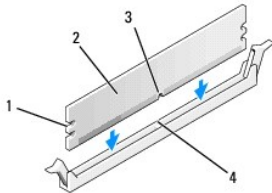

1	cutouts (2)	2	memory module
3	notch	4	crossbar

NOTICE: To avoid damage to the memory module, press the module straight down into the connector while you apply equal force to each end of the module.

8. Insert the module into the connector until the module snaps into position.

If you insert the module correctly, the securing clips snap into the cutouts at each end of the module.

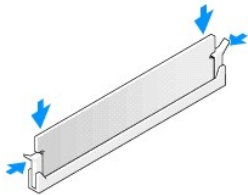

9. Replace the computer cover (see [Replacing the Computer Cover](#)).

10. Connect your computer and devices to electrical outlets, and then turn them on.

11. When the message appears stating that memory size has changed, press <F1> to continue.

12. Log on to your computer.

13. Right-click the **My Computer** icon on your Windows desktop and click **Properties**.

14. Click the **General** tab.

15. To verify that the memory is installed correctly, check the amount of memory (RAM) listed.

Replacing the Power Supply

Dell™ Inspiron™ 518/519 Service Manual

⚠ CAUTION: Before working inside your computer, read the safety information that shipped with your computer. For additional safety best practices information, see the Regulatory Compliance Homepage at www.dell.com/regulatory_compliance.

⚠ CAUTION: To guard against likelihood of electric shock, laceration by moving fan blades or other unexpected injuries, always unplug your computer from the electrical outlet before removing the cover.

1. Follow the procedures in [Before You Begin](#).
2. Remove the computer cover (see [Removing the Computer Cover](#)).

➡ NOTICE: Note the location and ID of each power connector before disconnecting the power supply cables.

3. Follow the DC power cables that stem from the power supply and disconnect each connected power cable.

🔍 NOTE: Note the routing of the DC power cables underneath the tabs in the computer chassis as you remove them from the system board and drives. You must route these cables properly when you replace them to prevent them from being pinched or crimped.

4. Remove the four screws that attach the power supply to the back of the computer chassis.

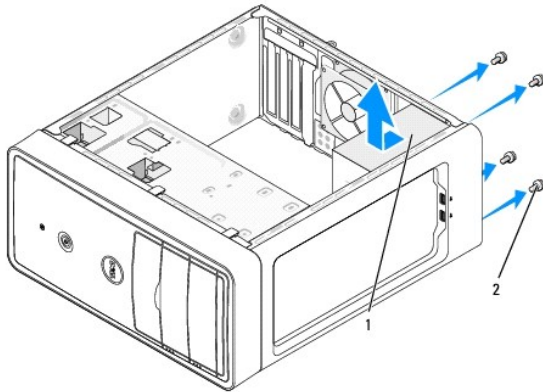

1	power supply	2	screws (4)
---	--------------	---	------------

5. Slide out the power supply and lift it out.
6. Slide the replacement power supply towards the back of the computer.

⚠ CAUTION: Failure to replace and tighten all screws may cause electrical shock as these screws are a key part of the system grounding.

7. Replace and tighten all screws that secure the power supply to the back of the computer chassis.

➡ NOTICE: Route the DC power cables under the chassis tabs. The cables must be properly routed to prevent the cables from being damaged.

8. Reconnect the DC power cables to the system board and drives.

🔍 NOTE: Double-check all cable connections to make sure they are secure.

9. Replace the computer cover (see [Replacing the Computer Cover](#)).
 10. Connect your computer and devices to an electrical outlet, and turn them on.
-

[Back to Contents Page](#)

Replacing the System Board

Dell™ Inspiron™ 518/519 Service Manual

CAUTION: Before working inside your computer, read the safety information that shipped with your computer. For additional safety best practices information, see the Regulatory Compliance Homepage at www.dell.com/regulatory_compliance.

NOTICE: Do not perform the following steps unless you are familiar with hardware removal and replacement. Performing these steps incorrectly could damage your system board. For technical service, see the *Quick Reference Guide*.

1. Follow the procedures in [Before You Begin](#).
2. Remove the computer cover (see [Removing the Computer Cover](#)).
3. Remove any add-in cards on the system board (see [Replacing a PCI/PCI Express Card](#)).

CAUTION: The processor heat sink can get very hot during normal operation. Be sure that the heat sink has had sufficient time to cool before you touch it.

4. Remove the processor and heat sink assembly (see [Removing the Processor](#)).
5. Remove the memory modules (see [Replacing Memory Module\(s\)](#)) and document which memory module is removed from each memory socket so that the memory modules can be installed in the same location after the board is replaced.

NOTICE: Carefully note the routing and location of each cable before you disconnect it, so that you are sure to re-route cables correctly. An incorrectly routed or a disconnected cable could lead to computer problems.

6. Disconnect all cables from the system board.
7. Remove the eight screws from the system board.

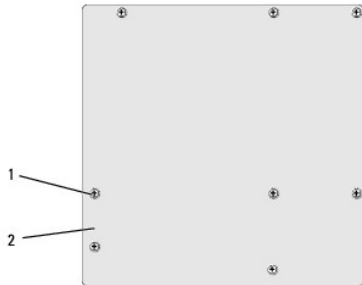

1	screws (8)	2	system board
---	------------	---	--------------

8. Lift the system board up and out.

NOTICE: If you are replacing the system board, visually compare the replacement system board to the existing system board to make sure that you have the correct part.

NOTE: Some components and connectors on replacement system boards may be in different locations than corresponding connectors on the existing system board.

NOTE: Jumper settings on replacement system boards are preset at the factory.

9. Orient the system board by aligning the screw holes on the system board with the screw holes on the chassis.
10. Replace the eight screws to secure the system board to the chassis.
11. Replace the cables that you removed from the system board.
12. Replace the processor and the heat sink assembly (see [Installing the Processor](#)).

NOTICE: Ensure that the heat sink assembly is correctly seated and secure.

13. Replace the memory modules into the memory sockets at the same locations from which you removed them (see [Replacing Memory Module\(s\)](#)).
14. Replace any add-in cards on the system board.
15. Replace the computer cover (see [Replacing the Computer Cover](#)).
16. Connect your computer and devices to an electrical outlet, and turn them on.
17. Flash the system BIOS, as needed.

 **NOTE:** For information on flashing the system BIOS, see [Flashing the BIOS](#).

[Back to Contents Page](#)

System Setup

Dell™ Inspiron™ 518/519 Service Manual

- [Overview](#)
- [Clearing Forgotten Passwords](#)
- [Clearing CMOS Settings](#)
- [Flashing the BIOS](#)

Overview

Use system setup to:

- 1 Change the system configuration information after you add, change, or remove any hardware in your computer
- 1 Set or change a user-selectable option such as the user password
- 1 Read the current amount of memory or set the type of hard drive installed

 **NOTICE:** Unless you are an expert computer user, do not change the settings for this program. Certain changes can make your computer work incorrectly.

 **NOTE:** Before you use system setup, it is recommended that you write down the system setup screen information for future reference.

Entering System Setup

1. Turn on (or restart) your computer.
2. When the blue DELL™ logo is displayed, watch for the F2 prompt to appear and then press <F2> immediately.

 **NOTE:** The F2 prompt indicates that the keyboard has initialized. This prompt can appear very quickly, so you must watch for it to display, and then press <F2>. If you press <F2> before you are prompted, this keystroke will be lost. If you wait too long and the operating system logo appears, continue to wait until you see the Microsoft® Windows® desktop. Then, shut down your computer (see [Turning Off Your Computer](#)) and try again.

System Setup Screens

The system setup screen displays current or changeable configuration information for your computer. Information on the screen is divided into three areas: the options list, active options field, and key functions.

Options List — This field appears on the top of the system setup window. The tabbed options contain features that define the configuration of your computer, including installed hardware, power conservation, and security features.

Option Field — This field contains information about each option. In this field you can view your current settings and make changes to your settings. Use the right- and left-arrow keys to highlight an option. Press <Enter> to make that selection active.

Help Field — This field provides context sensitive help based on the options selected.

Key Functions — This field appears below the Option Field and lists keys and their functions within the active system setup field.

System Setup Options — Dell Inspiron™ 518

 **NOTE:** Depending on your computer and installed devices, the items listed in this section may not appear, or may not appear exactly as listed.

System Info	
System	Inspiron 518
BIOS Info	Shows the BIOS version number and date information
Service Tag	Shows the service tag of the computer
Asset Tag	Shows the asset tag for the computer if present.
CPU Info	Lists the processor bus speed, processor ID, clock speed, and L2 cache.
Memory Info	Indicates amount of installed memory, memory speed, channel mode (dual or single), and type of memory installed.
Standard CMOS Features	
Date/Time	Displays current date and time settings. Date in the mm:dd:yy format and time in the hh:mm:ss format.
SATA Info	Displays the SATA drives integrated in the system (SATA-0; SATA-1; SATA-2; SATA-3; SATA-4; SATA-5).
SATA HDD Auto-Detection	Auto detects the SATA connector to which the hard drive is attached.

Capacity	The combined installed capacity of all the SATA devices.
Halt On	All Error; All, But Keyboard (All, But Keyboard by default).
Advanced BIOS Features	
CPU Feature	<ul style="list-style-type: none"> 1 Limit CUID Value—Enabled; Disabled (Disabled by default) 1 Execute Disable Bit—Enabled; Disabled (Enabled by default) 1 Virtualization Technology—Enabled; Disabled (Enabled by default) 1 Core Multi-Processing—Enabled; Disabled (Enabled by default)
Boot Up NumLock	Off; On (On by default)
Boot Device Configuration	
Removable Device Priority	Used to set the device priority of removable devices like USB floppy drives. The items displayed are dynamically updated according to the removable devices connected.
Hard Disk Boot Priority	Used to set the device priority of hard drives. The items displayed are dynamically updated according to the hard drives detected.
First Boot Device	Removable; Hard Disk; CDROM; USB-CDROM; Legacy LAN; Disabled (Removable by default)
Second Boot Device	Removable; Hard Disk; CDROM; USB-CDROM; Legacy LAN; Disabled (Hard disk by default)
Third Boot Device	Removable; Hard Disk; CDROM; USB-CDROM; Legacy LAN; Disabled (CD-ROM by default)
Boot Other Device	Enabled; Disabled (Disabled by default)
Advanced Chipset Features	
Init Display First	PCI Slot, Onboard (PCI Slot by default)
Video Memory Size	1 MB, 8 MB (8 MB by default)
Integrated Peripherals	
USB Device Setting	<ul style="list-style-type: none"> 1 USB Controller—Enabled or Disabled (Enabled by default) 1 USB Operation Mode—High Speed; Full/Low Speed (High Speed by default)
Onboard Audio Controller	Enabled or Disabled (Enabled by default)
Onboard LAN Controller	Enabled or Disabled (Enabled by default)
Onboard LAN Boot ROM	Enabled or Disabled (Disabled by default)
SATA Mode	IDE; RAID (IDE by default)
Power Management Setup	
ACPI Suspend Type	S1(POS); S3(STR) (S3(STR) by default)
Remote Wake Up	On; Off (On by default)
Auto Power On	Enabled; Disabled (Disabled by default)
Auto Power On Date	0
Auto Power On Time	0:00:00
AC Recovery	Off; On; Last (Off by default)

System Setup Options – Dell Inspiron 519

 **NOTE:** Depending on your computer and installed devices, the items listed in this section may not appear, or may not appear exactly as listed.

System Info	
System	Inspiron 519
BIOS Info	Shows the BIOS version number and date information
Service Tag	Shows the service tag of the computer
Asset Tag	Shows the asset tag for the computer if present.
CPU Info	Lists the processor bus speed, processor ID, clock speed, and L2 cache.
Memory Info	Indicates amount of installed memory, available memory, memory speed, channel mode (dual or single), and type of memory installed.
Standard CMOS Features	
Date/Time	Displays current date and time settings. Date in the mm:dd:yy format and time in the hh:mm:ss format.
SATA Info	Displays the SATA drives integrated in the system (SATA-0; SATA-1; SATA-2; SATA-3)
Advanced BIOS Features	
CPU Feature	<ul style="list-style-type: none"> 1 AMD™ Virtualization—Enabled; Disabled (Disabled by default) 1 AMD Cool 'N' quiet Function—Enabled; Disabled (Enabled by default) 1 AMD Live!—Indicates if the AMD Live! feature is available or not
USB Device Setting	High Speed; Full/Low Speed (High Speed by default)
Boot Device Configuration	

Fast Boot	Disabled; Enabled (Enabled by default)
NumLock Key	OFF; ON (On by default)
Keyboard Errors	Report; Do Not Report (Report by default)
Removable Device Priority	Used to set the device priority of removable devices like USB floppy drives. The items displayed are dynamically updated according to the removable devices connected.
Hard Disk Boot Priority	Used to set the device priority of hard drives. The items displayed are dynamically updated according to the hard drives detected.
First Boot Device	Removable; Hard Disk; CD/DVD; Disabled (Removable by default)
Second Boot Device	Removable; CD/DVD; Hard Drive; Disabled (CD/DVD by default)
Third Boot Device	Removable; CD/DVD; Hard Drive; Disabled (Hard Drive by default)
Boot Other Device	No; Yes (Yes by default)
Advanced Chipset Features	
Init Display First	PCI-E 16X Slot; PCI-E 1X Slot; PCI Slot; Onboard (PCI-E Slot by default)
UMA Frame Buffer Size	Auto; 32MB; 64MB; 128MB; 256MB; 512MB (Auto by default)
Onboard Audio Controller	Auto; Disabled; Enabled (Enabled by default)
Onboard LAN Controller	Disabled; Enabled (Enabled by default)
Onboard LAN Boot ROM	Disabled; Enabled (Disabled by default)
USB Device Setting	<ul style="list-style-type: none"> USB Controller—Enabled or Disabled (Enabled by default) USB Operation Mode—High Speed; Full/Low Speed (High Speed by default)
Power Management Setup	
ACPI Suspend Type	S1(POS); S3(STR) (S3(STR) by default)
C1E Support	Disabled; Enabled (Disabled by default)
Remote Wake Up	Disabled; Enabled (Enabled by default)
AC Recovery	Off; On; Last (Off by default)
Auto Power On	Enabled; Disabled (Disabled by default)
Auto Power On Date	Everyday; 0-30 (Date by default)
Auto Power On Time	00:00:00-23:59:50 (Displayed in hh:mm:ss format)
BIOS Security Features	
Supervisor Password	Status of supervisor installed
User Password	Status of user installed
Set Supervisor Password	Enter the desired Supervisor Password
User Access Level	No Access; View Only; Limited; Full Access (View Only by default)
Set User Password	Enter the desired User Password
Password Check	Setup; Always (Setup by default)
Clear User Password	Press Enter to clear user passwords

Boot Sequence

This feature allows you to change the boot sequence for devices.

Boot Options

- | **Hard Drive** — The computer attempts to boot from the primary hard drive. If no operating system is on the drive, the computer generates an error message.
- | **CD/DVD Drive** — The computer attempts to boot from the CD/DVD drive. If no CD/DVD is in the drive, or if the CD/DVD has no operating system, the computer generates an error message.
- | **USB Flash Device** — Insert the memory device into a USB port and restart the computer. When **F12 = Boot Menu** appears in the upper-right corner of the screen, press <F12>. The BIOS detects the device and adds the USB flash option to the boot menu.

 **NOTE:** To boot to a USB device, the device must be bootable. To ensure that your device is bootable, check the device documentation.

Changing Boot Sequence for the Current Boot

You can use this feature, for example, to tell the computer to boot from the CD drive so that you can run the Dell Diagnostics on the *Drivers and Utilities* media, but you want the computer to boot from the hard drive when the diagnostic tests are complete. You can also use this feature to restart your computer to a

USB device such as a USB floppy drive, or a memory key.

1. If you are booting to a USB device, connect the USB device to a USB connector.
2. Turn on (or restart) your computer.
3. When **F2 = Setup**, **F12 = Boot Menu** appears in the upper-right corner of the screen, press <F12>.

If you wait too long and the operating system logo appears, continue to wait until you see the Microsoft Windows desktop. Then shut down your computer and try again.

The **Boot Device Menu** appears, listing all available boot devices. Each device has a number next to it.

4. On the **Boot Device Menu** choose the device you want to boot from.

For example, if you are booting to a USB memory key, highlight **USB Flash Device** and press <Enter>.

 **NOTE:** To boot to a USB device, the device must be bootable. To ensure your device is bootable, check the device documentation.

Changing Boot Sequence for Future Boots

1. Enter system setup (see [Entering System Setup](#)).
2. Use the arrow keys to highlight the **Boot Device Configuration** menu option and press <Enter> to access the menu.

 **NOTE:** Write down your current boot sequence in case you want to restore it.

3. Press the up- and down-arrow keys to move through the list of devices.
4. Press plus (+) or minus (-) to change the boot priority of device.

Clearing Forgotten Passwords

 **CAUTION:** Before you begin any of the procedures in this section, follow the safety instructions located that shipped with your computer.

1. Follow the procedures in [Before You Begin](#).
2. Remove the computer cover (see [Removing the Computer Cover](#)).
3. Locate the 3-pin password connector (CLEAR_PW) on the system board (see [System Board Components](#)).

Inspiron™ 518

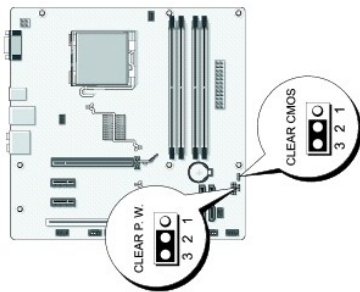

Inspiron 519

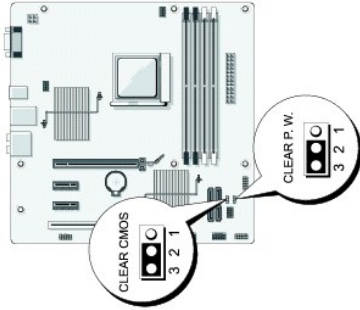

4. Remove the 2-pin jumper plug from pins 2 and 3 and fix it on pins 1 and 2.
 5. Wait for approximately five seconds to clear the password.
 6. Remove the 2-pin jumper plug from pins 1 and 2 and replace it on pins 2 and 3 to enable the password feature.
 7. Replace the computer cover (see [Replacing the Computer Cover](#)).
 8. Connect your computer and devices to electrical outlets, and turn them on.
-

Clearing CMOS Settings

CAUTION: Before you begin any of the procedures in this section, follow the safety instructions located that shipped with your computer.

1. Follow the procedures in [Before You Begin](#).

NOTICE: The computer must be disconnected from the electrical outlet to clear the CMOS setting.

2. Remove the computer cover (see [Removing the Computer Cover](#)).
 3. Reset the current CMOS settings:
 - a. Locate the 3-pin CMOS jumper (CLEAR CMOS) on the system board (see [System Board Components](#)).
 - b. Remove the jumper plug from the CMOS jumper (CLEAR CMOS) pins 2 and 3.
 - c. Place the jumper plug on the CMOS jumper (CLEAR CMOS) pins 1 and 2 and wait approximately five seconds.
 - d. Remove the jumper plug and replace it on the CMOS jumper (CLEAR CMOS) pins 2 and 3.
 4. Replace the computer cover (see [Replacing the Computer Cover](#)).
 5. Connect your computer and devices to electrical outlets, and turn them on.
-

Flashing the BIOS

The BIOS may require flashing when an update is available or when replacing the system board.

1. Turn on the computer.
2. Locate the BIOS update file for your computer at the Dell Support website at support.dell.com.
3. Click **Download Now** to download the file.
4. If the **Export Compliance Disclaimer** window appears, click **Yes, I Accept this Agreement**.
The **File Download** window appears.
5. Click **Save this program to disk**, and then click **OK**.
The **Save In** window appears.

6. Click the down arrow to view the **Save In** menu, select **Desktop**, and then click **Save**.

The file downloads to your desktop.

7. Click **Close** when the **Download Complete** window appears.

The file icon appears on your desktop and is titled the same as the download BIOS update file.

8. Double-click the file icon on the desktop and follow the instructions on the screen.

[Back to Contents Page](#)

[Back to Contents Page](#)

Technical Overview

Dell™ Inspiron™ 518/519 Service Manual

- [Inside View of Your Computer](#)
- [System Board Components](#)

⚠ CAUTION: Before working inside your computer, read the safety information that shipped with your computer. For additional safety best practices information, see the Regulatory Compliance Homepage at www.dell.com/regulatory_compliance.

Inside View of Your Computer

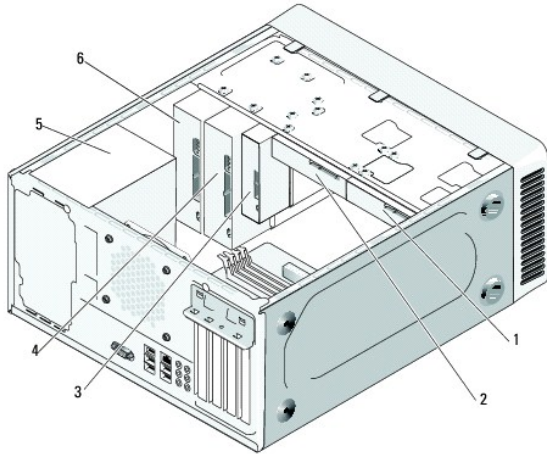

1	optional hard drive	2	hard drive
3	media card reader	4	optional CD or DVD drive
5	power supply	6	CD or DVD drive

System Board Components

Dell™ Inspiron™ 518

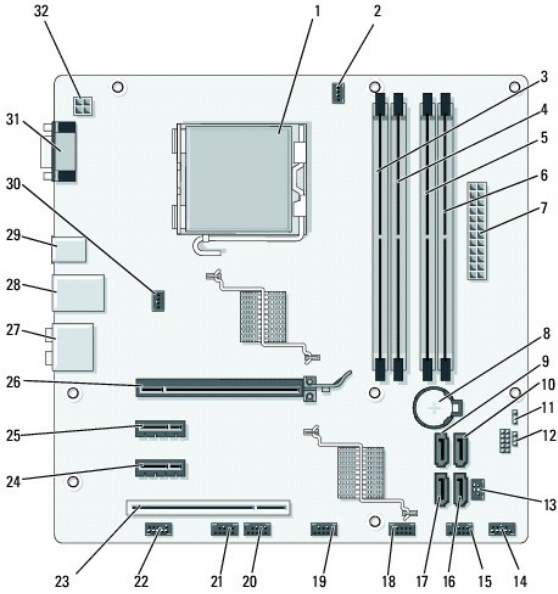

1	processor socket (CPU)	2	processor fan connector (CPU_FAN)
3	memory module connector (DIMM_1)	4	memory module connector (DIMM_3)
5	memory module connector (DIMM_2)	6	memory module connector (DIMM_4)
7	main power connector (ATX_POWER)	8	battery socket
9	serial ATA drive connector (SATA0)	10	serial ATA drive connector (SATA1)
11	password jumper (CLEAR_PW)	12	CMOS jumper (CLEAR CMOS)
13	S/PDIF connector (SPDIF_OUT)	14	front panel connector (F_PANEL)
15	Top USB connector (F_USB1)	16	serial ATA drive connector (SATA2)
17	serial ATA drive connector (SATA3)	18	front USB connector (F_USB2)
19	front USB connector (F_USB3)	20	front FlexBay connector (F_USB4)
21	front 1394 connector (F_1394)	22	front audio (F_AUDIO)
23	PCI connector (PCI 2.3)	24	PCI Express x1 connector (PCIE_X1)
25	PCI Express x1 connector (PCIE_X2)	26	PCI Express x16 connector (PCIE_X16)
27	audio connectors	28	2 USB connectors and 1 LAN connector
29	2 USB connectors and 1 IEEE 1394 connector	30	chassis fan connector (CHASSIS_FAN)
31	video connector (VGA)	32	power for processor (ATX_CPU)

Dell Inspiron 519

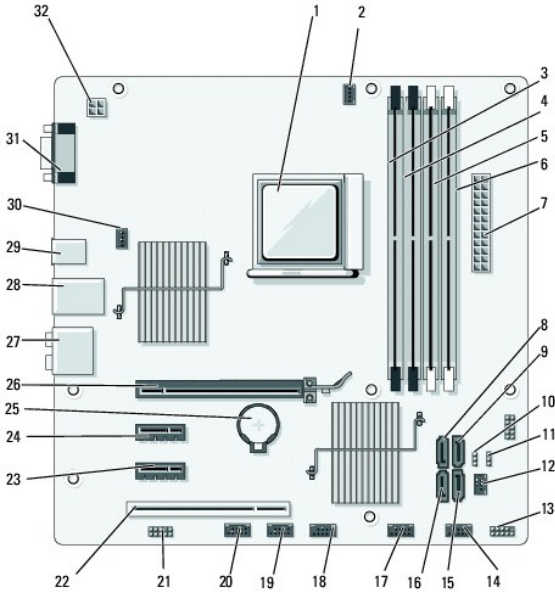

1	processor socket (CPU)	2	processor fan connector (CPU_FAN)
3	memory module connector (DIMM_4)	4	memory module connector (DIMM_3)
5	memory module connector (DIMM_2)	6	memory module connector (DIMM_1)
7	main power connector (ATX_POWER)	8	serial ATA drive connector (SATA3)
9	serial ATA drive connector (SATA2)	10	CMOS jumper (CLEAR CMOS)
11	password jumper (CLEAR_PW)	12	S/PDIF connector (SPDIF_OUT)
13	front panel connector (F_PANEL)	14	top USB connector (F_USB2)
15	serial ATA drive connector (SATA1)	16	serial ATA drive connector (SATA0)
17	front USB connector (F_USB3)	18	front USB connector (F_USB1)
19	front FlexBay connector (F_USB4)	20	front 1394 connector (F_1394)
21	front audio (F_AUDIO)	22	PCI connector (PCI 2.3)
23	PCI Express x1 connector (PCI_E_X1)	24	PCI Express x1 connector (PCI_E_X2)
25	battery socket	26	PCI Express x16 connector (PCI_E_X16)
27	audio connectors	28	2 USB connectors and 1 LAN connector
29	2 USB connectors and 1 IEEE 1394 connector	30	chassis fan connector (CHASSIS_FAN)
31	video connector (VGA)	32	power for processor (ATX_CPU)

[Back to Contents Page](#)