



About Warnings



WARNING: A WARNING indicates a potential for property damage, personal injury or death.

Dell™ Vostro™ 1320/1520/1720 Setup and Features Information

Vostro 1320

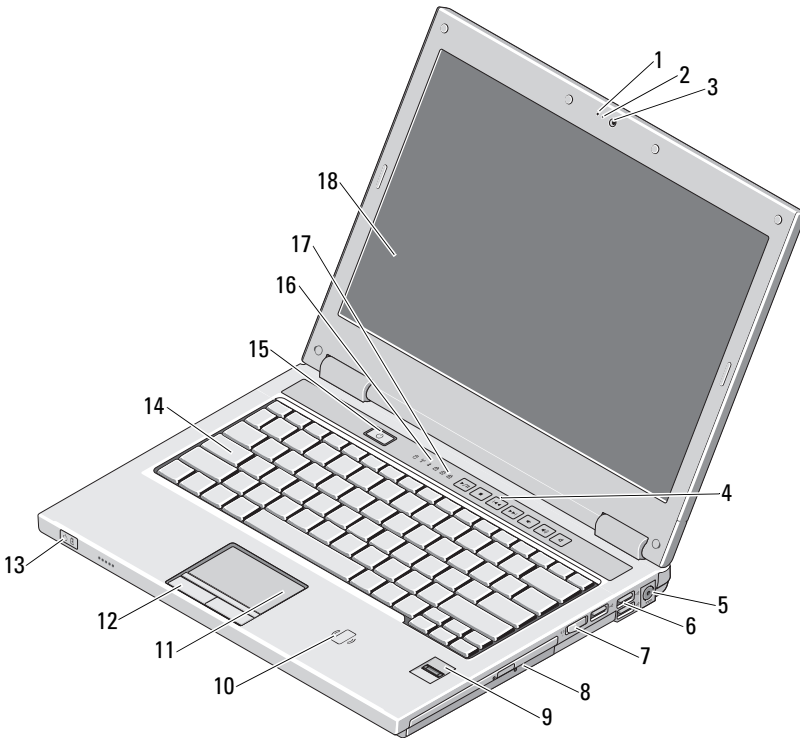

February 2009



0X951MA00

Models PP36S, PP36L, PP36X

- | | | | |
|----|--|----|---|
| 1 | microphone (optional) | 2 | camera light (optional) |
| 3 | camera (optional) | 4 | media controls (volume, forward, reverse, stop, play, and mute) |
| 5 | AC adapter connector | 6 | USB connectors (3) |
| 7 | wireless switch | 8 | optical device in media bay |
| 9 | fingerprint reader (optional) | 10 | contactless smart card reader (available in Japan only) |
| 11 | touch pad | 12 | touch pad buttons (2) |
| 13 | power and battery charge status lights | 14 | keyboard |
| 15 | power button | 16 | device status lights |
| 17 | keyboard status lights | 18 | display |

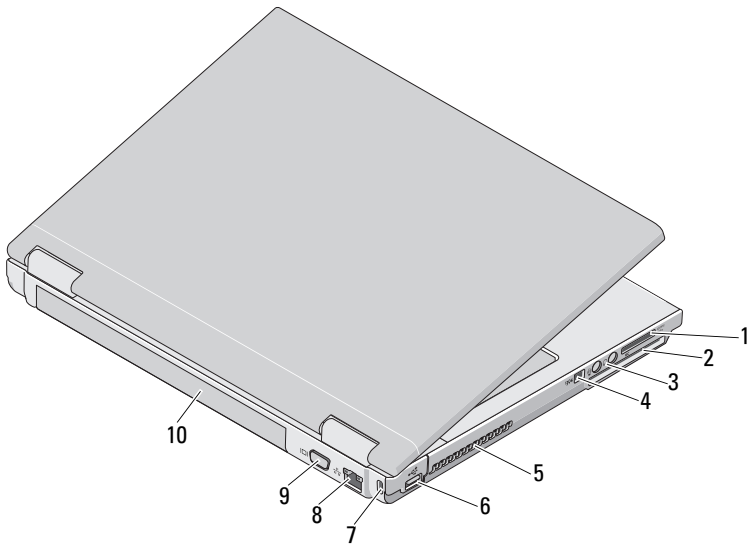

- | | | | |
|---|-------------------------|----|---------------------|
| 1 | 8-in-1 card reader slot | 2 | ExpressCard/54 slot |
| 3 | audio connectors (2) | 4 | IEEE 1394 connector |
| 5 | cooling vents | 6 | USB connector |
| 7 | security cable slot | 8 | network connector |
| 9 | VGA connector | 10 | battery |

Vostro 1520

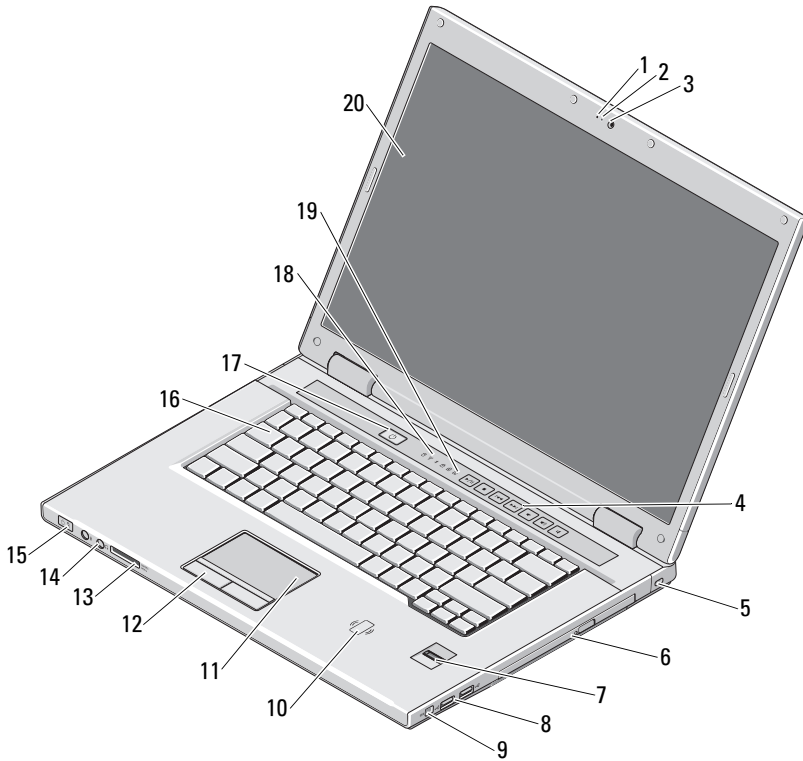

- | | | | |
|----|-------------------------------|----|---|
| 1 | microphone (optional) | 2 | camera light (optional) |
| 3 | camera (optional) | 4 | media controls (volume, forward, reverse, stop, play, and mute) |
| 5 | security cable slot | 6 | optical drive/media bay |
| 7 | fingerprint reader (optional) | 8 | USB connectors (2) |
| 9 | IEEE 1394 connector | 10 | contactless smart card reader (available in Japan only) |
| 11 | touch pad | 12 | touch pad buttons (2) |
| 13 | 8-in-1 card reader slot | 14 | audio connectors (2) |

- | | | | |
|----|--|----|----------------------|
| 15 | power and battery charge status lights | 16 | keyboard |
| 17 | power button | 18 | device status lights |
| 19 | keyboard status lights | 20 | display |

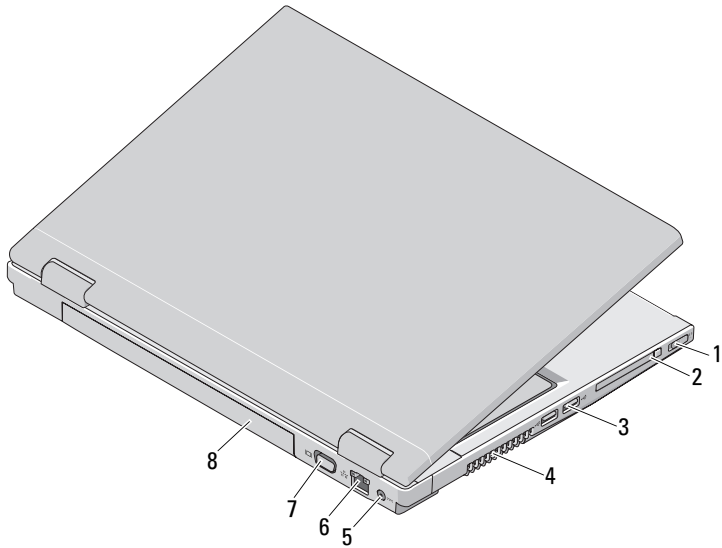

- | | | | |
|---|----------------------|---|---------------------|
| 1 | wireless switch | 2 | ExpressCard/54 slot |
| 3 | USB connectors (2) | 4 | cooling vents |
| 5 | AC Adapter connector | 6 | network connector |
| 7 | VGA connector | 8 | battery |

Vostro 1720

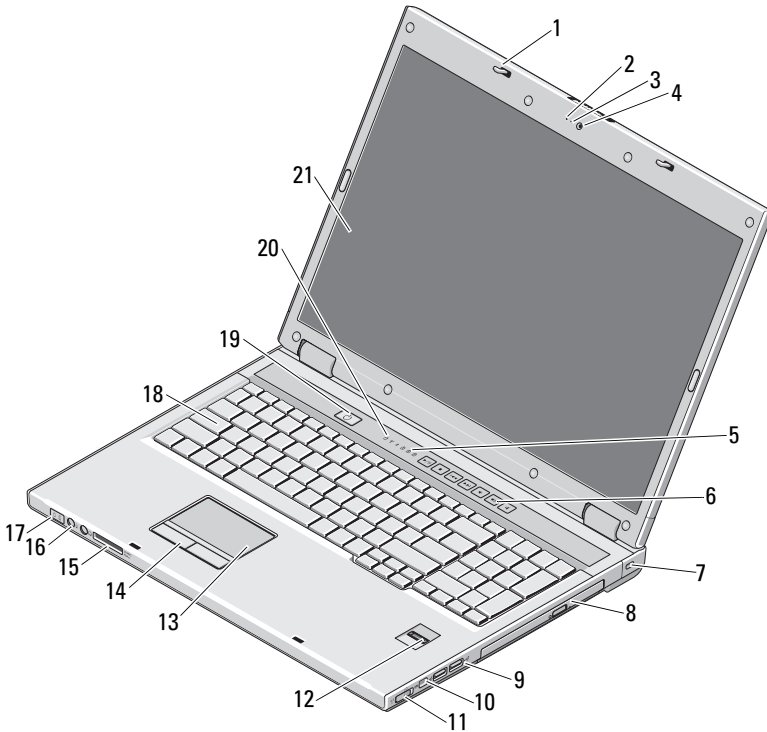

- | | | | |
|----|-------------------------|----|---|
| 1 | latches (2) | 2 | microphone (optional) |
| 3 | camera light (optional) | 4 | camera (optional) |
| 5 | keyboard status lights | 6 | media control button (volume, forward, reverse, stop, play, and mute) |
| 7 | security lock | 8 | optical drive/media bay |
| 9 | USB connectors (2) | 10 | IEEE 1394 connector |
| 11 | wireless switch | 12 | fingerprint reader (optional) |
| 13 | touch pad | 14 | touch pad buttons |
| 15 | 8-in-1 card reader | 16 | audio connectors |

- | | | | |
|----|--|----|----------------------|
| 17 | power and battery charge status lights | 18 | keyboard |
| 19 | power button | 20 | device status lights |
| 21 | display | | |

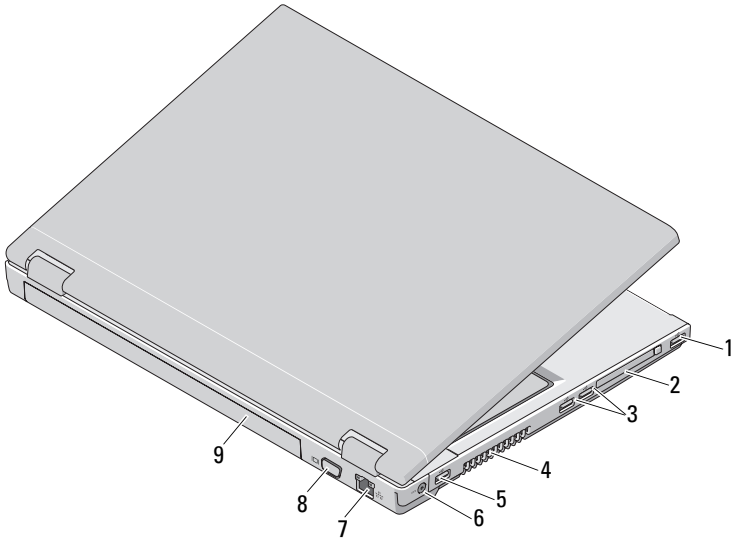





- | | | | |
|---|--------------------|---|----------------------|
| 1 | USB connector | 2 | ExpressCard/54 slot |
| 3 | USB connectors (2) | 4 | cooling vents |
| 5 | USB connector | 6 | AC Adapter connector |
| 7 | network connector | 8 | VGA connector |
| 9 | battery | | |



WARNING: Do not block, push objects into, or allow dust to accumulate in the air vents. Do not store your Dell computer in a low-airflow environment, such as a closed briefcase, while it is running. Restricting the airflow can damage the computer or cause a fire. The computer turns on the fan when the computer gets hot. Fan noise is normal and does not indicate a problem with the fan or the computer.

Quick Setup

-  **WARNING:** Before you begin any of the procedures in this section, read the safety information that shipped with your computer. For additional best practices information see www.dell.com/regulatory_compliance.
-  **WARNING:** The AC adapter works with electrical outlets worldwide. However, power connectors and power strips vary among countries. Using an incompatible cable or improperly connecting the cable to the power strip or electrical outlet may cause fire or equipment damage.
-  **CAUTION:** When you disconnect the AC adapter cable from the computer, grasp the connector, not the cable itself, and pull firmly but gently to avoid damaging the cable. When you wrap the AC adapter cable, ensure that you follow the angle of the connector on the AC adapter to avoid damaging the cable.
-  **NOTE:** Some devices may not be included if you did not order them.

1 Connect the AC adapter to the AC adapter connector on the computer and to the electrical outlet.

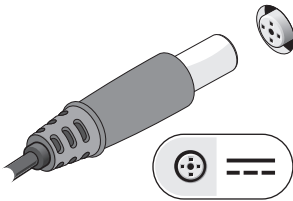

2 Connect the network cable.

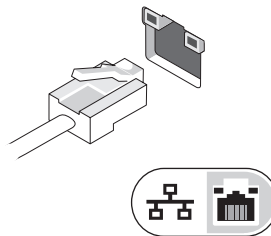

3 Connect USB devices, such as a mouse or keyboard.

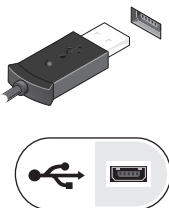

4 Connect IEEE 1394 devices, such as a DVD player.

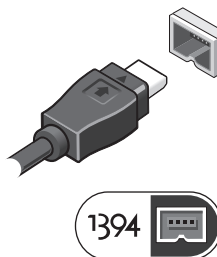

5 Open the computer display and press the power button to turn on the computer.

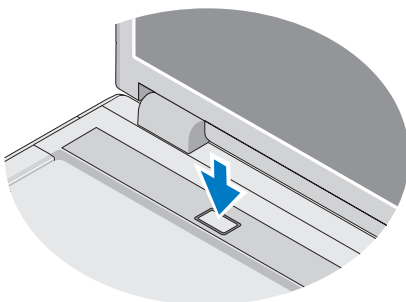

 **NOTE:** It is recommended that you turn on and shut down your computer at least once before you install any cards or connect the computer to a docking device or other external device, such as a printer.

Specifications

 **NOTE:** Offerings may vary by region. For more information regarding the configuration of your computer, click **Start**→ **Help and Support** and select the option to view information about your computer.

System Information

Processor type	Intel® Core™ 2 Duo (1.4–2.6 GHz) Intel Celeron® (1.8–2.0 GHz) Intel Celeron Dual Core (1.66 GHz–1.86 GHz)
Chipset	Integrated Intel Cantiga GM45 Integrated Intel PM45 chipset

Video

Video type	integrated on system board discrete video card
Video controller	
Integrated	Intel integrated graphics
Discrete	Vostro 1320 and 1520 — NVIDIA GeForce 9400 GS, 64 bit Vostro 1720 — NVIDIA GeForce 9600 GS, 128 bit
Video memory	
Integrated	
Total system memory less than 512 MB	up to 64 MB video memory (shared)
Total system memory greater than 512 MB	up to 256 MB video memory (shared)
Discrete	Vostro 1320 and 1520 — 256 MB (64 bit) Vostro 1720 — 512 MB (128 bit)

Battery

Type	Vostro 1320 and Vostro 1520 — 4-cell, 6-cell, and 9-cell (smart lithium) Vostro 1720 — 6-cell and 8-cell (smart lithium)
Dimensions	
Depth	
4-cell, 6-cell, and 8-cell	50.3 mm (1.98 inches)
9-cell	72.0 mm (2.835 inches)
Height	
4-cell and 6-cell	Vostro 1320 — 19.9 mm (0.783 inch)
6-cell	Vostro 1520 — 19.9 mm (0.783 inch)
6-cell and 8 cell	Vostro 1720 — 20.2 mm (0.795 inch)
9-cell	20.7 mm (0.815 inch)

Battery (continued)

Voltage	
4-cell and 8-cell	14.8 V
6-cell and 9-cell	11.1 V
Temperature range	
Operating	0° to 50° C (32° to 122° F)
Storage	-20° to 65° C (4° to 149° F)
Coin-cell battery	CR-2032

AC Adapter

Type	65 W and 90 W
Input voltage	100–240 VAC
Input current (maximum)	1.5 A
Input frequency	50–60 Hz
Output current	
65W	4.34 A (maximum at 4 second pulse) 3.34 A (continuous)
90 W	5.62 A (maximum at 4-second pulse) 4.62 A (continuous)
Rated output voltage	19.5 VDC
Temperature range	
Operating	0° to 35° C (32° to 95° F)
Storage	-40° to 60° C (-40° to 140° F)

Physical

Height	Vostro 1320 — 23.8 to 37.2 mm (0.937 to 1.465 inches) Vostro 1520 — 26.2 to 38.0 mm 1.031 to 1.496 inches) Vostro 1720 — 29.0 to 40.5 mm (1.142 to 1.594 inches)
Width	Vostro 1320 — 317.0 mm (12.480 inches) Vostro 1520 — 357.0 mm (14.055 inches) Vostro 1720 — 393.0 mm (15.472 inches)

Physical (continued)

Depth	Vostro 1320 — 243.2 mm (9.575 inches)
	Vostro 1520 — 258.0 mm (10.157 inches)
	Vostro 1720 — 286.0 mm (11.26 inches)
Weight	Vostro 1320 — minimum 2.1 kg (4.630 lbs) with a 4-cell battery
	Vostro 1520 — minimum 2.8 kg (6.173 lbs) with a 6-cell battery
	Vostro 1720 — minimum 3.41 kg (7.51 lbs) with an 8-cell battery

Environmental

Temperature range	
Operating	0° to 35° C (32° to 95° F)
Storage	-40° to 65° C (-40° to 149° F)
Relative humidity (maximum)	
Operating	10% to 90% (noncondensing)
Storage	5% to 95% (noncondensing)

Finding More Information And Resources

If you need to:	See:
Find safety best practices information for your computer, review Warranty information, Terms and Conditions(U.S only), Safety instructions, Regulatory information, Ergonomics information, and End User License Agreement.	The safety and regulatory documents that shipped with your computer and also see the Regulatory Compliance Homepage at www.dell.com/regulatory_compliance .

Information in this document is subject to change without notice.

© 2009 Dell Inc. All rights reserved.

Reproduction of these materials in any manner whatsoever without the written permission of Dell Inc. is strictly forbidden.

Trademarks used in this text: *Dell*, the *DELL* logo, and *Vostro* are trademarks of Dell Inc.; *Intel* and *Celeron* are registered trademarks and *Core* is a trademark of Intel Corporation in the U.S. and other countries.

Other trademarks and trade names may be used in this document to refer to either the entities claiming the marks and names or their products. Dell Inc. disclaims any proprietary interest in trademarks and trade names other than its own.