



# **Maintenance and Service Guide**

Compaq Presario V5000 Notebook PC

Document Part Number: 407511-002

June 2006

This guide is a troubleshooting reference used for maintaining and servicing the computer. It provides comprehensive information on identifying computer features, components, and spare parts; troubleshooting computer problems; and performing computer disassembly procedures.

© Copyright 2006 Hewlett-Packard Development Company, L.P.

Microsoft and Windows are U.S. registered trademarks of Microsoft Corporation. AMD, Sempron, Turion, and combinations thereof, are trademarks of Advanced Micro Devices, Inc. Bluetooth is a trademark owned by its proprietor and used by Hewlett-Packard Company under license. SD Logo is a trademark of its proprietor.

The information contained herein is subject to change without notice. The only warranties for HP products and services are set forth in the express warranty statements accompanying such products and services. Nothing herein should be construed as constituting an additional warranty. HP shall not be liable for technical or editorial errors or omissions contained herein.

Maintenance and Service Guide  
Compaq Presario V5000 Notebook PC  
Second Edition: June 2006  
First Edition: January 2006  
Document Part Number: 407511-002

---

# Contents

## 1 Product Description

1.1 Features . . . . .	1-2
1.2 Resetting the Computer. . . . .	1-4
1.3 Power Management. . . . .	1-5
1.4 External Components . . . . .	1-6
1.5 Design Overview. . . . .	1-20

## 2 Troubleshooting

2.1 Computer Setup. . . . .	2-1
Using Computer Setup . . . . .	2-1
Selecting from the File Menu . . . . .	2-2
Selecting from the Security Menu . . . . .	2-3
Selecting from the Diagnostics Menu . . . . .	2-4
Selecting from the System Configuration Menu. . . . .	2-5
2.2 Troubleshooting Flowcharts . . . . .	2-6

### **3 Illustrated Parts Catalog**

3.1 Serial Number Location . . . . .	3-1
3.2 Computer Major Components . . . . .	3-2
3.3 Display Assembly Subcomponents . . . . .	3-12
3.4 Plastics Kit . . . . .	3-14
3.5 Cable Kit . . . . .	3-15
3.6 Mass Storage Devices . . . . .	3-16
3.7 Miscellaneous (Not Illustrated) . . . . .	3-18
3.8 Sequential Part Number Listing . . . . .	3-20

### **4 Removal and Replacement Preliminaries**

4.1 Tools Required . . . . .	4-1
4.2 Service Considerations . . . . .	4-2
Plastic Parts . . . . .	4-2
Cables and Connectors . . . . .	4-2
4.3 Preventing Damage to Removable Drives . . . . .	4-3
4.4 Preventing Electrostatic Damage . . . . .	4-4
4.5 Packaging and Transporting Precautions . . . . .	4-5
4.6 Workstation Precautions . . . . .	4-6
4.7 Grounding Equipment and Methods . . . . .	4-7

---

## 5 Removal and Replacement Procedures

5.1	Serial Number	5-2
5.2	Disassembly Sequence Chart	5-3
5.3	Preparing the Computer for Disassembly	5-5
5.4	Hard Drive	5-7
5.5	Computer Feet	5-11
5.6	Memory Module	5-12
5.7	Mini PCI Communications Module	5-16
5.8	RTC Battery	5-18
5.9	Optical Drive	5-19
5.10	Switch Cover	5-22
5.11	Keyboard	5-24
5.12	Display Assembly	5-27
5.13	Base Enclosure	5-41
5.14	Bluetooth Module	5-46
5.15	System Board	5-48
5.16	Display Release Button	5-56
5.17	LED Board	5-60
5.18	Heat Sink	5-62
5.19	Processor	5-65
5.20	Fan Assembly	5-69
5.21	PC Card Assembly	5-73
5.22	ExpressCard Assembly	5-76

**6 Specifications**

**A Screw Listing**

**B Software Update and Recovery**

**C Display Component Recycling**

**D Connector Pin Assignments**

**E Power Cord Set Requirements**

**Index**

# 1

---

## Product Description

The Compaq Presario V5000 Notebook PC offers advanced modularity, Mobile AMD Sempron™ and AMD Turion™ 64 Mobile Technology processors, and extensive multimedia support.



*Compaq Presario V5000 Notebook PC*

## 1.1 Features

---



Numerous references are made throughout this *Maintenance and Service Guide* to “full-featured” and “defeatured” computer models. A model is considered to be full-featured if it has 3 Universal Serial Bus ports and the following components:

- PC Card slot
- IEEE 1394 port
- Memory Reader

A model is considered to be defeatured if it has only 2 Universal Serial Bus ports and none of the components listed above.

---

- AMD Turion 64 ML-40 (2.2-GHz), ML-37 (2.0-GHz), ML-34 (1.8-GHz), ML-32 (1.8-GHz) processors, all with 1-GB L2 cache, or Mobile AMD Sempron M3300 (2.0-GHz) or M3000 (1.8-GHz) processors with 512-MB L2 cache, varying by computer model
- 15.4-inch, WXGA, TFT (1280 × 800) display with antiglare or BrightView, varying by computer model
- 120-, 100-, 80-, 60-, or 40-GB high-capacity hard drive, varying by computer model
- 256-MB DDR1 synchronous DRAM (SDRAM) at 333 MHz, expandable to 2.0 GB
- Microsoft® Windows® XP Home Edition or Windows XP Professional, varying by computer model
- Full-size Windows keyboard with embedded numeric keypad



- TouchPad pointing device, including dedicated horizontal and vertical scroll regions
- Integrated 10Base-T/100Base-TX Ethernet local area network (LAN) network interface card (NIC) with RJ-45 jack
- Integrated high-speed 56K modem with RJ-11 jack
- Integrated wireless support for Mini PCI IEEE 802.11a/b/g WLAN device
- Support for one Type I or Type II PC Card slot, with support for both 32-bit (CardBus) and 16-bit PC Cards
- Support for ExpressCard slot
- External 65-watt AC adapter with 3-wire power cord
- 12- or 6-cell Li-Ion battery
- Stereo speakers
- Volume up, volume mute, and volume down buttons
- Support for the following optical drives:
  - DVD±RW and CD-RW Super Multi Double-Layer Combo Drive
  - DVD±RW and CD-RW Double-Layer Combo Drive
  - DVD/CD-RW Super Multi Double-Layer Combo Drive with LightScribe and Hitachi LG Data Storage
  - DVD/CD-RW Double-Layer Combo Drive with LightScribe
  - DVD/CD-RW Combo Drive

- Connectors:
  - ❑ Audio-in (microphone)
  - ❑ Audio-out (headphone)
  - ❑ Memory Reader (select models only)
  - ❑ Expansion port 2
  - ❑ ExpressCard slot
  - ❑ External monitor
  - ❑ IEEE 1394 (select models only)
  - ❑ PC Card (select models only)
  - ❑ Power
  - ❑ RJ-11 (modem)
  - ❑ RJ-45 (network)
  - ❑ S-Video-out
  - ❑ Universal Serial Bus (USB) v. 2.0 (2 or 3 ports, varying by computer model)

## 1.2 Resetting the Computer

If the computer you are servicing has an unknown password, follow these steps to clear the password. These steps also clear CMOS:

1. Prepare the computer for disassembly (refer to [Section 5.3, “Preparing the Computer for Disassembly,”](#) for more information.)
2. Remove the real-time clock (RTC) battery (refer to [Section 5.8, “RTC Battery,”](#) for more information.)

3. Wait approximately 5 minutes.
4. Replace the RTC battery and reassemble the computer.
5. Connect AC power to the computer. Do not reinsert any batteries at this time.
6. Turn on the computer.

All passwords and CMOS settings have been cleared.

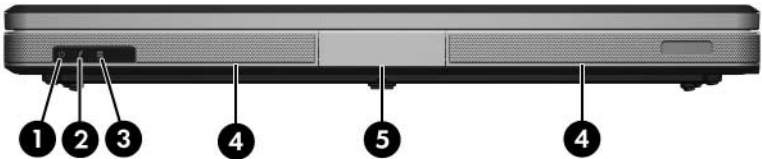
## 1.3 Power Management

The computer comes with power management features that extend battery operating time and conserve power. The computer supports the following power management features:

- Standby
- Hibernation
- Setting customization by the user
- Hotkeys for setting the level of performance
- Battery calibration
- Lid switch standby/resume
- Power button
- Advanced Configuration and Power Management (ACPM) compliance

## 1.4 External Components

The external components on the front of the computer are shown below and described in Table 1-1.

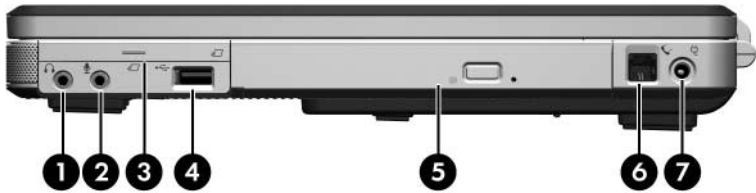


*Front Components*

**Table 1-1**  
**Front Components**

Item	Component	Function
1	Power light	<ul style="list-style-type: none"> <li>■ On: Computer is turned on.</li> <li>■ Off: Computer is off or in hibernation.</li> <li>■ Blinking: Computer is in standby.</li> </ul>
2	Battery light	<ul style="list-style-type: none"> <li>■ On: A battery is charging or is close to full charge capacity.</li> <li>■ Off: If the computer is plugged into an external power source, the light is turned off when all batteries in the computer are fully charged. If the computer is not plugged into an external power source, the light stays off until the battery reaches a low-battery condition.</li> <li>■ Blinking: A battery that is the only available power source has reached a low-battery condition. When the battery reaches a critical low-battery condition, the battery light begins blinking quickly.</li> </ul>
3	Drive light	On or blinking: The internal hard drive or an optical drive is being accessed.
4	Speakers	Produce stereo sound.
5	Display release button	Opens the computer.

The external components on the right side of the computer are shown below and described in Table 1-2.



*Right-Side Components*

---

**Table 1-2**

**Right-Side Components**

<b>Item</b>	<b>Component</b>	<b>Function</b>
1	Audio-out (headphone) jack	Connects an optional headphone or powered stereo speakers. Also connects the audio function of an audio/video device, such as a television or VCR.
2	Audio-in (microphone) jack	Connects an optional stereo microphone.
3	ExpressCard slot	Supports an optional ExpressCard.
4	USB port (select models only)	Connects optional USB devices.
5	Optical drive	Supports an optical disc, such as a CD or DVD.
6	RJ-11 (modem) jack	Connects a modem cable (not included).
7	Power connector	Connects the AC adapter cable.

---

The external components on the rear panel of the computer are shown below and described in Table 1-3.

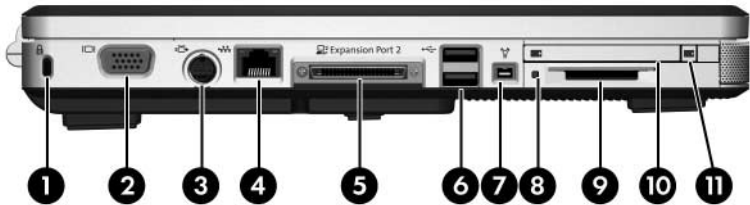


*Rear Panel Components*

**Table 1-3**  
**Rear Panel Components**

<b>Item</b>	<b>Component</b>	<b>Function</b>
1	Battery bay	Holds a battery.
2	Vent	<p>Provides airflow to cool internal components.</p> <p>△ To prevent overheating, do not obstruct vents. Do not allow a hard surface, such as a printer, or a soft surface, such as pillows or thick rugs or clothing, to block airflow.</p>

The external components on the left side of the computer are shown below and described in Table 1-4.




*Left-Side Components*

---

**Table 1-4**


**Left-Side Components**

Item	Component	Function
1	Security cable slot	Attaches an optional security cable to the computer.   The purpose of security solutions is to act as a deterrent. These solutions do not prevent the product from being mishandled or stolen.
2	Monitor port	Connects an optional VGA monitor or projector.
3	S-Video-out jack	Connects the video function of an optional S-Video device, such as a television, VCR, or video capture card.

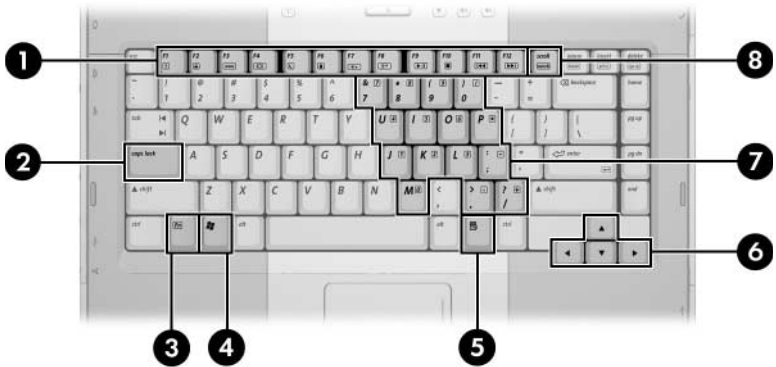
---



**Table 1-4**  
**Left-Side Components (Continued)**

Item	Component	Function
4	RJ-45 (network) jack	Connects a network cable (not included).
5	Expansion port 2	Connects the computer to an optional docking device.   The computer has only one expansion port. The term <i>expansion port 2</i> describes the type of expansion port.
6	USB ports (2)	Connect optional USB devices.
7	1394 port (select models only)	Connects an optional 1394a device such as a scanner, a digital camera, or a digital camcorder.
8	Memory Reader light (select models only)	On: An optional digital card is being accessed.
9	Memory Reader (select models only)	Supports the following optional digital cards: SD (Secure Digital) Memory Card, SD I/O Card, Memory Stick, Memory Stick Pro, MultiMediaCard, xD-Picture Card, and SmartMedia.
10	PC Card slot (select models only)	Supports an optional Type I or Type II 32-bit (CardBus) or 16-bit PC Card.
11	PC Card eject button (select models only)	Ejects PC Cards from the PC Card slot.

The standard keyboard components of the computer are shown below and described in Table 1-5.



*Standard Keyboard Components*

**Table 1-5**  
**Standard Keyboard Components**


<b>Item</b>	<b>Component</b>	<b>Function</b>
1	<b>F1 to F12</b> keys (12)	Perform system and application tasks. When combined with <b>Fn</b> , function keys perform additional tasks as hotkeys.
2	<b>caps lock</b> key	Enables caps lock and turns on the caps lock light.
3	<b>Fn</b> key	Combines with other keys to perform system tasks as hotkeys. For example, pressing <b>Fn+f7</b> decreases screen brightness.
4	Windows logo key	Displays the Microsoft Windows Start menu.
5	Windows applications key	Displays a shortcut menu for items beneath the pointer.
6	Arrow keys	Move the cursor around the screen.
7	Numeric keypad keys (15)	Can be used like the keys on an external numeric keypad.
8	<b>num lock</b> key	Enables numeric lock, turns on the embedded numeric keypad, and turns on the num lock light.

The computer top components are shown below and described in Table 1-6.

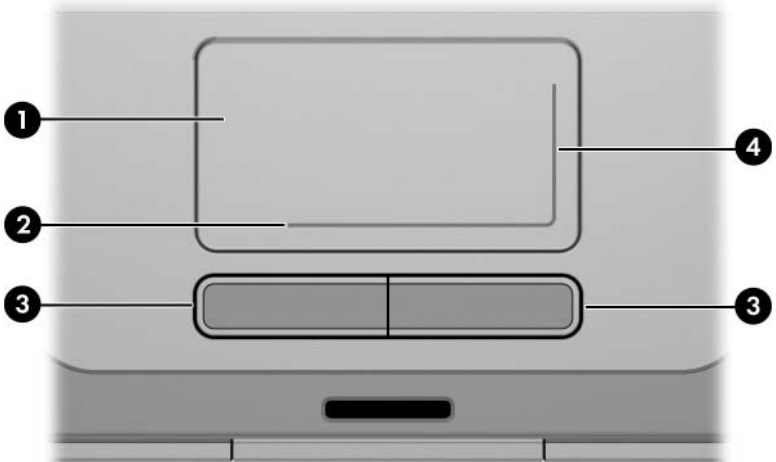


Top Components

**Table 1-6**  
**Top Components**

Item	Component	Function
1	caps lock light	On: Caps lock is enabled.
2	Wireless button	<p>Turns the wireless functionality on or off, but does not create a wireless connection.</p> <p> To establish a wireless connection, a wireless network must already be set up.</p>
3	Power button	<p>When the computer is</p> <ul style="list-style-type: none"> <li>■ Off, press to turn on the computer.</li> <li>■ On, press to enter hibernation.</li> <li>■ In standby, briefly press to exit standby.</li> <li>■ In hibernation, briefly press to exit hibernation.</li> </ul> <p>If the computer has stopped responding and Microsoft® Windows® shutdown procedures cannot be used, press and hold the power button for at least 5 seconds to turn off the computer.</p>
4	Volume down button	Decreases system volume.
5	Volume up button	Increases system volume.
6	Volume mute button	Mutes or restores volume.
7	num lock light	On: Num lock is enabled.

The computer TouchPad components are shown below and described in Table 1-7.



*TouchPad Components*

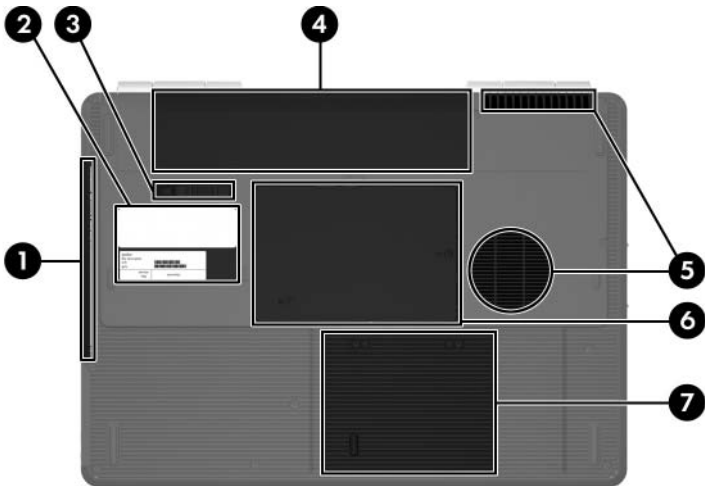
---

**Table 1-7**  
**TouchPad Components**

<b>Item</b>	<b>Component</b>	<b>Function</b>
1	TouchPad	Moves the pointer and selects or activates items on the screen. Can be set to perform other mouse functions, such as scrolling, selecting, and double-clicking.
2	TouchPad horizontal scroll zone	Scrolls left or right.
3	Left and right TouchPad buttons	Function like the left and right buttons on an external mouse.
4	TouchPad vertical scroll zone	Scrolls up or down.

---

The external components on the bottom of the computer are shown below and described in Table 1-8.



*Bottom Components*

---

**Table 1-8**  
**Bottom Components**

Item	Component	Function
1	Optical drive	Supports an optical disc, such as a CD or DVD.
2	Labels area	Contains the serial number and other information labels.
3	Battery release latch	Releases a battery from the battery bay.
4	Battery bay	Holds a battery.

---



**Table 1-8**  
**Bottom Components (*Continued*)**

Item	Component	Function
5	Vents (2)	<p>Provide airflow to cool internal components.</p> <p>△ To prevent overheating, do not obstruct vents. Do not allow a hard surface, such as a printer, or a soft surface, such as pillows or thick rugs or clothing, to block airflow.</p>
6	Memory/Mini PCI module compartment cover	<p>■ Contains 2 memory module slots that support replaceable memory modules. The number of preinstalled memory modules varies by computer model.</p> <p>■ Holds an optional wireless LAN device (select models only).</p> <p>△ To prevent an unresponsive system and the display of a warning message, install only a Mini PCI device authorized for use in your computer by the governmental agency that regulates wireless devices in your country. If you install an unauthorized device and then receive a warning message, remove the device to restore computer functionality. Then contact Customer Care.</p>
7	Hard drive bay	Holds the internal hard drive.

## 1.5 Design Overview

This section presents a design overview of key parts and features of the computer. Refer to [Chapter 3, “Illustrated Parts Catalog,”](#) to identify replacement parts, and [Chapter 5, “Removal and Replacement Procedures,”](#) for disassembly steps.

The system board provides the following device connections:

- Mobile AMD Sempron and AMD Turion 64 processors
- Audio
- Digital media card
- Display
- ExpressCard
- Hard drive
- Keyboard
- Memory module
- Mini PCI communications devices
- PC Card
- TouchPad



**CAUTION:** To properly ventilate the computer, allow at least a 7.6-cm (3-inch) clearance on the left and right sides of the computer.

---

The computer uses an electric fan for ventilation. The fan is controlled by a temperature sensor and is designed to turn on automatically when high temperature conditions exist. These conditions are affected by high external temperatures, system power consumption, power management/battery conservation configurations, battery fast charging, and software. Exhaust air is displaced through the ventilation grill located on the left side of the computer.

---

# Troubleshooting

---



**WARNING:** Only authorized technicians trained by HP should repair this equipment. All troubleshooting and repair procedures are detailed to allow only subassembly-/module-level repair. Because of the complexity of the individual boards and subassemblies, do not attempt to make repairs at the component level or modifications to any printed wiring board. Improper repairs can create a safety hazard. Any indication of component replacement or printed wiring board modification may void any warranty or exchange allowances.

---

## 2.1 Computer Setup

Computer Setup is a system information and customization utility that can be used even when the operating system is not working or will not load. This utility includes settings that are not available in Windows.

### Using Computer Setup

Information and settings in Computer Setup are accessed from the File, Security, Diagnostics, or System Configuration menus:

1. Turn on or restart the computer. Press **f10** while the F10 = ROM-Based Setup message is displayed in the lower-left corner of the screen.
  - ❑ To change the language, use the cursor control keys to navigate to the **System Configuration** menu.
  - ❑ To view navigation information, press **f1**.
  - ❑ To return to the Computer Setup menu, press **esc**.

2. Select the **File, Security, Diagnostics, or System Configuration** menu.
3. To close Computer Setup and restart the computer:
  - ❑ Select **File > Save changes and exit**, and then press **enter**.
  - or –
  - ❑ Select **File > Ignore changes and exit**, and then press **enter**.
  - or –
  - ❑ Select **File > Restore defaults**, and then press **enter**.
4. When you are prompted to confirm your action, press **f10**.

## Selecting from the File Menu

---



**Table 2-1**  
**File Menu**

Select	To Do This
System Information	<ul style="list-style-type: none"><li>■ View identification information about the computer, processor, memory and cache size, and system ROM.</li><li>■ View BIOS revision, keyboard controller version, and battery pack serial number information.</li></ul>

---

## Selecting from the Security Menu

**Table 2-2**  
**Security Menu**

Select	To Do This
Setup Password	Enter, change, or delete an Setup password.
Power-On Password	Enter, change, or delete a power-on password.
Password Options (Password options can be selected only when a power-on password has been set.)	Enable/disable: <ul style="list-style-type: none"> <li>■ Stringent security.</li> <li>■ Requirement of password on restart.</li> </ul>
DriveLock Passwords	Enable/disable DriveLock; change a DriveLock user or master password.   DriveLock Settings are accessible only when you enter Computer Setup by turning on (not restarting) the computer.
Smart Card Security	Enable/disable smart card power-on support.   A setup password must be established to use this feature.
TPM Embedded Security	Enable/disable: <ul style="list-style-type: none"> <li>■ Embedded security device state.</li> <li>■ Power-on authentication support.</li> <li>■ Automatic DriveLock support.</li> </ul>
System IDs	Establish: <ul style="list-style-type: none"> <li>■ Notebook asset tracking number.</li> <li>■ Notebook ownership tags.</li> </ul>
Disk Sanitizer	Establish fast, optimum, or custom settings for disk sanitizing.

\*Not applicable to SuperDisk LS-120 drives.

## Selecting from the Diagnostics Menu

---

**Table 2-3**  
**Diagnostics Menu**

<b>Select</b>	<b>To Do This</b>
HDD Self-Test Options	Run a quick comprehensive self test on hard drives in the system that support the test features.
Memory Check	Run a quick comprehensive test on system memory on the following categories: <ul style="list-style-type: none"><li>■ Walking 0s</li><li>■ Walking 1s</li><li>■ High Address line testing</li><li>■ Alternate Pattern testing</li></ul>

---

# Selecting from the System Configuration Menu

**Table 2-4**  
**System Configuration Menu**

Select	To Do This
Language	Change the Computer Setup language.
Boot Options	Enable/disable MultiBoot, which sets a startup sequence that can include most bootable devices and media in the system.
Device Configurations	Enable/disable: <ul style="list-style-type: none"> <li>■ Swap <b>Fn/Ctrl</b> keys.</li> <li>■ USB legacy support.</li> <li>■ BIOS DMA data transfers.</li> <li>■ Fan Always on while on AC Power.</li> <li>■ Data Execution Prevention.</li> <li>■ LAN Power save.</li> </ul>
Built-In Device Options	Enable/disable: <ul style="list-style-type: none"> <li>■ Embedded WLAN Device Radio.</li> <li>■ Embedded Bluetooth Device Radio.</li> <li>■ LAN/WLAN Switching.</li> <li>■ Wake on LAN from Off.</li> </ul>
Port Options	Enable/disable: <ul style="list-style-type: none"> <li>■ USB Port.</li> <li>■ 1394 Port.</li> <li>■ CardBus Slot.</li> </ul>

## 2.2 Troubleshooting Flowcharts

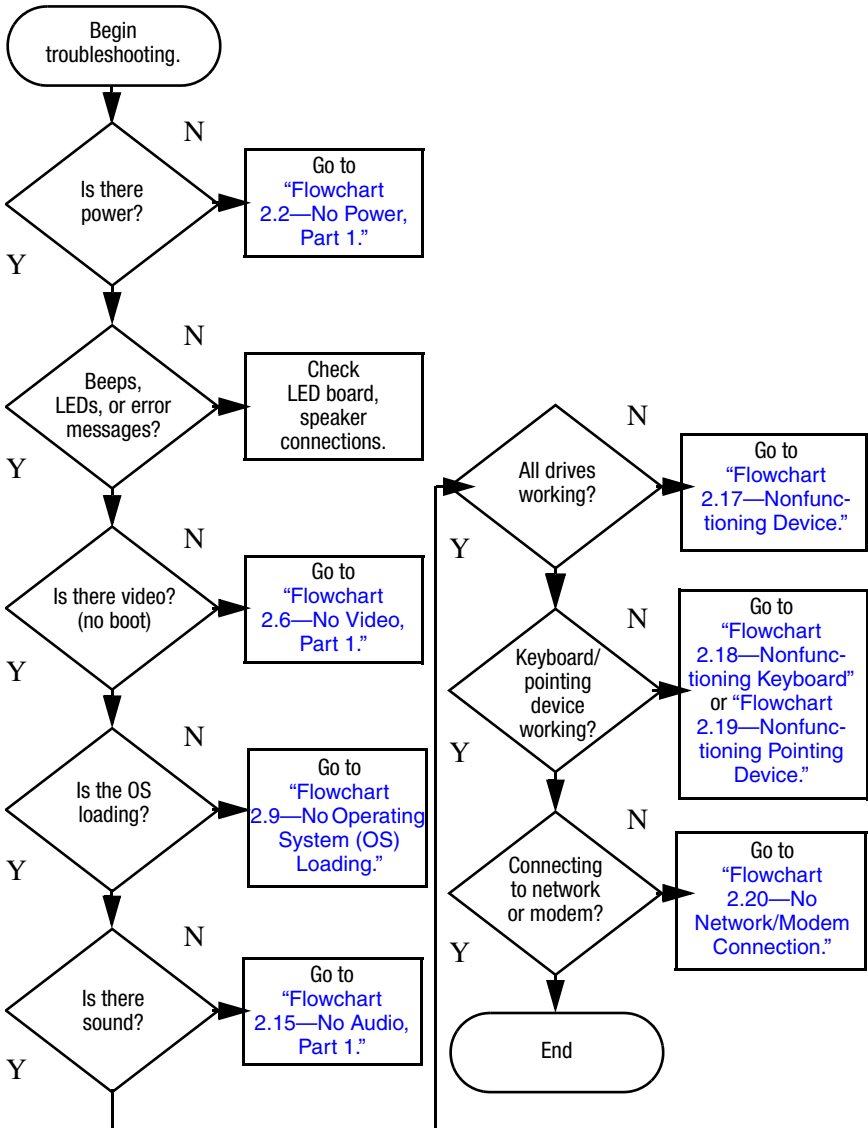
---

**Table 2-5**  
**Troubleshooting Flowcharts Overview**

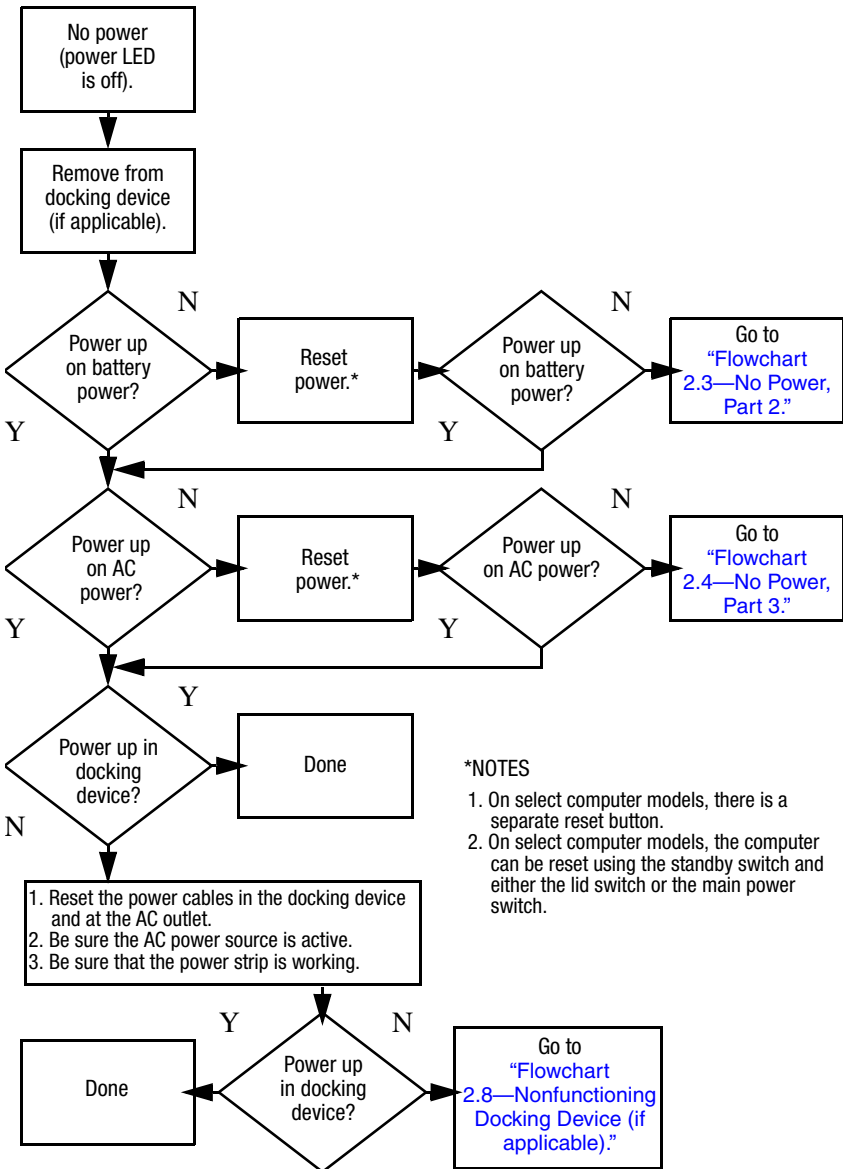
<b>Flowchart</b>	<b>Description</b>
2.1	"Flowchart 2.1—Initial Troubleshooting"
2.2	"Flowchart 2.2—No Power, Part 1"
2.3	"Flowchart 2.3—No Power, Part 2"
2.4	"Flowchart 2.4—No Power, Part 3"
2.5	"Flowchart 2.5—No Power, Part 4"
2.6	"Flowchart 2.6—No Video, Part 1"
2.7	"Flowchart 2.7—No Video, Part 2"
2.8	"Flowchart 2.8—Nonfunctioning Docking Device (if applicable)"
2.9	"Flowchart 2.9—No Operating System (OS) Loading"
2.10	"Flowchart 2.10—No OS Loading, Hard Drive, Part 1"
2.11	"Flowchart 2.11—No OS Loading, Hard Drive, Part 2"
2.12	"Flowchart 2.12—No OS Loading, Hard Drive, Part 3"
2.13	"Flowchart 2.13—No OS Loading, Diskette Drive"
2.14	"Flowchart 2.14—No OS Loading, Optical Drive"
2.15	"Flowchart 2.15—No Audio, Part 1"
2.16	"Flowchart 2.16—No Audio, Part 2"
2.17	"Flowchart 2.17—Nonfunctioning Device"
2.18	"Flowchart 2.18—Nonfunctioning Keyboard"
2.19	"Flowchart 2.19—Nonfunctioning Pointing Device"
2.20	"Flowchart 2.20—No Network/Modem Connection"



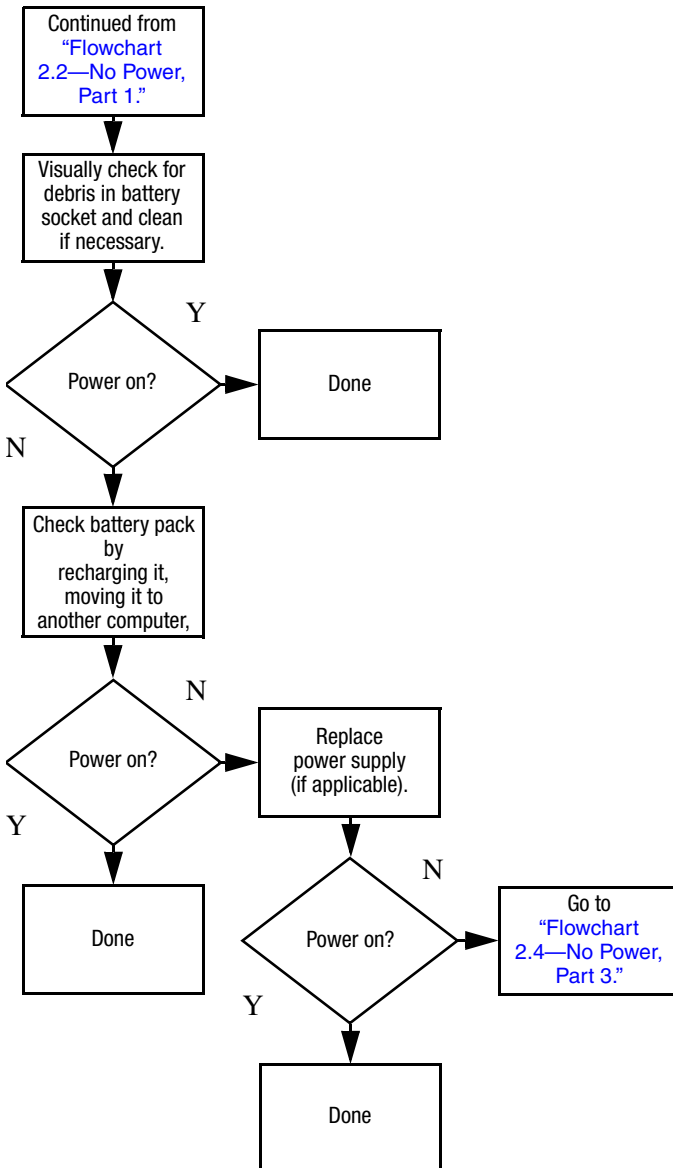
## Flowchart 2.1 – Initial Troubleshooting



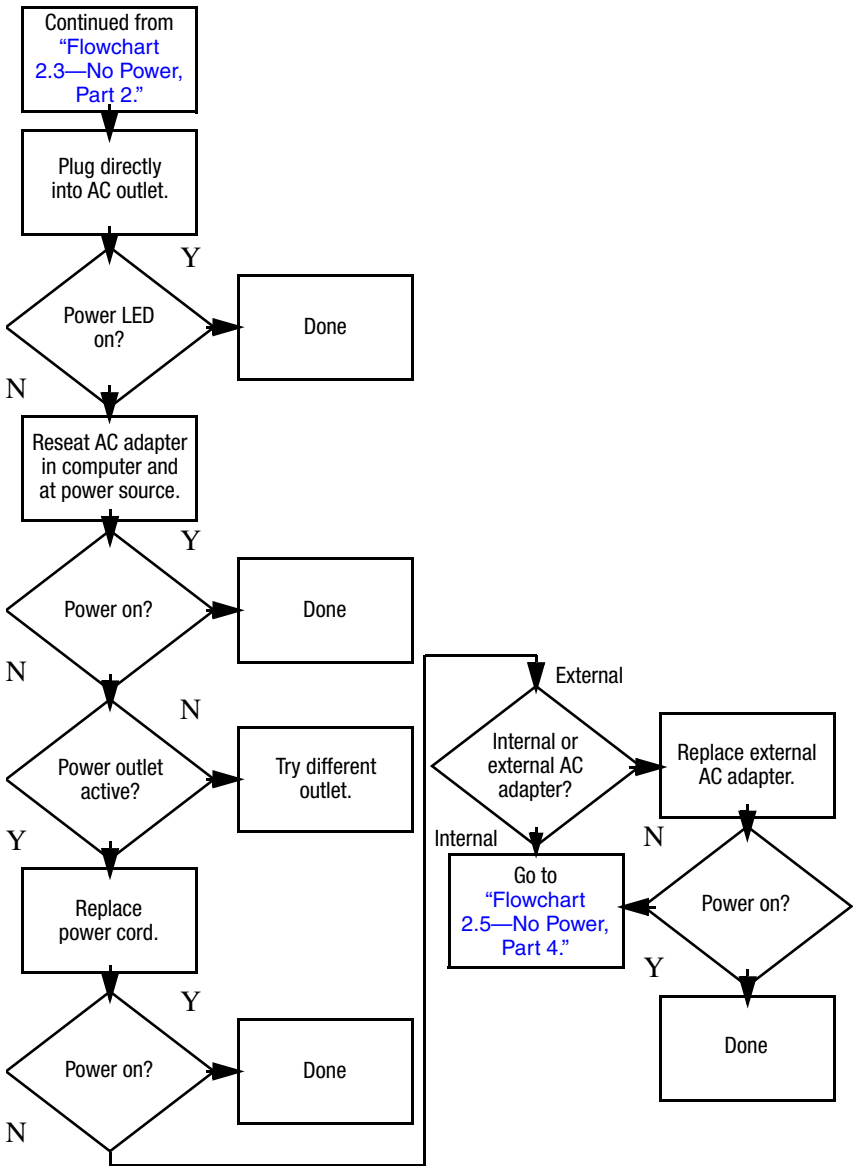
## Flowchart 2.2—No Power, Part 1



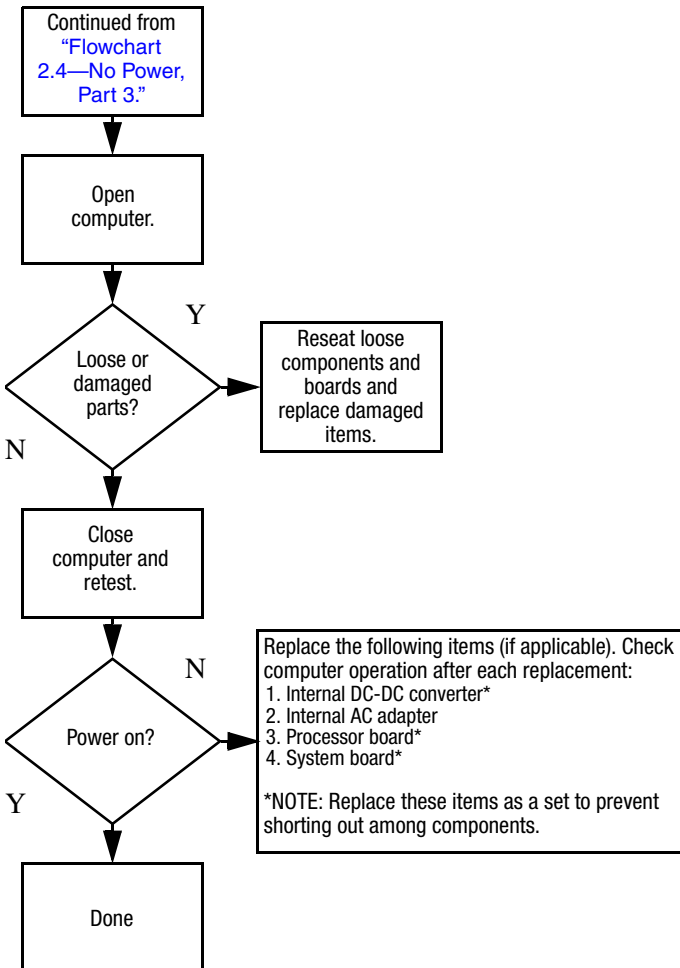
## Flowchart 2.3—No Power, Part 2



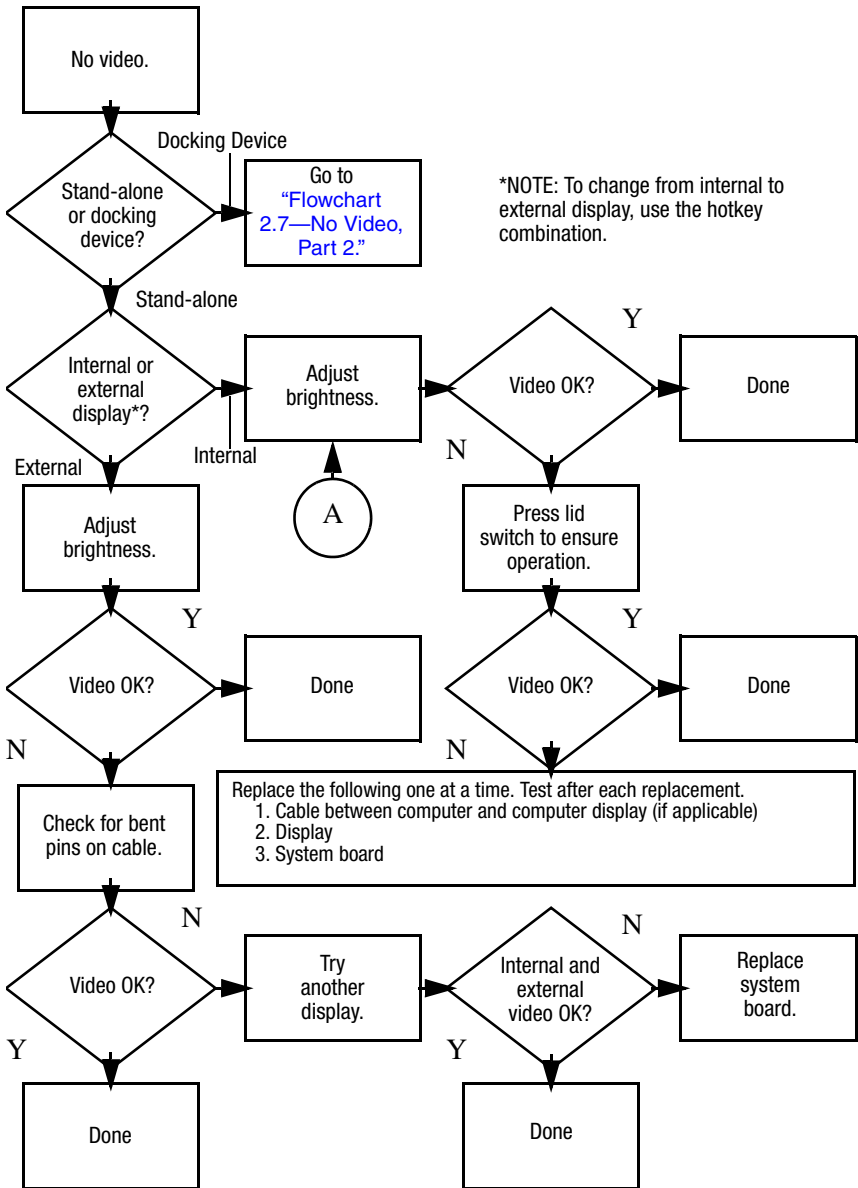
### Flowchart 2.4—No Power, Part 3



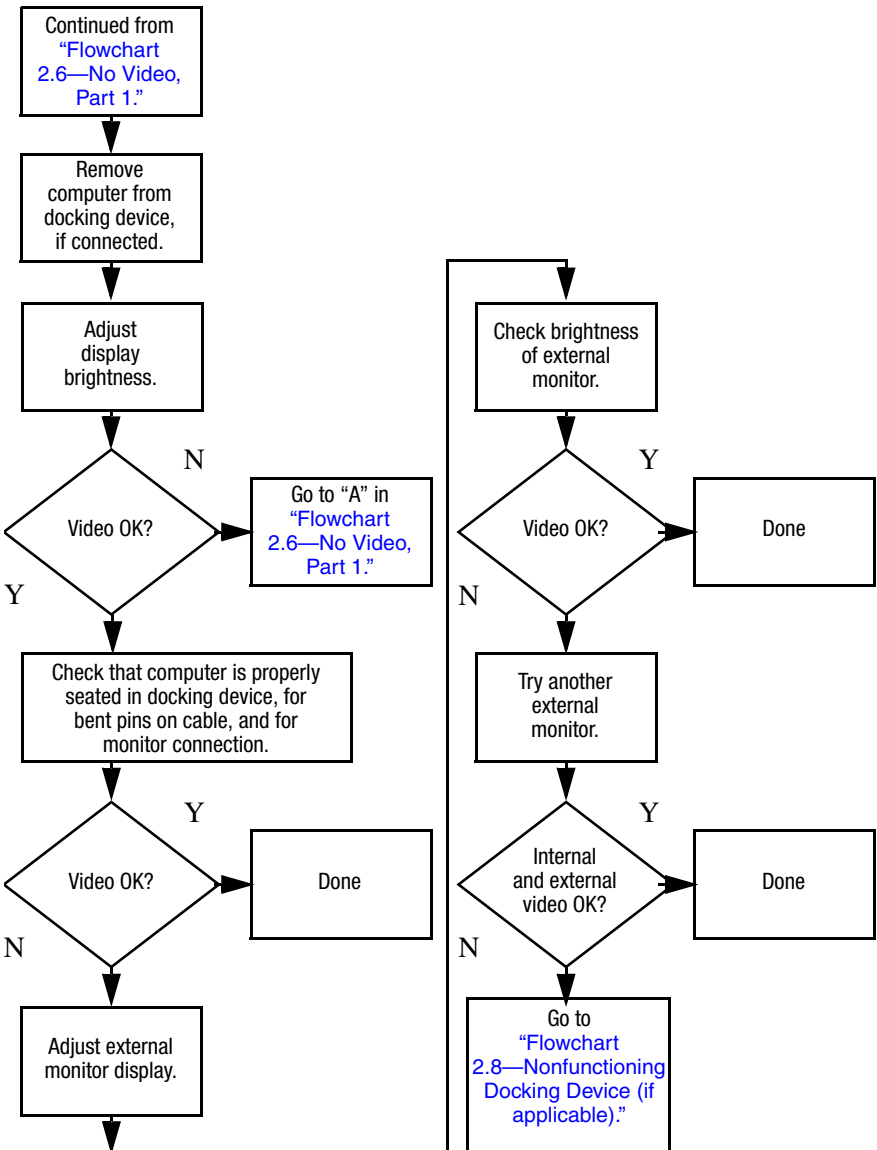
## Flowchart 2.5—No Power, Part 4



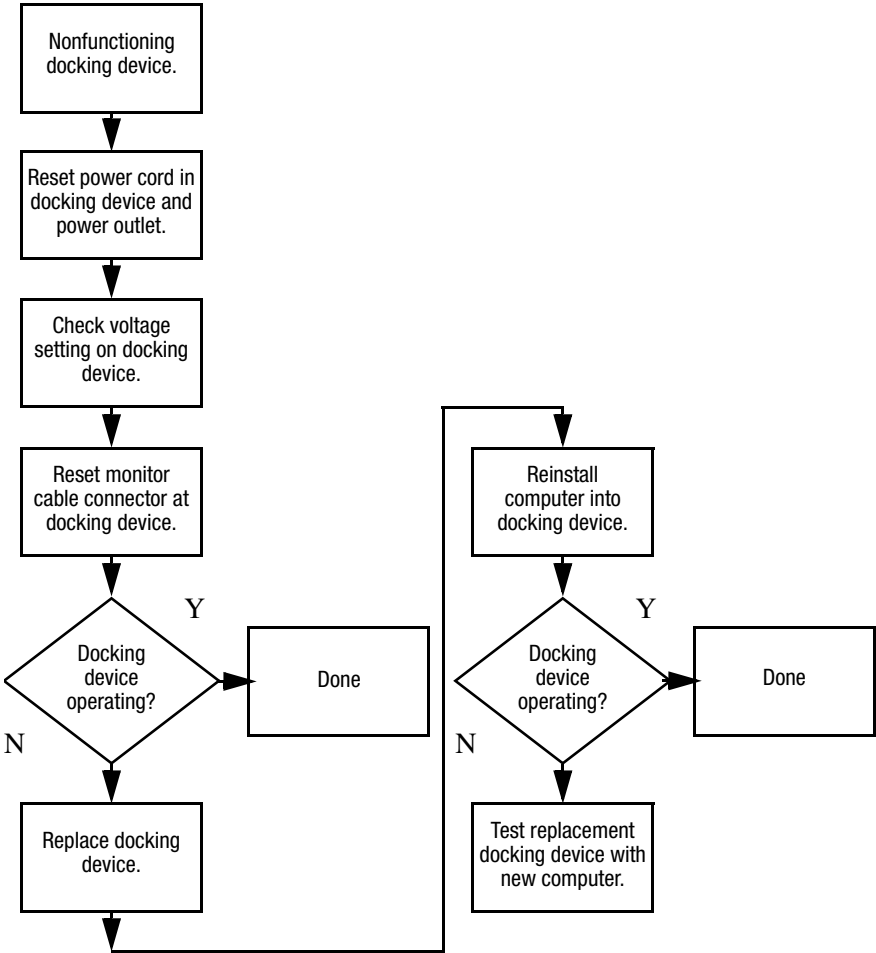
## Flowchart 2.6—No Video, Part 1



## Flowchart 2.7—No Video, Part 2

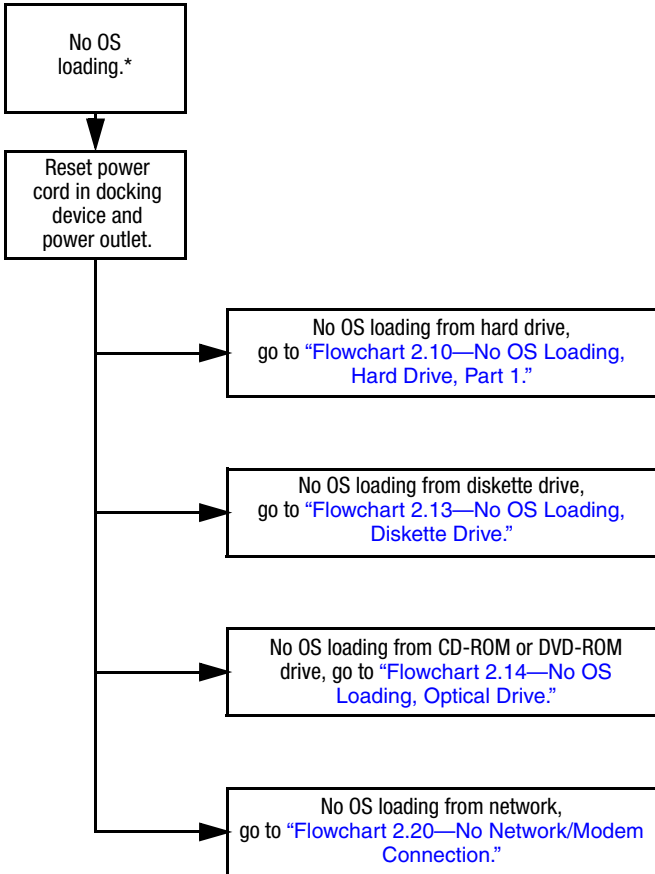


## Flowchart 2.8—Nonfunctioning Docking Device (if applicable)



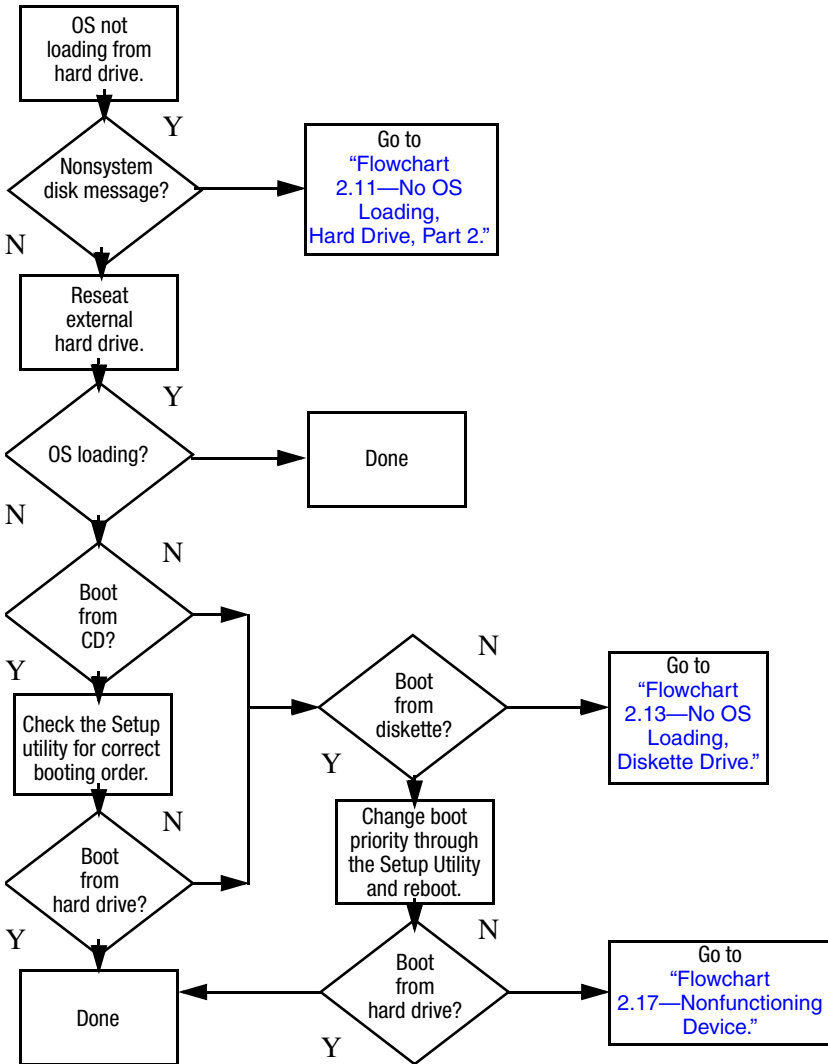


## Flowchart 2.9—No Operating System (OS) Loading

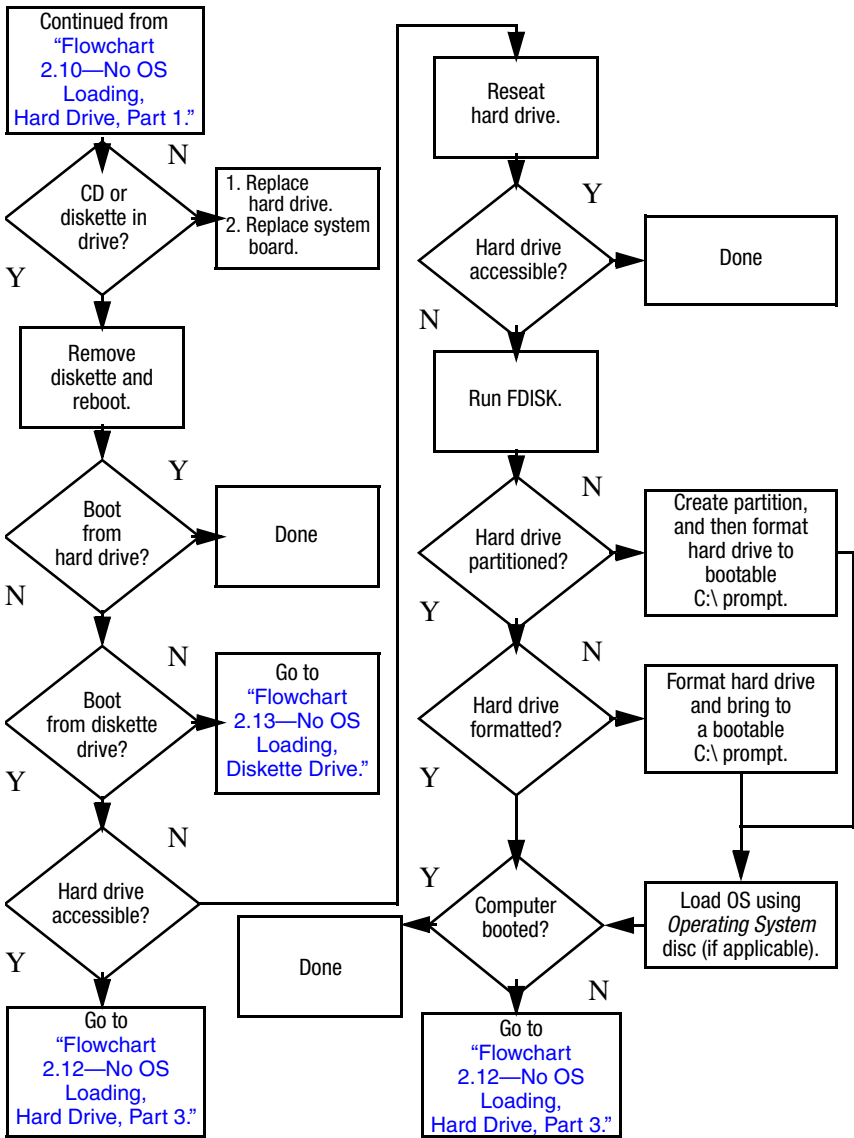


\*NOTE: Before beginning troubleshooting, always check cable connections, cable ends, and drives for bent or damaged pins.

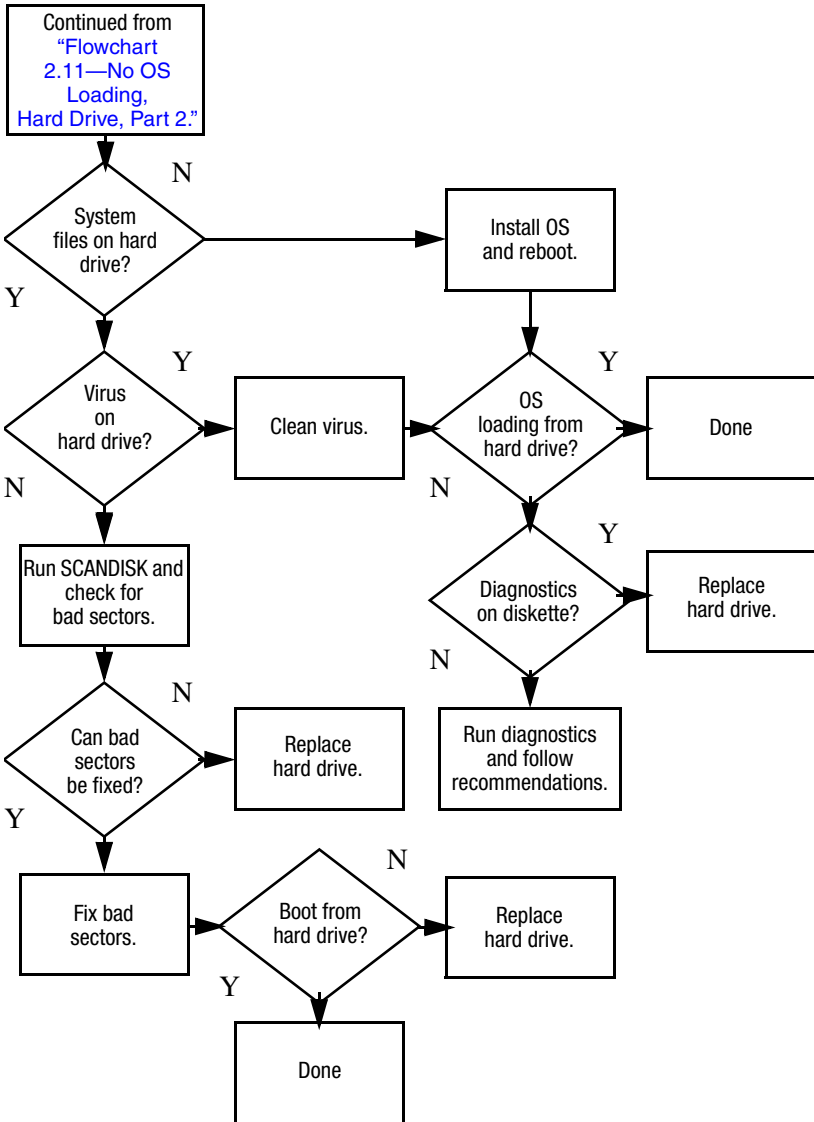
## Flowchart 2.10—No OS Loading, Hard Drive, Part 1



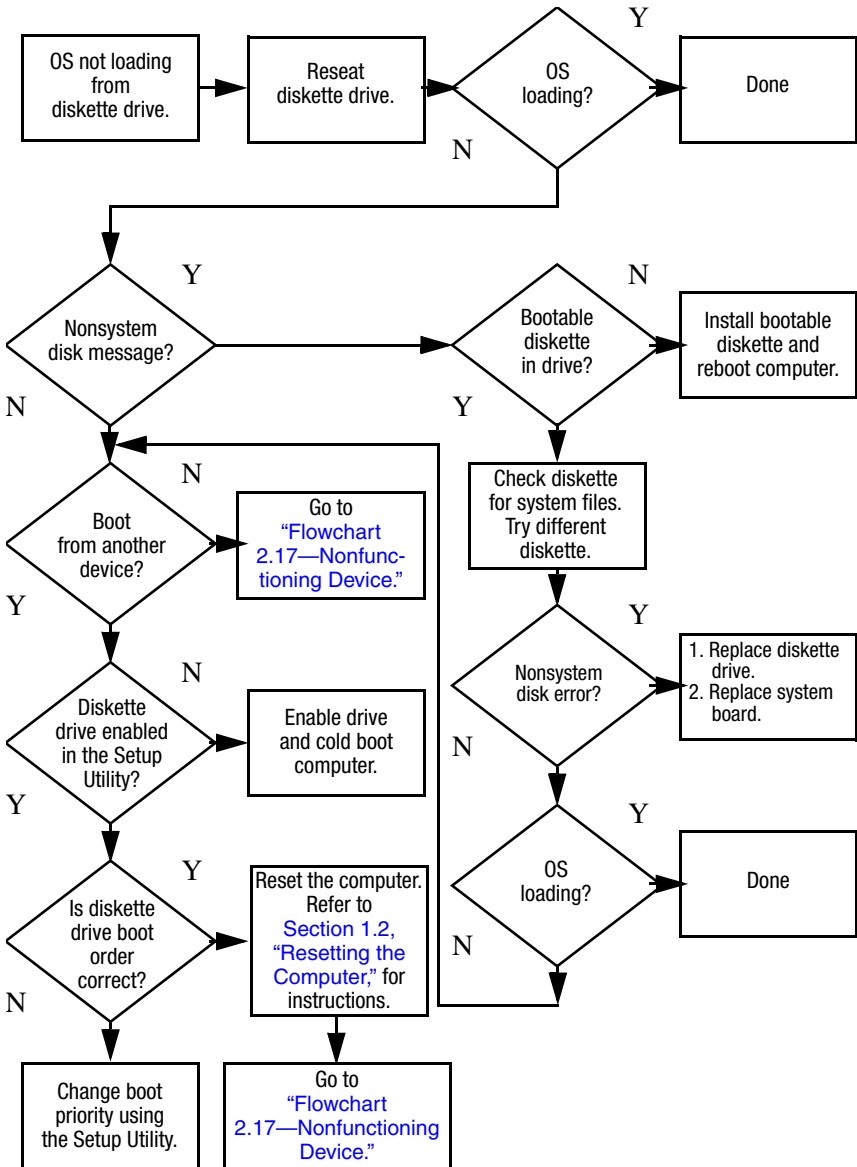
## Flowchart 2.11 – No OS Loading, Hard Drive, Part 2



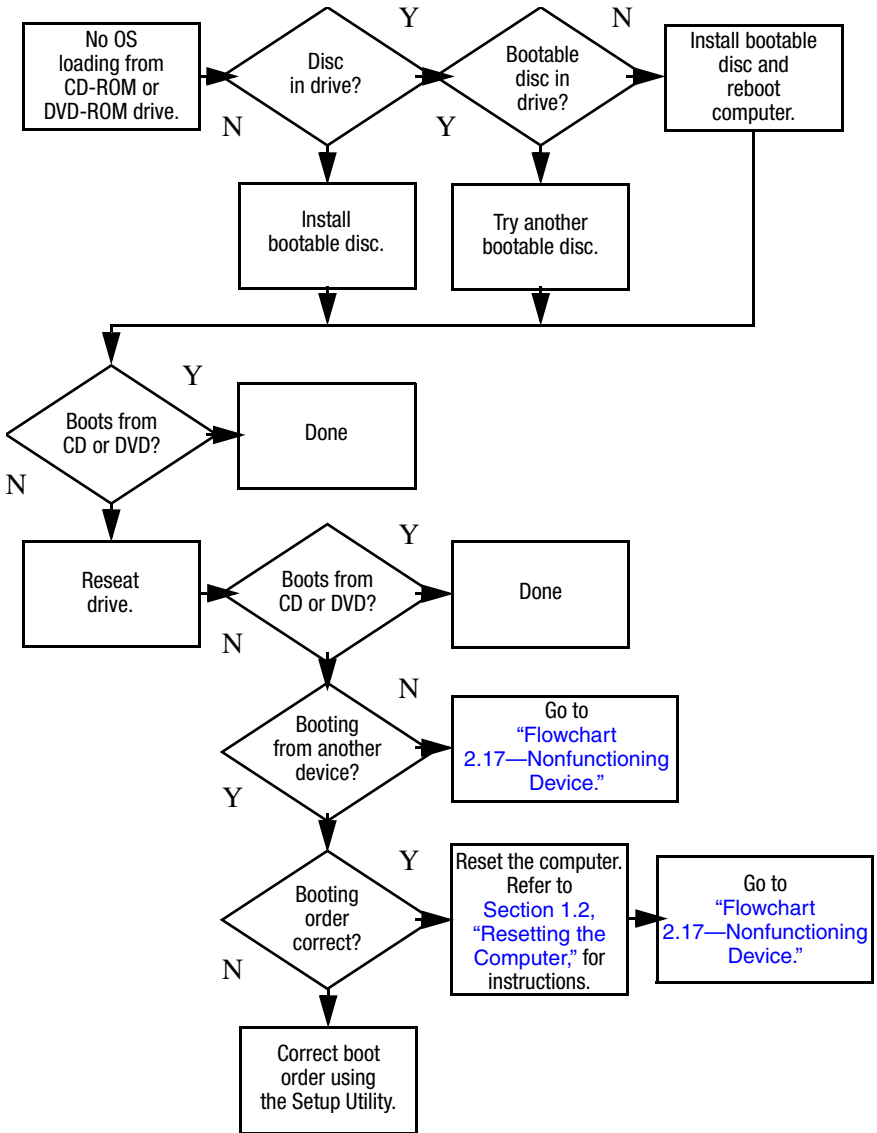
## Flowchart 2.12—No OS Loading, Hard Drive, Part 3



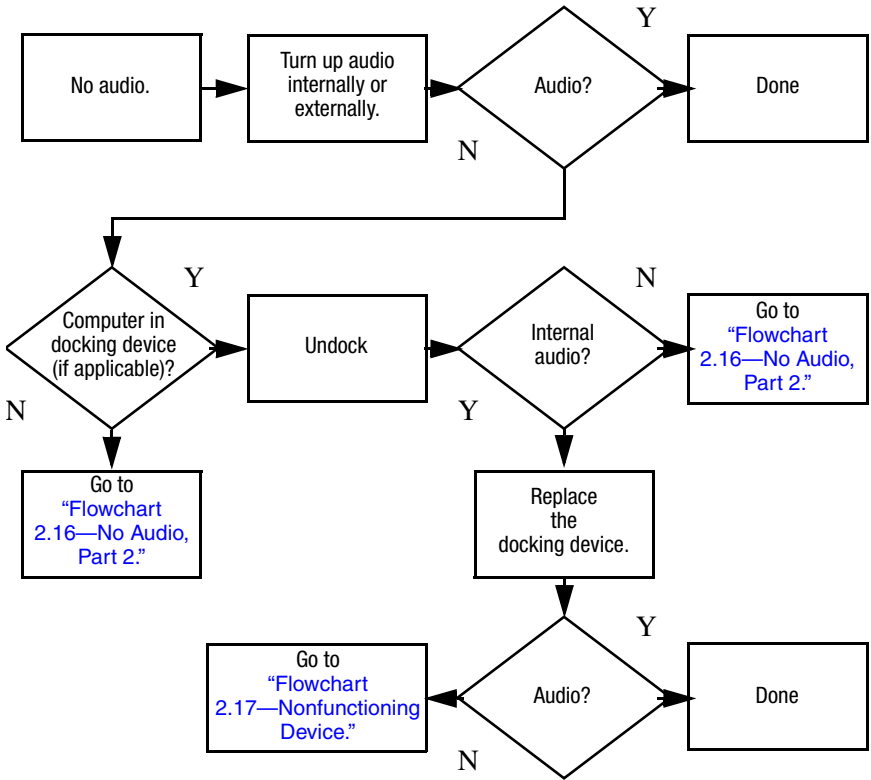
## Flowchart 2.13—No OS Loading, Diskette Drive



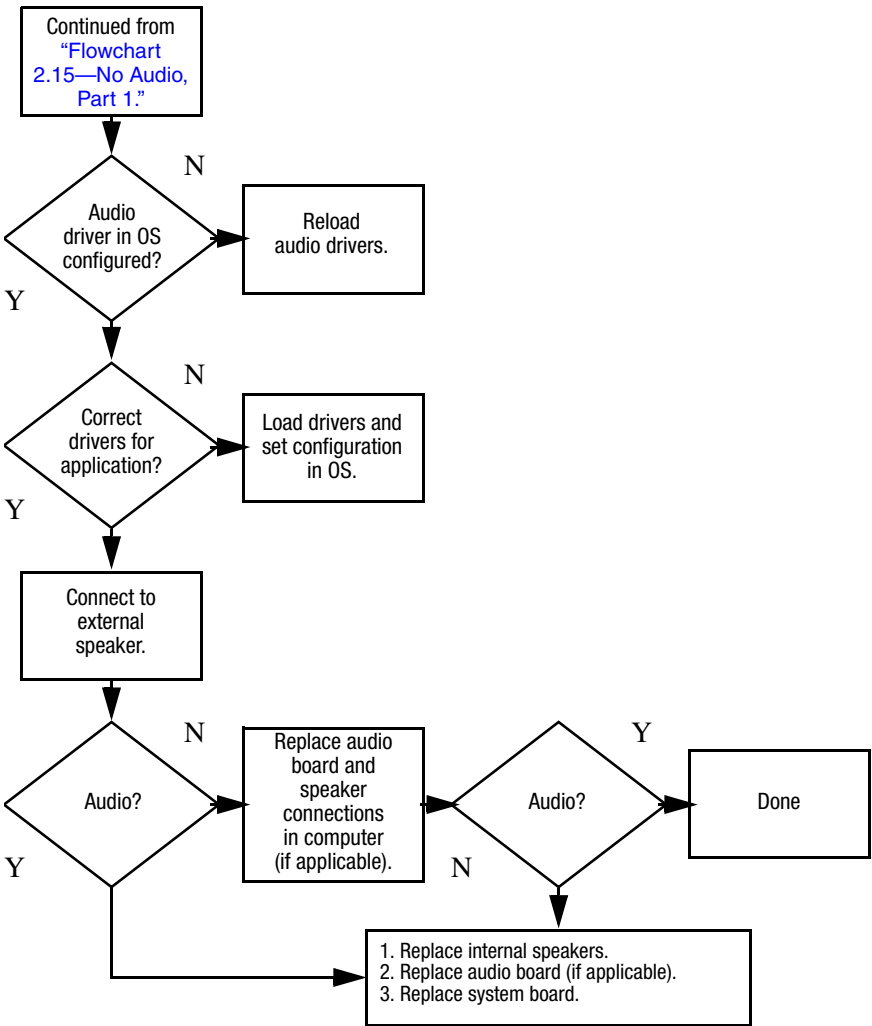
## Flowchart 2.14—No OS Loading, Optical Drive



## Flowchart 2.15—No Audio, Part 1

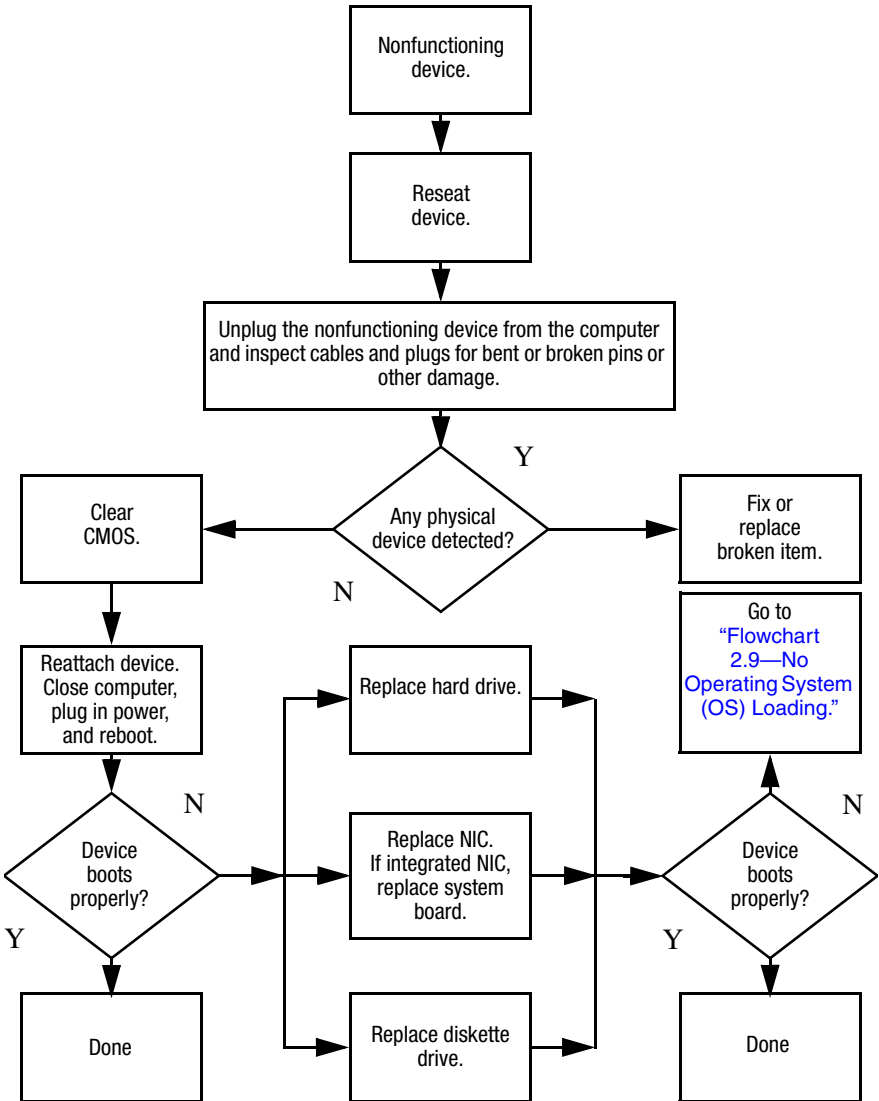


## Flowchart 2.16—No Audio, Part 2

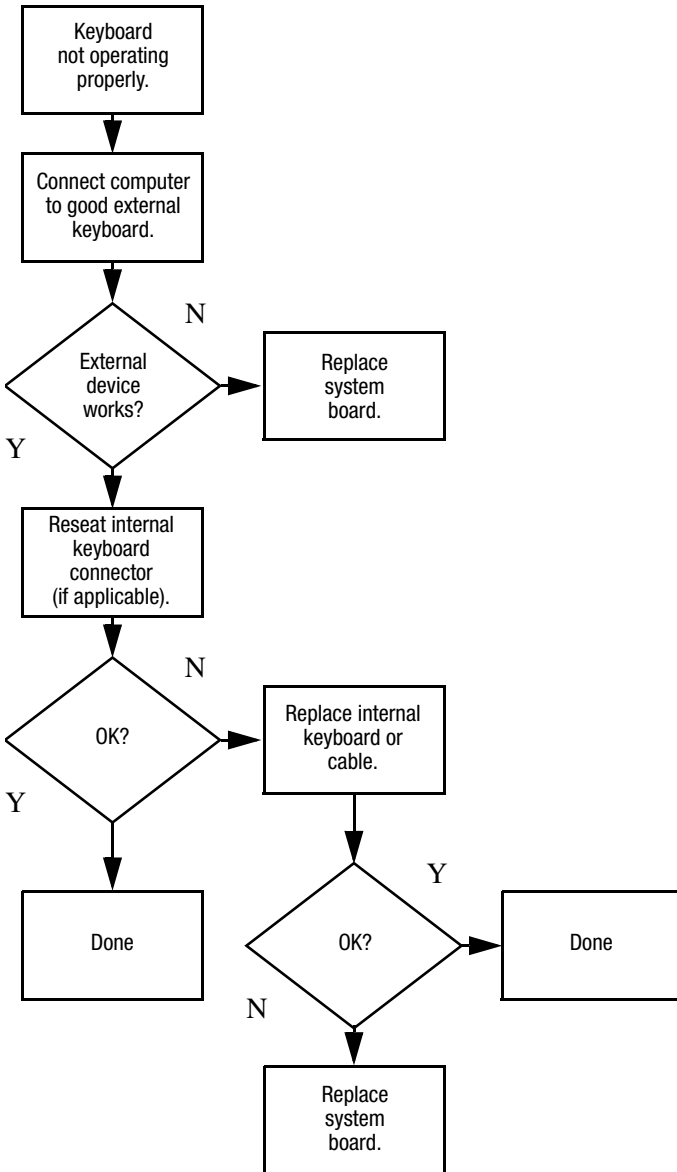




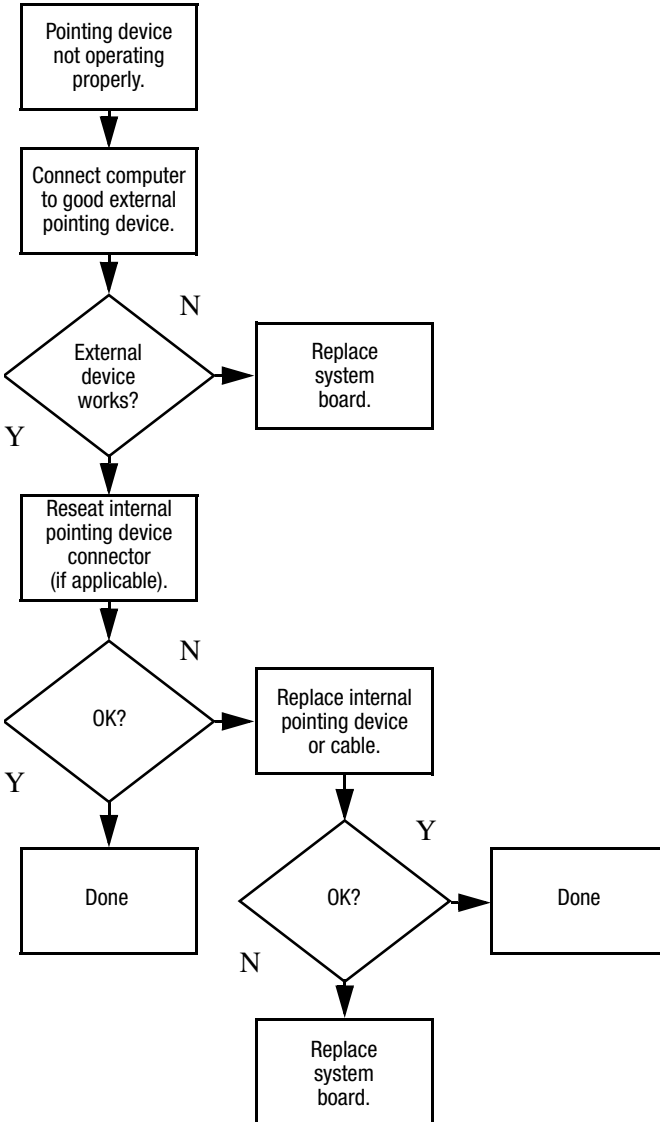
## Flowchart 2.17—Nonfunctioning Device



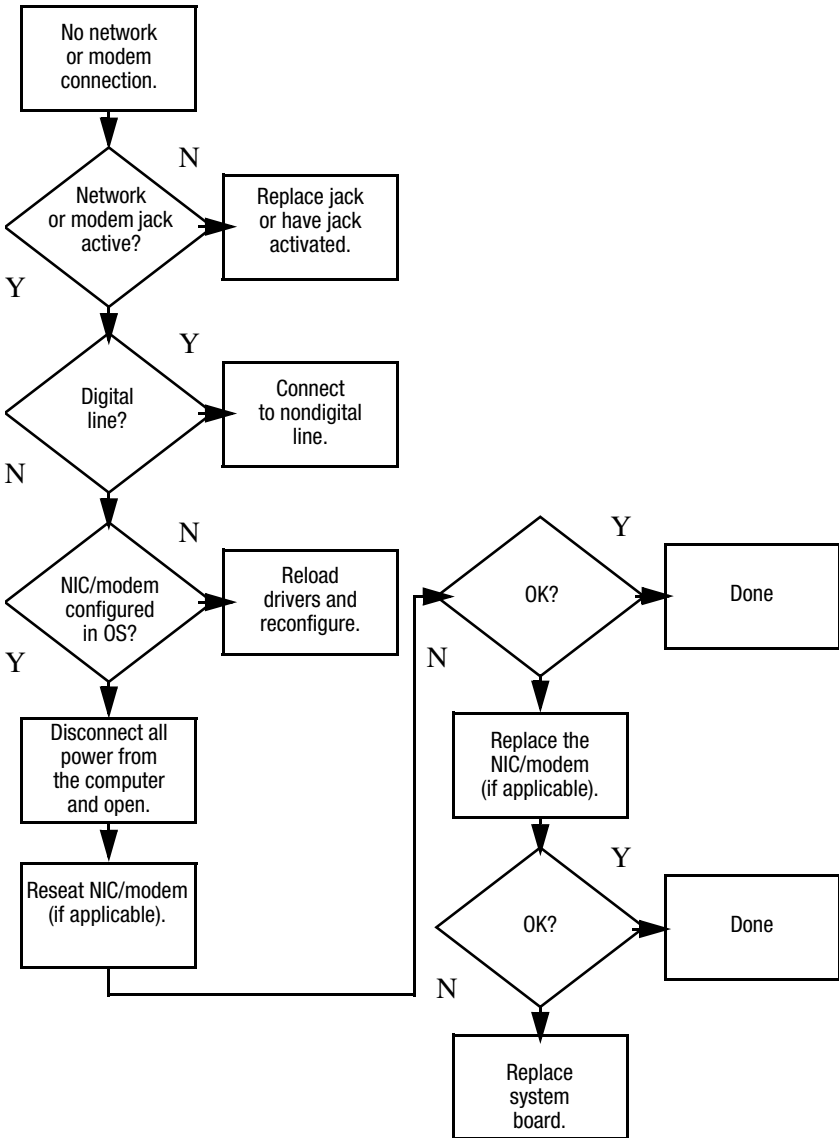
## Flowchart 2.18—Nonfunctioning Keyboard



## Flowchart 2.19—Nonfunctioning Pointing Device



## Flowchart 2.20—No Network/Modem Connection



# 3

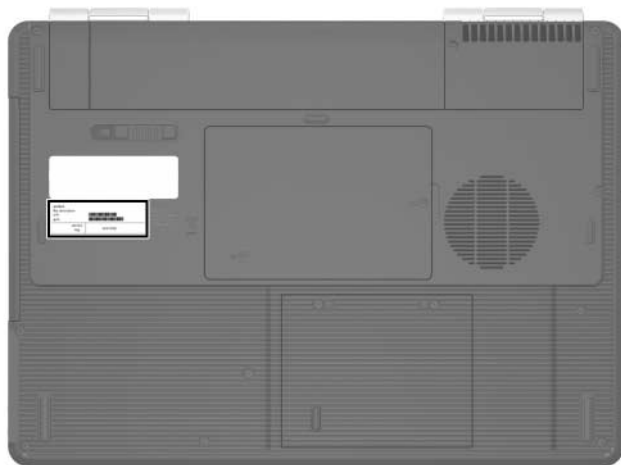
---

## Illustrated Parts Catalog

This chapter provides an illustrated parts breakdown and a reference for spare part numbers.

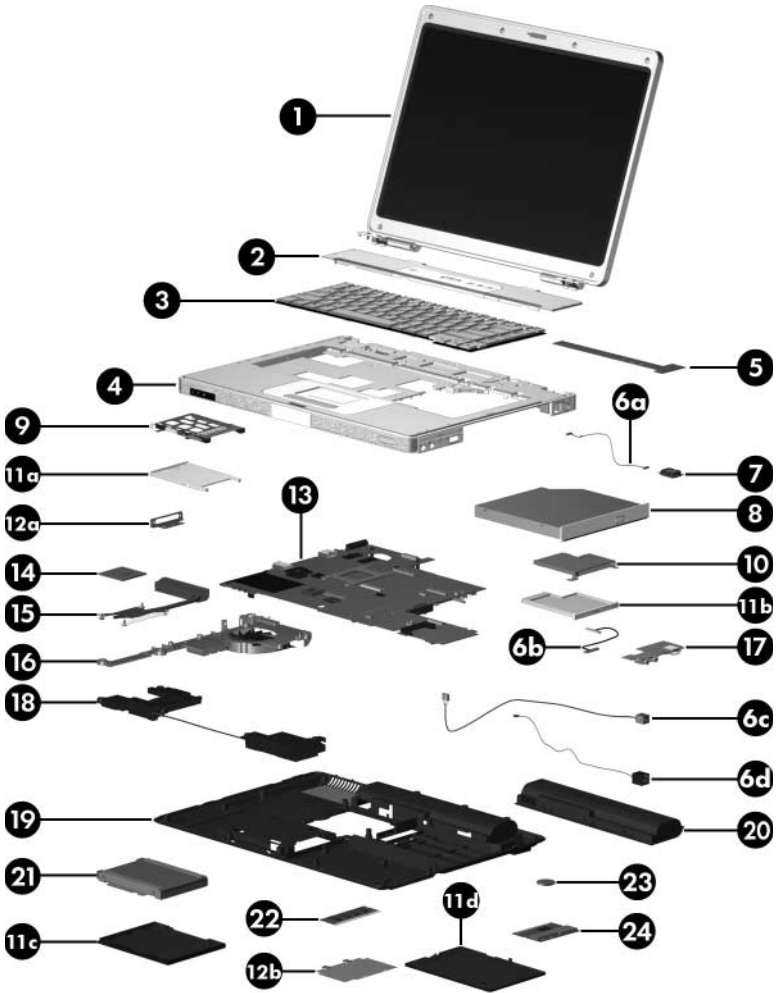
### 3.1 Serial Number Location

When ordering parts or requesting information, provide the computer serial number and model number located on the bottom of the computer.




*Serial Number Location*

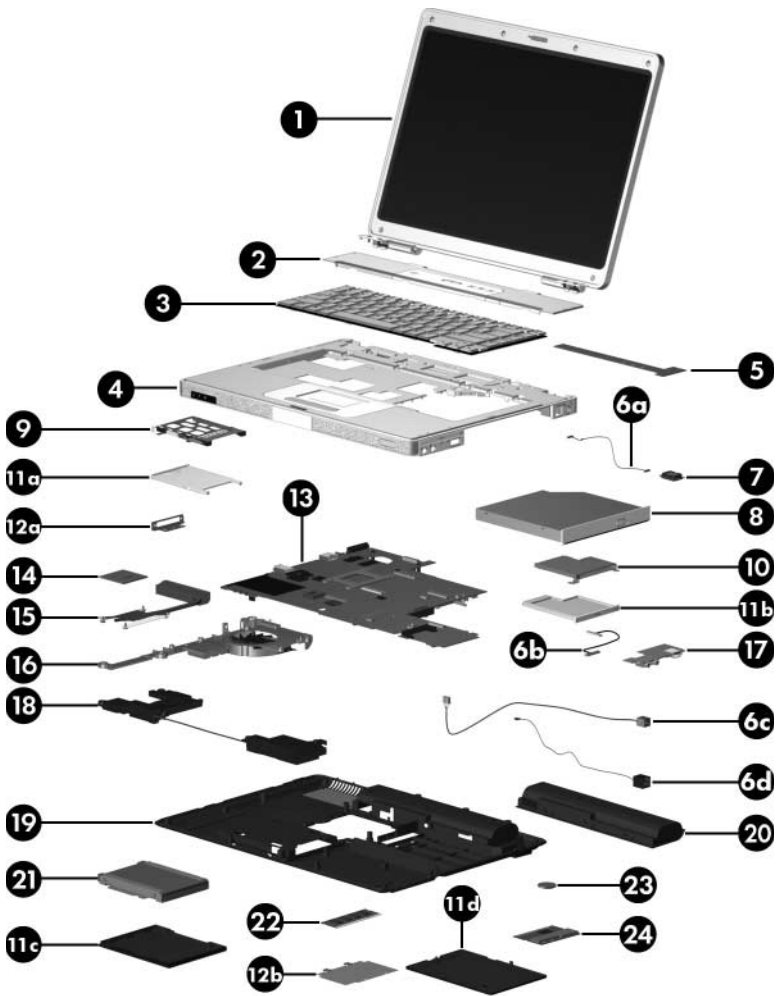
## 3.2 Computer Major Components



Computer Major Components

**Table 3-1**  
**Spare Parts: Computer Major Components**


Item	Description	Spare Part Number		
1	<b>Display assemblies</b> (include display cable, wireless antenna transceivers, and antenna cables)			
	15.4-inch, WXGA with BrightView	407842-001		
	15.4-inch, WXGA antiglare	407840-001		
	 Refer to <a href="#">Section 3.3, "Display Assembly Subcomponents,"</a> for display assembly internal component spare part number information.			
2	<b>Switch cover</b>			
	For use with full-featured models	407827-001		
	For use with defeatured models	407828-001		
3	<b>Keyboards</b>			
	Denmark	407856-081	Spain	407856-071
	France	407856-051	Sweden/Finland	407587-B71
	French Canada	407856-121	The United Kingdom	407856-031
	International	407856-B31		
	Italy	407856-061	The United States	407856-001
	Norway	407856-091		
4	<b>Top covers</b> (include TouchPad)			
	For use with full-featured models	407823-001		
	For use with defeatured models	407824-001		
	<b>TouchPad cable</b> (not illustrated)	407801-001		
	<b>TouchPad bracket</b> (not illustrated)	407812-001		
5	<b>LED board</b> (includes LED board cable)	417024-001		

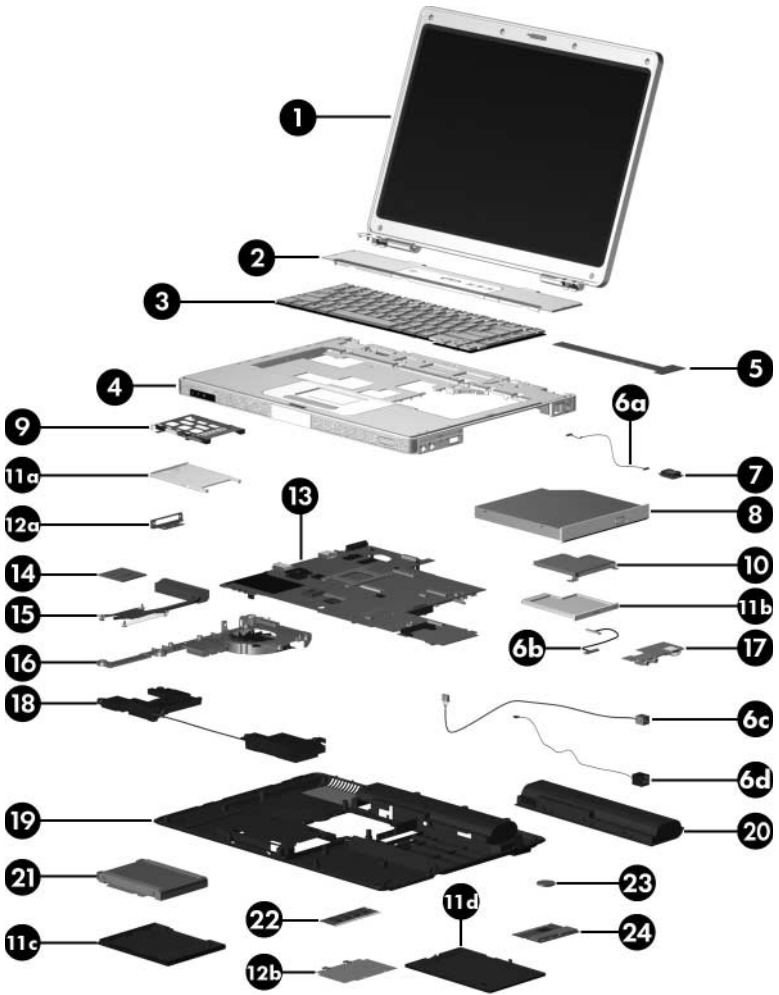


Computer Major Components




**Table 3-1****Spare Parts: Computer Major Components (Continued)**

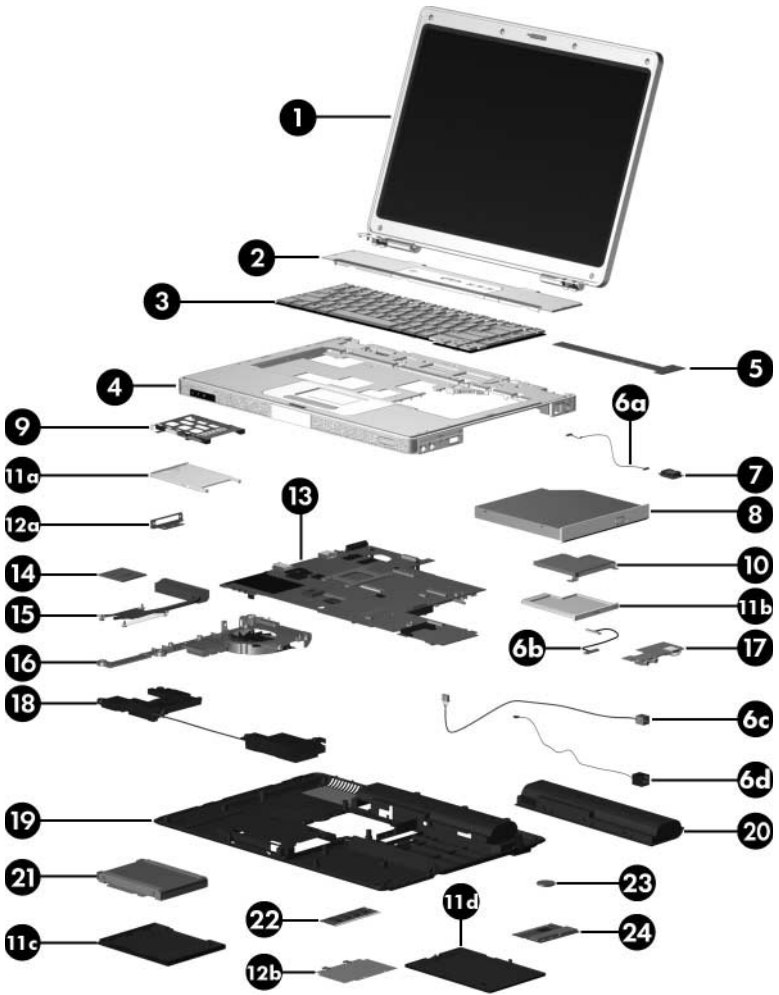
<b>Item</b>	<b>Description</b>	<b>Spare Part Number</b>
	<b>Cable Kit,</b>	407775-001
	Includes:	
6a	Bluetooth module cable	
6b	USB/audio board cable	
6c	Power connector cable	
	 The power connector cable is also available using spare part number 415564-001.	
6d	Modem connector cable	
7	<b>Bluetooth® module</b> (includes Bluetooth module cable)	397922-001
8	<b>Optical drives</b>	
	DVD±RW and CD-RW Double-Layer Combo Drive	413101-001
	DVD/CD-RW Double-Layer Combo Drive with LightScribe	413101-001
	DVD/CD-RW Combo Drive	413100-001
	DVD±RW and CD-RW Super Multi Double-Layer Combo Drive	430858-001
	DVD/CD-RW Super Multi Double-Layer Combo Drive with LightScribe and Hitachi LG Data Storage	430859-001
	DVD/CD-RW Super Multi Double-Layer Combo Drive with LightScribe and Hitachi LG Data Storage	417699-001
9	<b>PC Card assembly</b>	407829-001
10	<b>ExpressCard assembly</b>	407810-001



Computer Major Components

**Table 3-1****Spare Parts: Computer Major Components (Continued)**

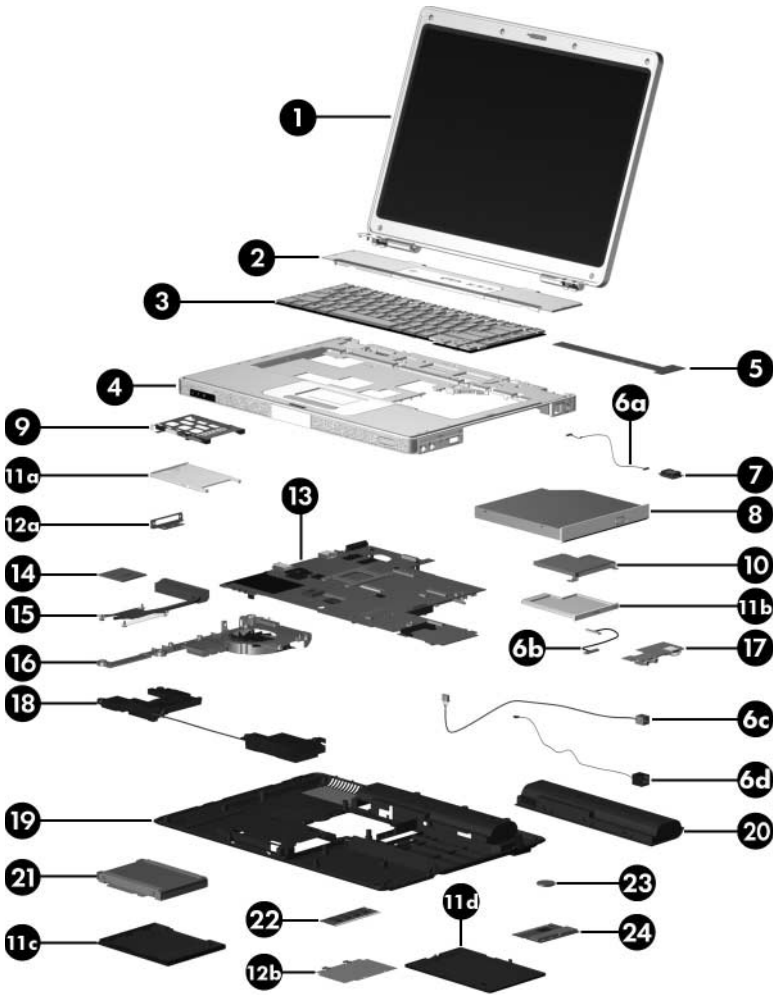
<b>Item</b>	<b>Description</b>	<b>Spare Part Number</b>
	<b>Plastics Kit</b>	407779-001
	Includes:	
11a	PC Card slot bezel	
11b	ExpressCard slot bezel	
11c	Hard drive cover (includes 2 captive screws)	
	 The hard drive cover is also available using spare part number 419328-001.	
11d	Memory/Mini PCI module compartment cover (includes 2 captive screws) Computer feet (8, not illustrated)	
	<b>Bracket Kit</b>	407821-001
	Includes:	
12a	Expansion port 2 bracket	
12b	Memory shield	
13	<b>System board</b>	
	For use with full-featured models	430151-001
	For use with defeatured models	430150-001
14	<b>Processors</b> (include thermal paste)	
	AMD Turion 64 ML-40 (2.2-GHz)	430499-001
	AMD Turion 64 ML-40 (2.2-GHz)	393579-001
	AMD Turion 64 ML-37 (2.0-GHz)	393578-001
	AMD Turion 64 ML-34 (1.8-GHz)	407836-001
	AMD Turion 64 ML-32 (1.8-GHz)	395744-001
	Mobile AMD Sempron M3300 (2.0-GHz)	407837-001
	Mobile AMD Sempron M3100 (1.8-GHz)	430855-001
	Mobile AMD Sempron M3000 (1.8-GHz)	407838-001



Computer Major Components

**Table 3-1****Spare Parts: Computer Major Components (Continued)**

<b>Item</b>	<b>Description</b>	<b>Spare Part Number</b>
15	<b>Heat sink</b> (includes thermal paste)	403827-001
	<b>Thermal paste</b>	407817-001
16	<b>Fan assembly</b>	407808-001
17	<b>USB/audio board</b> (includes USB/audio board cable)	
	For use with full-featured models	417027-001
	For use with defeatured models	417028-001
18	<b>Speakers</b>	407785-001
19	<b>Base enclosures</b>	
	For use with full-featured models	415493-001
	For use with defeatured models	415494-001
20	<b>Batteries</b>	
	12-cell, 8.8-Amp hour	407835-001
	6-cell, 4.0-Amp hour	407834-001
21	<b>Hard drives</b> (include frame and connector)	
	5400-rpm, 80-GB	407852-001
	4200-rpm, 120-GB	407853-001
	4200-rpm, 100-GB	407851-001
	4200-rpm, 80-GB	410054-001
	4200-rpm, 60-GB	407850-001
	4200-rpm, 40-GB	407849-001
<b>Hard drive cover</b> (identified by number 11c)	419328-001	

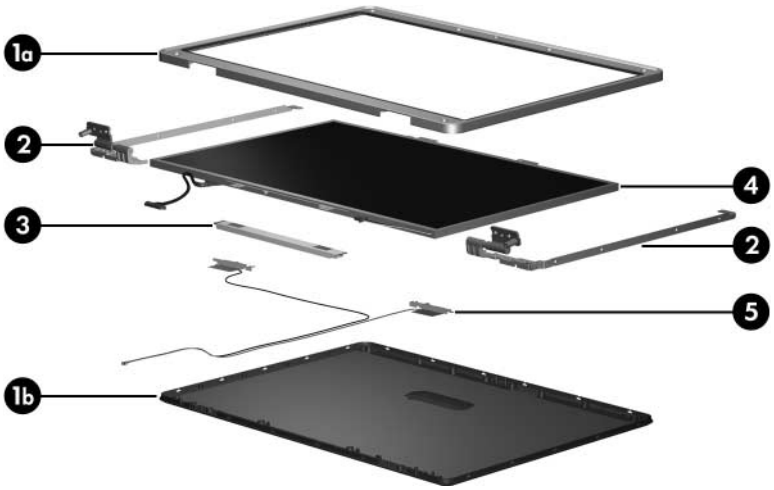


Computer Major Components

**Table 3-1****Spare Parts: Computer Major Components (Continued)**

<b>Item</b>	<b>Description</b>	<b>Spare Part Number</b>
22	<b>Memory modules, 1-DIMM</b>	<b>SD Memory Cards</b> (not illustrated)
	1024 MB                      403800-001	512 MB                      407316-001
	512 MB                        403799-001	256 MB                      403573-001
	256 MB                        407843-001	
23	<b>RTC battery</b> (includes tape)	407816-001
24	<b>Mini PCI communications modules</b>	
	802.11a/b/g WLAN module for use in North America	403791-001
	802.11a/b/g WLAN module for use in the rest of the world	403792-001
	802.11b/g WLAN module for use in North America	392557-001
	802.11b/g WLAN module for use in the rest of the world	392557-002

### 3.3 Display Assembly Subcomponents

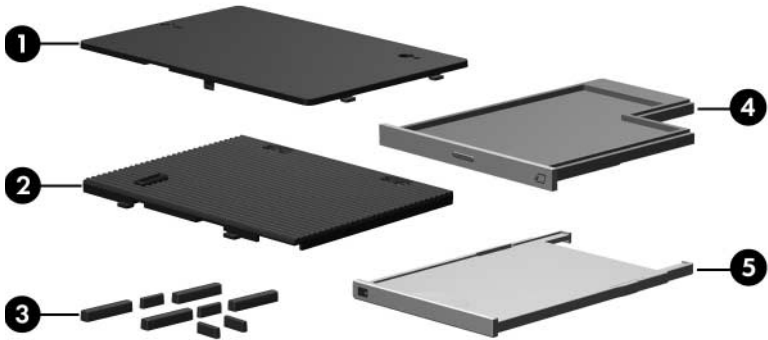





**Table 3-2**  
**Display Assembly Subcomponents**  
**Spare Part Number Information**

<b>Item</b>	<b>Description</b>	
	<b>Display Plastics Kit</b>	407793-001
	Includes:	
1a	■ Display bezel	
1b	■ Display enclosure	
	■ Display hinge base covers (not illustrated)	
	■ Display hinge covers (not illustrated)	
	<b>Display Hinge Kit</b>	407797-001
	Includes:	
2	■ Display hinges	
	■ Display release hook (not illustrated)	
3	<b>Display inverter board</b>	407800-001
4	<b>Display Panel Kit</b> (includes display panel cable)	
	15.4-inch, WXGA with BrightView	407799-001
	15.4-inch, WXGA antiglare	407798-001
5	<b>Wireless Antenna Kit</b> (includes cable and transceivers)	410118-001
	<b>Display Label Kit</b> (not illustrated)	407865-001
	<b>Display Screw Kit</b> (not illustrated)	407795-001
	Includes:	
	■ Phillips PM2.5×7.0 screws	
	■ Phillips PM2.5×5.0 screws	
	■ Rubber screw covers	

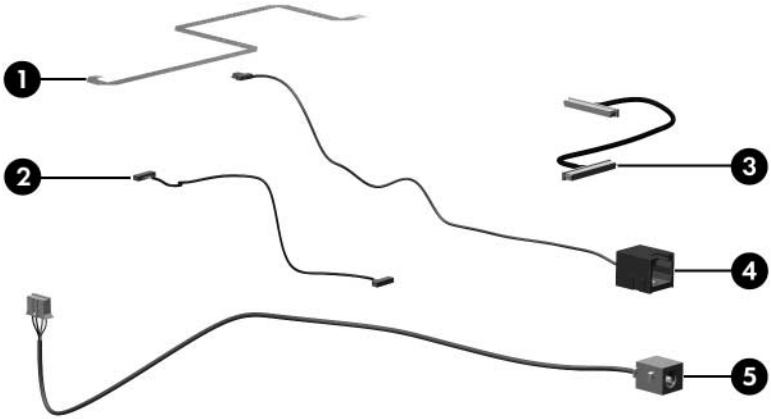
### 3.4 Plastics Kit



**Table 3-3**  
**Plastics Kit**  
**Spare Part Number Information**


Item	Description	Spare Part Number
	<b>Plastics Kit</b>	407779-001
	Includes:	
1	Memory/Mini PCI module compartment cover (includes 2 captive screws, secured by C-clips)	
2	Hard drive cover (includes 2 captive screws, secured by C-clips)	
	 The hard drive cover is also available using spare part number 419328-001.	
3	Computer feet (8)	
4	ExpressCard slot bezel	
5	PC Card slot bezel	

### 3.5 Cable Kit



**Table 3-4**  
**Cable Kit**

**Spare Part Number Information**

Item	Description	Spare Part Number
	<b>Cable Kit</b>	407775-001
	Includes:	
1	TouchPad cable	
2	Bluetooth module cable	
3	USB/audio board cable	
4	Modem connector cable	
5	Power connector cable	
	 The power connector cable is also available using spare part number 415564-001.	

## **3.6 Mass Storage Devices**



**Table 3-5**  
**Mass Storage Devices**  
**Spare Part Number Information**

Item	Description	Spare Part Number
1	<b>Hard drives</b> (include frame and connector)	
	5400-rpm, 80-GB      407852-001      4200-rpm, 120-GB	407853-001
		4200-rpm, 100-GB      407851-001
		4200-rpm, 80-GB      410054-001
		4200-rpm, 60-GB      407850-001
		4200-rpm, 40-GB      407849-001
2	<b>Optical drives</b>	
	DVD±RW and CD-RW Double-Layer Combo Drive	413101-001
	DVD/CD-RW Double-Layer Combo Drive with LightScribe	413101-001
	DVD/CD-RW Combo Drive	413100-001
	DVD±RW and CD-RW Super Multi Double-Layer Combo Drive	430858-001
	DVD/CD-RW Super Multi Double-Layer Combo Drive with LightScribe and Hitachi LG Data Storage	430859-001
	DVD/CD-RW Super Multi Double-Layer Combo Drive with LightScribe and Hitachi LG Data Storage	417699-001
	<b>USB digital drive</b> (not illustrated)	364727-001

## 3.7 Miscellaneous (Not Illustrated)

---

**Table 3-6**  
**Miscellaneous (Not Illustrated)**  
**Spare Part Information**

<b>Description</b>	<b>Spare Part Number</b>
All-in-one media cable	375759-001
Analog TV tuner	407941-001
Audio Y-cable 2	379452-001
Composite S-Video and audio cable	407939-001
DVB-T TV tuner	412175-001
DVB-T TV tuner antenna	412176-001
Label Kit	407777-001
Power supply, 65 watt	403810-001
RF cable	408485-001
RF input adapter cable	407940-001
Rubber Pad Kit	407781-001
TV tuner remote control	408479-001
USB infrared receiver	408483-001

**Table 3-6**  
**Miscellaneous (Not Illustrated)**  
**Spare Part Information (Continued)**

Description	Spare Part Number
<b>Power cords</b>	
For use in:	
Australia	403811-011
Canada, French Canada, and the United States	403811-001
Denmark	403811-081
France, Germany, and Spain	403811-021
Israel	403811-BB1
The United Kingdom	403811-031
Switzerland	403811-111
Italy	403811-061
<b>Screw Kit</b> (includes the following screws; refer to Appendix A, "Screw Listing," for more information on specifications and usage)	407783-001
<ul style="list-style-type: none"> <li>■ Phillips PM3.0×6.0 screw</li> <li>■ Phillips PM3.0×4.0 screw</li> <li>■ Phillips PM2.5×13.0 screw</li> <li>■ Phillips PM2.5×9.0 screw</li> <li>■ Phillips PM2.5×7.0 screw</li> <li>■ Phillips PM2.5×5.0 screw</li> <li>■ Phillips PM2.5×5.0 Captive screw</li> </ul>	<ul style="list-style-type: none"> <li>■ Black Phillips PM2.5×4.0 screw</li> <li>■ Silver Phillips PM2.5×4.0 screw</li> <li>■ Phillips PM2.0×4.0 screw</li> <li>■ Phillips PM2.0×3.0 screw</li> <li>■ Phillips PM1.5×3.0 screw</li> <li>■ Slotted SM1.5×9.0 screw</li> </ul>
<b>USB travel mouse</b>	309674-001
<b>USB digital drive</b>	364727-001
<b>Wired headset with volume control</b>	371693-001

## 3.8 Sequential Part Number Listing

---

**Table 3-7**  
**Sequential Part Number Listing**

<b>Spare Part Number</b>	<b>Description</b>
309674-001	USB travel mouse
364727-001	USB digital drive
371693-001	Wired headset with volume control
392557-001	802.11b/g WLAN Mini PCI communications module for use in North America
392557-002	802.11b/g WLAN Mini PCI communications module for use in the rest of the world
393578-001	AMD Turion 64 ML-37 (2.0-GHz) processor (includes thermal paste)
393579-001	AMD Turion 64 ML-40 (2.2-GHz) processor (includes thermal paste)
395744-001	AMD Turion 64 ML-32 (1.8-GHz) processor (includes thermal paste)
397922-001	Bluetooth wireless module (includes Bluetooth module cable)
403573-001	SD Memory Card 256-MB
403791-001	802.11a/b/g WLAN Mini PCI communications module for use in North America
403792-001	802.11a/b/g WLAN Mini PCI communications module for use in the rest of the world
403799-001	512-MB memory module
403800-001	1024-MB memory module
403810-001	Power supply, 65 watt
403811-001	Power cord for use in the United States
403811-011	Power cord for use in Australia

---



**Table 3-7**  
**Sequential Part Number Listing (*Continued*)**

<b>Spare Part Number</b>	<b>Description</b>
403811-021	Power cord for use internationally
403811-031	Power cord for use in the United Kingdom
403811-061	Power cord for use in Italy
403811-081	Power cord for use in Denmark
403811-111	Power cord for use in Switzerland
403811-BB1	Power cord for use in Israel
403827-001	Heat sink
407316-001	SD Memory Card 512-MB
407775-001	Cable Kit
407777-001	Label Kit
407779-001	Plastics Kit
407781-001	Rubber Pad Kit
407783-001	Screw Kit
407785-001	Speakers
407793-001	Display Plastics Kit
407795-001	Display Screw Kit
407797-001	Display HInge Kit
407798-001	Display panel kit for use with antiglare displays
407799-001	Display panel kit for use with BrightView displays
407800-001	Display inverter board
407801-001	TouchPad cable
407808-001	Fan assembly

**Table 3-7**  
**Sequential Part Number Listing (*Continued*)**

<b>Spare Part Number</b>	<b>Description</b>
407809-001	ExpressCard assembly
407812-001	TouchPad bracket
407816-001	RTC battery (includes tape)
407817-001	Thermal paste
407821-001	Bracket Kit
407823-001	Top cover for use with full-featured computers
407824-001	Top cover for use with defeatured computers
407827-001	Switch cover for use with full-featured computers
407828-001	Switch cover for use with defeatured computers
407829-001	PC Card assembly
407834-001	6-cell, 4.0-Amp hour battery
407835-001	12-cell, 8.8-Amp hour battery
407836-001	AMD Turion 64 ML-34 (1.8-GHz) processor (includes thermal paste)
407837-001	Mobile AMD Sempron M3000 (1.8-GHz) processor (includes thermal paste)
407838-001	Mobile AMD Sempron M3300 (2.0-GHz) processor (includes thermal paste)
407840-001	15.4-inch WXGA antiglare display assembly
407842-001	15.4-inch WXGA display assembly with BrightView
407843-001	256-MB, 1-DIMM memory module
407849-001	4200-rpm, 40-GB hard drive
407850-001	4200-rpm, 60-GB hard drive
407851-001	4200-rpm, 100-GB hard drive

**Table 3-7**  
**Sequential Part Number Listing (*Continued*)**

<b>Spare Part Number</b>	<b>Description</b>
407852-001	5400-rpm, 80-GB hard drive
407853-001	4200-rpm, 120-GB hard drive
407856-001	Keyboard for use in the United States
407856-031	Keyboard for use in the United Kingdom
407856-051	Keyboard for use in France
407856-061	Keyboard for use in Italy
407856-071	Keyboard for use in Spain
407856-081	Keyboard for use in Denmark
407856-091	Keyboard for use in Norway
407856-121	Keyboard for use in French Canada
407856-B31	Keyboard for use internationally
407856-B71	Keyboard for use in Sweden and Finland
407865-001	Display Label Kit
407939-001	Composite S-Video and audio cable
407940-001	RF input adapter cable
407941-001	Analog TV tuner
408479-001	TV tuner remote control
408483-001	USB infrared receiver
408485-001	RF cable
410054-001	4200-rpm, 80-GB hard drive
410118-001	Wireless Antenna Cable Kit (includes transceivers and cables)
412175-001	DVB-T TV tuner

**Table 3-7**  
**Sequential Part Number Listing (*Continued*)**

<b>Spare Part Number</b>	<b>Description</b>
412176-001	DVB-T TV tuner antenna
413100-001	DVD/CD-RW Combo Drive
413101-001	DVD±RW and CD-RW Double-Layer Combo Drive
413102-001	DVD/CD-RW Double-Layer Combo Drive with LightScribe
415493-001	Base enclosure for use with full-featured computer models
415494-001	Base enclosure for use with defeatured computer models
415564-001	Power connector cable
417024-001	LED board
417027-001	USB/audio board for use with full-featured computers
417028-001	USB/audio board for use with defeatured computers
417699-001	DVD/CD-RW Super Multi Combo Drive with Hitachi LG Data Storage
419328-001	Hard drive cover
430150-001	System board for use with defeatured computers
430151-001	System board for use with full-featured computers
430499-001	AMD Turion 64 ML-40 (2.2-GHz) processor (includes thermal paste)
430855-001	Mobile AMD Sempron-M 3100 (1.8-GHz) processor (includes thermal paste)
430858-001	DVD±RW and CD-RW Super Multi Double-Layer Combo Drive with LightScribe
430859-001	DVD/CD-RW Super Multi Double-Layer Combo Drive with LightScribe and Hitachi LG Data Storage

---

## Removal and Replacement Preliminaries

This chapter provides essential information for proper and safe removal and replacement service.y

### 4.1 Tools Required

You will need the following tools to complete the removal and replacement procedures:

- Magnetic screwdriver
- Phillips P0 and P1 screwdrivers
- Flat-bladed screwdriver

## 4.2 Service Considerations

The following sections include some of the considerations that you should keep in mind during disassembly and assembly procedures.



As you remove each subassembly from the computer, place the subassembly (and all accompanying screws) away from the work area to prevent damage.

---

### Plastic Parts

Using excessive force during disassembly and reassembly can damage plastic parts. Use care when handling the plastic parts. Apply pressure only at the points designated in the maintenance instructions.

### Cables and Connectors

---



**CAUTION:** When servicing the computer, ensure that cables are placed in their proper locations during the reassembly process. Improper cable placement can damage the computer.

---

Cables must be handled with extreme care to avoid damage. Apply only the tension required to unseat or seat the cables during removal and insertion. Handle cables by the connector whenever possible. In all cases, avoid bending, twisting, or tearing cables. Ensure that cables are routed in such a way that they cannot be caught or snagged by parts being removed or replaced. Handle flex cables with extreme care; these cables tear easily.

## 4.3 Preventing Damage to Removable Drives

Removable drives are fragile components that must be handled with care. To prevent damage to the computer, damage to a removable drive, or loss of information, observe the following precautions:

- Before removing or inserting a hard drive, shut down the computer. If you are unsure whether the computer is off or in Hibernation, turn the computer on, and then shut it down through the operating system.
- Before removing a diskette drive or optical drive, ensure that a diskette or disc is not in the drive and ensure that the optical drive tray is closed.
- Before handling a drive, ensure that you are discharged of static electricity. While handling a drive, avoid touching the connector.
- Handle drives on surfaces covered with at least one inch of shock-proof foam.
- Avoid dropping drives from any height onto any surface.
- After removing a hard drive, CD-ROM drive, or a diskette drive, place it in a static-proof bag.
- Avoid exposing a hard drive to products that have magnetic fields, such as monitors or speakers.
- Avoid exposing a drive to temperature extremes or liquids.
- If a drive must be mailed, place the drive in a bubble pack mailer or other suitable form of protective packaging and label the package, "FRAGILE: Handle With Care."

## **4.4 Preventing Electrostatic Damage**

Many electronic components are sensitive to electrostatic discharge (ESD). Circuitry design and structure determine the degree of sensitivity. Networks built into many integrated circuits provide some protection, but in many cases, the discharge contains enough power to alter device parameters or melt silicon junctions.

A sudden discharge of static electricity from a finger or other conductor can destroy static-sensitive devices or microcircuitry. Often the spark is neither felt nor heard, but damage occurs.

An electronic device exposed to electrostatic discharge might not be affected at all and can work perfectly throughout a normal cycle. Or the device might function normally for a while, then degrade in the internal layers, reducing its life expectancy.



## **4.5 Packaging and Transporting Precautions**

Use the following grounding precautions when packaging and transporting equipment:

- To avoid hand contact, transport products in static-safe containers, such as tubes, bags, or boxes.
- Protect all electrostatic-sensitive parts and assemblies with conductive or approved containers or packaging.
- Keep electrostatic-sensitive parts in their containers until the parts arrive at static-free workstations.
- Place items on a grounded surface before removing items from their containers.
- Always be properly grounded when touching a sensitive component or assembly.
- Store reusable electrostatic-sensitive parts from assemblies in protective packaging or nonconductive foam.
- Use transporters and conveyors made of antistatic belts and roller bushings. Ensure that mechanized equipment used for moving materials is wired to ground and that proper materials are selected to avoid static charging. When grounding is not possible, use an ionizer to dissipate electric charges.

## 4.6 Workstation Precautions

Use the following grounding precautions at workstations:

- Cover the workstation with approved static-shielding material (refer to [Table 4-2, “Static-Shielding Materials”](#)).
- Use a wrist strap connected to a properly grounded work surface and use properly grounded tools and equipment.
- Use conductive field service tools, such as cutters, screwdrivers, and vacuums.
- When using fixtures that must directly contact dissipative surfaces, only use fixtures made of static-safe materials.
- Keep the work area free of nonconductive materials, such as ordinary plastic assembly aids and Styrofoam.
- Handle electrostatic-sensitive components, parts, and assemblies by the case or PCM laminate. Handle these items only at static-free workstations.
- Avoid contact with pins, leads, or circuitry.
- Turn off power and input signals before inserting or removing connectors or test equipment.

## 4.7 Grounding Equipment and Methods

Grounding equipment must include either a wrist strap or a foot strap at a grounded workstation.

- When seated, wear a wrist strap connected to a grounded system. Wrist straps are flexible straps with a minimum of one megohm  $\pm 10\%$  resistance in the ground cords. To provide proper ground, wear a strap snugly against the skin at all times. On grounded mats with banana-plug connectors, use alligator clips to connect a wrist strap.
- When standing, use foot straps and a grounded floor mat. Foot straps (heel, toe, or boot straps) can be used at standing workstations and are compatible with most types of shoes or boots. On conductive floors or dissipative floor mats, use foot straps on both feet with a minimum of one megohm resistance between the operator and ground. To be effective, the conductive strips must be worn in contact with the skin.

Other grounding equipment recommended for use in preventing electrostatic damage includes:

- Antistatic tape
- Antistatic smocks, aprons, and sleeve protectors
- Conductive bins and other assembly or soldering aids
- Nonconductive foam
- Conductive tabletop workstations with ground cords of one megohm resistance
- Static-dissipative tables or floor mats with hard ties to the ground
- Field service kits
- Static awareness labels
- Material-handling packages
- Nonconductive plastic bags, tubes, or boxes
- Metal tote boxes
- Electrostatic voltage levels and protective materials

Table 4-1 shows how humidity affects the electrostatic voltage levels generated by different activities.

---

**Table 4-1**  
**Typical Electrostatic Voltage Levels**

Event	Relative Humidity		
	10%	40%	55%
Walking across carpet	35,000 V	15,000 V	7,500 V
Walking across vinyl floor	12,000 V	5,000 V	3,000 V
Motions of bench worker	6,000 V	800 V	400 V
Removing DIPS from plastic tube	2,000 V	700 V	400 V
Removing DIPS from vinyl tray	11,500 V	4,000 V	2,000 V
Removing DIPS from Styrofoam	14,500 V	5,000 V	3,500 V
Removing bubble pack from PCB	26,500 V	20,000 V	7,000 V
Packing PCBs in foam-lined box	21,000 V	11,000 V	5,000 V



A product can be degraded by as little as 700 V.

---

Table 4-2 lists the shielding protection provided by antistatic bags and floor mats.

---

**Table 4-2**  
**Static-Shielding Materials**

Material	Use	Voltage Protection Level
Antistatic plastic	Bags	1,500 V
Carbon-loaded plastic	Floor mats	7,500 V
Metallized laminate	Floor mats	5,000 V

---

# 5

---

## Removal and Replacement Procedures

This chapter provides removal and replacement procedures.

There are as many 94 screws, in 13 different sizes, that may have to be removed, replaced, or loosened when servicing the computer. Make special note of each screw size and location during removal and replacement.

Refer to [Appendix A, “Screw Listing,”](#) for detailed information on screw sizes, locations, and usage.

## 5.1 Serial Number


Report the computer serial number to HP when requesting information or ordering spare parts. The serial number is located on the bottom of the computer.



*Serial Number Location*

## 5.2 Disassembly Sequence Chart

Use the chart below to determine the section number to be referenced when removing computer components.

Disassembly Sequence Chart		
Section	Description	# of Screws Removed
5.3	<a href="#">Preparing the Computer for Disassembly</a>	
	Battery	0
5.4	<a href="#">Hard Drive</a>	2 loosened to remove the hard drive cover 4 to disassemble the hard drive
5.5	<a href="#">Computer Feet</a>	0
5.6	<a href="#">Memory Module</a>	2 loosened to remove the memory/Mini PCI module compartment cover, 2 to release the memory shield
5.7	<a href="#">Mini PCI Communications Module</a>	0
	 To prevent an unresponsive system and the display of a warning message, install only a Mini PCI device authorized for use in your computer by the governmental agency that regulates wireless devices in your country. If you install a device and then receive a warning message, remove the device to restore computer functionality. Then contact Customer Care.	
5.8	<a href="#">RTC Battery</a>	0

---

### Disassembly Sequence Chart (*Continued*)

---

Section	Description	# of Screws Removed
5.9	Optical Drive	1 to remove the optical drive, 2 to remove the optical drive bracket
5.10	Switch Cover	2
5.11	Keyboard	4
5.12	Display Assembly	6
	Display bezel	6
	Display hinge base covers	2
	Display panel	4
	Display release hook	2
	Display hinges	8
	Wireless antenna transceivers and cables	2
5.13	Base Enclosure	18
5.14	Bluetooth Module	2
5.15	System Board	4
5.16	Display Release Button	6
5.17	LED Board	2
5.18	Heat Sink	4
5.19	Processor	1 loosened
5.20	Fan Assembly	6
5.21	PC Card Assembly	2
5.22	ExpressCard Assembly	2

---



## 5.3 Preparing the Computer for Disassembly

Before you begin any removal or installation procedures:

1. Shut down the computer. If you are unsure whether the computer is off or in hibernation, turn the computer on, and then shut it down through the operating system.
2. Disconnect all external devices connected to the computer.
3. Disconnect the power cord.

---

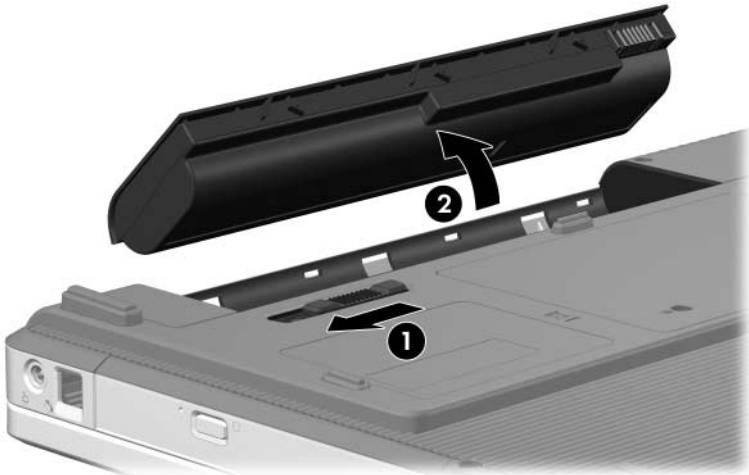
### Battery Spare Part Number Information

---

12-cell, 8.8-Amp hour	407835-001
6-cell, 4.0-Amp hour	407834-001

---

4. Remove the battery by following these steps:
  - a. Turn the computer upside down with the front toward you.
  - b. Slide the battery release latch **1** to the left. (The battery disengages from the computer.)
  - c. Lift the front edge of the battery **2** and swing it back to remove it.



*Removing the Battery*

Reverse the above procedure to install the battery.

## 5.4 Hard Drive

---

### Hard Drive Spare Part Number Information

---

5400-rpm, 80-GB	407852-001	4200-rpm, 120-GB	407853-001
		4200-rpm, 100-GB	407851-001
		4200-rpm, 80-GB	410054-001
		4200-rpm, 60-GB	407850-001
		4200-rpm, 40-GB	407849-001

---

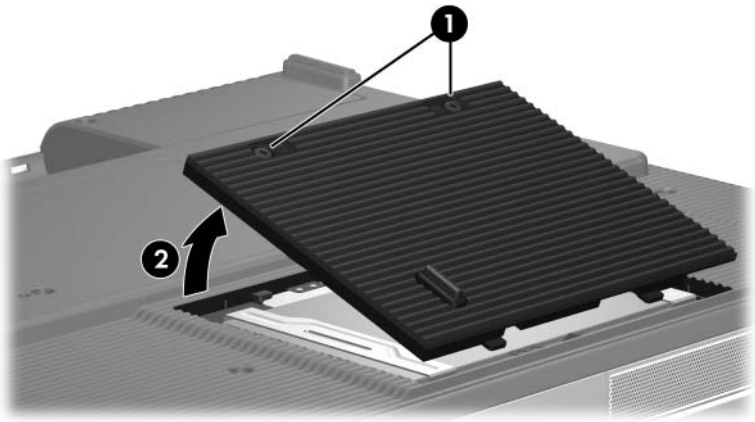
1. Prepare the computer for disassembly (refer to [Section 5.3](#)).

2. Loosen the two Phillips PM2.5×5.0 captive screws ❶ that secure the hard drive cover to the computer.
3. Lift the rear edge of the hard drive cover ❷, and then swing it up and forward and remove it.



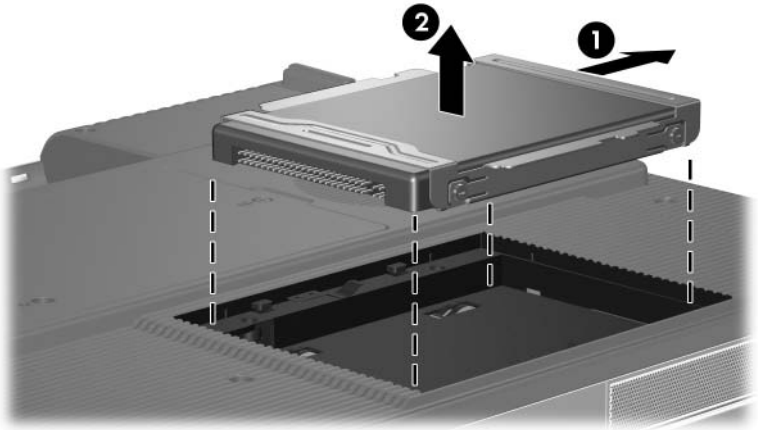
The hard drive cover is included in the Plastics Kit, spare part number 407779-001. The hard drive cover is also available using spare part number 419328-001.

---



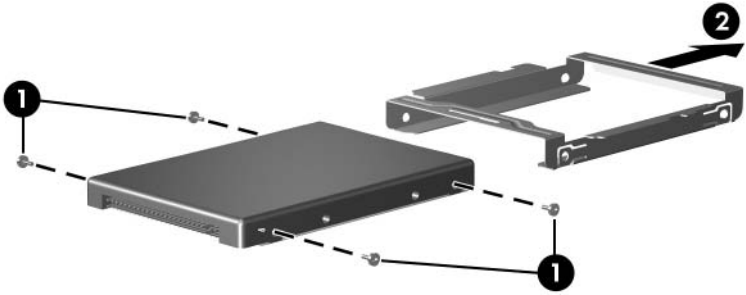
*Removing the Hard Drive Cover*

4. Use the tab **1** to slide the hard drive to the right, and then lift the hard drive **2** from the hard drive bay.



*Removing the Hard Drive*

5. Remove the four Phillips PM3.0×4.0 hard drive frame screws ❶ that secure the hard drive frame to the hard drive.
6. Slide the hard drive ❷ away from the hard drive to remove it.

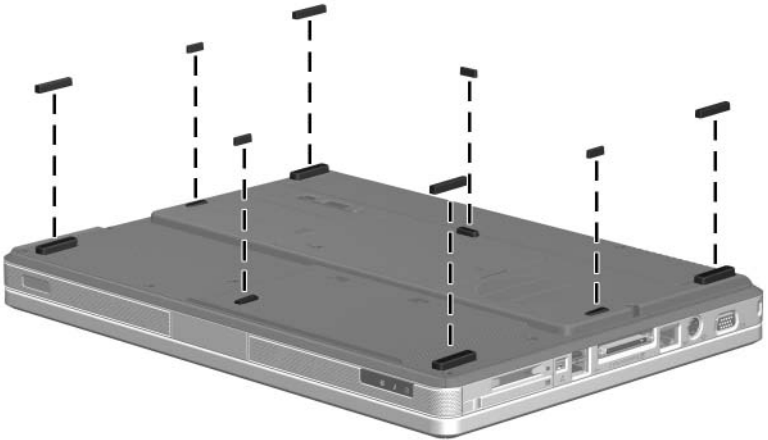


*Removing the Hard Drive Frame*

Reverse the above procedure to reassemble and install the hard drive.

## 5.5 Computer Feet

The computer feet are adhesive-backed rubber pads. The feet are included in the Plastics Kit, spare part number 407779-001.



*Replacing the Computer Feet*

## 5.6 Memory Module

---

### Memory Module Spare Part Number Information

---

Memory modules (1 DIMM)

1024 MB	403800-001
512 MB	403799-001
256 MB	407834-001

---

1. Prepare the computer for disassembly (refer to [Section 5.3](#)).

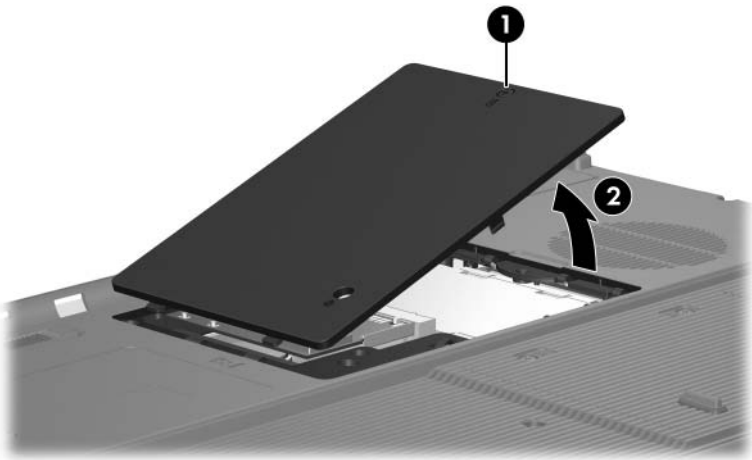


2. Loosen the Phillips PM2.5×5.0 captive screw ❶ that secures the memory/Mini PCI module compartment cover to the computer.
3. Lift the right side of the cover ❷ and swing it up and to the left and remove it.



The memory/Mini PCI module compartment cover is included in the Plastics Kit, spare part number 407779-001.

---



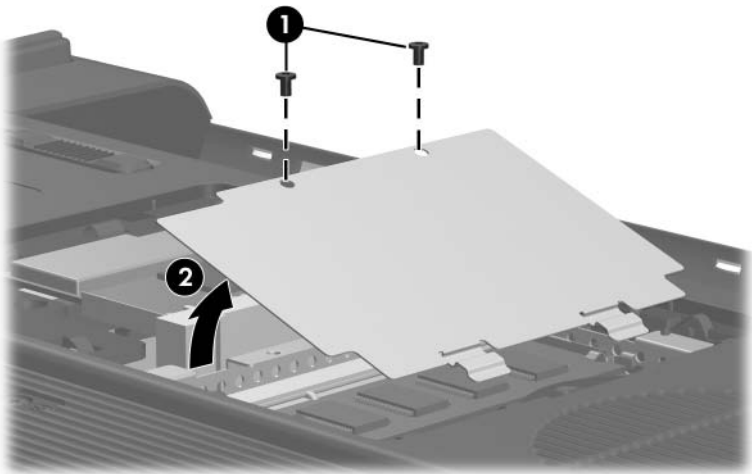
*Removing the Memory/Mini PCI Module Compartment Cover*

4. Remove the two Phillips PM2.5×4.0 screws ❶ that secure the memory shield to the computer.
5. Lift the left side of the shield ❷, and then swing it up and to the right.



The memory shield is available in the Bracket Kit, spare part number 407821-001.

---



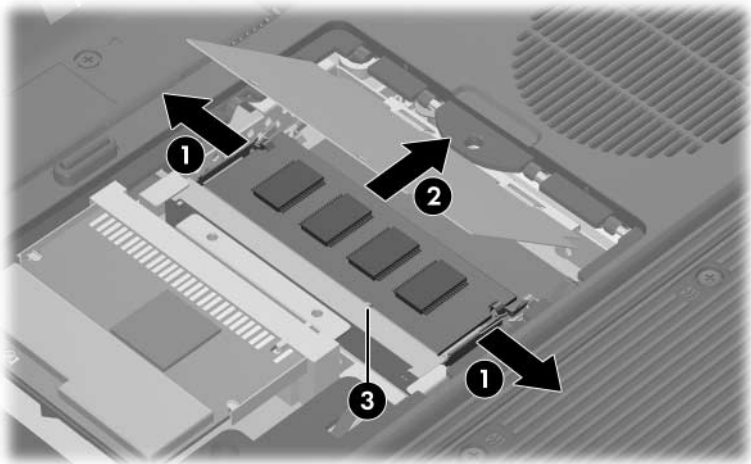
*Removing the Memory Shield*

6. Spread the retaining tabs **1** on each side of the memory module socket to release the memory module. (The edge of the module opposite the socket rises away from the computer.)
7. Remove the memory module by pulling the module away from the socket at an angle **2**.



Memory modules are designed with notches **3** to prevent incorrect installation into the memory module socket.

---



*Removing the Memory Module*

Reverse the above procedure to install a memory module.

## 5.7 Mini PCI Communications Module

---

### Mini PCI Communications Module Spare Part Number Information

---

802.11a/b/g WLAN module for use in North America	403791-001
802.11a/b/g WLAN module for use in the rest of the world	403792-001
802.11b/g wireless local access network (WLAN) module for use in North America	392557-001
802.11b/g WLAN module for use in the rest of the world	392557-002

---

1. Prepare the computer for disassembly ([Section 5.3](#)).
2. Remove the memory/Mini PCI module compartment cover ([Section 5.6](#)).



Before disconnecting the antenna cables, make note of which cable is attached to which antenna clip on the Mini PCI communications card.

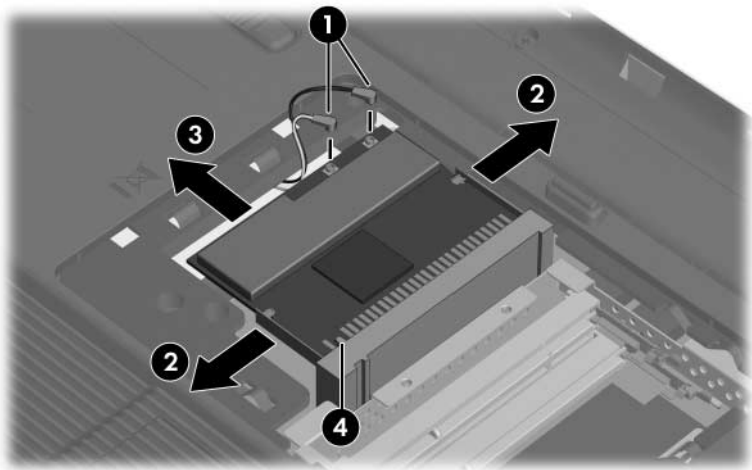
---

3. Disconnect the auxiliary and main **1** antenna cables from the Mini PCI communications module.
  4. Spread the two retaining tabs **2** on each side of the Mini PCI socket to release the Mini PCI communications module. (The edge of the module opposite the socket rises away from the computer.)
  5. Remove the Mini PCI communications module by pulling the module away from the socket at an angle **3**.
- 



Mini PCI communications modules are designed with notches **4** to prevent incorrect installation into the Mini PCI module socket.

---



*Removing a Mini PCI Communications Module*

Reverse the above procedure to install a Mini PCI communications module.

## 5.8 RTC Battery

---

### RTC Battery Spare Part Number Information

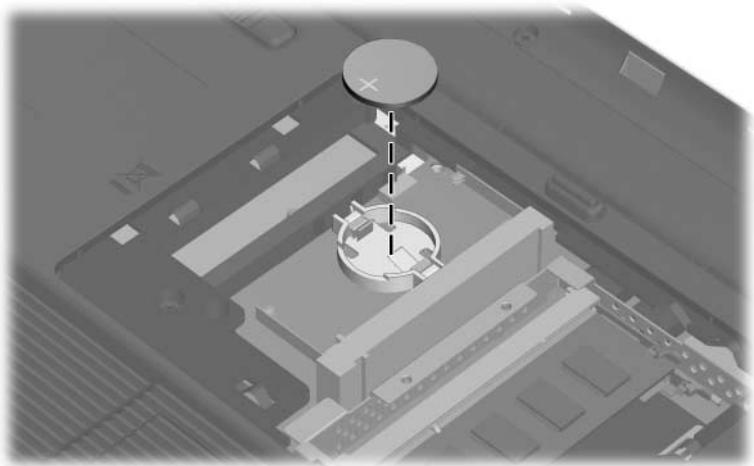
---

RTC battery (includes tape)

407816-001

---

1. Prepare the computer for disassembly ([Section 5.3](#)).
2. Remove the memory/Mini PCI module compartment cover ([Section 5.6](#)).
3. Remove the Mini PCI communications module ([Section 5.7](#)).
4. Remove the RTC battery from the socket on the system board.



*Removing the RTC Battery*

Reverse the above procedure to install an RTC battery.

## 5.9 Optical Drive

---

### Optical Drive Spare Part Number Information

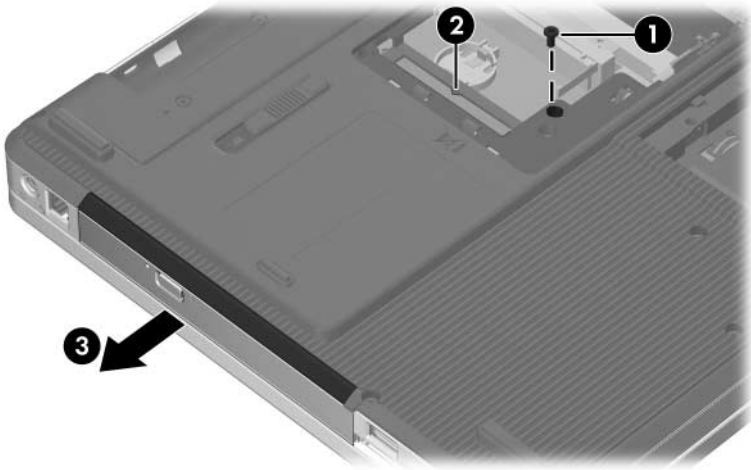
---

DVD±RW and CD-RW Double-Layer Combo Drive	413102-001
DVD/CD-RW Double-Layer Combo Drive with LightScribe	413101-001
DVD/CD-RW Combo Drive	413100-001
DVD±RW and CD-RW Super Multi Double-Layer Combo Drive	430858-001
DVD/CD-RW Super Multi Double-Layer Combo Drive with LightScribe and Hitachi LG Data Storage	430859-001
DVD/CD-RW Super Multi Double-Layer Combo Drive with LightScribe and Hitachi LG Data Storage	417699-001

---

1. Prepare the computer for disassembly ([Section 5.3](#)).
2. Position the computer with the left side toward you.

3. Remove the Phillips PM2.5×5.0 screw **1** that secures the optical drive to the computer.
4. Insert a thin tool into the notch **2** on the back of the optical drive and push to disconnect the optical drive from the system board.
5. Remove the optical drive **3**.

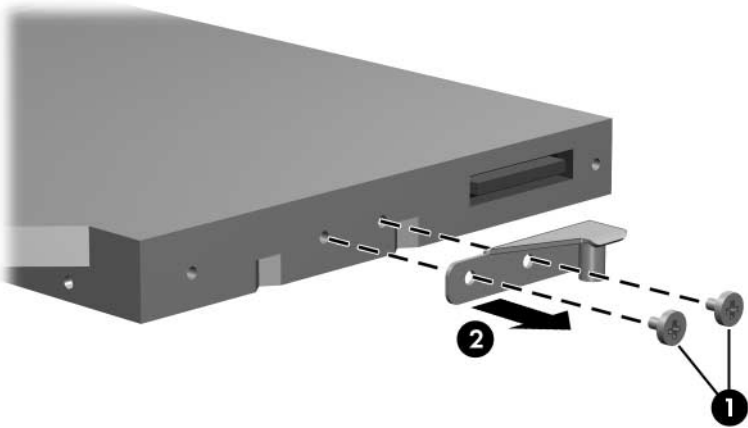


*Removing the Optical Drive*



If it is necessary to replace the optical drive bracket, perform the following steps:

6. Position the optical drive with the connector toward you.
7. Remove the two Phillips PM2.0×4.0 screws ❶ that secure the optical drive bracket to the optical drive.
8. Remove the optical drive bracket ❷.



*Removing the Optical Drive Bracket*

Reverse the above procedure to install an optical drive.

## 5.10 Switch Cover

---

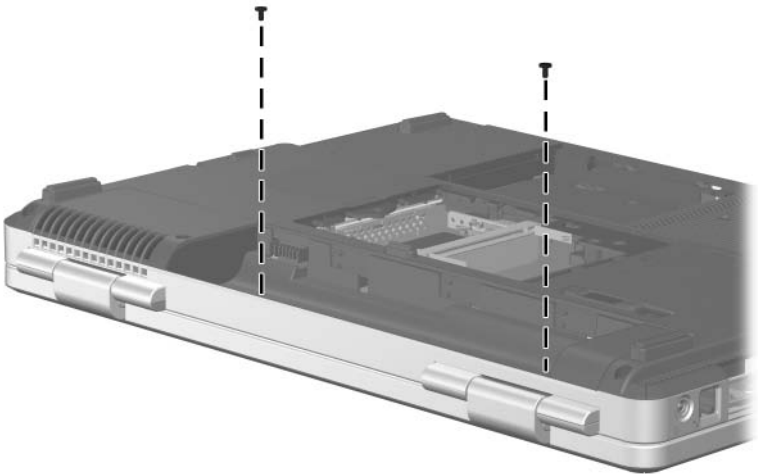
### Switch Cover Spare Part Number Information

---

For use with full-featured models	407827-001
For use with defeatured models	407828-001

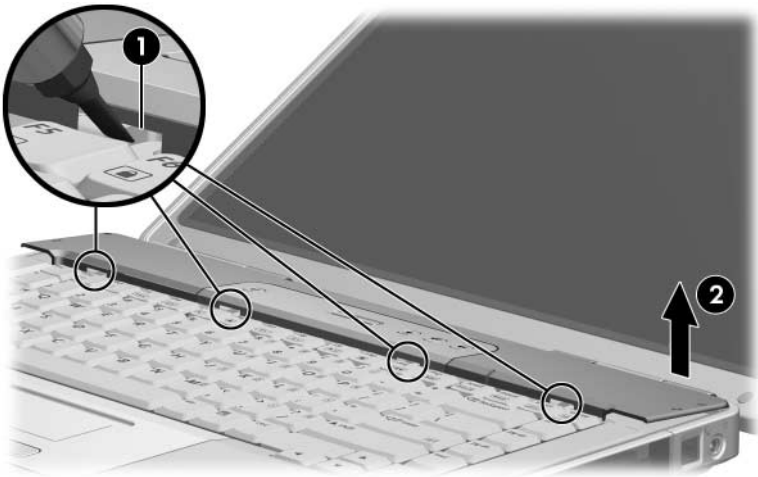
---

1. Prepare the computer for disassembly ([Section 5.3](#)).
2. Remove the two Phillips PM2.5×5.0 screws that secure the switch cover to the computer.



*Removing the Switch Cover Screws*

3. Turn the computer display-side up with front toward you.
4. Open the computer as far as possible.
5. Insert a flat-bladed tool into the switch cover notches behind the **F1**, **F5**, **F11**, and **insert** keys ❶ and lift up until the switch cover ❷ disengages from the computer.
6. Remove the switch cover.



*Removing the Switch Cover*

Reverse the above procedure to install the switch cover.

## 5.11 Keyboard

---

### Keyboard Spare Part Number Information

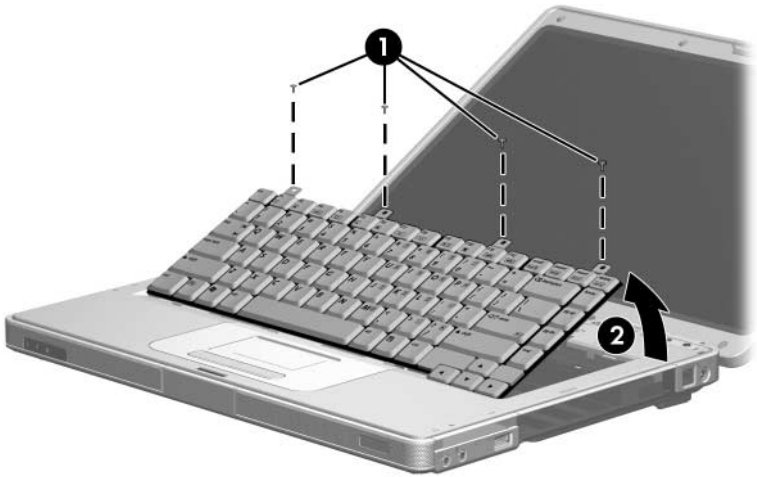
---

Denmark	407856-081	Norway	407856-091
France	407856-051	Spain	407856-071
French Canada	407856-121	Sweden/Finland	407587-B71
International	407856-B31	The United Kingdom	407856-031
Italy	407856-061	The United States	407856-001

---

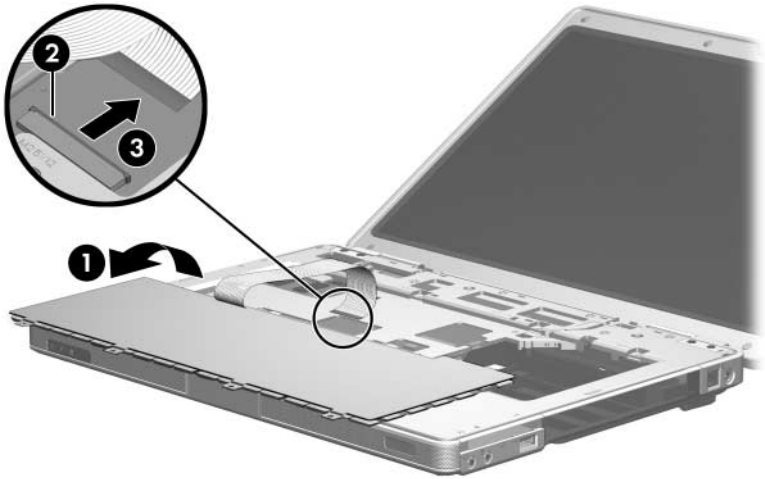
1. Prepare the computer for disassembly ([Section 5.3](#)).
2. Remove the switch cover ([Section 5.10](#)).

3. Remove the four Phillips PM2.5×5.0 screws **1** that secure the keyboard to the computer.
4. Lift the rear edge of the keyboard **2** to release it from the top cover.



*Releasing the Keyboard*

5. Swing the keyboard **1** forward until it rests on the palm rest.
6. Release the zero insertion force (ZIF) connector to which the keyboard cable **2** is attached and disconnect the keyboard cable **3**.
7. Remove the keyboard assembly.



### *Removing the Keyboard*

Reverse the above procedure to install the keyboard.

## 5.12 Display Assembly

---

### Display Assembly Spare Part Number Information

---



All display assemblies include a display cable, wireless antenna transceivers, and antenna cables.

15.4-inch, WXGA with BrightView

407842-001

15.4-inch, WXGA antiglare

407840-001

---

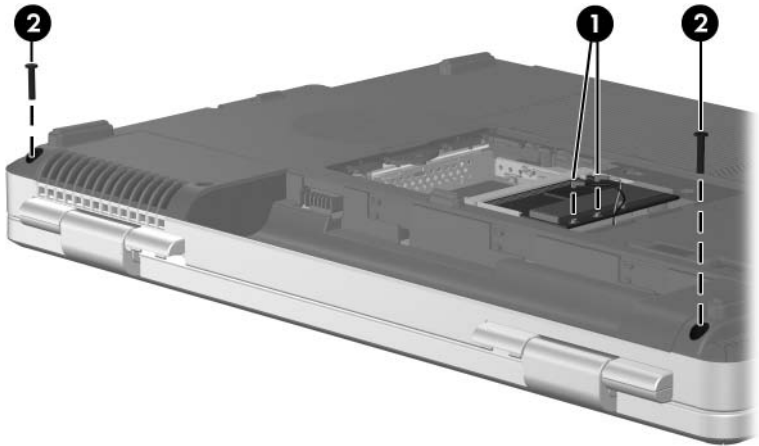
1. Prepare the computer for disassembly ([Section 5.3](#)).
2. Remove the memory/Mini PCI module compartment cover ([Section 5.6](#)).



Before disconnecting the antenna cables, make note of which cable is attached to which antenna clip on the Mini PCI communications card.

---

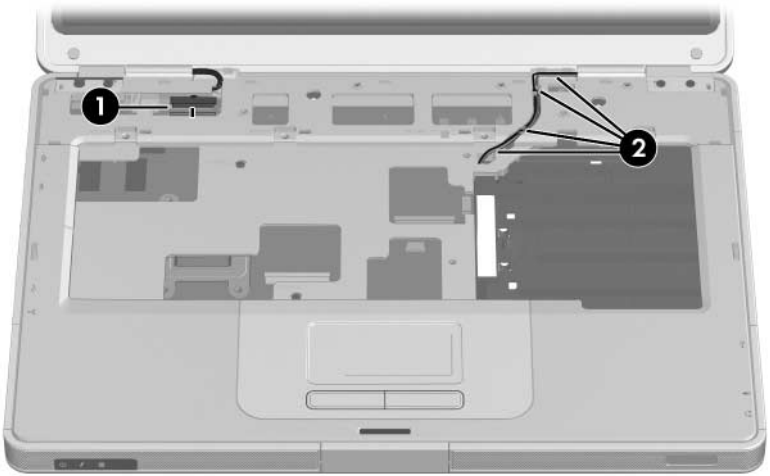
3. Disconnect the auxiliary and main antenna cables **1** from the Mini PCI communications module.
4. Remove the two Phillips PM2.5×13.0 screws **2** that secure the display assembly to the computer.



*Disconnecting the Wireless Antenna Cables and Removing the Display Screws*



5. Remove the switch cover (Section 5.10).
6. Remove the keyboard (Section 5.11).
7. Disconnect the display cable ❶ from the system board.
8. Remove the wireless antenna cables from the clips ❷ in the top cover.



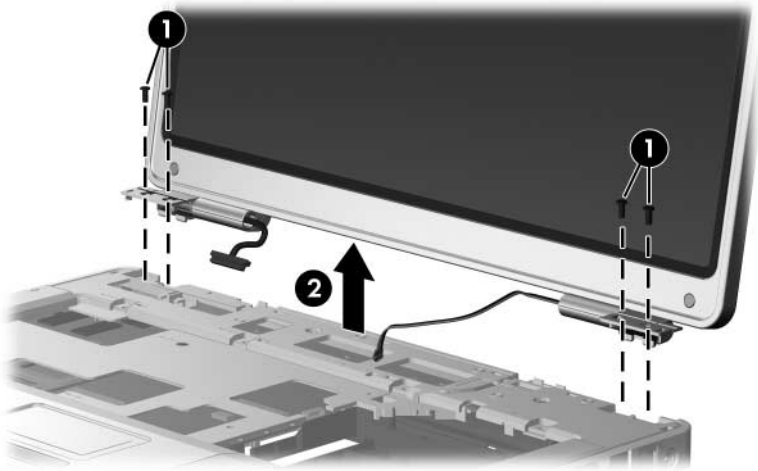
*Disconnecting the Display and Wireless Antenna Cables*



**CAUTION:** Support the display assembly when removing the following screws. Failure to support the display assembly can result in damage to the display assembly and other computer components.

---

9. Remove the four Phillips PM2.5×9.0 screws **1** that secure the display assembly to the computer.
10. Lift the display assembly straight up and remove it **2**.



*Removing the Display Assembly*

---

## Display Assembly Subcomponents

### Spare Part Number Information

---

Display Plastics Kit, includes:	407793-001
■ Display bezel	
■ Display enclosure	
■ Display hinge base covers	
■ Display hinge covers	
Display Hinge Kit, includes	407797-001
■ Display hinges	
■ Display release hook	
Display inverter board	407800-001
Display Panel Kit (includes display panel cable)	
■ 15.4-inch, WXGA with BrightView	407799-001
■ 15.4-inch, WXGA antiglare	407798-001
Wireless Antenna Kit (includes cable and transceivers)	410118-001
Display Label Kit	407865-001
Display Screw Kit, includes:	407795-001
■ Phillips PM2.5×7.0 screws	
■ Phillips PM2.5×5.0 screws	
■ Rubber screw covers	

---

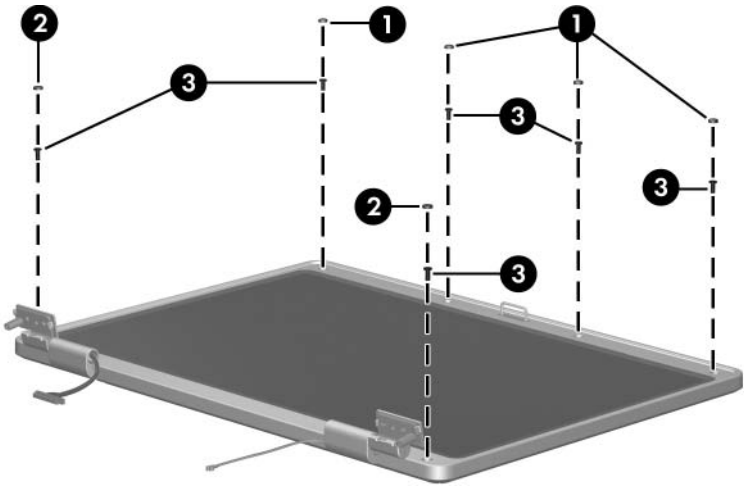
11. Remove the six rubber screw covers **1** and **2** and the six Phillips PM2.5×7.0 screws **3** that secure the display bezel to the display assembly.



The rubber screw covers are available in the Display Screw Kit, spare part number 407795-001.

The four rubber screw covers **1** on top edge of the display bezel are a different size and shape than the two rubber screw covers **2** on the bottom edge of the display bezel.

---

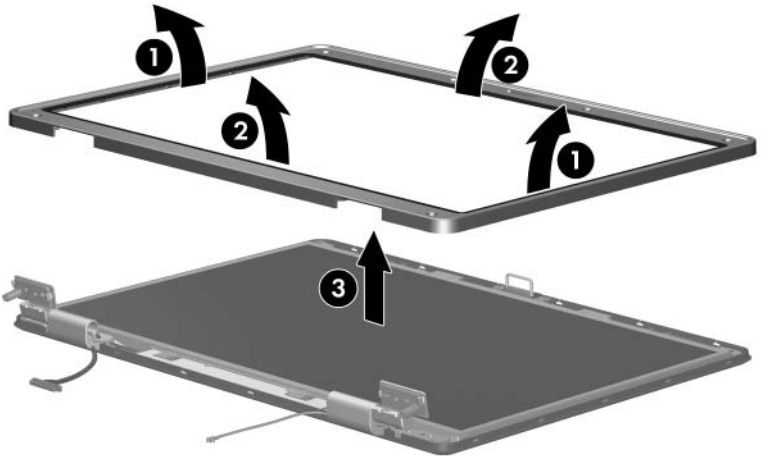


*Removing the Display Bezel Screws*



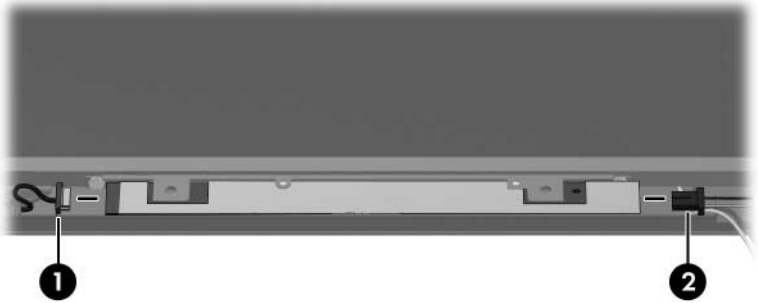
The display bezel and display enclosure are available in the Display Plastics Kit, spare part number 407793-001.

12. Flex the inside edges of the left and right sides **1** and the top and bottom sides **2** of the display bezel until the bezel disengages from the display enclosure.
13. Remove the display bezel **3**.



*Removing the Display Bezel*

14. Disconnect the display panel cable ❶ and display backlight cable ❷ from the display inverter board.



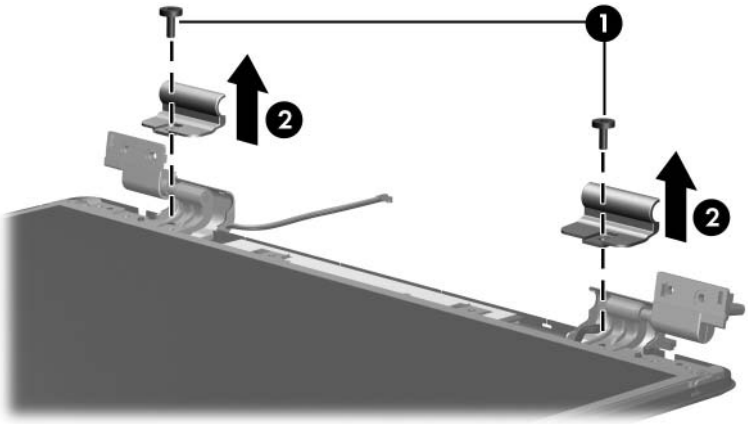
*Disconnecting the Display Panel Cables*



The display hinge base covers are available in the Display Plastics Kit, spare part number 407793-001.

---

15. If it is necessary to replace the display hinge base covers, remove the two Phillips PM2.5×5.0 screws **1** that secure the covers to the display enclosure.
16. Remove the display hinge base covers **2**.



*Removing the Display Hinge Base Covers*

---

## Display Assembly Subcomponents

### Spare Part Number Information

---

Display Panel Kit (includes display panel cable)

■ 15.4-inch, WXGA with BrightView

407799-001

■ 15.4-inch, WXGA antiglare

407798-001

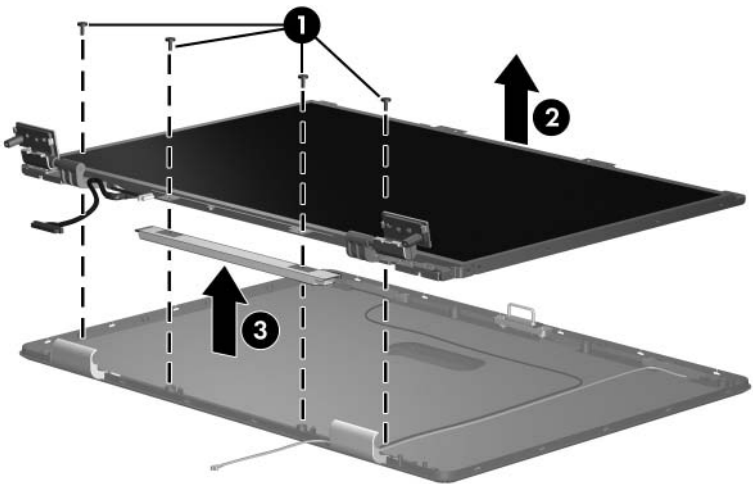
---

Display inverter board

407800-001

---

17. Remove the four Phillips PM2.5×5.0 screws **1** that secure the display panel and inverter board to the display enclosure.
18. Remove the display panel **2** and inverter board **3**.



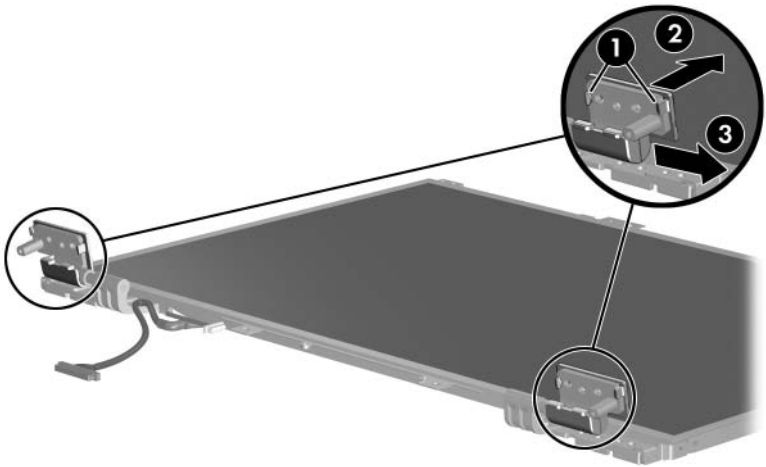
*Removing the Display Panel and Inverter Board*





The display hinge covers are available in the Display Plastics Kit, spare part number 407793-001.

19. If it is necessary to replace either of the display hinge covers, detach the display hinge cover clips **1** from the display hinge.
20. Swing the display hinge cover **2** back until it clears the display hinge.
21. Slide the hinge cover **3** off of the display hinge.



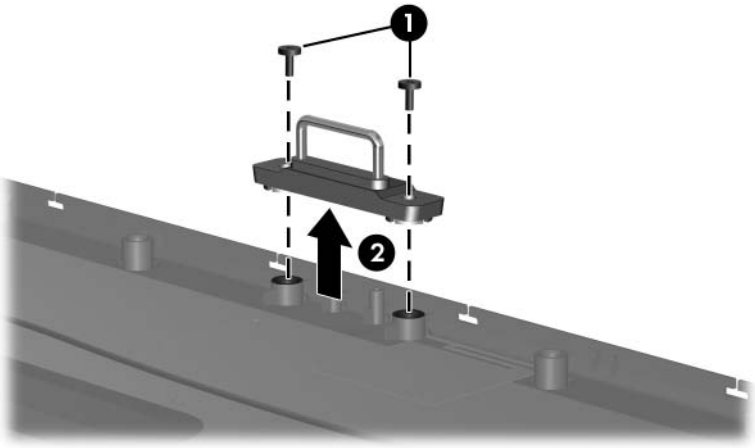
*Removing the Display Hinge Covers*



The display release hook is available in the Display Hinge Kit, spare part number 407797-001.

---

22. If it is necessary to replace the display release hook, remove the two PM2.5×5.0 screws **1** that secure the hook to the display enclosure.
23. Remove the display release hook **2**.



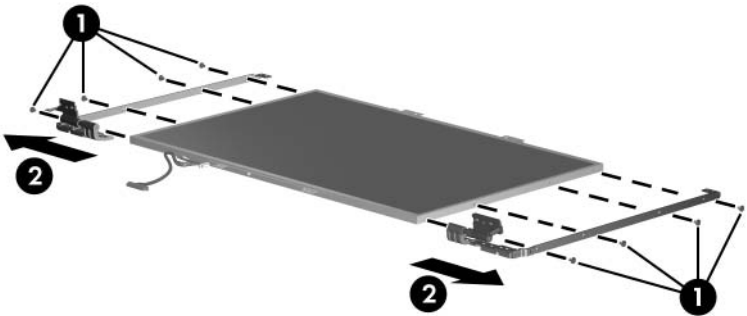
*Removing the Display Release Hook*



The display hinges are available in the Display Hinge Kit, spare part number 407797-001.

---

24. If it is necessary to replace the display hinges, remove the four Phillips PM2.0x4.0 screws **1** that secure each hinge to the display panel.
25. Remove the display hinges **2**.



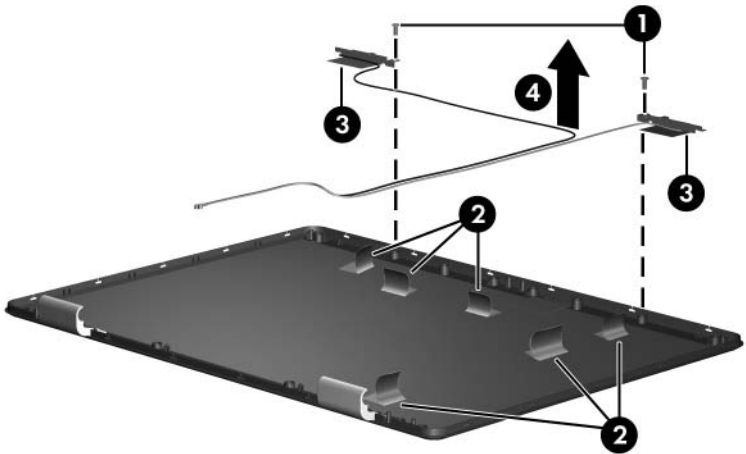
*Removing the Display Hinges*



The wireless antenna transceivers and cables are available in the Wireless Antenna Kit, spare part number 410118-001.

---

26. If it is necessary to replace the wireless antenna transceivers and cables, remove the Phillips PM2.5×5.0 screws ❶ that secure the wireless antenna transceivers to the display enclosure.
27. Release the retention tabs ❷ built in to the display enclosure lining that secure the wireless antenna cables to the display enclosure.
28. Detach the wireless antenna transceivers ❸ from the display enclosure.
29. Remove the wireless antenna transceivers and cables ❹.



*Removing the Wireless Antenna Transceivers and Cables*

Reverse the above procedure to reassemble and install the display assembly.

## 5.13 Base Enclosure

---

### Base Enclosure and Top Cover Spare Part Number Information

---

Base enclosure for use with full-featured models	415493-001
Base enclosure for use with defeatured models	415494-001
Top cover for use with full-featured models	407823-001
Top cover for use with defeatured models	407824-001

---

1. Prepare the computer for disassembly ([Section 5.3](#)) and then remove the following components:
  - a. Hard drive ([Section 5.4](#))
  - b. Memory/Mini PCI module compartment cover ([Section 5.6](#))
  - c. Optical drive ([Section 5.9](#))
  - d. Switch cover ([Section 5.10](#))
  - e. Keyboard ([Section 5.11](#))
  - f. Display assembly ([Section 5.12](#))

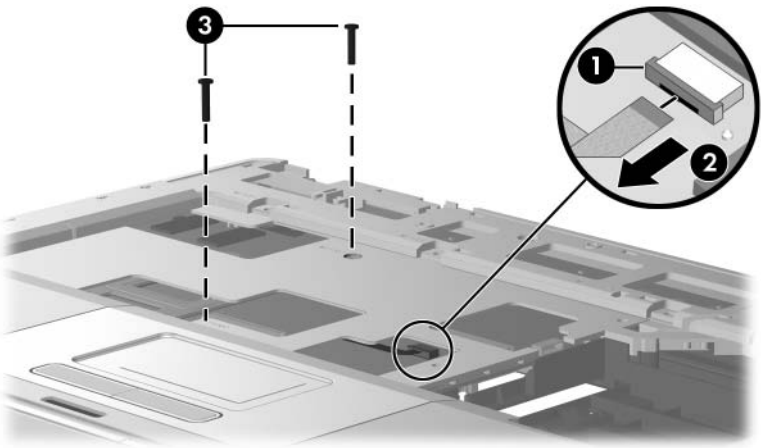
2. Release the ZIF connector to which the TouchPad cable ❶ is connected and disconnect the TouchPad cable ❷ from the system board.



The TouchPad cable is included in the Cable Kit, spare part number 407775-001.

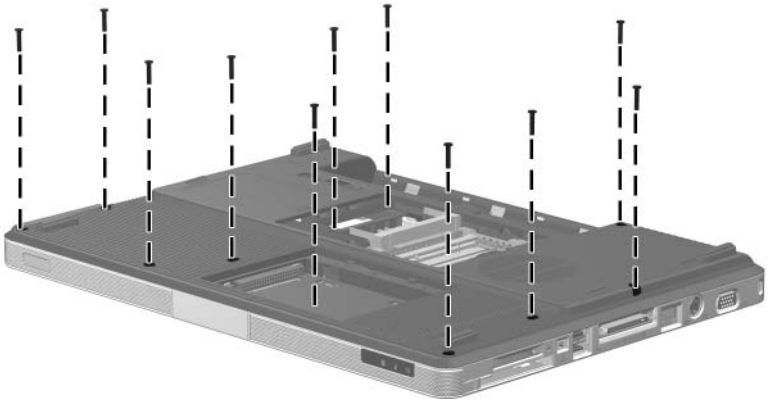
---

3. Remove the two Phillips PM2.5×13.0 screws ❸ that secure the base enclosure to the computer.



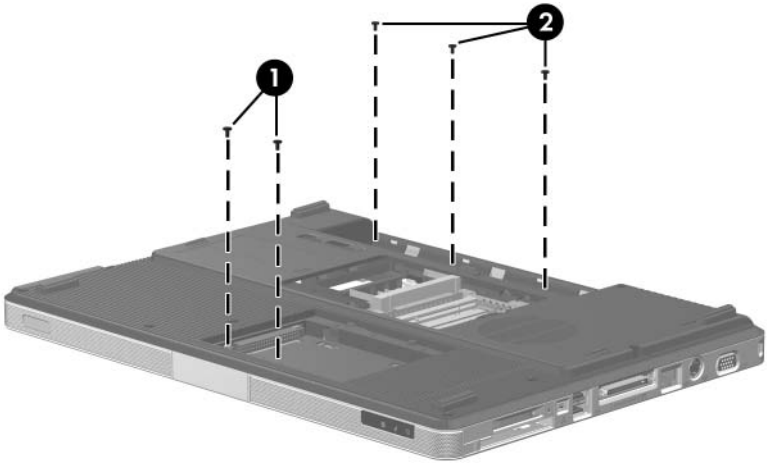
*Disconnecting the TouchPad Cable and Removing the Base Enclosure Screws, Part 1*

4. Turn the computer upside down with the front toward you.
5. Remove the eleven Phillips PM2.5×13.0 screws that secure the base enclosure to the computer.



*Removing the Base Enclosure Screws, Part 2*

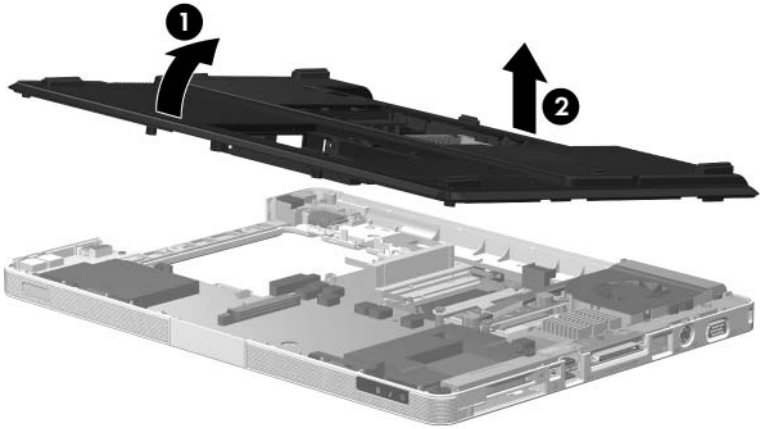
6. Remove the two Phillips PM2.5×5.0 screws ❶ in the hard drive bay and the three Phillips PM2.5×5.0 screws ❷ in the battery bay that secure the base enclosure to the computer.



*Removing the Base Enclosure Screws, Part 3*



7. Lift up the front edge of the base enclosure ❶ until it disengages from the top cover.
8. Lift the base enclosure ❷ straight up and remove it.



*Removing the Base Enclosure*

Reverse the above procedure to install the base enclosure.

## 5.14 Bluetooth Module

---

### Bluetooth Module Spare Part Number Information

---

Bluetooth module (includes Bluetooth module cable)	397922-001
--	------------

---

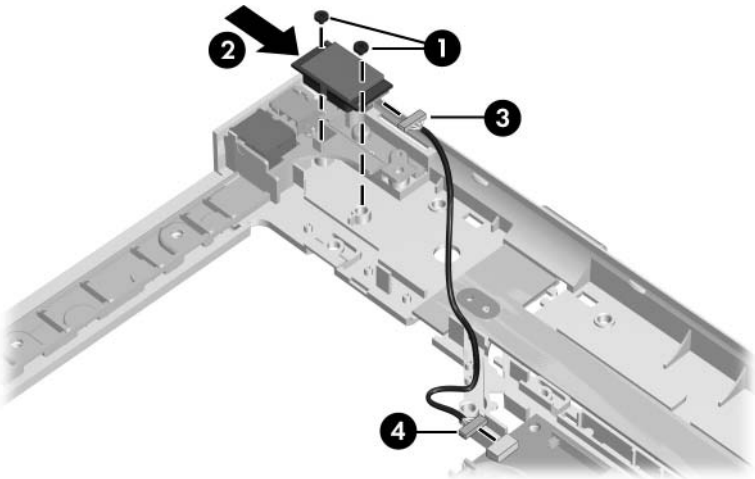
1. Prepare the computer for disassembly ([Section 5.3](#)), and then remove the following components:
  - a. Hard drive ([Section 5.4](#))
  - b. Memory/Mini PCI module compartment cover ([Section 5.6](#))
  - c. Optical drive ([Section 5.9](#))
  - d. Switch cover ([Section 5.10](#))
  - e. Keyboard ([Section 5.11](#))
  - f. Display assembly ([Section 5.12](#))
  - g. Base enclosure ([Section 5.13](#))

2. Remove the two Phillips PM1.5×3.0 screws **1** that secure the Bluetooth module to the top cover.
3. Slide the Bluetooth module **2** out of the clip in the top cover.
4. Disconnect the Bluetooth module cable **3** from the Bluetooth module.
5. Disconnect the Bluetooth module cable **4** from the system board.



The Bluetooth module cable is included with the Bluetooth module and is also available in the Cable Kit, spare part number 407775-001.

---



### *Removing the Bluetooth Module*

Reverse the above procedure to install the Bluetooth module.

## 5.15 System Board

---

### System Board Spare Part Number Information

---

For use with defeatured models	430150-001
For use with full-featured models	430151-001

---

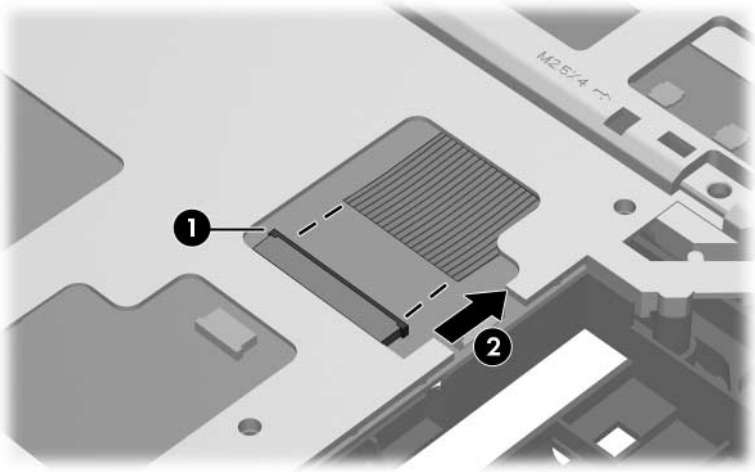


When replacing the system board, ensure that the following components are removed from the defective system board and installed on the replacement system board:

- Memory modules ([Section 5.6](#))
  - Mini PCI communications module ([Section 5.7](#))
  - RTC battery ([Section 5.8](#))
  - Power connector cable ([Section 5.15](#))
  - Heat sink ([Section 5.18](#))
  - Processor ([Section 5.19](#))
  - Fan assembly ([Section 5.20](#))
  - Fan assembly ([Section 5.20](#))
  - PC Card assembly ([Section 5.21](#))
- 

1. Prepare the computer for disassembly ([Section 5.3](#)), and then remove the following components:
  - a. Hard drive ([Section 5.4](#))
  - b. Memory/Mini PCI module compartment cover ([Section 5.6](#))
  - c. Optical drive ([Section 5.9](#))
  - d. Switch cover ([Section 5.10](#))
  - e. Keyboard ([Section 5.11](#))
  - f. Display assembly ([Section 5.12](#))
  - g. Base enclosure ([Section 5.13](#))

2. Turn the top cover right-side up with the front toward you.
3. Release the ZIF connector ❶ to which the LED board cable is connected and disconnect the LED board cable ❷ from the system board.



*Disconnecting the LED Board Cable*

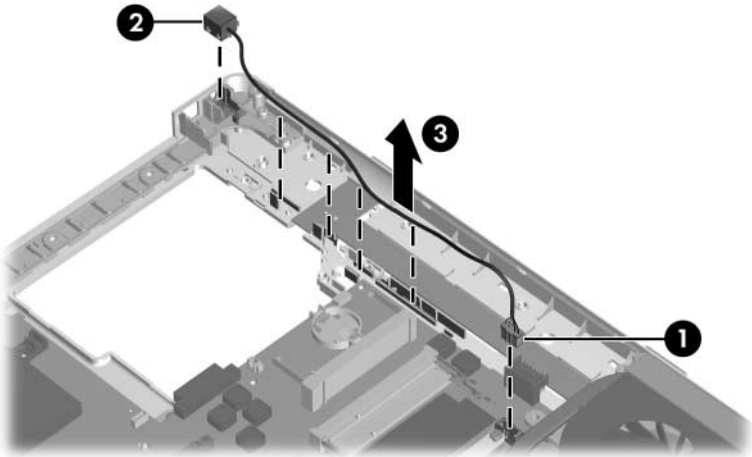
4. Turn the top cover upside down with the front toward you.
5. Disconnect the power connector cable ❶ from the system board.



The power connector cable is included with the Cable Kit, spare part number 407775-001, and is also available using spare part number 415564-001.

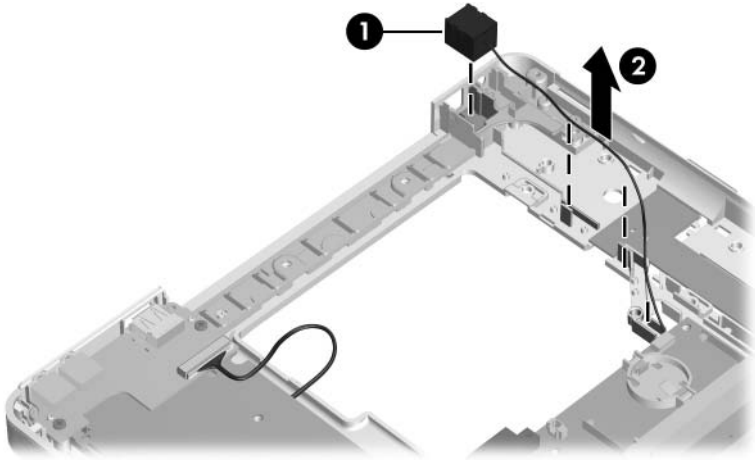
---

6. Remove the power connector ❷ from the clip in the base enclosure and remove the cable from the routing channel ❸ in the top cover.



*Removing the Power Connector Cable*

7. Remove the modem connector **1** from the clip in the top cover and remove the modem connector cable **2** from the routing channel in the top cover.



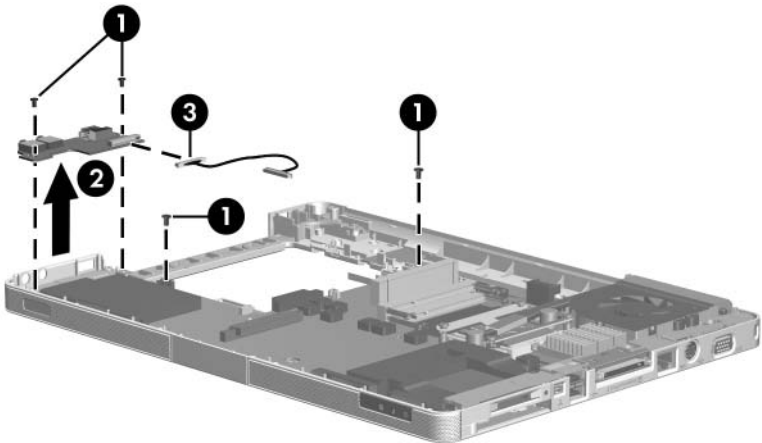
*Removing the Modem Connector Cable*

8. Disconnect the USB/audio board cable **1** from the USB/audio board.
9. Remove the four PM2.5×5.0 screws **2** that secure the system board and USB/audio board to the top cover.
10. Remove the USB/audio board **3** from the top cover.



The USB/audio board is available using spare part numbers 417027-001 (for use with full-featured models) and 417028-001 (for use with defeatured models). The USB/audio board cable is included with the USB/audio board and is also available in the Cable Kit, spare part number 407775-001.

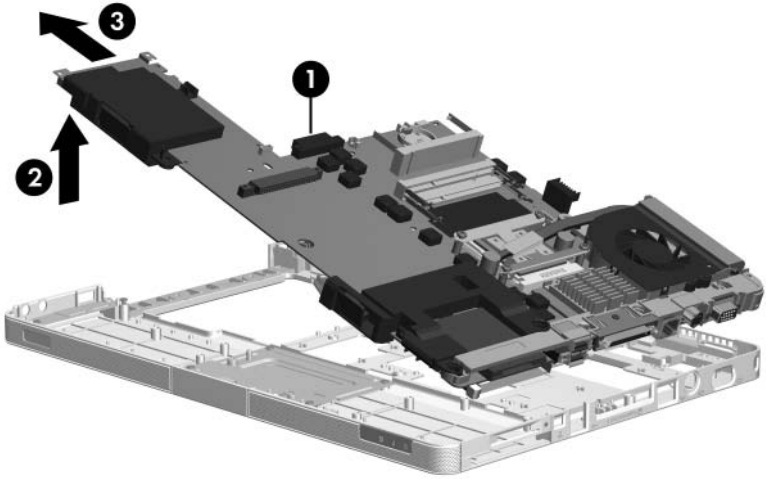
---



*Removing the USB/Audio Board*



11. Use the optical drive connector **1** to lift the left side of the system board **2** until it clears the top cover.
12. Slide the system board **3** to the left at an angle and remove it.



*Removing the System Board*

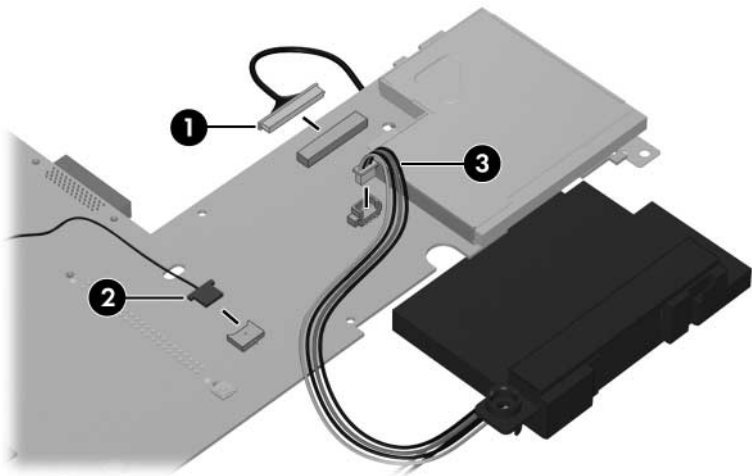
13. Position the system board with the ExpressCard and PC Card assemblies facing up and the battery connector toward you.
14. Disconnect the following cables from the system board:
  - ❶ USB/audio board cable
  - ❷ Modem cable
  - ❸ Speaker cable



The USB/audio board cable is included with the USB/audio board and is also available in the Cable Kit, spare part number 407775-001.

The modem connector cable is available in the Cable Kit, spare part number 407775-001.

---



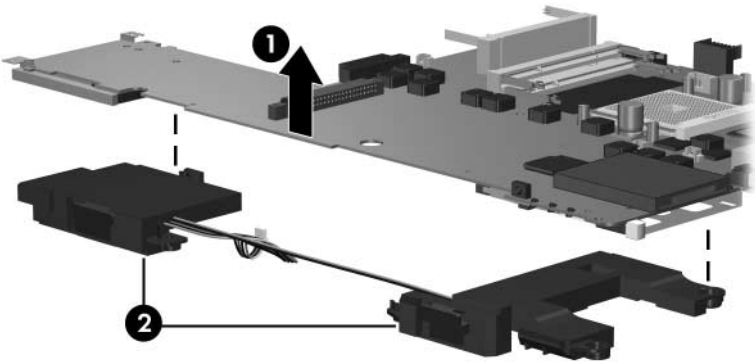
*Disconnecting the USB/Audio Board, Speaker, and Modem Cables*

15. Set the USB/audio board cable and modem connector cable aside.
16. Lift the system board ❶ and separate the speakers ❷ from the system board.



The speakers are available using spare part number 407785-001.

---



#### *Removing the Speakers*

Reverse the above procedure to install the system board.

## 5.16 Display Release Button

---



The display release button components are spared with the top cover.

---

1. Prepare the computer for disassembly ([Section 5.3](#)) and then remove the following components:
  - a. Hard drive ([Section 5.4](#))
  - b. Memory/Mini PCI module compartment cover ([Section 5.6](#))
  - c. Optical drive ([Section 5.9](#))
  - d. Switch cover ([Section 5.10](#))
  - e. Keyboard ([Section 5.11](#))
  - f. Display assembly ([Section 5.12](#))
  - g. Base enclosure ([Section 5.13](#))

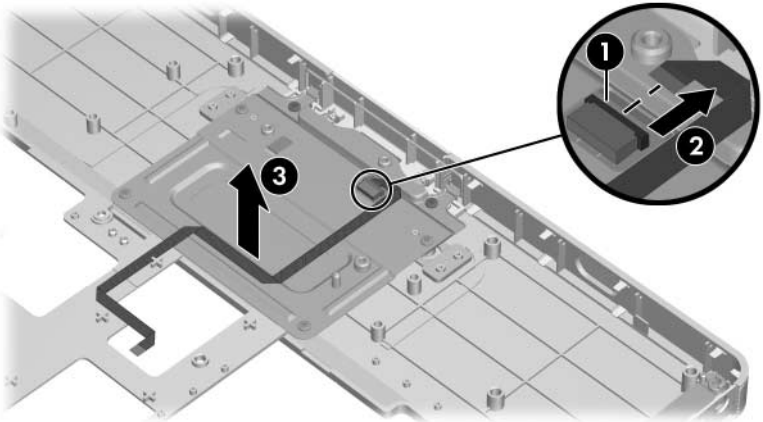
2. Release the ZIF connector **1** on the TouchPad board to which the TouchPad cable is connected.
3. Disconnect the TouchPad cable **2** from the TouchPad board.



The TouchPad cable is included in the Cable Kit, spare part number 407775-001.

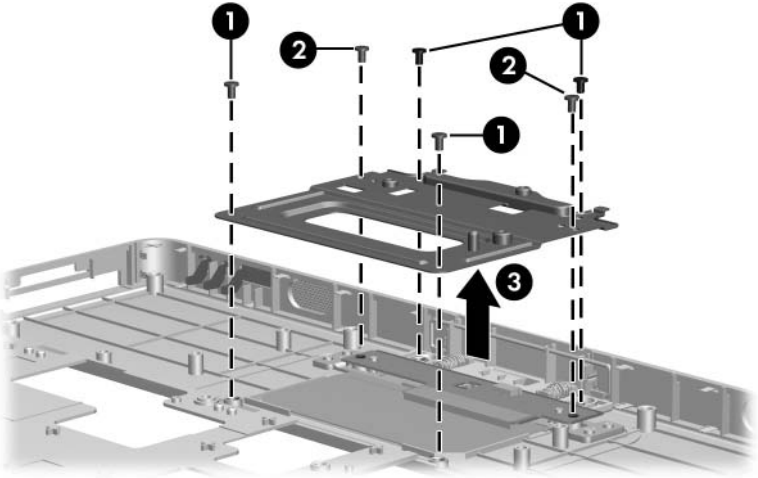
---

4. Remove the TouchPad cable **3**.



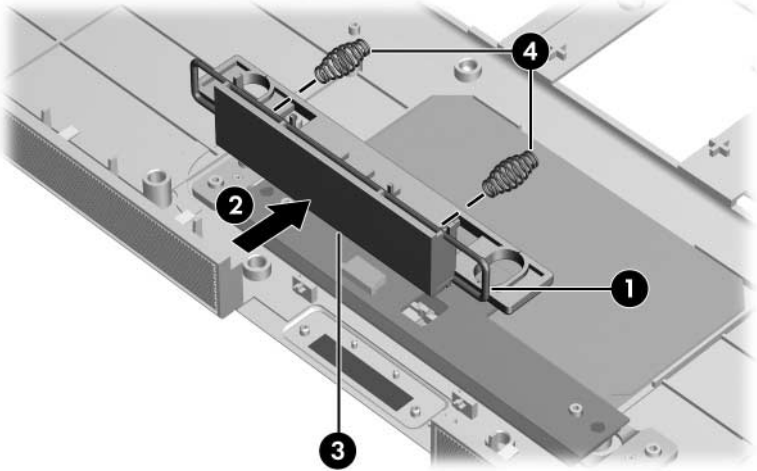
*Removing the TouchPad Cable*

5. Remove the four silver Phillips PM2.5×4.0 screws ❶ and the two Phillips PM2.5×5.0 screws ❷ that secure the TouchPad bracket to the top cover.
6. Remove the TouchPad bracket ❸.



*Removing the TouchPad Bracket*

7. Remove the display release button swing arm **1** from the top cover.
8. Push and hold the display release button **2**.
9. Remove the display release button **3** and springs **4** from the top cover.



*Removing the Display Release Button Components*

Reverse the above procedure to install the display release button.

## 5.17 LED Board

---

### LED Board Spare Part Number Information

---

LED board (includes LED board cable)

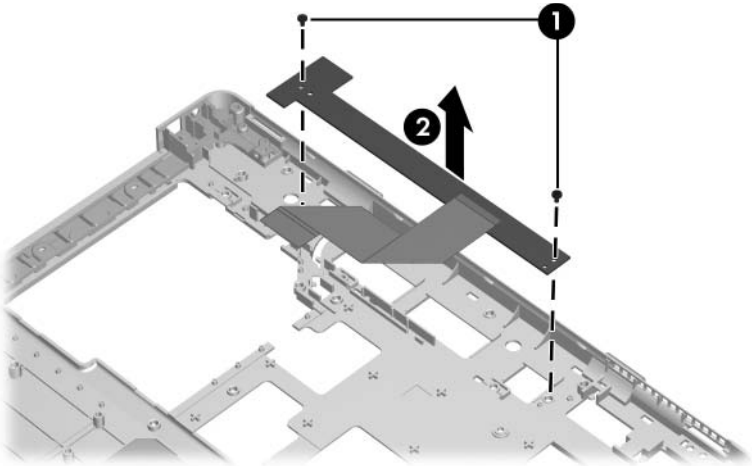
417024-001

---

1. Prepare the computer for disassembly ([Section 5.3](#)), and then remove the following components:
  - a. Hard drive ([Section 5.4](#))
  - b. Memory/Mini PCI module compartment cover ([Section 5.6](#))
  - c. Optical drive ([Section 5.9](#))
  - d. Switch cover ([Section 5.10](#))
  - e. Keyboard ([Section 5.11](#))
  - f. Display assembly ([Section 5.12](#))
  - g. Base enclosure ([Section 5.13](#))
  - h. System board ([Section 5.15](#))



2. Remove the two Phillips PM2.5×5.0 screws ❶ that secure the LED board to the top cover.
3. Remove the LED board and cable ❷.



*Removing the LED Board*

Reverse the above procedure to install the LED board.

## 5.18 Heat Sink

---

### Heat Sink Spare Part Number Information

---

Heat sink (includes thermal paste)	403827-001
Thermal paste	407817-001

---

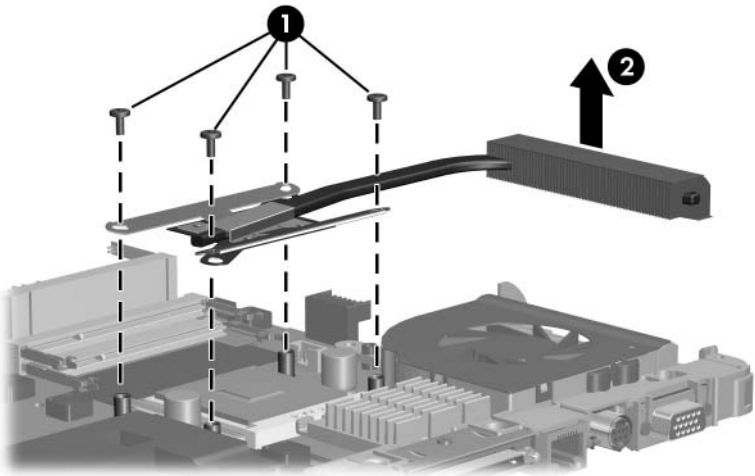
1. Prepare the computer for disassembly ([Section 5.3](#)), and then remove the following components:
  - a. Hard drive ([Section 5.4](#))
  - b. Memory/Mini PCI module compartment cover ([Section 5.6](#))
  - c. Optical drive ([Section 5.9](#))
  - d. Switch cover ([Section 5.10](#))
  - e. Keyboard ([Section 5.11](#))
  - f. Display assembly ([Section 5.12](#))
  - g. Base enclosure ([Section 5.13](#))
  - h. System board ([Section 5.15](#))

2. Turn the system board upside down with the expansion port 2 toward you.
3. Remove the four Phillips PM2.5×7.0 screws ❶ that secure the heat sink to the system board.
4. Remove the heat sink ❷.



Due to the adhesive quality of the thermal paste located between the fan assembly and processor, it may be necessary to move the fan assembly from side to side to detach it from the processor.

---

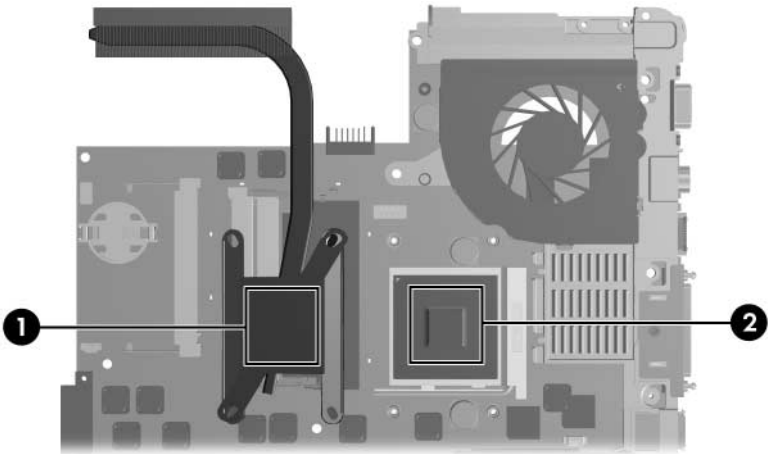


*Removing the Heat Sink*



The thermal paste should be thoroughly cleaned from the surfaces of the heat sink **1** and processor **2** each time the heat sink is removed. Thermal paste should be reapplied to both surfaces before the heat sink is reinstalled. Thermal paste is included with all heat sink and processor spare part kits.

---



### *Replacing the Thermal Paste*

Reverse the above procedure to install the fan assembly.

## 5.19 Processor



The computer may be equipped with a processor socket that features either a locking screw or a release arm. Both types of sockets are documented in this section.

### Processor Spare Part Number Information



All processor spare part kits include thermal paste.

AMD Turion 64 ML-40 (2.2-GHz)	430499-001
AMD Turion 64 ML-40 (2.2-GHz)	393579-001
AMD Turion 64 ML-37 (2.0-GHz)	393578-001
AMD Turion 64 ML-34 (1.8-GHz)	407836-001
AMD Turion 64 ML-32 (1.8-GHz)	395744-001
Mobile AMD Sempron M3300 (2.0-GHz)	407837-001
Mobile AMD Sempron M3100 (1.8-GHz)	430855-001
Mobile AMD Sempron M3000 (1.8-GHz)	407838-001
Thermal paste	407817-001

1. Prepare the computer for disassembly ([Section 5.3](#)), and then remove the following components:
  - a. Hard drive ([Section 5.4](#))
  - b. Memory/Mini PCI module compartment cover ([Section 5.6](#))
  - c. Optical drive ([Section 5.9](#))
  - d. Switch cover ([Section 5.10](#))
  - e. Keyboard ([Section 5.11](#))
  - f. Display assembly ([Section 5.12](#))
  - g. Base enclosure ([Section 5.13](#))
  - h. System board ([Section 5.15](#))
  - i. Heat sink ([Section 5.18](#))



Steps 2 and 3 apply to processor sockets equipped with a locking screw. Refer to steps 4 through 6 for instructions on removing a processor from a socket equipped with a release arm.

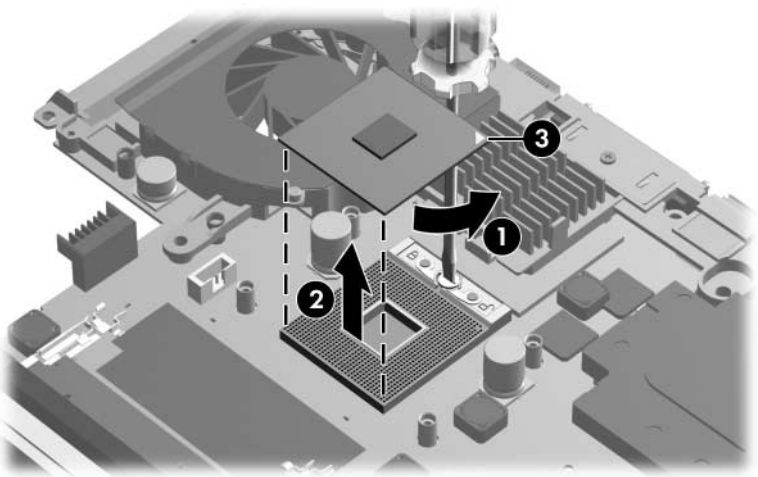
---

2. Use a flat-bladed screwdriver to turn the processor locking screw **1** one-quarter turn counterclockwise until you hear a click.
  3. Lift the processor straight up and remove it **2**.
- 



The gold triangle **3** on the processor should be aligned in the front right corner when you install the processor.

---



*Removing the Processor from a Socket with a Locking Screw*



Steps 4 through 6 apply to processor sockets equipped with a release arm.

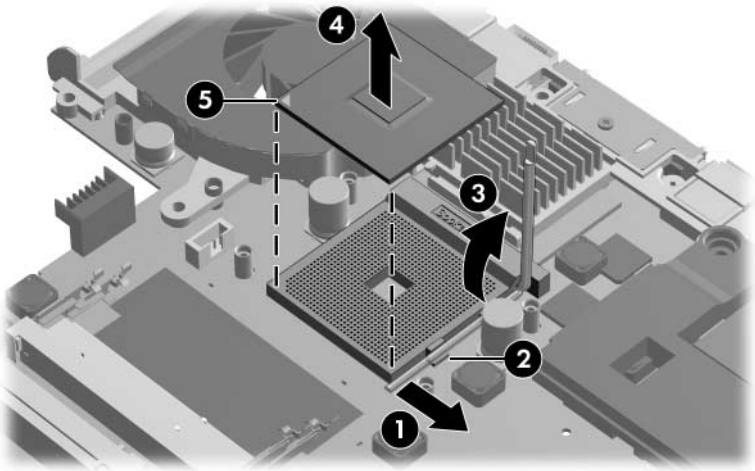
---

4. Slide the tip of the processor socket release arm **1** to the left until it clears the notch **2** on the processor socket.
  5. Swing the processor socket release arm **3** up and forward as far as it will go.
  6. Lift the processor straight up and remove it **4**.
- 



The gold triangle **5** on the processor should be aligned in the front right corner when you install the processor.

---



*Removing the Processor from a Socket with a Release Arm*

Reverse the above procedure to install the processor.



## 5.20 Fan Assembly

---

### Fan Assembly Spare Part Number Information

---

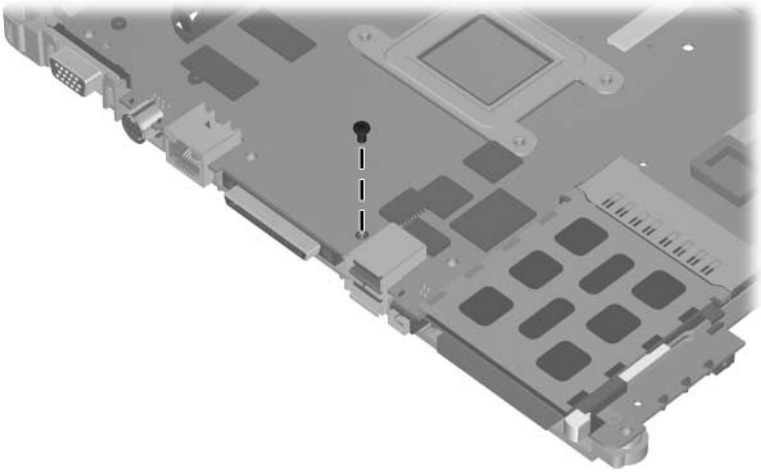
Fan assembly

407808-001

---

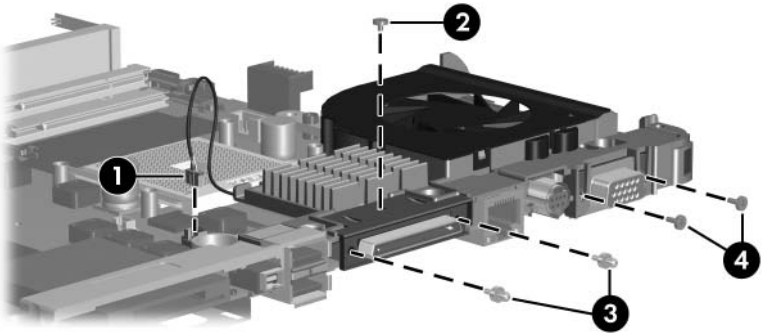
1. Prepare the computer for disassembly ([Section 5.3](#)), and then remove the following components:
  - a. Hard drive ([Section 5.4](#))
  - b. Memory/Mini PCI module compartment cover ([Section 5.6](#))
  - c. Optical drive ([Section 5.9](#))
  - d. Switch cover ([Section 5.10](#))
  - e. Keyboard ([Section 5.11](#))
  - f. Display assembly ([Section 5.12](#))
  - g. Base enclosure ([Section 5.13](#))
  - h. System board ([Section 5.15](#))
  - i. Heat sink ([Section 5.18](#))

2. Turn the system board upside down with the expansion port 2 docking connector toward you.
3. Remove the Phillips PM2.0×4.0 screw that secures the fan assembly to the system board.



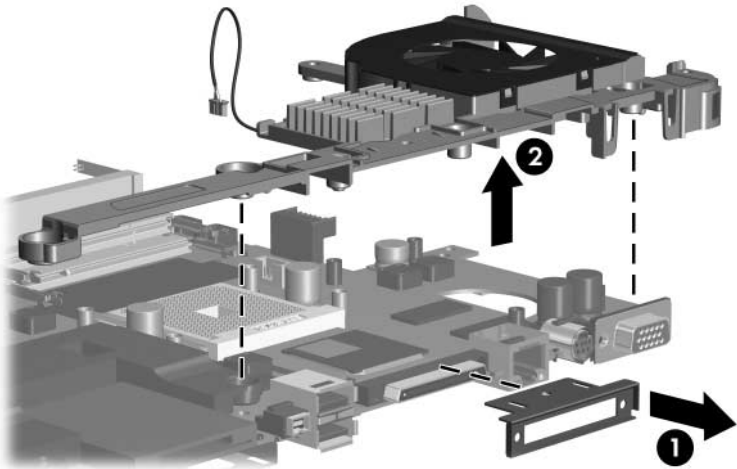
*Removing the Fan Assembly Screw, Part 1*

4. Turn the system board right-side up with the expansion port 2 docking connector toward you.
5. Disconnect the fan cable ❶ from the system board.
6. Remove the following screws:
  - ❷ One silver Phillips PM2.5×4.0 screw that secures the expansion port 2 bracket and fan assembly to the system board
  - ❸ Two slotted M1.5×9.0 screws on each side of the expansion port 2 connector that secure the expansion port bracket and fan assembly to the system board
  - ❹ Two Phillips PM3.0×6.0 screws on each side of the external monitor connector that secure the fan assembly to the system board



Removing the Fan Assembly Screws, Part 2

7. Slide the expansion port bracket **1** away from the system board.
8. Remove the fan assembly **2**.



*Removing the Fan Assembly*

Reverse the above procedure to install the fan assembly.

## 5.21 PC Card Assembly

---

### PC Card Assembly Spare Part Number Information

---

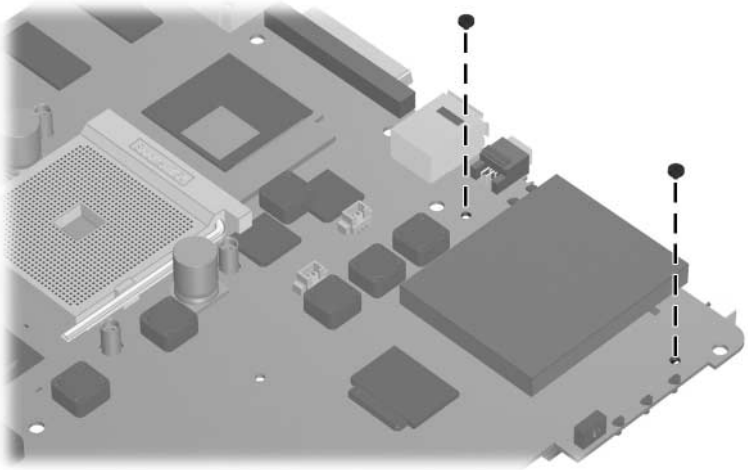
PC Card assembly

407829-001

---

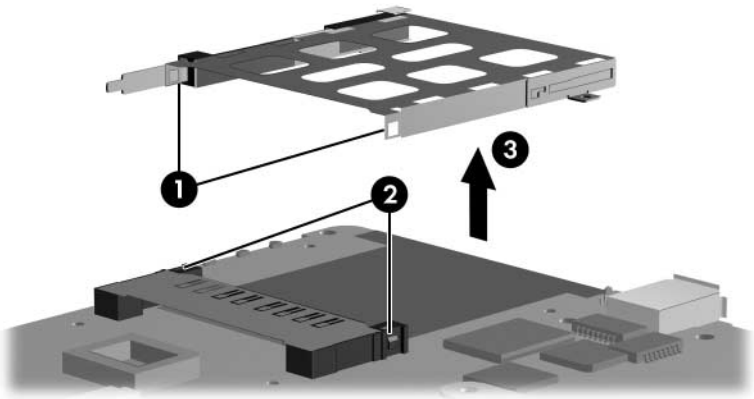
1. Prepare the computer for disassembly ([Section 5.3](#)), and then remove the following components:
  - a. Hard drive ([Section 5.4](#))
  - b. Memory/Mini PCI module compartment cover ([Section 5.6](#))
  - c. Optical drive ([Section 5.9](#))
  - d. Switch cover ([Section 5.10](#))
  - e. Keyboard ([Section 5.11](#))
  - f. Display assembly ([Section 5.12](#))
  - g. Base enclosure ([Section 5.13](#))
  - h. System board ([Section 5.15](#))

2. Turn the system board upside down with the expansion port 2 toward you.
3. Remove the two PM2.0×4.0 screws that secure the PC Card assembly to the system board.



*Removing the PC Card Assembly Screws*

4. Turn the system board top-side up with the expansion port 2 toward you.
5. Disengage the hooks **1** on the PC Card assembly from the slots on the PC Card connector **2** and remove the PC Card assembly **3** from the system board.



*Removing the PC Card Assembly*

Reverse the above procedures to install the PC Card assembly.

## 5.22 ExpressCard Assembly

---

### ExpressCard Assembly Spare Part Number Information

---

ExpressCard assembly

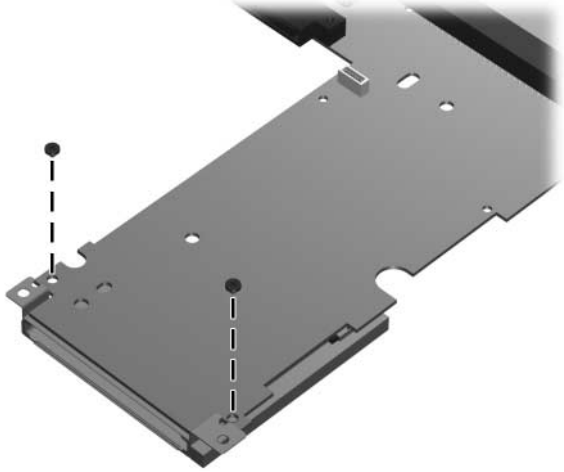
407810-001

---

1. Prepare the computer for disassembly ([Section 5.3](#)), and then remove the following components:
  - a. Hard drive ([Section 5.4](#))
  - b. Memory/Mini PCI module compartment cover ([Section 5.6](#))
  - c. Optical drive ([Section 5.9](#))
  - d. Switch cover ([Section 5.10](#))
  - e. Keyboard ([Section 5.11](#))
  - f. Display assembly ([Section 5.12](#))
  - g. Base enclosure ([Section 5.13](#))
  - h. System board ([Section 5.15](#))

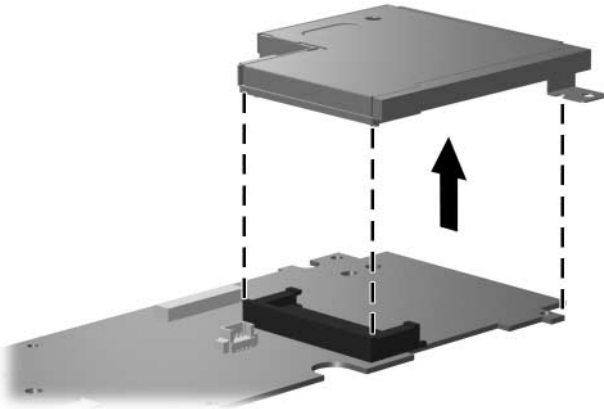


2. Turn the system board upside down with the expansion port 2 toward you.
3. Remove the two PM2.0×4.0 screws that secure the ExpressCard assembly to the system board.



*Removing the ExpressCard Assembly Screws*

4. Turn the system board top-side up with the expansion port 2 toward you.
5. Remove the ExpressCard Assembly from the system board.



*Removing the ExpressCard Assembly*

Reverse the above procedures to install the ExpressCard assembly.

# 6

## Specifications


This chapter provides physical and performance specifications.

**Table 6-1**  
**Computer**

<b>Dimensions</b>	<b>Metric</b>	<b>U.S.</b>
Height		
Front	3.50 cm	1.38 in.
Rear	4.50 cm	1.77 in.
Width	35.79 cm	14.09 in.
Depth	26.39 cm	10.39 in.
<b>Weight</b>		
With 17.0-inch display, optical drive and 8-cell battery	2.99 kg	6.60 lbs
<b>Input Power</b>		
Operating voltage	18.5 V dc to 19.0 V dc	
Operating current	3.5 A or 4.74 A	
<b>Temperature</b>		
Operating	10°C to 35°C	50°F to 95°F
Nonoperating	-20°C to 60°C	-4°F to 140°F

**Table 6-1**  
**Computer (Continued)**

<b>Relative humidity</b> (noncondensing)		
Operating	10% to 90%	10% to 90%
Nonoperating	5% to 95%	5% to 95%
<b>Maximum altitude</b> (unpressurized)		
Operating (14.7 to 10.1 psia)	-15 m to 3,048 m	-50 ft to 10,000 ft
Nonoperating (14.7 to 4.4 psia)	-15 m to 12,192 m	-50 ft to 40,000 ft
<b>Shock</b>		
Operating	125 g, 2 ms, half-sine	
Nonoperating	200 g, 2 ms, half-sine	
<b>Random Vibration</b>		
Operating	0.75 g zero-to-peak, 10 Hz to 500 Hz, 0.25 oct/min sweep rate	
Nonoperating	1.50 g zero-to-peak, 10 Hz to 500 Hz, 0.5 oct/min sweep rate	

 Applicable product safety standards specify thermal limits for plastic surfaces. The computer operates well within this range of temperatures.

**Table 6-2**  
**15.4-inch, WXGA, Display**

<b>Dimensions</b>		
Height	20.7 cm	8.15 in
Width	33.1 cm	13.03 in
Diagonal	39.1 cm	15.39 in
<b>Number of colors</b>	Up to 16.8 million	
<b>Contrast ratio</b>	200:1	
<b>Brightness</b>	180 nits typical	
<b>Pixel resolution</b>		
Pitch	0.259 × 0.259 mm	
Format	1280 × 800	
Configuration	RGB vertical stripe	
<b>Backlight</b>	Edge lit	
<b>Character display</b>	80 × 25	
<b>Total power consumption</b>	4 W	
<b>Viewing angle</b>	+/-65° horizontal, +50° vertical typical	

**Table 6-3**  
**Hard Drives**

	120-GB*	100-GB*	80-GB*
<b>Dimensions</b>			
Height	9.5 mm	9.5 mm	9.5 mm
Width	70 mm	70 mm	70 mm
Weight	102 g	102 g	99 g
<b>Interface type</b>			
	ATA-5	ATA-5	ATA-5
<b>Transfer rate</b>			
Synchronous (maximum)	100 MB/sec	100 MB/sec	100 MB/sec
Security	ATA security	ATA security	ATA security
<b>Seek times</b> (typical read, including setting)			
Single track	3 ms	3 ms	3 ms
Average	13 ms	13 ms	13 ms
Maximum	24 ms	24 ms	24 ms
<b>Logical blocks</b> <sup>†</sup>			
	234,428,430	195,364,233	156,301,488
<b>Disc rotational speed</b>			
	4200 rpm	4200 rpm	5400 rpm
<b>Operating temperature</b>			
	5°C to 55°C (41°F to 131°F)		




Certain restrictions and exclusions apply. Consult Customer Care for details.

\*1 GB = 1 billion bytes when referring to hard drive storage capacity. Actual accessible capacity is less.

<sup>†</sup>Actual drive specifications may differ slightly.

**Table 6-3**  
**Hard Drives (Continued)**

	80-GB*	60-GB*	40-GB*
<b>Dimensions</b>			
Height	9.5 mm	9.5 mm	9.5 mm
Width	70 mm	70 mm	70 mm
Weight	99 g	99 g	99 g
<b>Interface type</b>			
	ATA-5	ATA-5	ATA-5
<b>Transfer rate</b>			
Synchronous (maximum)	100 MB/sec	100 MB/sec	100 MB/sec
Security	ATA security	ATA security	ATA security
<b>Seek times</b> (typical read, including setting)			
Single track	3 ms	3 ms	3 ms
Average	13 ms	13 ms	13 ms
Maximum	24 ms	24 ms	24 ms
<b>Logical blocks</b> <sup>†</sup>			
	156,301,488	117,210,240	78,140,160
<b>Disc rotational speed</b>			
	4200 rpm	4200 rpm	4200 rpm
<b>Operating temperature</b>			
	5°C to 55°C (41°F to 131°F)		
 Certain restrictions and exclusions apply. Consult Customer Care for details.			

\*1 GB = 1 billion bytes when referring to hard drive storage capacity. Actual accessible capacity is less.

<sup>†</sup>Actual drive specifications may differ slightly.

**Table 6-4**  
**DVD/CD-RW Combo Drive**

<b>Applicable disc</b>	<b>Read:</b>	<b>Write:</b>
	DVD-R, DVD-RW, DVD-ROM (DVD-5, DVD-9, DVD-10, DVD-18), CD-ROM (Mode 1 and 2) CD Digital Audio, CD-XA ready (Mode 2, Form 1 and 2), CD-I ready (Mode 2, Form 1 and 2), CD-R, CD-RW, Photo CD (single and multisession), and CD-Bridge	CD-R and CD-RW
<b>Center hole diameter</b>	1.5 cm (0.59 in)	
<b>Disc diameter</b>		
Standard disc	12 cm (4.72 in)	
Mini disc	8 cm (3.15 in)	
<b>Disc thickness</b>	1.2 mm (0.047 in)	
<b>Track pitch</b>	0.74 $\mu$ m	



**Table 6-4**  
**DVD/CD-RW Combo Drive (Continued)**

<b>Access time</b>	CD media	DVD media
Random	< 110 ms	< 130 ms
Full stroke	< 210 ms	< 225 ms
<b>Audio output level</b>	Line-out, 0.7 V rms	
<b>Cache buffer</b>	2 MB	
<b>Data transfer rate</b>		
CD-R (24X)	3600 KB/s (150 KB/s at 1X CD rate)	
CD-RW (10X)	1500 KB/s (150 KB/s at 1X CD rate)	
CD-ROM (24X)	3600 KB/s (150 KB/s at 1X CD rate)	
DVD (8X)	10,800 KB/s (1352 KB/s at 1X DVD rate)	
Multiword DMA mode 2	16.6 MB/s	
<b>Startup time</b>	< 15 seconds	
<b>Stop time</b>	< 6 seconds	

**Table 6-5**

**DVD±RW and CD-RW Double-Layer Combo Drive**

<b>Applicable disc</b>	<b>Read:</b> DVD-R, DVD-RW, DVD-ROM (DVD-5, DVD-9, DVD-10, DVD-18), CD-ROM (Mode 1 and 2), CD Digital Audio, CD-XA ready (Mode 2, Form 1 and 2), CD-I ready (Mode 2, Form 1 and 2), CD-R, CD-RW, Photo CD (single and multisession), CD-Bridge	<b>Write:</b> CD-R and CD-RW DVD-R and DVD-RW
<b>Center hole diameter</b>	1.5 cm (0.59 in)	
<b>Disc diameter</b>		
Standard disc	12 cm (4.72 in)	
Mini disc	8 cm (3.15 in)	
<b>Disc thickness</b>	1.2 mm (0.047 in)	
<b>Track pitch</b>	0.74 μm	

Table 6-5

**DVD±RW and CD-RW Double-Layer Combo Drive (Continued)**

<b>Access time</b>	CD	DVD
Random	< 175 ms	< 230 ms
Full stroke	< 285 ms	< 335 ms
<b>Audio output level</b>	Audio-out, 0.7 Vrms	
<b>Cache buffer</b>	2 MB	
<b>Data transfer rate</b>		
CD-R (16X)	2,400 KB/s (150 KB/s at 1X CD rate)	
CD-RW (8X)	1,200 KB/s (150 KB/s at 1X CD rate)	
CD-ROM (24X)	3,600 KB/s (150 KB/s at 1X CD rate)	
DVD (8X)	10,800 KB/s (1,352 KB/s at 1X DVD rate)	
DVD-R (4X)	5,400 KB/s (1,352 KB/s at 1X DVD rate)	
DVD-RW (2X)	2,700 KB/s (1,352 KB/s at 1X DVD rate)	
Multword DMA mode 2	16.6 MB/s	
<b>Startup time</b>	< 15 seconds	
<b>Stop time</b>	< 6 seconds	

---

**Table 6-6**  
**System Interrupts**

<b>Hardware IRQ</b>	<b>System Function</b>
IRQ0	System timer
IRQ1	Standard 101-/102-Key or Microsoft Natural Keyboard
IRQ2	Cascaded
IRQ3	USB2 Enhanced Host Controller—24CD
IRQ4	COM1
IRQ5*	Conexant AC—Link Audio Data Fax Modem with SmartCP
IRQ6	Diskette drive
IRQ7*	Parallel port
IRQ8	System CMOS/real-time clock
IRQ9*	Microsoft ACPI-compliant system
IRQ10*	Realtek RTL8139 Family PCI fast Ethernet Controller

---

**Table 6-6**  
**System Interrupts (Continued)**

IRQ11	TI OHCI 1394 host controller TI PCI1410 CardBus controller
IRQ12	Synaptics PS/2 TouchPad
IRQ13	Numeric data processor
IRQ14	Primary IDE channel
IRQ15	Secondary IDE channel

\*Default configuration; audio possible configurations are IRQ5, IRQ7, IRQ9, IRQ10, or none.



PC Cards may assert IRQ3, IRQ4, IRQ5, IRQ7, IRQ9, IRQ10, IRQ11, or IRQ15. Either the infrared or the serial port may assert IRQ3 or IRQ4.

**Table 6-7**  
**System I/O Addresses**

<b>I/O Address (hex)</b>	<b>System Function (shipping configuration)</b>
000 - 00F	DMA controller no. 1
010 - 01F	Unused
020 - 021	Interrupt controller no. 1
022 - 024	Opti chipset configuration registers
025 - 03F	Unused
02E - 02F	87334 "Super I/O" configuration for CPU
040 - 05F	Counter/timer registers
044 - 05F	Unused
060	Keyboard controller
061	Port B
062 - 063	Unused
064	Keyboard controller
065 - 06F	Unused
070 - 071	NMI enable/RTC
072 - 07F	Unused
080 - 08F	DMA page registers
090 - 091	Unused
092	Port A
093 - 09F	Unused
0A0 - 0A1	Interrupt controller no. 2

**Table 6-7**  
**System I/O Addresses (*Continued*)**

<b>I/O Address (hex)</b>	<b>System Function (shipping configuration)</b>
0A2 - 0BF	Unused
0C0 - 0DF	DMA controller no. 2
0E0 - 0EF	Unused
0F0 - 0F1	Coprocessor busy clear/reset
0F2 - 0FF	Unused
100 - 16F	Unused
170 - 177	Secondary fixed disk controller
178 - 1EF	Unused
1F0 - 1F7	Primary fixed disk controller
1F8 - 200	Unused
201	Joystick (decoded in ESS1688)
202 - 21F	Unused
220 - 22F	Entertainment audio
230 - 26D	Unused
26E - 26	Unused
278 - 27F	Unused
280 - 2AB	Unused
2A0 - 2A7	Unused
2A8 - 2E7	Unused
2E8 - 2EF	Reserved serial port

**Table 6-7**  
**System I/O Addresses (Continued)**

<b>I/O Address (hex)</b>	<b>System Function (shipping configuration)</b>
2F0 - 2F7	Unused
2F8 - 2FF	Infrared port
300 - 31F	Unused
320 - 36F	Unused
370 - 377	Secondary diskette drive controller
378 - 37F	Parallel port (LPT1/default)
380 - 387	Unused
388 - 38B	FM synthesizer—OPL3
38C - 3AF	Unused
3B0 - 3BB	VGA
3BC - 3BF	Reserved (parallel port/no EPP support)
3C0 - 3DF	VGA
3E0 - 3E1	PC Card controller in CPU
3E2 - 3E3	Unused
3E8 - 3EF	Internal modem
3F0 - 3F7	“A” diskette controller
3F8 - 3FF	Serial port (COM1/default)
CF8 - CFB	PCI configuration index register (PCIDIVO-1)
CFC - CFF	PCI configuration data register (PCIDIVO-1)



**Table 6-8**  
**System Memory Map**

<b>Size</b>	<b>Memory Address</b>	<b>System Function</b>
640 KB	00000000-0009FFFF	Base memory
128 KB	000A0000-000BFFFF	Video memory
48 KB	000C0000-000CBFFF	Video BIOS
160 KB	000C8000-000E7FFF	Unused
64 KB	000E8000-000FFFFF	System BIOS
15 MB	00100000-00FFFFFF	Extended memory
58 MB	01000000-047FFFFFFF	Super extended memory
58 MB	04800000-07FFFFFFF	Unused
2 MB	08000000-080FFFFF	Video memory (direct access)
4 GB	08200000-FFFEFFFF	Unused
64 KB	FFFF0000-FFFFFFFF	System BIOS

---

**Table 6-9**  
**System DMA**

<b>Hardware DMA</b>	<b>System Function</b>
DMA0	Not applicable
DMA1*	Not applicable
DMA2*	Not applicable
DMA3	Not applicable
DMA4	Direct memory access controller
DMA5*	Available for PC Card
DMA6	Not assigned
DMA7	Not assigned

\*PC Card controller can use DMA 1, 2, or 5.

---

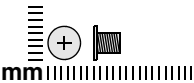
# A

## Screw Listing

This appendix provides specification and reference information for the screws and screw locks used in the computer. All screws listed in this appendix are available in the Computer Screw Kit, spare part number 407783-001, and the Display Screw Kit, spare part number 407795-001.

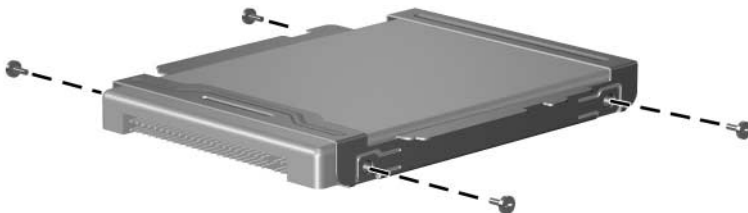
**Table A-1**

**Phillips PM3.0x4.0 Screw**

	Color	Qty.	Length	Thread	Head Width
	Black	4	4.0 mm	3.0 mm	5.0 mm

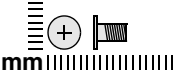
**Where used:**

4 screws that secure the hard drive frame to the hard drive (documented in [Section 5.4](#))



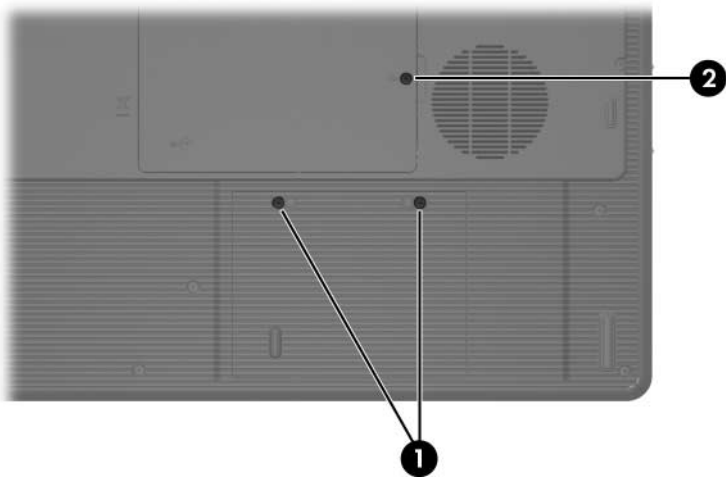
*Phillips PM3.0x4.0 Screw Locations*

**Table A-2**  
**Phillips PM2.5x5.0 Captive Screw**

 mm	Color	Qty.	Length	Thread	Head Width
	Black	3	5.0 mm	2.5 mm	5.0 mm

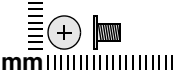
**Where used:**

- 1 Two screws that secure the hard drive cover to the computer (screws are captured on the cover by C clips; documented in [Section 5.4](#))
- 2 One screw that secures the memory/Mini PCI module compartment cover to the computer (screw is captured on the cover by C clips; documented in [Section 5.6](#))



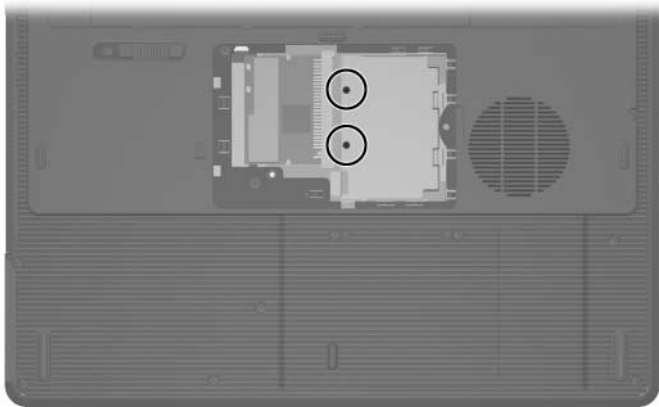
*Phillips PM2.5x5.0 Captive Screw Locations*

**Table A-3**  
**Black Phillips PM2.5×4.0 Screw**

 mm	Color	Qty.	Length	Thread	Head Width
	Black	2	4.0 mm	2.5 mm	5.0 mm

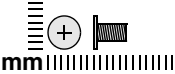
**Where used:**

Two screws that secure the memory shield to the computer (documented in [Section 5.6](#))



*Black Phillips PM2.5×4.0 Screw Locations*

**Table A-4**  
**Phillips PM2.5×5.0 Screw**

 mm	Color	Qty.	Length	Thread	Head Width
	Black	30	5.0 mm	2.5 mm	5.0 mm

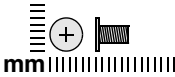
**Where used:**

One screw that secures the optical drive to the computer (documented in [Section 5.9](#))



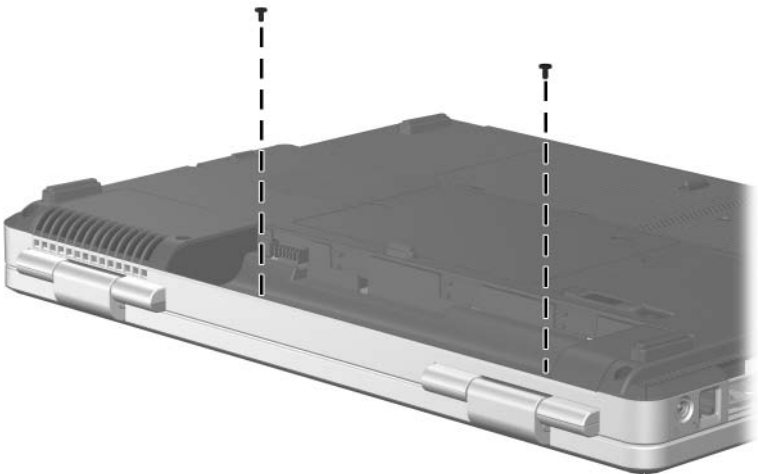
*Phillips PM2.5×5.0 Screw Location*

**Table A-4**  
**Phillips PM2.5x5.0 Screw (Continued)**

	Color	Qty.	Length	Thread	Head Width
	Black	30	5.0 mm	2.5 mm	5.0 mm

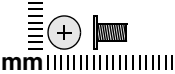
**Where used:**

2 screws that secure the switch cover to the computer (documented in [Section 5.10](#))



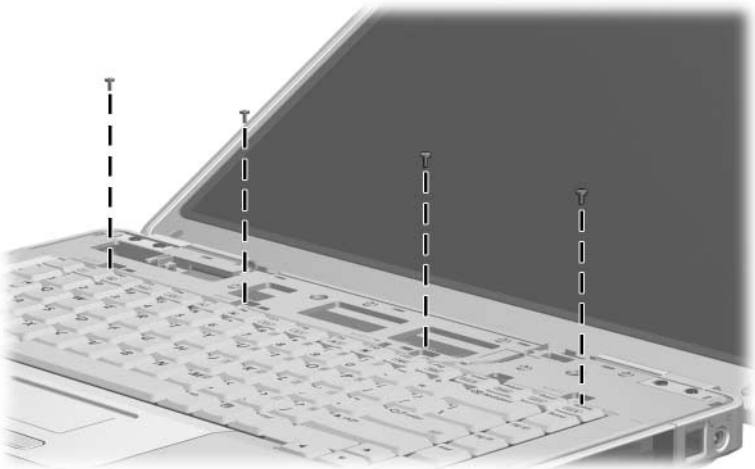
*Phillips PM2.5x5.0 Screw Locations*

**Table A-4**  
**Phillips PM2.5x5.0 Screw (Continued)**

	Color	Qty.	Length	Thread	Head Width
	Black	30	5.0 mm	2.5 mm	5.0 mm

**Where used:**

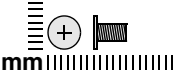
4 screws that secure the keyboard to the computer (documented in [Section 5.11](#))



*Phillips PM2.5x5.0 Screw Locations*

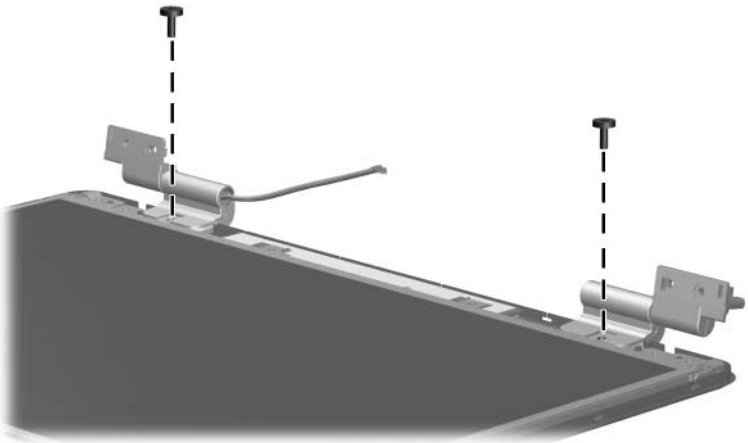


**Table A-4**  
**Phillips PM2.5x5.0 Screw (Continued)**

	Color	Qty.	Length	Thread	Head Width
	Black	30	5.0 mm	2.5 mm	5.0 mm

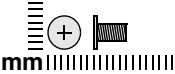
**Where used:**

2 screws that secure the display hinge base covers to the display enclosure (documented in [Section 5.12](#))



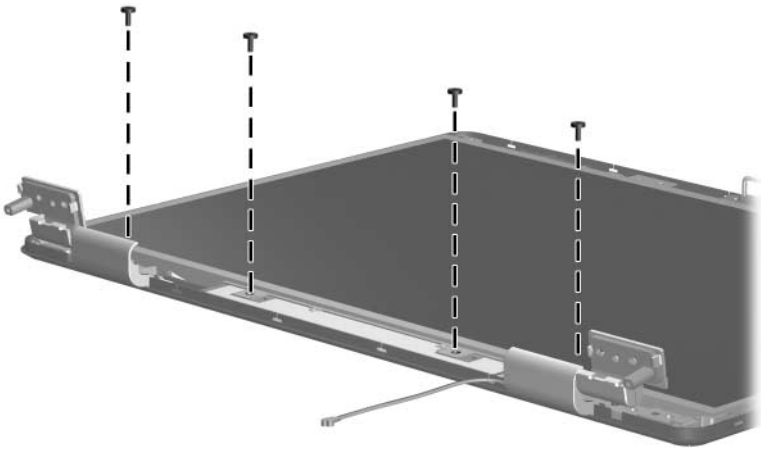
*Phillips PM2.5x5.0 Screw Locations*

**Table A-4**  
**Phillips PM2.5x5.0 Screw (Continued)**

	Color	Qty.	Length	Thread	Head Width
	Black	30	5.0 mm	2.5 mm	5.0 mm

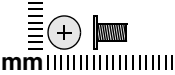
**Where used:**

4 screws that secure the display panel and inverter board to the display enclosure (documented in [Section 5.12](#))



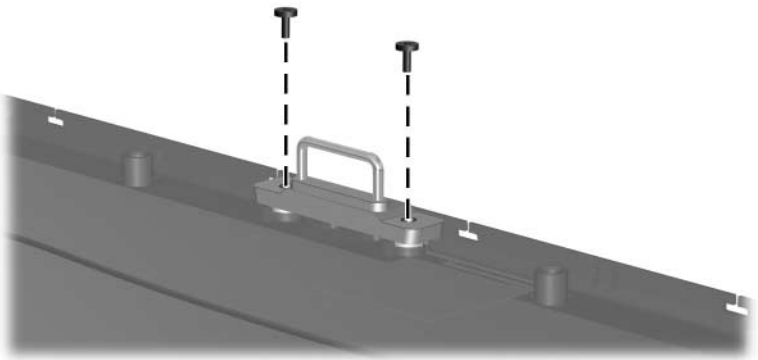
*Phillips PM2.5x5.0 Screw Locations*

**Table A-4**  
**Phillips PM2.5×5.0 Screw (Continued)**

	Color	Qty.	Length	Thread	Head Width
	Black	30	5.0 mm	2.5 mm	5.0 mm

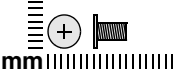
**Where used:**

2 screws that secure the display release hook to the display enclosure  
 (documented in [Section 5.12](#))



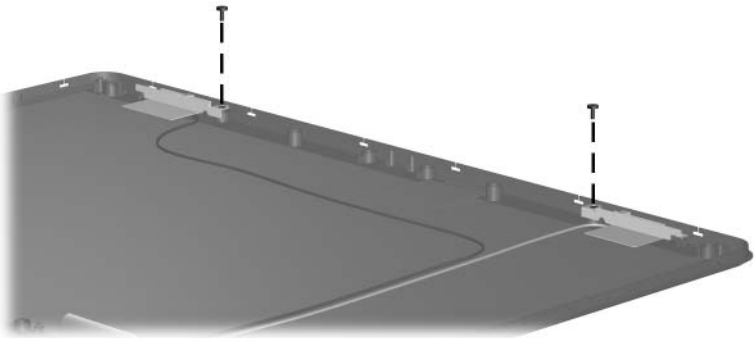
*Phillips PM2.5×5.0 Screw Locations*

**Table A-4**  
**Phillips PM2.5x5.0 Screw (Continued)**

	Color	Qty.	Length	Thread	Head Width
	Black	30	5.0 mm	2.5 mm	5.0 mm

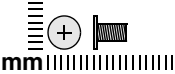
**Where used:**

2 screws that secure the wireless antenna transceivers to the display enclosure (documented in [Section 5.12](#))



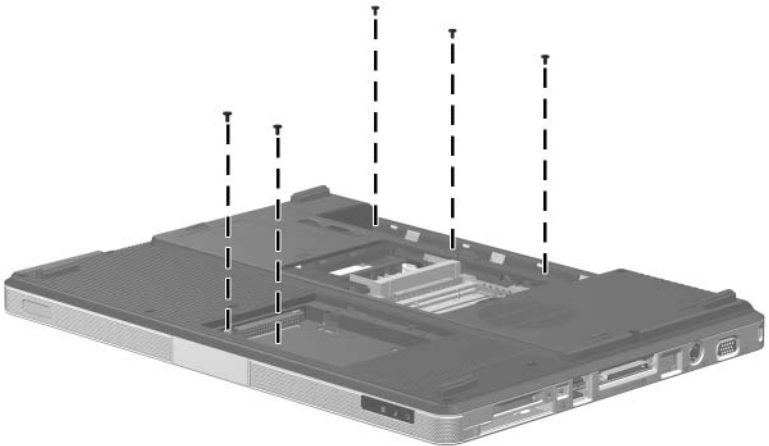
*Phillips PM2.5x5.0 Screw Locations*

**Table A-4**  
**Phillips PM2.5×5.0 Screw (Continued)**

	Color	Qty.	Length	Thread	Head Width
	Black	30	5.0 mm	2.5 mm	5.0 mm

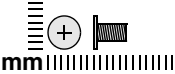
**Where used:**

5 screws that secure the base enclosure to the computer (documented in [Section 5.13](#))



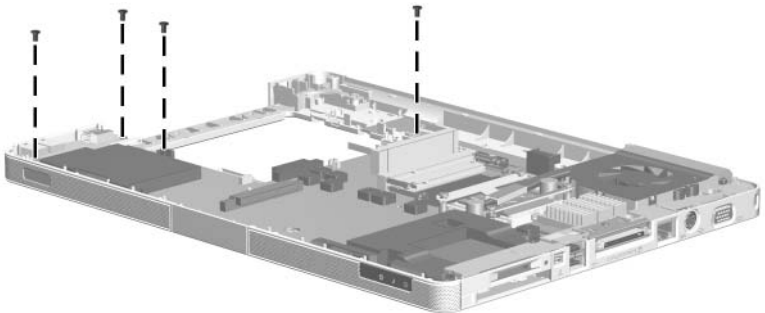
*Phillips PM2.5×5.0 Screw Locations*

**Table A-4**  
**Phillips PM2.5x5.0 Screw (Continued)**

	Color	Qty.	Length	Thread	Head Width
	Black	30	5.0 mm	2.5 mm	5.0 mm

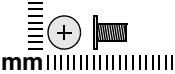
**Where used:**

4 screws that secure the system board to the top cover (documented in [Section 5.15](#))



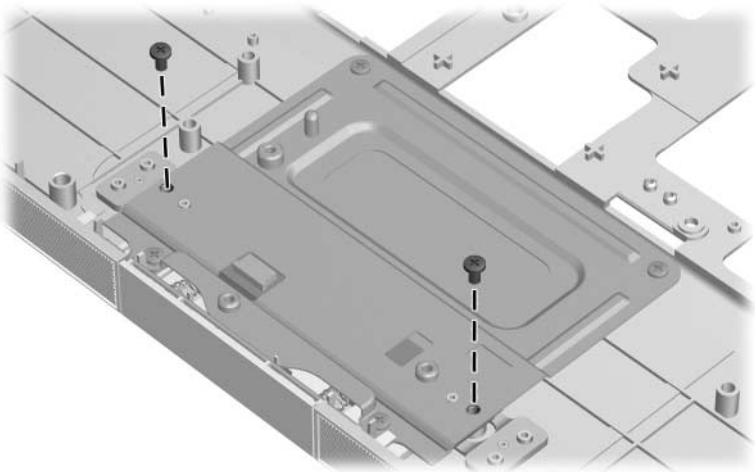
*Phillips PM2.5x5.0 Screw Locations*

**Table A-4**  
**Phillips PM2.5×5.0 Screw (Continued)**

	Color	Qty.	Length	Thread	Head Width
	Black	30	5.0 mm	2.5 mm	5.0 mm

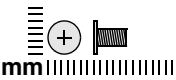
**Where used:**

2 screws that secure the TouchPad bracket to the top cover (documented in [Section 5.16](#))



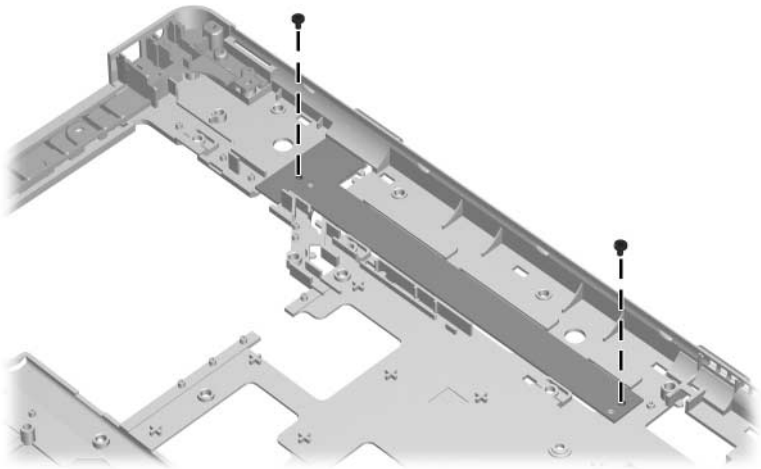
*Phillips PM2.5×5.0 Screw Locations*

**Table A-4**  
**Phillips PM2.5x5.0 Screw (Continued)**

	Color	Qty.	Length	Thread	Head Width
	Black	30	5.0 mm	2.5 mm	5.0 mm

**Where used:**

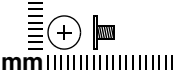
2 screws that secure the LED board to the top cover (documented in [Section 5.17](#))



*Phillips PM2.5x5.0 Screw Locations*

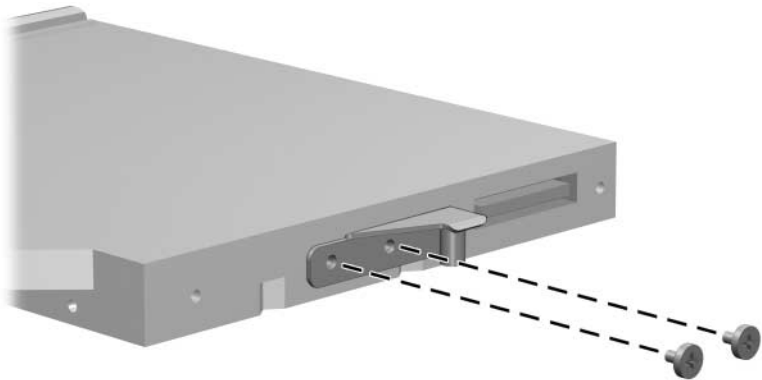


**Table A-5**  
**Phillips PM2.0×3.0 Screw**

	Color	Qty.	Length	Thread	Head Width
	Silver	2	3.0 mm	2.0 mm	5.0 mm

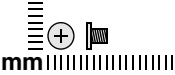
**Where used:**

2 screws that secure the optical drive bracket to the optical drive (documented in [Section 5.9](#))



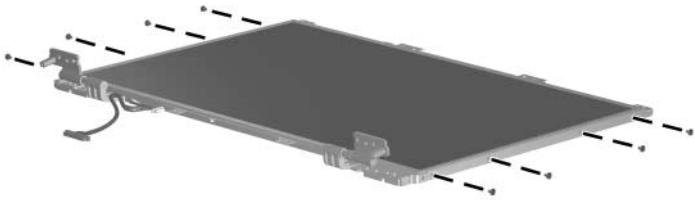
*Phillips PM2.0×3.0 Screw Locations*

**Table A-6**  
**Phillips PM2.0×4.0 Screw**

 mm	Color	Qty.	Length	Thread	Head Width
	Black	13	4.0 mm	2.0 mm	4.0 mm

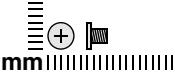
**Where used:**

8 screws that secure the display hinges to the display panel (documented in [Section 5.12](#))



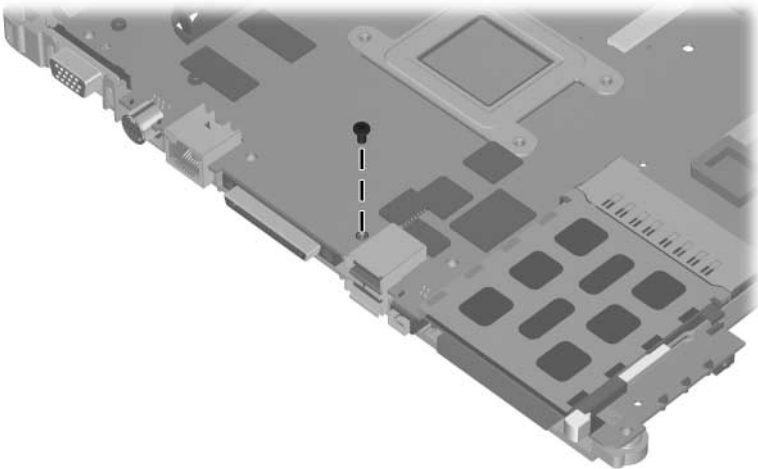
*Phillips PM2.0×4.0 Screw Locations*

**Table A-6**  
**Phillips PM2.0×4.0 Screw (Continued)**

	Color	Qty.	Length	Thread	Head Width
	Black	13	4.0 mm	2.0 mm	4.0 mm

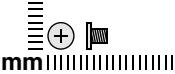
**Where used:**

One screw that secures the fan assembly to the system board (documented in [Section 5.20](#))



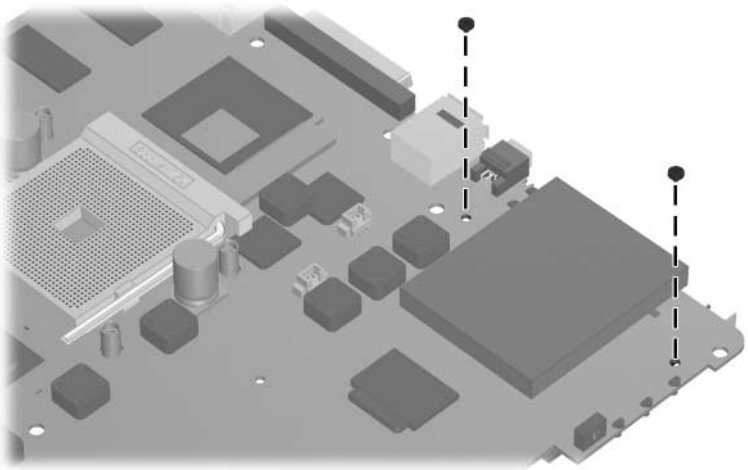
*Phillips PM2.0×4.0 Screw Location*

**Table A-6**  
**Phillips PM2.0x4.0 Screw (Continued)**

	Color	Qty.	Length	Thread	Head Width
	Black	13	4.0 mm	2.0 mm	4.0 mm

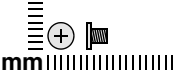
**Where used:**

Two screws that secure the PC Card assembly to the system board (documented in [Section 5.21](#))



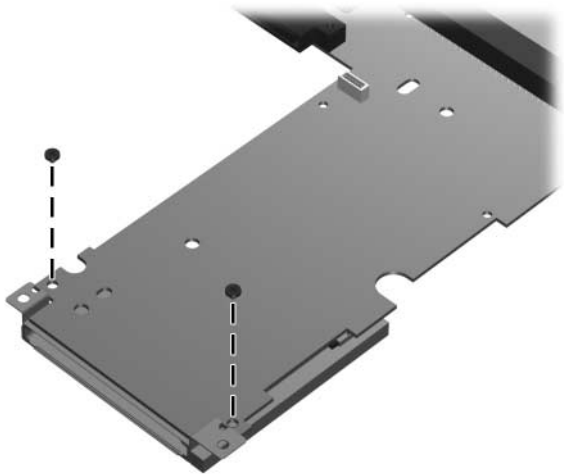
*Phillips PM2.0x4.0 Screw Locations*

**Table A-6**  
**Phillips PM2.0×4.0 Screw (Continued)**

	Color	Qty.	Length	Thread	Head Width
	Black	13	4.0 mm	2.0 mm	4.0 mm

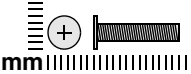
**Where used:**

Two screws that secure the ExpressCard assembly to the system board (documented in [Section 5.22](#))



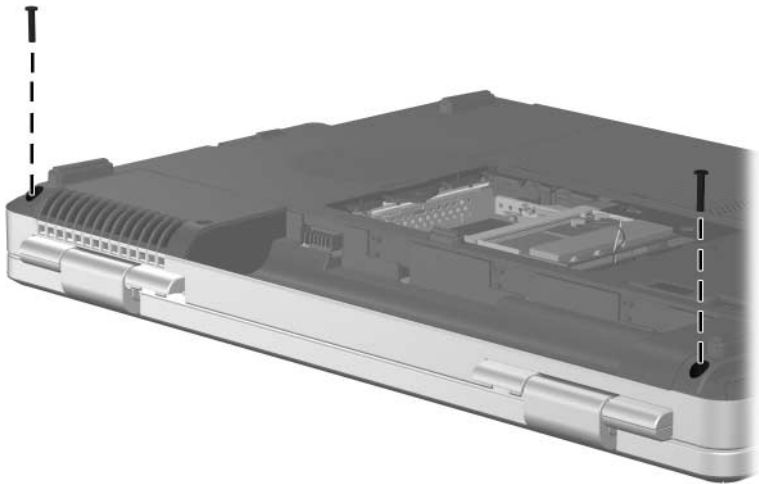
*Phillips PM2.0×4.0 Screw Locations*

**Table A-7**  
**Phillips PM2.5x13.0 Screw**

 mm	Color	Qty.	Length	Thread	Head Width
	Black	15	13.0 mm	2.5 mm	5.0 mm

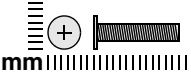
**Where used:**

2 screws that secure the display assembly to the computer (documented in [Section 5.12](#))



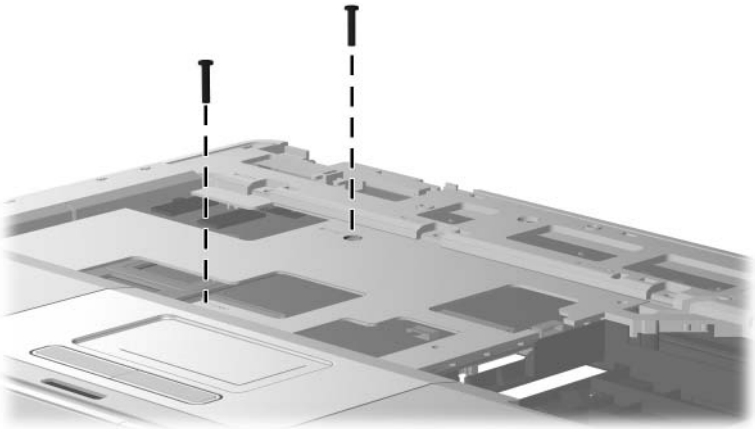
*Phillips PM2.5x13.0 Screw Locations*

**Table A-7**  
**Phillips PM2.5×13.0 Screw (Continued)**

	Color	Qty.	Length	Thread	Head Width
	Black	15	13.0 mm	2.5 mm	5.0 mm

**Where used:**

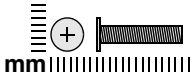
2 screws that secure the base enclosure to the computer (documented in [Section 5.13](#))



*Phillips PM2.5×13.0 Screw Locations*

**Table A-7**

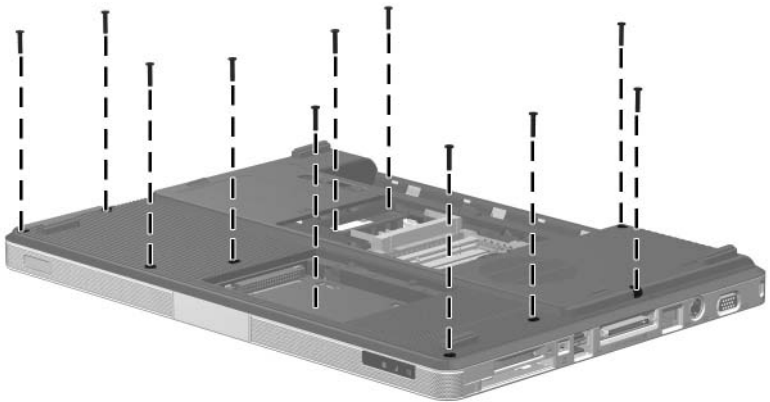
**Phillips PM2.5×13.0 Screw (Continued)**



	Color	Qty.	Length	Thread	Head Width
	Black	15	13.0 mm	2.5 mm	5.0 mm

**Where used:**

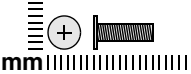
11 screws that secure the base enclosure to the computer (documented in [Section 5.13](#))



*Phillips PM2.5×13.0 Screw Locations*

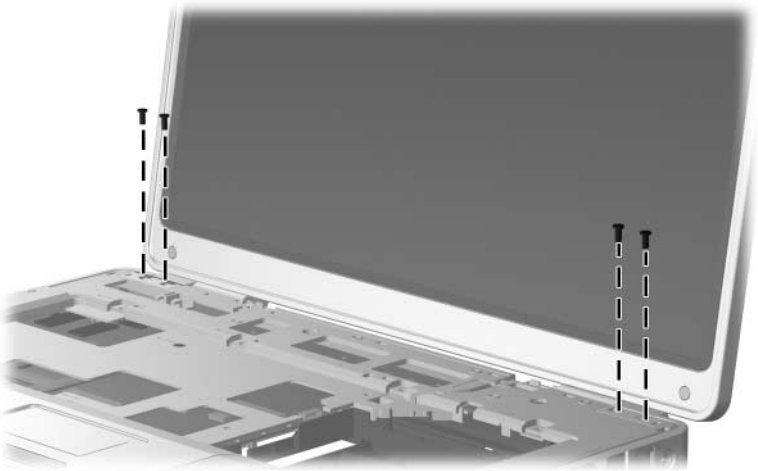


**Table A-8**  
**Phillips PM2.5×9.0 Screw**

 mm	Color	Qty.	Length	Thread	Head Width
	Black	4	9.0 mm	2.5 mm	5.0 mm

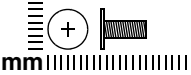
**Where used:**

4 screws that secure the display assembly to the computer (documented in [Section 5.12](#))



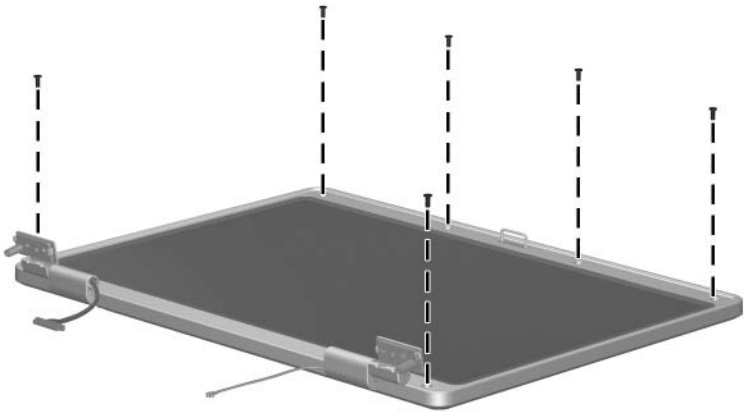
*Phillips PM2.5×9.0 Screw Locations*

**Table A-9**  
**Phillips PM2.5×7.0 Screw**

	Color	Qty.	Length	Thread	Head Width
mm	Silver	10	7.0 mm	2.5 mm	6.0 mm

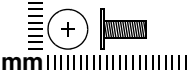
**Where used:**

6 screws that secure the display bezel to the display enclosure (documented in [Section 5.12](#))



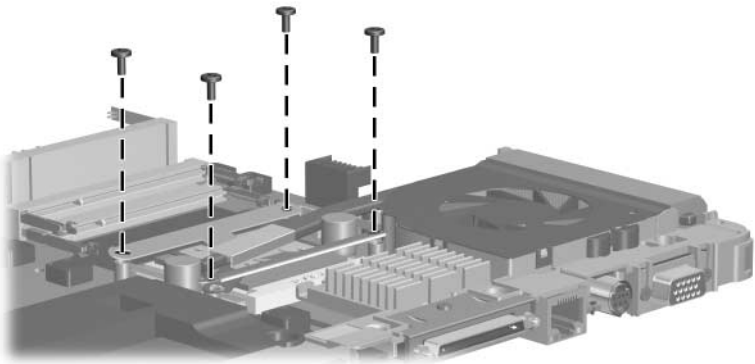
*Phillips PM2.5×7.0 Screw Locations*

**Table A-9**  
**Phillips PM2.5x7.0 Screw (Continued)**

	Color	Qty.	Length	Thread	Head Width
	Silver	10	7.0 mm	2.5 mm	6.0 mm



**Where used:**

4 screws that secure the heat sink to the system board (documented in [Section 5.18](#))



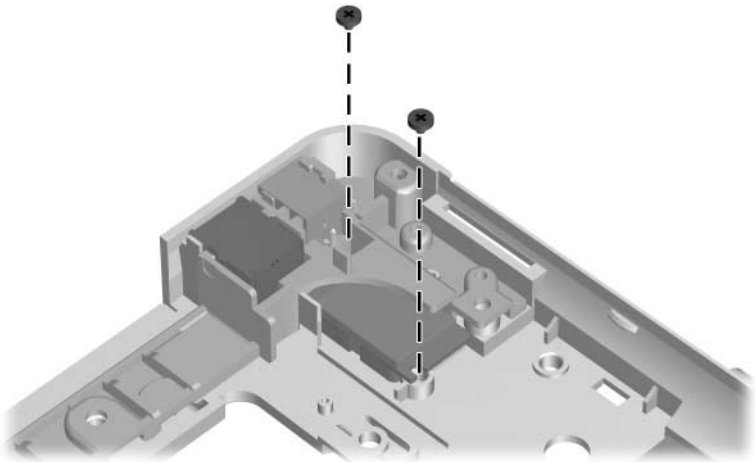
*Phillips PM2.5x7.0 Screw Locations*

**Table A-10**  
**Phillips PM1.5x3.0 Screw**

 mm 	Color	Qty.	Length	Thread	Head Width
	Silver	2	3.0 mm	1.5 mm	3.0 mm

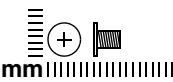
**Where used:**

2 screws that secure the Bluetooth module to the top cover (documented in [Section 5.14](#))



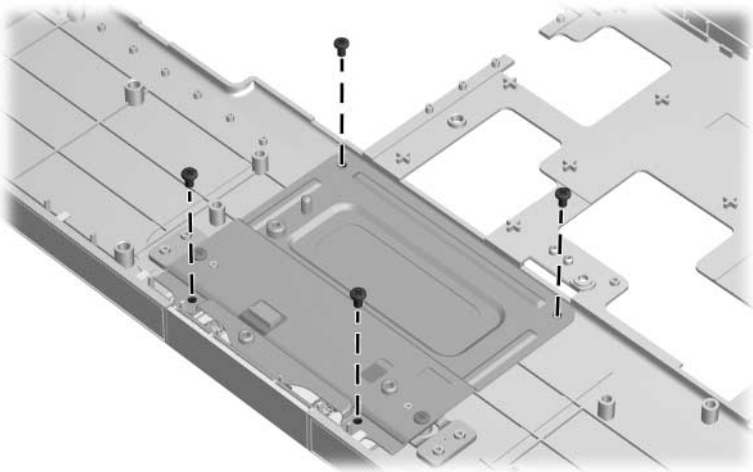
*Phillips PM1.5x3.0 Screw Locations*

**Table A-11**  
**Silver Phillips PM2.5×4.0 Screw**

	Color	Qty.	Length	Thread	Head Width
	Silver	5	4.0 mm	2.5 mm	5.0 mm

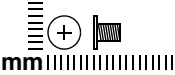
**Where used:**

4 screws that secure the display bezel to the display enclosure (documented in [Section 5.16](#))



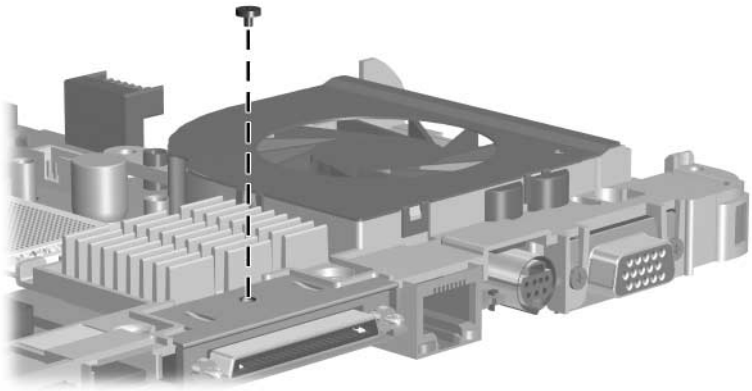
*Silver Phillips PM2.5×4.0 Screw Locations*

**Table A-11**  
**Silver Phillips PM2.5×4.0 Screw (Continued)**

 mm	Color	Qty.	Length	Thread	Head Width
	Silver	5	4.0 mm	2.5 mm	5.0 mm

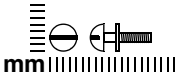
**Where used:**

One screw that secures the expansion port 2 bracket and fan assembly to the system board (documented in [Section 5.20](#))



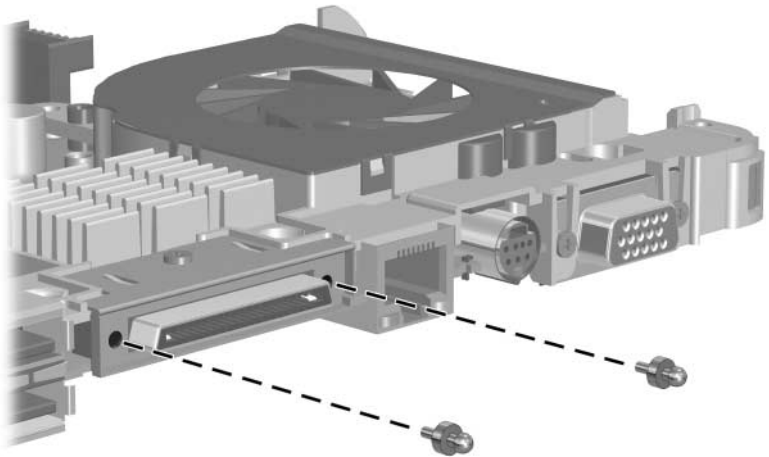
*Silver Phillips PM2.5×4.0 Screw Location*

**Table A-12**  
**Slotted SM1.5x9.0 Screw**

	Color	Qty.	Length	Thread	Head Width
	Silver	2	9.0 mm	1.5 mm	4.0 mm

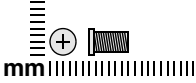
**Where used:**

2 screws that secure the fan assembly to the system board (documented in [Section 5.20](#))



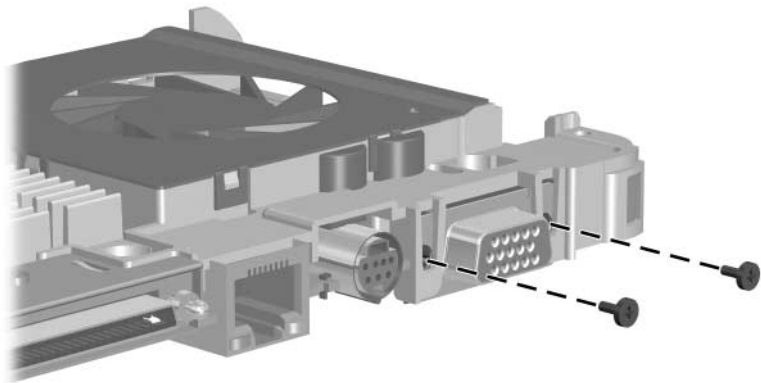
*Slotted M1.5x9.0 Screw Locations*

**Table A-13**  
**Phillips PM3.0x6.0 Screw**

	Color	Qty.	Length	Thread	Head Width
	Black	2	6.0 mm	3.0 mm	4.0 mm

**Where used:**

2 screws that secure the fan assembly to the system board (documented in [Section 5.20](#))



*Phillips PM3.0x6.0 Screw Locations*



---

## Software Update and Recovery

### Updating Software

Updated versions of the software provided with your computer may be available on the HP Web site.

Most software and BIOS updates on the HP Web site are packaged in compressed files called *SoftPaqs*.

Some download packages contain a file named *Readme.txt*, which contains information regarding installing and troubleshooting the file.

To update the software:

1. Identify your computer model, product category, and series or family. Prepare for a system BIOS update by identifying the BIOS version currently installed on the computer.

If your computer is connected to a network, consult the network administrator before installing any software updates, especially system BIOS updates.



The computer system BIOS is stored on the system ROM. The BIOS initializes the operating system, determines how the computer will interact with the hardware devices, and provides for data transfer among hardware devices, including the time and date.

---

2. Access the updates by visiting the HP Web site at <http://www.hp.com>.
3. Install the updates.

## Updating the BIOS

To determine whether available BIOS updates contain later BIOS versions than those currently installed on the computer, you need to know the version of the system BIOS currently installed.

BIOS version information (also known as *ROM date* and *System BIOS*) can be displayed by pressing **fn+esc** (if you are already in Microsoft® Windows®) or by opening the Setup Utility.

To use the Setup Utility for displaying BIOS information:

1. Open the Setup Utility by turning on or restarting the computer, and then pressing **f10** while the “Press <F10> to enter Setup” message is displayed in the lower-left corner of the screen.
2. If the Setup Utility does not open with the system information displayed, use the arrow keys to select the **Main** menu.

When the Main menu is selected, BIOS and other system information is displayed.

3. To exit the Setup Utility, use the arrow keys to select **Exit > Exit Discarding Changes**, and then press **enter**.



**CAUTION:** To prevent damage to the computer or an unsuccessful installation, download and install a BIOS update only when the computer is connected to reliable external power using the AC adapter. Do not download or install a BIOS update while the computer is running on battery power, docked in an optional docking device, or connected to an optional power source. During the download and installation, follow these instructions:

- Do not disconnect power from the computer by unplugging the power cord from the AC outlet.
  - Do not shut down the computer or initiate standby or hibernation.
  - Do not insert, remove, connect, or disconnect any device, cable, or cord.
-

To download a BIOS update:

1. Access the page on the HP Web site that provides software for your computer:  
Select **Start > Help and Support**, and then select the software and drivers update.
2. Follow the instructions on the screen to identify your computer and access the BIOS update you want to download.
3. At the download area:
  - a. Identify the BIOS update that is later than the BIOS version currently installed on your computer. Make a note of the date, name, or other identifier. You may need this information to locate the update later, after it has been downloaded to your hard drive.
  - b. Follow the instructions on the screen to download your selection to the hard drive.

Make a note of the path to the location on your hard drive where the BIOS update will be downloaded. You will need to access this path when you are ready to install the update.



If you connect your computer to a network, consult the network administrator before installing any software updates, especially system BIOS updates.

---

BIOS installation procedures vary. Follow any instructions that are displayed on the screen after the download is complete. If no instructions are displayed, follow these steps:

1. Open Windows Explorer by selecting **Start > All Programs > Accessories > Windows Explorer**.
2. In the left pane of the Windows Explorer window:
  - a. Click **My Computer** and then your hard drive designation. The hard drive designation is typically Local Disk (C:).
  - b. Using the hard drive path you recorded earlier, open the folder on your hard drive that contains the update.

3. Double-click the file that has an .exe extension (for example, *filename.exe*).

The BIOS installation begins.

4. Complete the installation by following the instructions on the screen.



After a message on the screen reports a successful installation, you can delete the downloaded file from your hard drive.

---

## Updating Software Programs and Drivers

To download and install software other than a BIOS update:

1. Access the page on the HP Web site that provides software for your computer:

Select **Start > Help and Support**, and then select the software and drivers update.

2. Follow the instructions on the screen to find the software you want to update.
3. At the download area, select the software you want to download and follow the instructions on the screen.



Make a note of the path to the location on your hard drive where the software will be downloaded. You will need to access this path when you are ready to install the software.

---

4. When the download is complete, open Windows Explorer by selecting **Start > All Programs > Accessories > Windows Explorer**.
5. In the left pane of the Windows Explorer window:
  - a. Click **My Computer** and then your hard drive designation. The hard drive designation is typically Local Disk (C:).
  - b. Using the hard drive path you recorded earlier, open the folder on your hard drive that contains the update.

6. Double-click the file that has an .exe extension (for example, *filename.exe*).

The installation begins.

7. Complete the installation by following the instructions on the screen.



After a message on the screen reports a successful installation, you can delete the download package from your hard drive.

---

## Recovering System Information

Tools provided by the operating system and PC Recovery software are designed to help you with the following tasks for safeguarding your information and restoring it in case of a system failure:

- Back up your information regularly to protect your important system files.
- Make a set of recovery discs (PC Recovery software feature). Recovery discs are used to start up (boot) your computer and restore the operating system and software programs to factory settings in case of system failure or instability.
- Create system restore points (operating system feature). System restore points allow you to reverse undesirable changes to your computer by restoring the computer to an earlier state.
- Recover a program or driver (PC Recovery software feature). This feature helps you reinstall a program or driver without performing a full system recovery.
- Perform a full system recovery (PC Recovery software feature). With PC Recovery, you can recover your full factory image if you experience system failure or instability. PC Recovery works from a dedicated recovery partition on the hard drive or from recovery discs you create.

## Backing Up Your Information

### When to Back Up

- On a regularly scheduled basis.



Set reminders to back up your information periodically.

---

- Before the computer is repaired or restored.
- Before you add or modify hardware or software.

### Backup Suggestions

- Create system restore points using Windows XP Professional System Restore feature.
- Store personal files in the My Documents folder and back up these folders periodically.
- Back up templates stored in their associated programs.
- Save customized settings in a window, toolbar, or menu bar by taking a screen shot of your settings.

The screen shot can be a time saver if you have to reset your preferences.

To copy the screen and paste it into a Word document:

- a. Display the screen.
- b. Copy the screen:

To copy only the active window, press **alt+fn+prt sc**.

To copy the entire screen, press **fn+prt sc**.

- c. To paste the copied images into a document, open Word, and then select **Edit > Paste**.

## Using System Restore Points

When you back up your system, you are creating a system restore point. A system restore point allows you to save and name a snapshot of your hard drive at a specific point in time. You can then recover back to that point if you want to reverse subsequent changes made to your system.



---

Recovering to an earlier restore point does not affect data files saved or e-mails created since the last restore point.

---

You also can create additional restore points to provide increased protection for your system files and settings.

### When to Create Restore Points

- Before you add or extensively modify software or hardware.
- Periodically, whenever the system is performing optimally.



---

If you revert to a restore point and then change your mind, you can reverse the restoration.

---

### Create a System Restore Point

1. Select **Start > Help and Support**, and then click **System Restore**.  
The System Restore window opens.
2. Click **Create a restore point**, and then click **Next**.
3. Follow the on-screen instructions.

## Restore to a Previous Date and Time

To revert to a restore point (created at a previous date and time), when the computer was functioning optimally:

1. Select **Start > Help and Support**, and then click **System Restore**.

The System Restore window opens.

2. Click **Restore my computer to an earlier time**, and then click **Next**.
3. Follow the on-screen instructions.

## Creating Recovery Discs

PC Recovery Disc Creator creates a set of recovery CDs or DVDs for the computer. Use recovery discs to restore the operating system and software programs to factory settings, in case of system failure or instability.



Handle these discs carefully and keep them in a safe place. The software allows the creation of only one set of recovery discs.

---

Note the following guidelines before creating recovery discs:

- You will need high quality CD-R, DVD-R, or DVD+R media (purchased separately).
- 



DVD±RW/R and double-layer DVD±RW are not compatible with the PC Recovery Disc Creator software.

---

- The computer must be connected to AC power during this process.
- Only one set of recovery discs can be created per computer.



- Number each disc before inserting it into the computer optical drive.
- If necessary, you can exit the program before you have finished creating the recovery discs. The next time you open PC Recovery Disc Creator, you will be prompted to continue the disc creation process.

To create a set of recovery discs:

1. Select **Start > All Programs > System Recovery > PC Recovery Disc Creator**.

The PC Recovery Disc Creator tool opens.

2. Click **Next**.



If you are operating the computer on battery power, you will be prompted to connect to AC power before you can go to the next step.

---

3. Select the type of disc you want to use and click **Next**.



The software examines the image and displays the number of blank discs needed to create your recovery discs.

---

4. Insert the first disc and follow the on-screen instructions to complete the creation of the recovery discs.

## Reinstalling Software Programs and Drivers

If a program or driver preinstalled at the factory is accidentally erased or is damaged, the Application and Driver Recovery tool allows you to reinstall it.

---



Software not provided with this computer must be reinstalled from the disc provided by the manufacturer or downloaded from the manufacturer's Web site.

---



Before reinstalling the program, be sure it is fully uninstalled.

---

The Application and Driver Recovery tool replaces corrupted system files and reinstalls deleted system files within the program.

- In most cases, if the program you are reinstalling is still on your computer, the reinstallation process does not affect your personal settings.
- In all cases, if a program has been deleted from your computer, the reinstallation process reinstalls the program or utility to the factory image but cannot restore your personal settings.

## Reinstalling Preinstalled Programs and Drivers

1. Remove the program or driver:
- 



In some cases, drivers are not listed in the Add or Remove Programs list. If the driver is not listed, it does not need to be removed.

---

- a. Select **Start > Control Panel > Add or Remove Programs**.
- b. Click the program or driver you want to remove, and then click **Change/Remove**.

2. Select **Start > All Programs > System Recovery > Application and Driver Recovery**.

The Application and Driver Recovery tool opens.

3. Select **Application Installation or Driver Installation**, and then click **Next**.
4. Follow the on-screen instructions to complete the program or driver recovery.
5. Restart the computer if prompted.

## Reinstalling Programs from Discs

1. Insert the disc into the optical drive.
2. When the installation wizard opens, follow the installation instructions on the screen.
3. Restart the computer if prompted.

## Performing a Recovery

PC Recovery software allows you to repair or restore the system if you experience system failure or instability. PC Recovery works from recovery discs that you create or from a dedicated recovery partition on the hard drive.

---



Microsoft Windows XP has its own built-in repair features, such as System Restore and driver roll-back capabilities. If you have not already tried these features, try them before using PC Recovery.

---



PC Recovery only recovers software that was preinstalled at the factory. Software not provided with this computer must be reinstalled from the disc provided by the manufacturer or downloaded from the manufacturer's Web site.

---

## Recovering from the Recovery Discs

To restore the system from the recovery discs:

1. Back up all personal files.
2. Insert the first recovery disc into the optical drive and restart the computer.
3. Follow the on-screen instructions.

## Recovering from the Partition on the Hard Drive

You can perform a recovery from the partition on the hard drive from either the Start button or **f11**.

To restore the system from the partition:

1. Access the PC Recovery tool:
  - ❑ To access PC Recovery from the Start button, select **Start > All Programs > System Recovery > PC Recovery**.
  - ❑ To access PC Recovery from **f11**, restart the computer and press **f11** while the “Press <F11> for recovery” message is displayed on the screen.

The PC Recovery tool opens.

2. Select **PC Recovery** and click **Next**.

The computer restarts and the PC Recovery tool opens.

3. Click **OK**.
4. Follow the on-screen instructions to complete the system recovery.

If you want to perform a *destructive* recovery:



A destructive recovery formats the hard drive and restores the computer to its factory state. Select this option only as a last resort.

---

- a. Click **Advanced Options** on the System Recovery screen.
- b. Select **Destructive Recovery** and follow the on-screen instructions.

## Deleting the Recovery Partition on the Hard Drive

The PC Recovery Advanced Options menu provides the option of deleting the recovery partition, which will increase space on the hard drive. Delete the recovery partition only if you have already created recovery discs.



---

**CAUTION:** After you create the recovery discs, you can increase space on the hard drive by deleting the recovery partition. However, doing this is not recommended. If you delete this partition, you will lose any information that is on the partition, including the PC Recovery software. Thereafter, you must use the recovery discs to access PC Recovery software.

---

To delete the recovery partition:

1. If you have not already created recovery discs, create them now.
2. Select **Start > All Programs > System Recovery > PC Recovery**.  
The PC Recovery tool opens.
3. Select **PC Recovery** and click **Next**.  
The computer restarts and the PC Recovery tools opens.
4. Click **OK**.
5. At the System Recovery screen, click **Advanced Options**.
6. Select **Delete Recovery Partition (not recommended)** and follow the on-screen instructions.

## **Updating Reinstalled Software**

After you perform a system recovery, connect to the Internet to update all reinstalled software.

To access update links for the operating system and other software provided on your computer:

» Select **Start > Help and Support**.

To update optional software, follow the instructions provided by the software manufacturer. Some programs include an update feature you can access from a Help button or menu within the program.

---

# Display Component Recycling

---



**WARNING:** The backlight contains mercury. Caution should be exercised when removing and handling the backlight to avoid damaging this component and causing exposure to the mercury.

---



**CAUTION:** The procedures in this appendix can result in damage to display components. The only components intended for recycling purposes are the liquid crystal display (LCD) panel and the backlight. Careful handling should be exercised when removing these components.

---



## Materials Disposal

This HP product contains mercury in the display assembly backlight and may require special handling at end-of-life.

Disposal of mercury may be regulated because of environmental considerations. For disposal or recycling information, contact your local authorities or visit the Electronic Industries Alliance (EIA) at <http://www.eiae.org>.

---

This appendix provides disassembly instructions for the display assembly. The display assembly must be disassembled to gain access to the backlight ❶ and the LCD panel ❷.



Disassembly procedures differ from one display assembly to another. The procedures provided in this appendix are general disassembly instructions. Specific details, such as screw sizes, quantities, and locations, and component shapes and sizes, can vary from one computer model to another.

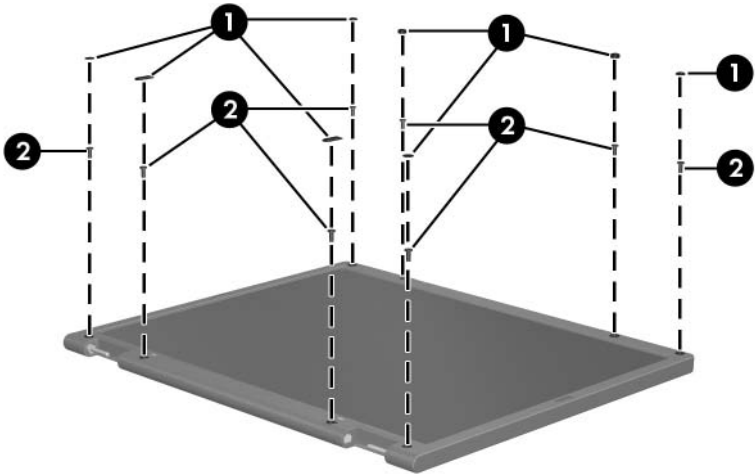
Refer to [Section 5.12, “Display Assembly,”](#) for display assembly disassembly steps.

---



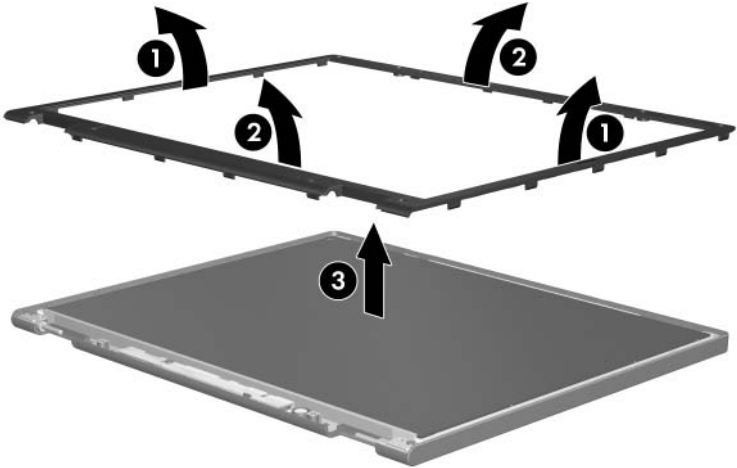
Perform the following steps to disassemble the display assembly:

1. Remove all screw covers **1** and screws **2** that secure the display bezel to the display assembly.



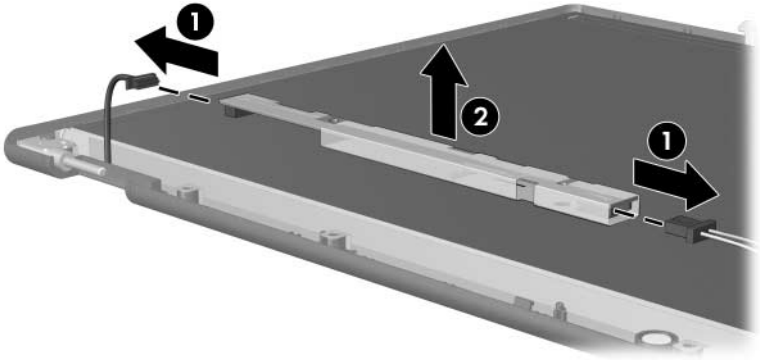
*Removing the Display Bezel Screw Covers and Screws*

- 
2. Lift up and out on the left and right inside edges ① and the top and bottom inside edges ② of the display bezel until the bezel disengages from the display assembly.
3. Remove the display bezel ③.



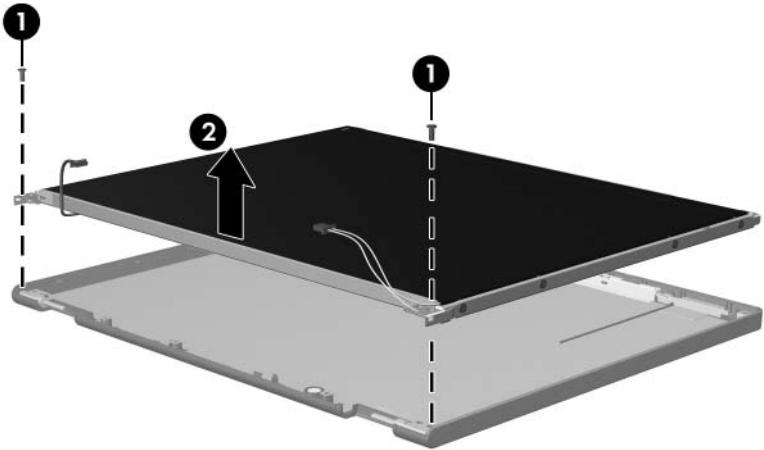
*Removing the Display Bezel*

4. Disconnect all LCD panel cables ❶ from the display inverter board and remove the inverter board ❷.



*Removing the Display Inverter Board*

5. Remove all screws ❶ that secure the LCD panel to the display enclosure.
6. Remove the LCD panel ❷ from the display enclosure.



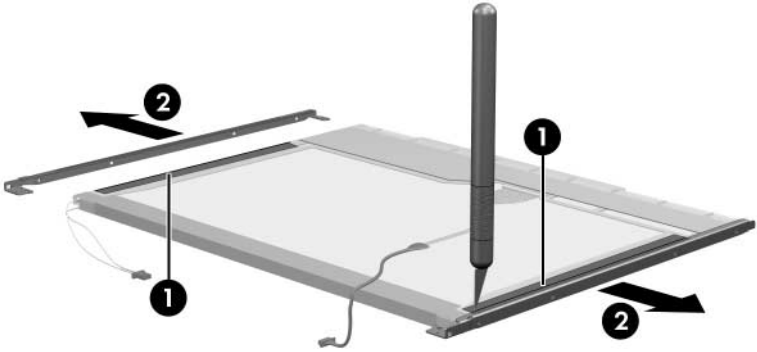
*Removing the LCD Panel*

7. Turn the LCD panel upside down.
8. Remove all screws that secure the LCD panel frame to the LCD panel.



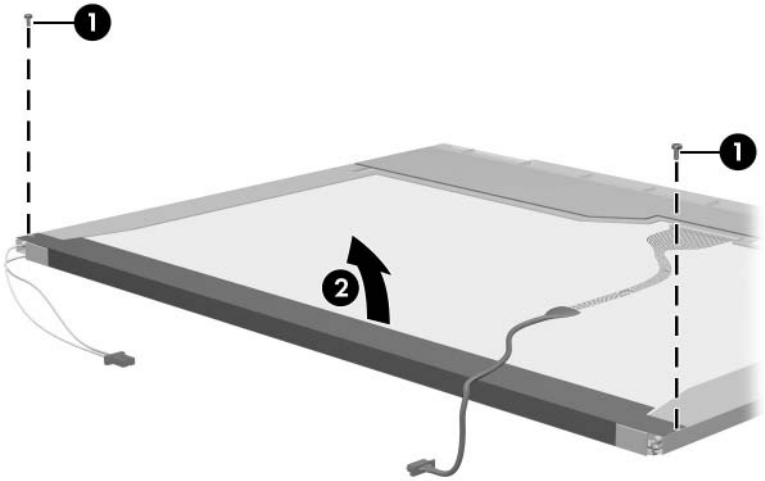
*Removing the LCD Panel Frame Screws*

9. Use a sharp-edged tool to cut the tape ❶ that secures the side of the LCD panel to the LCD panel frame.
10. Remove the LCD panel frame ❷ from the display panel.



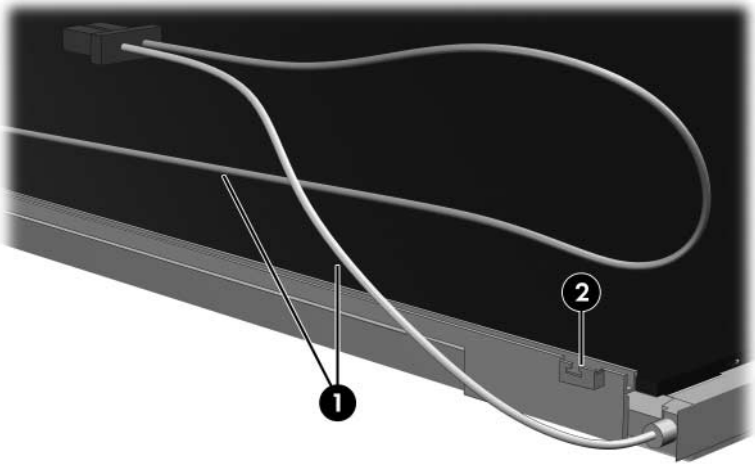
*Removing the LCD Panel Frame*

11. Remove the screws ❶ that secure the backlight cover to the LCD panel.
12. Lift the top edge of the backlight cover ❷ and swing it forward.
13. Remove the backlight cover.



*Removing the Backlight Cover*

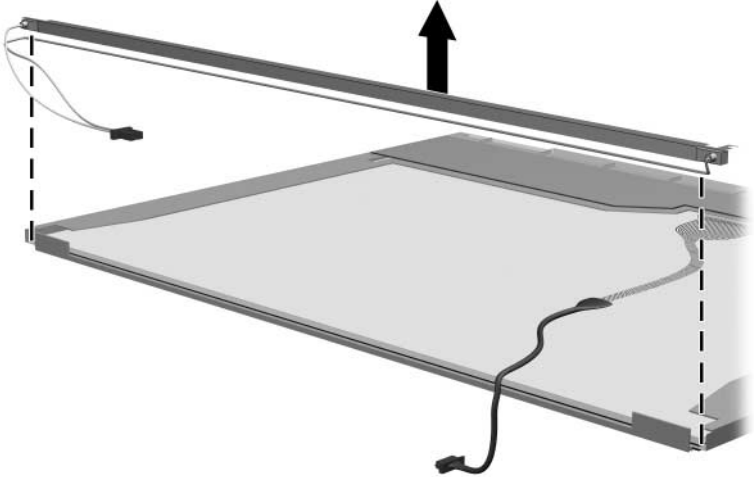
14. Turn the LCD panel right-side up.
15. Remove the backlight cables **1** from the clip **2** in the LCD panel.



*Releasing the Backlight Cables*



16. Turn the LCD panel upside down.
17. Remove the backlight frame from the LCD panel.



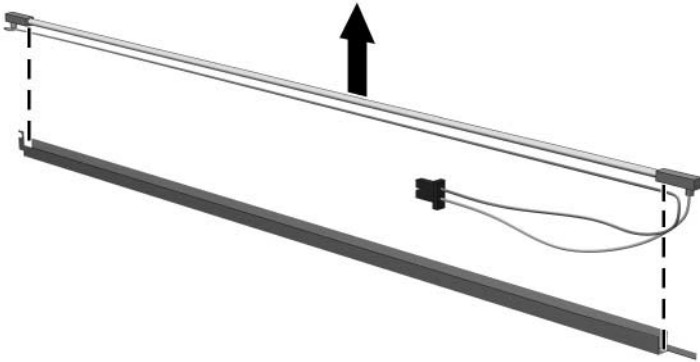
*Removing the Backlight Frame*



**WARNING:** The backlight contains mercury. Caution should be exercised when removing and handling the backlight to avoid damaging this component and causing exposure to the mercury.

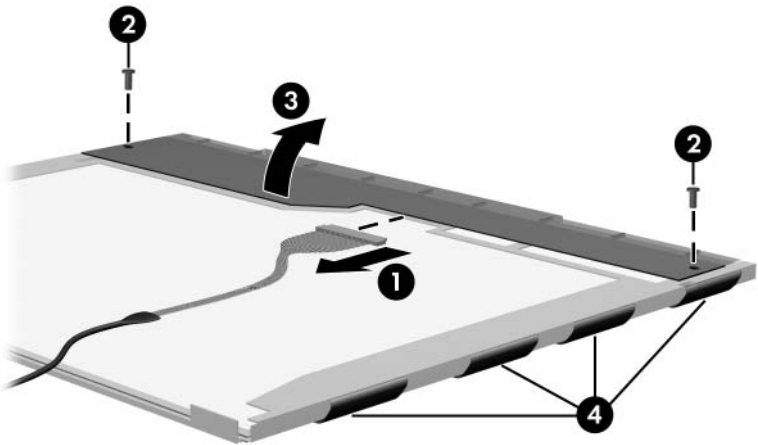
---

18. Slide the backlight out of the backlight frame.



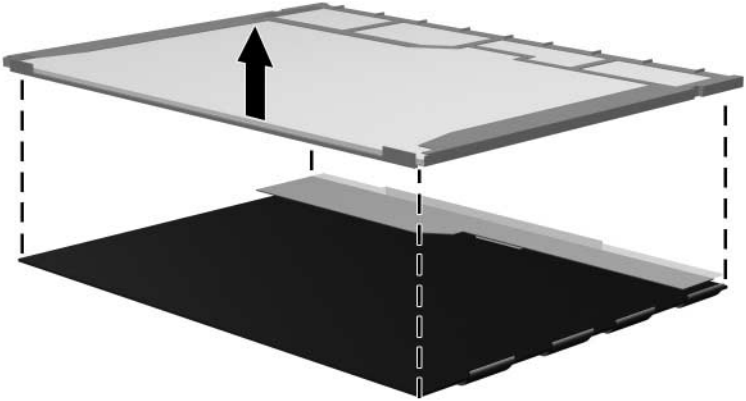
*Removing the Backlight*

19. Disconnect the display cable ❶ from the LCD panel.
20. Remove the screws ❷ that secure the LCD panel to the LCD rear panel.
21. Release the LCD panel ❸ from the LCD rear panel.
22. Release the tape ❹ that secures the LCD panel to the LCD rear panel.



*Releasing the LCD Panel*

23. Remove the LCD panel.



*Removing the LCD Panel*

24. Recycle the backlight and LCD panel.

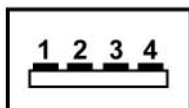
# D

---

## Connector Pin Assignments

---

**Table D-1**  
**Universal Serial Bus**



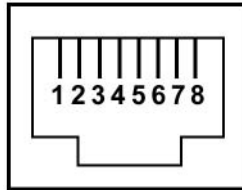
---

<b>Pin</b>	<b>Signal</b>	<b>Pin</b>	<b>Signal</b>
1	+5 VDC	3	Data +
2	Data -	4	Ground

---

---

**Table D-2**  
**RJ-45 (Network)**



---

<b>Pin</b>	<b>Signal</b>	<b>Pin</b>	<b>Signal</b>
1	Transmit +	5	Unused
2	Transmit –	6	Receive –
3	Receive +	7	Unused
4	Unused	8	Unused

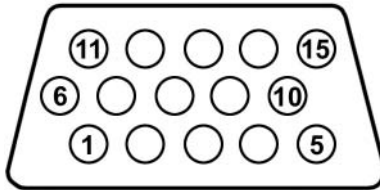
---

**Table D-3**  
**S-Video-Out**



<b>Pin</b>	<b>Signal</b>	<b>Pin</b>	<b>Signal</b>
1	TV-Ground	5	TV-CD
2	TV-CVBS	6	TV-Ground
3	TV-Ground	7	TV-YD
4	TV-Ground		

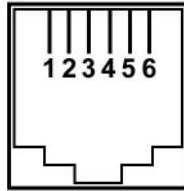
**Table D-4**  
**External Monitor**



<b>Pin</b>	<b>Signal</b>	<b>Pin</b>	<b>Signal</b>
1	Red analog	9	+5 VDC
2	Green analog	10	Ground
3	Blue analog	11	Monitor detect
4	Not connected	12	DDC 2B data
5	Ground	13	Horizontal sync
6	Ground analog	14	Vertical sync
7	Ground analog	15	DDC 2B clock
8	Ground analog		

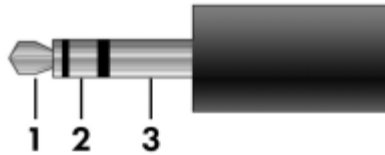


**Table D-5**  
**RJ-11 (Modem)**



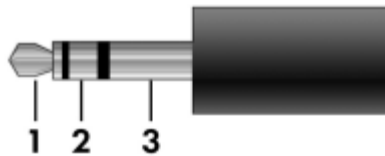
<b>Pin</b>	<b>Signal</b>	<b>Pin</b>	<b>Signal</b>
1	Unused	4	Unused
2	Tip	5	Unused
3	Ring	6	Unused

**Table D-6**  
**Audio-In (Microphone)**



Pin	Signal	Pin	Signal
1	Audio signal in	3	Ground
2	Audio signal in		

**Table D-7**  
**Audio-Out (Headphone)**



Pin	Signal	Pin	Signal
1	Audio out, left channel	3	Ground
2	Audio out, right channel		

---

## Power Cord Set Requirements

### 3-Conductor Power Cord Set

The wide range input feature of the computer permits it to operate from any line voltage from 100 to 120 or 220 to 240 volts AC.

The power cord set included with the computer meets the requirements for use in the country where the equipment is purchased.

Power cord sets for use in other countries must meet the requirements of the country where the computer is used.

## General Requirements

The requirements listed below are applicable to all countries.

- The length of the power cord set must be at least 1.5 m (5.0 ft) and a maximum of 2.0 m (6.5 ft).
- All power cord sets must be approved by an acceptable accredited agency responsible for evaluation in the country where the power cord set will be used.
- The power cord sets must have a minimum current capacity of 10 amps and a nominal voltage rating of 125 or 250 V AC, as required by each country's power system.
- The appliance coupler must meet the mechanical configuration of an EN 60 320/IEC 320 Standard Sheet C13 connector for mating with the appliance inlet on the back of the computer.

## Country-Specific Requirements

### 3-Conductor Power Cord Set Requirements

Country/Region	Accredited Agency	Applicable Note Number
Australia	EANSW	1
Austria	OVE	1
Belgium	CEBC	1
Canada	CSA	2
Denmark	DEMKO	1
Finland	FIMKO	1
France	UTE	1
Germany	VDE	1
Italy	IMQ	1
Japan	METI	3



#### NOTES:

1. The flexible cord must be <HAR> Type HO5VV-F, 3-conductor, 1.0 mm<sup>2</sup> conductor size. Power cord set fittings (appliance coupler and wall plug) must bear the certification mark of the agency responsible for evaluation in the country where it will be used.
2. The flexible cord must be Type SPT-3 or equivalent, No. 18 AWG, 3-conductor. The wall plug must be a two-pole grounding type with a NEMA 5-15P (15 A, 125 V) or NEMA 6-15P (15 A, 250 V) configuration.
3. The appliance coupler, flexible cord, and wall plug must bear a "T" mark and registration number in accordance with the Japanese Dentori Law. The flexible cord must be Type VCT or VCTF, 3-conductor, 1.00 mm<sup>2</sup> conductor size. The wall plug must be a two-pole grounding type with a Japanese Industrial Standard C8303 (7 A, 125 V) configuration.

### 3-Conductor Power Cord Set Requirements (*Continued*)

Country/Region	Accredited Agency	Applicable Note Number
Korea	EK	4
The Netherlands	KEMA	1
Norway	NEMKO	1
People's Republic of China	CCC	5
Sweden	SEMKO	1
Switzerland	SEV	1
Taiwan	BSMI	4
United Kingdom	BSI	1
United States	UL	2



**NOTES:**

1. The flexible cord must be <HAR> Type HO5VV-F, 3-conductor, 1.0 mm<sup>2</sup> conductor size. Power cord set fittings (appliance coupler and wall plug) must bear the certification mark of the agency responsible for evaluation in the country where it will be used.
2. The flexible cord must be Type SPT-3 or equivalent, No. 18 AWG, 3-conductor. The wall plug must be a two-pole grounding type with a NEMA 5-15P (15 A, 125 V) or NEMA 6-15P (15 A, 250 V) configuration.
3. The appliance coupler, flexible cord, and wall plug must bear a "T" mark and registration number in accordance with the Japanese Dentori Law. The flexible cord must be Type VCT or VCTF, 3-conductor, 1.00 mm<sup>2</sup> conductor size. The wall plug must be a two-pole grounding type with a Japanese Industrial Standard C8303 (7 A, 125 V) configuration.
4. The flexible cord must be Type RVV, 3-conductor, 0.75 mm<sup>2</sup> conductor size. Power cord set fittings (appliance coupler and wall plug) must bear the certification mark of the agency responsible for evaluation in the country where it will be used.
5. The flexible cord must be Type VCTF, 3-conductor, 0.75 mm<sup>2</sup> conductor size. Power cord set fittings (appliance coupler and wall plug) must bear the certification mark of the agency responsible for evaluation in the country where it will be used.

---

# Index

1394 port 1–11

## A

- all-in-one media cable, spare part number 3–18
- analog TV tuner, spare part number 3–18
- arrow keys 1–13
- audio troubleshooting 2–21
- audio Y-cable 2, spare part number 3–18
- audio-in jack
  - location 1–8
  - pin assignments D–6
- audio-out jack
  - location 1–8
  - pin assignments D–6

## B

- base enclosure
  - removal 5–41
  - spare part number 3–24, 5–41
  - spare part numbers 3–9
- battery
  - removal 5–6
  - spare part numbers 3–9, 3–22, 5–5

- battery bay 1–9, 1–18
- battery light 1–7
- battery release latch 1–18
- Bluetooth module
  - removal 5–46
  - spare part number 3–5, 3–20, 5–46
- Bluetooth module cable
  - illustrated 3–15
  - removal 5–47
- bottom components 1–18
- Bracket Kit
  - contents 3–7
  - spare part number 3–7, 3–22

## C

- Cable Kit
  - components 3–15
  - spare part number 3–15, 3–21
- cables, service considerations 4–2
- caps lock** key 1–13
- caps lock light 1–15
- CMOS clearing 1–4
- CMOS settings 1–4

- components
  - bottom 1–18
  - front 1–6
  - keyboard 1–12
  - left-side 1–9, 1–10
  - right-side 1–8
  - top 1–14, 1–16
- composite S-Video and audio cable, spare part number 3–18
- computer feet
  - illustrated 3–14
  - locations 5–11
- Computer Setup
  - Advanced Menu 2–5
  - Diagnostics Menu 2–4
  - File Menu 2–2
  - overview 2–1
  - Security Menu 2–3
- computer specifications 6–1
- computer, resetting 1–4
- connector pin assignments
  - external monitor D–4
  - headphone D–6
  - microphone D–6
  - monitor D–4
  - RJ-11 D–5
  - RJ-45 D–2
  - S-Video-out D–3
  - Universal Serial Bus (USB)
    - D–1
- connectors, service considerations 4–2
- D**
  - design overview 1–20
  - disassembly sequence chart 5–3
  - diskette drive
    - OS loading problems 2–19
    - precautions 4–3
  - display assembly
    - removal 5–27
    - spare part numbers 3–3, 3–22, 5–27
    - specifications 6–3
  - Display Hinge Kit
    - components 3–13, 5–31
    - spare part number 3–13, 3–21, 5–31
  - display hinge, removal 5–39
  - display inverter board
    - removal 5–36
    - spare part number 3–13, 3–21, 5–31, 5–36
  - Display Label Kit, spare part number 3–13, 3–23, 5–31
  - display panel
    - removal 5–36
    - spare part numbers 3–21
  - Display Panel Kit, spare part number 3–13, 5–31, 5–36
  - Display Plastics Kit
    - components 3–13, 5–31
    - spare part number 3–13, 3–21, 5–31
  - display release button
    - location 1–7
    - removal 5–56
  - display release hook, removal 5–38



Display Screw Kit, spare part number 3-13, 3-21, 5-31  
drive light 1-7  
drives, preventing damage 4-3  
DVB-T TV tuner antenna, spare part number 3-18, 3-24  
DVB-T TV tuner, spare part number 3-18, 3-23  
DVD/CD-RW Combo Drive  
precautions 4-3  
spare part numbers 3-5, 3-17, 3-24, 5-19  
specifications 6-6  
DVD±RW and CD-RW Combo Drive  
precautions 4-3  
spare part numbers 3-5, 3-17, 3-24, 5-19  
specifications 6-8

**E**

electrostatic discharge 4-4, 4-8  
expansion port 2 1-11  
expansion product  
troubleshooting 2-14  
ExpressCard assembly  
removal 5-76  
spare part number 3-5, 3-22, 5-76  
ExpressCard slot 1-8  
ExpressCard slot bezel 3-14  
external monitor port  
location 1-10  
pin assignments D-4

**F**

**F1** to **F12** keys 1-13  
fan assembly  
removal 5-69  
spare part number 3-9, 3-21, 5-69  
features 1-2  
feet  
illustrated 3-14  
locations 5-11  
flowcharts, troubleshooting  
no audio 2-21, 2-22  
no network/modem connection 2-26  
no OS loading 2-15  
no OS loading from diskette drive 2-19  
no OS loading from hard drive 2-16, 2-17, 2-18  
no OS loading from optical drive 2-20  
no power 2-8, 2-10, 2-11  
no video 2-12, 2-13  
nonfunctioning device 2-23  
nonfunctioning docking device 2-14  
nonfunctioning keyboard 2-24  
nonfunctioning pointing device 2-25  
**Fn** key 1-13  
front components 1-6

**G**

grounding equipment and methods 4–7

**H**

hard drive  
OS loading problems 2–16  
precautions 4–3  
removal 5–7  
spare part numbers 3–9,  
3–17, 3–22, 3–23, 5–7  
specifications 6–4

hard drive bay 1–19

hard drive cover  
illustrated 3–14  
removal 5–8  
spare part number 3–7,  
3–9, 3–14, 3–24, 5–8

headphone jack  
location 1–8  
pin assignments D–6

headset, spare part number  
3–19, 3–20

heat sink  
removal 5–62  
spare part number 3–9,  
3–21, 5–62

**I**

I/O address specifications  
6–12

interrupt specifications 6–10

**K**

keyboard  
removal 5–24  
spare part numbers 3–3,  
3–23, 5–24  
troubleshooting 2–24

keyboard components 1–12

keypad keys 1–13

**L**

Label Kit, spare part number  
3–18, 3–21

labels area 1–18

LED board  
removal 5–60  
spare part number 3–3,  
3–24, 5–60

left-side components 1–9,  
1–10

**M**

mass storage devices, spare  
part numbers 3–16

media cable, spare part number  
3–18

memory map specifications  
6–15

memory module  
removal 5–12  
spare part numbers 3–11,  
3–20, 3–22, 5–12

Memory Reader 1–11

Memory Reader light 1–11

- memory/Mini PCI module
  - compartment cover
    - illustrated 3–14
    - location 1–19
    - removal 5–13
  - microphone jack
    - location 1–8
    - pin assignments D–6
- Mini PCI communications module
  - removal 5–16
  - spare part numbers 3–11, 3–20, 5–16
- modem connector cable
  - illustrated 3–15
  - removal 5–51
- modem jack
  - location 1–8
  - pin assignments D–5
- modem module
  - troubleshooting 2–26
- monitor port
  - location 1–10
  - pin assignments D–4
- N**
- network jack
  - location 1–11
  - pin assignments D–2
- network, troubleshooting 2–26
- nonfunctioning device,
  - troubleshooting 2–14, 2–23
- num lock** key 1–13
- num lock light 1–15
- O**
- optical drive
  - location 1–8, 1–18
  - OS loading problems 2–20
  - precautions 4–3
  - removal 5–19
  - spare part numbers 3–5, 3–17, 5–19
  - specifications 6–6
- P**
- packing precautions 4–5
- password clearing 1–4
- password, resetting 1–4
- PC Card assembly
  - removal 5–73
  - spare part number 3–5, 3–22, 5–73
- PC Card eject button 1–11
- PC Card slot 1–11
- PC Card slot bezel, illustrated 3–14
- plastic parts 4–2
- Plastics Kit
  - components 3–14
  - spare part number 3–7, 3–14, 3–21
- pointing device,
  - troubleshooting 2–25
- power button 1–15
- power connector 1–8
- power connector cable
  - illustrated 3–15
  - removal 5–50
  - spare part number 3–5, 3–15, 3–24, 5–50

- power cord
  - set requirements E-2
  - spare part numbers 3-19, 3-20, 3-21
- power light 1-7
- power management features 1-5
- power supply, spare part number 3-18, 3-20
- power, troubleshooting 2-8
- precautions
  - diskette drive 4-3
  - DVD/CD-RW Combo Drive 4-3
  - DVD±RW and CD-RW Combo Drive 4-3
  - hard drive 4-3
  - optical drive 4-3
- processor
  - removal 5-65
  - spare part numbers 3-7, 3-20, 3-22, 3-24, 5-65

## **R**

- removal
  - preliminaries 4-1
  - procedures 5-1
- replacement
  - preliminaries 4-1
  - procedures 5-1
- RF cable, spare part number 3-18
- RF input adapter cable, spare part number 3-18
- right-side components 1-8
- RJ-11 jack
  - location 1-8
  - pin assignments D-5
- RJ-45 jack
  - location 1-11
  - pin assignments D-2
- RTC battery
  - removal 5-18
  - spare part number 3-11, 3-22, 5-18
- Rubber Pad Kit, spare part number 3-18, 3-21

## **S**

- Screw Kit
  - contents A-1
  - spare part number 3-19, 3-21, A-1
- screw listing A-1
- SD Memory Card, spare part numbers 3-11, 3-20, 3-21
- security cable slot 1-10
- serial number 3-1, 5-2
- service considerations 4-2
- speakers
  - location 1-7
  - removal 5-55
  - spare part number 3-9, 3-21, 5-55
- specifications
  - computer 6-1
  - display assembly 6-3
  - DVD/CD-RW Combo Drive 6-6
  - DVD±RW and CD-RW Combo Drive 6-8

- hard drive 6–4
  - I/O addresses 6–12
  - interrupts 6–10
  - memory map 6–15
  - optical drive 6–6
  - system DMA 6–16
  - static shielding materials 4–8
  - S-Video-out jack
    - location 1–10
    - pin assignments D–3
  - switch cover
    - removal 5–22
    - spare part numbers 3–3, 3–22, 5–22
  - system board
    - removal 5–48
    - spare part numbers 3–7, 3–24, 5–48
  - system DMA 6–16
  - system memory map 6–15
- T**
- thermal paste
    - replacement 5–64
    - spare part number 3–22, 5–62, 5–65
  - tools required 4–1
  - top components 1–14, 1–16
  - top cover
    - removal 5–41
    - spare part numbers 3–3, 3–22, 5–41
  - TouchPad bracket, spare part number 3–3, 3–22
  - TouchPad buttons 1–17
  - TouchPad cable
    - illustrated 3–15
    - spare part number 3–3, 3–21
  - TouchPad horizontal scroll zone 1–17
  - TouchPad vertical scroll zone 1–17
  - TouchPad, location 1–17
  - transporting precautions 4–5
  - troubleshooting
    - audio 2–21
    - Computer Setup 2–1
    - expansion product 2–14
    - flowcharts 2–6
    - keyboard 2–24
    - modem 2–26
    - network 2–26
    - nonfunctioning device 2–14, 2–23
    - OS loading 2–15
    - overview 2–1
    - pointing device 2–25
    - power 2–8
    - video 2–12
  - TV tuner remote control, spare part number 3–18
- U**
- Universal Serial Bus (USB) port
    - location 1–8, 1–11
    - pin assignments D–1
  - unknown password 1–4
  - USB digital drive, spare part number 3–17, 3–19, 3–20

- USB infrared receiver, spare part number 3–18
- USB travel mouse, spare part number 3–19, 3–20
- USB/audio board
  - removal 5–52
  - spare part numbers 3–9, 3–24, 5–52
- USB/audio board cable
  - illustrated 3–15
  - removal 5–52

## **V**

- vent, locations 1–9, 1–19
- video troubleshooting 2–12
- volume buttons 1–15

## **W**

- Windows applications key 1–13
- Windows logo key 1–13
- wireless antenna
  - disconnecting 5–17, 5–28
  - spare part number 3–13, 5–31
- wireless button 1–15
- workstation precautions 4–6