

**TravelMate™ 7100 Series  
Notebook Computer  
User's Guide**

## Copyright

This is a product of Acer Inc. developed to TI specifications. Acer and the Acer logo are registered trademarks and TravelMate is a trademark of Acer Inc. Texas Instruments, TI and the TI logo are registered trademarks of Texas Instruments Inc. Microsoft, Windows, and the Windows logo are registered trademarks of Microsoft Corporation. Intel and Pentium are registered trademarks of Intel Corporation. All other brands/product names are trademarks or registered trademarks of their respective companies.

No part of this publication may be reproduced, transmitted, transcribed, stored in a retrieval system, or translated into any language or computer language, in any form or by any means, electronic, mechanical, magnetic, optical, chemical, manual or otherwise, without the prior written permission of this company.

© 1997 by this company. All rights reserved.

## Disclaimer of Warranties

This company makes no representations or warranties, either expressed or implied, with respect to the contents hereof and specifically disclaims the implied warranties of merchantability or fitness for a particular purpose. Any software described in this manual is sold or licensed “as is.” Should the programs prove defective following their purchase, the buyer (and not this company, its distributor, or its dealer) assumes the entire cost of all necessary servicing, repair, and any incidental or consequential damages resulting from any defect in the software. Further, this company reserves the right to revise this publication and to make changes from time to time in the contents hereof without obligation to notify any person of such revision or changes.

# About This User's Guide

The following conventions are used in this manual:



Notes related to the current topic



Warnings about actions that can cause damage.



Cautions that help you avoid problems



Important reminders.



Tips or shortcuts.



# Contents

---

<b>Getting Started</b> .....	<b>1</b>
Unpacking Your Computer .....	1
Taking Care of Your Computer .....	2
Cleaning .....	3
AC Adapter .....	3
Battery Pack .....	4
Powering Up Your Computer .....	5
Entering User Information.....	6
Creating Backup and Startup Diskettes ..	6
Using Diskettes.....	7
Travel Tips .....	8
Getting Help.....	10
Technical Support.....	10
World Wide Web.....	10
<b>System Tour</b> .....	<b>11</b>
Feature Summary .....	11
Performance .....	11
Multimedia and Communications .....	12
Ergonomics.....	12
Expandability .....	12
Display .....	14
Opening and Closing the Display .....	14
FlashStart Automatic Power-On.....	14
Indicator Lights.....	15
Keyboard.....	17
Lock Keys .....	18
Embedded Keypad .....	20
Windows 95 Keys.....	22
Hot Keys.....	23
Touchpad.....	28
Automatic Tilt.....	31
Palm Rest .....	33

# Contents

---

Storage .....	34
Hard Disk .....	34
Module Bay.....	34
Ejecting a CD.....	35
Using the Floppy Drive Module	
Externally .....	35
Swapping Modules.....	38
Audio .....	40
Audio Control .....	41
Ports .....	42
Rear Panel Ports .....	42
Left Panel Ports.....	45
Security .....	48
System Resource Lock .....	48
<b>Power .....</b>	<b>42</b>
Battery Pack .....	49
Removing and Installing the	
Battery Pack .....	50
Charging the Battery.....	51
Checking the Battery Level.....	53
Optimizing Battery Life .....	55
Low-Battery Warning .....	56
Advanced Power Management .....	59
Heuristic Power Management .....	60
Suspend to Disk .....	61
Suspend to Memory .....	62
<b>Peripherals and Options .....</b>	<b>56</b>
Printers.....	64
PC Cards.....	65
Audio Devices .....	67
External Monitor .....	68
External Keyboard.....	69
External Keypad.....	70
External Pointing Device .....	71

# Contents

---

Mini Dock .....	73
Floppy Drive Cable .....	75
PS/2 Y-Bridge Cable .....	76
File Transfer Cable .....	77
Battery Pack .....	78
AC Adapter .....	78
Memory Upgrades .....	79
Hard Disk Upgrades.....	82
<b>System Utilities .....</b>	<b>76</b>
Sleep Manager .....	85
Accessing Sleep Manager .....	86
Creating Reserved Space.....	88
Removing a Reserved Space .....	90
Minimizing Sleep Manager .....	91
Exiting Sleep Manager .....	92
Sleep Manager Troubleshooting Tips ...	92
Uninstalling Sleep Manager .....	93
Touchpad Driver .....	95
BIOS Setup Utility.....	96
About My Computer.....	97
System Configuration .....	99
Advanced System Configuration.....	102
Power Saving Options .....	108
System Security.....	110
Reset To Default Settings .....	116
<b>Appendix .....</b>	<b>104</b>
Troubleshooting .....	117
Startup Error Messages.....	125
Specifications.....	127
System Memory Map.....	132
I/O Address Map.....	132
Interrupts .....	133
DMA Channels.....	134
IMPORTANT SAFETY INSTRUCTIONS .....	135

# Contents

---

Canadian DOC Notice .....	137
FCC Class B Radio Frequency Interference Statement .....	138
<b>Index .....</b>	<b>123</b>



# Getting Started

---

Congratulations on your purchase of the TravelMate 7100 series notebook computer. Guaranteed and backed by world-class support, you can be sure of top-notch performance from your new computer. This section guides you through the first few steps in setting up your computer.

## Unpacking Your Computer

Carefully unpack the carton and remove the contents. You should find your computer and an accessory box containing the following items:

- AC adapter
- Battery pack
- Floppy drive module
- External floppy drive cable
- Software library and recovery CD
- This user's guide and other documentation

If any of the items is missing or damaged, contact your dealer immediately.



---

**Caution: Be sure to read the Important Safety Instructions in the Appendix at the back of this manual.**

---

## Taking Care of Your Computer

Your notebook will serve you well if you observe the following guidelines:

- Do not expose the notebook to prolonged direct sunlight, or sources of heat, such as a radiator.
- Do not expose the notebook to temperatures below 32°F (0°C) or above 122°F (50°C).
- Do not subject the notebook to magnetic fields.
- Do not expose the notebook to rain or excessive moisture.
- Do not subject the notebook to heavy shock or vibration.
- Do not expose the notebook to dust and dirt.
- Do not place objects on top of the notebook when it is closed.
- Do not use the notebook on uneven surfaces.

## Cleaning

Before cleaning the notebook, always disconnect all power to the computer as follows:

1. Close the display lid to turn the notebook off.
2. Disconnect the AC adapter.
3. Remove the battery pack.

To clean the notebook case, use a soft cloth moistened with water. Do not use liquid or aerosol cleaners.



---

**Warning! Contact your dealer or see your service technician if the notebook is dropped or damaged in any way, or if liquid is spilled on the notebook.**

---

## AC Adapter

The AC adapter provides power to your notebook and charges the battery pack. Here are some ways of taking care of the AC adapter:

- Do not connect the adapter to any device except the notebook.
- Do not step on the power cord or place heavy objects on top of it. Carefully route the power cord and any cables away from foot traffic.
- When unplugging the power cord, pull on the plug and not on the cord.

# Getting Started

## Battery Pack

The long-lasting Lithium-Ion rechargeable battery pack provides power to your notebook on the go. Here are some things to keep in mind regarding the battery pack:

- ❑ Do not expose the battery pack to temperatures above 122°F (50°C).
- ❑ Use the battery pack only with the TravelMate 7100 series computer.
- ❑ Replace the battery pack only with the same type (model BTP-S31).
- ❑ Consult your local regulations or waste disposal provider for any local restrictions on the disposal or recycling of batteries.



---

**Warning! Do not open or disassemble the battery pack. Handle a damaged or leaking lithium-ion battery with extreme care. If the battery is damaged, electrolyte can leak from the cells and can cause injury.**

---

## Powering Up Your Computer

Powering up the computer is as easy as 1-2-3:

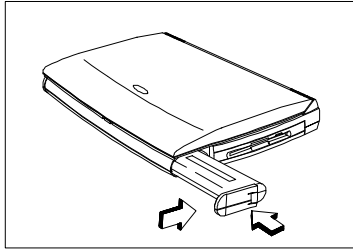

1. **Insert the Battery Pack.** Insert the battery pack into the battery compartment and slide the battery compartment cover toward the rear of the notebook until the compartment cover snaps closed.



# Getting Started

## Entering User Information

When Windows 95 loads for the first time, enter your user information. Have your Windows 95 authentication number ready. (You can find this number in the Windows 95 documentation package.)

## Creating Backup and Startup Diskettes

Windows 95 prompts you to create backup and startup diskettes.



---

**Note:** If your Windows 95 package contains a Windows 95 CD, you do not need to create backup diskettes for Windows 95. However, you should still create a Windows 95 startup disk.

---

## Using Diskettes

Follow these guidelines when using diskettes with your computer:

- ❑ Always make backup copies of diskettes that contain important data or program files.
- ❑ Keep diskettes away from magnetic fields and sources of heat.
- ❑ Avoid removing a diskette from the drive when the floppy drive activity light is on.
- ❑ Write-protect diskettes to prevent accidental erasure. To do this, slide the write-protect tab to the write-protect (open) position so that you can see through the tab opening.

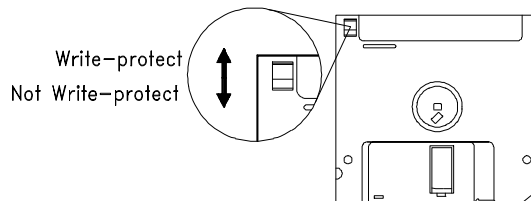

- ❑ When you label a diskette, be sure the label is firmly attached and completely within the diskette's label area (the area with the slight surface depression). An improperly attached label can cause the diskette to stick in the drive.

## Travel Tips

Here are some tips on preparing your computer for traveling:

1. Make diskette or tape backup copies of important files on the hard disk.
2. Close the display, making sure the cover latch is secure.
3. Disconnect the AC adapter and all peripherals.
4. Place the notebook, AC adapter, extra battery pack and other accessories you might need (such as modules and documentation) in a carrying bag.
5. Hand-carry your notebook. Do not check it in as luggage!



---

**Caution: The notebook can pass through airport X-ray equipment, but metal detectors can damage the notebook's hard disk.**

---

6. Check with your airline if you plan to use your computer onboard the aircraft.
7. Check that the voltage and power specifications of the country you are traveling in are compatible with the computer's AC adapter. If necessary, purchase a power cord that is compatible with the local AC voltage. Do not use converter kits sold for appliances to power the notebook.



# Getting Started

- 8.** If you are using a modem, check that if the telecommunications system of the country you are traveling in is compatible with the modem and its connector.

# Getting Started

## Getting Help

This user's guide provides clear and concise information about your computer, so read it thoroughly.

### Technical Support

Should you ever have a problem with your TravelMate, or if you think something is not working properly, call our technical support at (800) 816-2237. Please have handy your system serial number and system model number. You can also contact the local dealer or distributor in the country you are traveling infor assistance.

### World Wide Web

If you have access to the Internet, visit our home page on the World Wide Web at <http://www.acer.com/>. There you'll find the latest information about our products, as well as updates on software drivers and utilities.

The Travelmate 7100 combines high-performance, versatility, multimedia capabilities, and an advanced power management system in a unique ergonomic and stylish case.

## Feature Summary

The computer is packed with features that make it as easy to work with as it is to look at. Here are some of the computer's features:

### Performance

- ❑ Intel Pentium® processor with MMX™ technology
- ❑ 64-bit main memory and 512KB external (L2) cache memory
- ❑ Large display in active-matrix TFT
- ❑ PCI local bus video with 128-bit graphics accelerator
- ❑ Flexible module bay (3.5-inch floppy drive or CD-ROM drive or optional second hard disk)
- ❑ High-capacity, Enhanced-IDE hard disk
- ❑ An advanced power management system with two power-saving modes
- ❑ Lithium-Ion smart battery pack
- ❑ High-speed connectivity

# System Tour

## Multimedia and Communications

- ❑ 16-bit stereo audio with built-in FM synthesizer and 3D sound effect
- ❑ Built-in microphone and dual angled stereo speakers
- ❑ Support for simultaneous display on the built-in screen and an external monitor for presentations
- ❑ Full-screen, 30 frames per second, true-color MPEG video playback
- ❑ Infrared wireless communication

## Ergonomics

- ❑ Intuitive FlashStart automatic power-on
- ❑ Sleek, smooth and stylish design
- ❑ Full-sized, full-function keyboard
- ❑ Wide and comfortable palm rest
- ❑ Ergonomically-positioned touchpad pointing device

## Expandability

- ❑ CardBus PC Card (PCMCIA) slots (two type II/I or one type III) with Zoomed Video port function
- ❑ Mini-dock option with built-in CardBus slots (two type II/I or one type III)
- ❑ USB port onboard
- ❑ Upgradeable memory and hard disk

## Display

The computer's large graphical display offers excellent viewing, with quality and performance equal to desktop displays.



---

**Note:** The computer is available with an active matrix TFT display.

---

## Opening and Closing the Display

To open the display, slide the display lid latch to the right and lift up the lid. Then tilt it to a comfortable viewing position. To close the display, fold the lid down gently until the display lid latch clicks into place.



---

**Warning!** To avoid damaging the display, do not slam the lid when closing it. Do not place anything on top of the computer when the display is closed.

---

## FlashStart Automatic Power-On

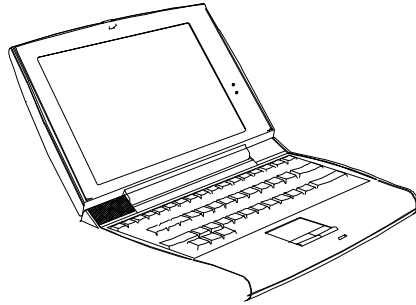

The computer has no on/off switch. Instead it uses a lid switch, located near the center of the display hinge, that turns the computer on and off automatically.

# System Tour

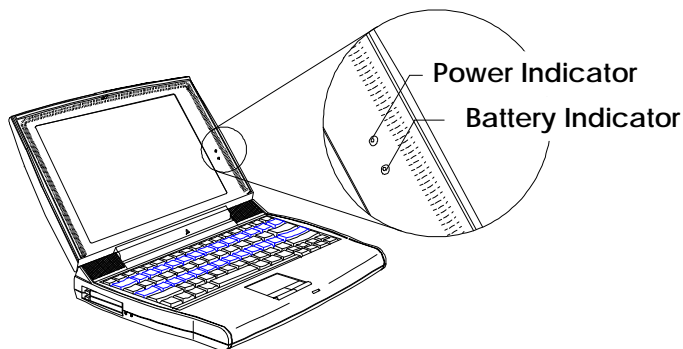

# System Tour



Indicator Light	Icon	Description
Power Indicator		Lights when power is on.  Flashes when the computer is in suspend-to-memory mode.
Battery Indicator		Lights when the battery pack is charging.  Flashes when battery power is low.



## Keyboard

The computer's full-size keyboard includes lock keys, an embedded keypad with cursor-control keys, Windows keys, twelve function keys that act as "hot keys" when used in combination with the special Fn key.

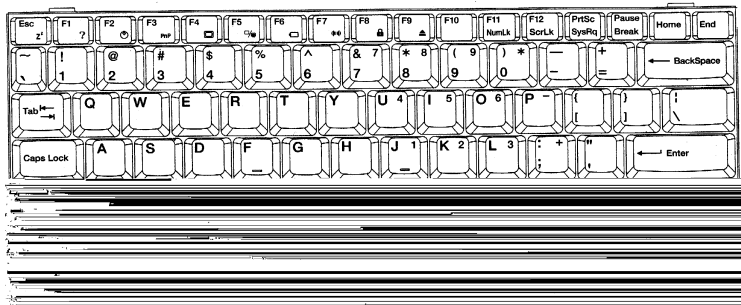

The keyboard also includes a built-in touchpad pointing device, an automatic tilt feature, and a comfortable palm rest to provide optimum ergonomics.

### Lock Keys

The computer keyboard contains three lock keys that act as toggles: Caps Lock, NumLk, and ScrLk. NumLk and ScrLk require using the Fn key as part of a key combination. The first time you press one of these keys or key combinations, you turn on its function; the next time, you turn off its function, and so on.

# System Tour



**Tip:** When entering a lot of numeric data, toggle on NumLk or attach an external keypad as described on page 70.

Key	Description
Caps Lock	When Caps Lock is on, alphabetical characters appear in uppercase as you type them.
Fn+NumLk (Fn+F11)	When Num Lock After Boot is enabled in the BIOS setup utility (see page 101) and Num Lock is on, the embedded keypad is in numeric mode. The keys function as a numeric keypad, complete with arithmetic operators +, -, *, and /—just like the keypad on a standard keyboard.
Fn+ScrLk (Fn+F12)	When Scroll Lock is on, the screen moves up or down one line when you press the ↑ or ↓ key. (Scroll Lock may not work in some applications.)

## Embedded Keypad

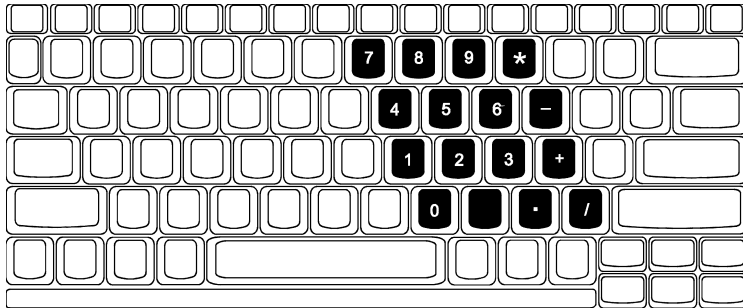

The embedded keypad functions like a desktop numeric keypad. It is marked by small characters printed in the upper right corner of the keycaps. (For simplicity, cursor-control symbols are not printed on the keycaps.)







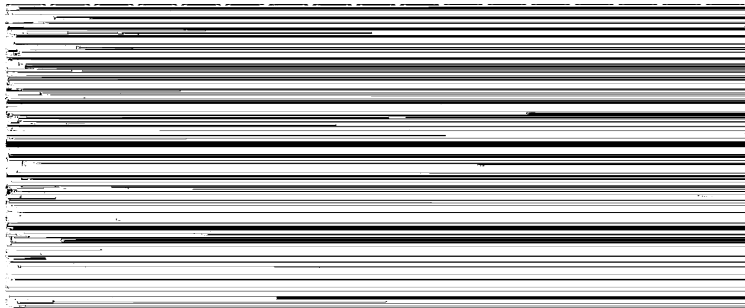

To Use	With NumLk On	With NumLk Off
Numeric keys	Use the keypad keys in the usual way	Press and hold Fn and Shift while using the keypad keys
Cursor-control keys	Press and hold Shift while using the keypad keys	Press and hold Fn while using the keypad keys
Main keyboard keys (letters, etc.)	Press and hold Fn while using the keypad keys	Use the keypad keys in the usual way

# System Tour

## Windows 95 Keys

The computer keyboard contains two keys that perform Windows 95-specific functions:  and .



Key	Description
 key	The same as clicking the Windows 95 Start button. Pressing other keys in combination with the  key performs special functions:
 +Tab	Activate the next taskbar button
+E	Explore My Computer
+F	Find Document
+M	Minimize All
Shift+  +M	Undo Minimize All
 +R	Display Run dialog box
 key	Opens an application's context menu. (The same as the touchpad's right button.)

## Hot Keys

The computer's special Fn key, used in combination with other keys, provides "hot-key" combinations that access system control functions, such as screen contrast, brightness, volume output, and the BIOS setup utility.



---





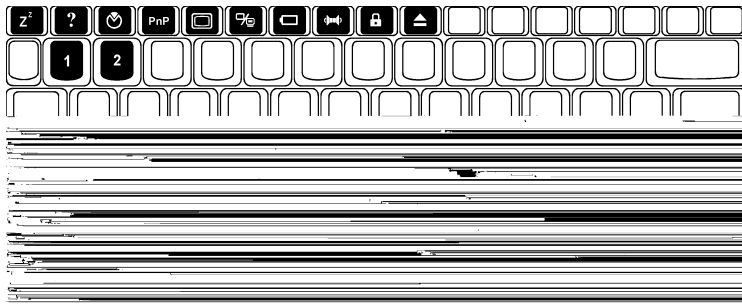

**Note:** When using hot-key combinations, press and hold the Fn key before pressing the other key in the combination.

---













Hot Key	Icon	Function	Description
Fn+Esc	Z <sup>^</sup>	Suspend-to-memory	Enters suspend-to-memory mode
Fn+F1	?	Help	Displays the hot-key list
Fn+F2	⏻	Setup	Enters the BIOS setup utility
Fn+F3	PnP	Plug and Play Configuration	Performs system configuration for Plug and Play operating systems like Windows 95

# System Tour

Hot Key	Icon	Function	Description
Fn+F4		Screen Blackout	Blanks the screen to save power; to wake up the screen, press any key
Fn+F5		Display Toggle	Switches display from the built-in display, to an external monitor, to both built-in and external if one is connected
Fn+F6		Fuel Gauge On/Off	Toggles battery gauge display on and off. The gauge shows the battery charge percentage.  Shows a plug icon if a powered AC adapter is connected to the computer; shows a speaker icon if speaker output is on (Fn+F7); shows a T icon if turbo mode is on (Fn+2)
Fn+F7		Speaker On/Off	Toggles speaker output on and off
Fn+F8		Lock System Resources (Password Lock)	Locks the computer and requires a password to unlock it
Fn+F9		Eject	Accesses the eject menu described on page 27
Fn+Ctrl+↑		Volume Up	Increases speaker volume

# System Tour

Hot Key	Icon	Function	Description
Fn+Ctrl+↓		Volume Down	Decreases speaker volume
Fn+Ctrl+→		Balance Right	Shifts speaker balance to the right
Fn+Ctrl+←		Balance Left	Shifts speaker balance to the left
Fn+  ↑		Brightness Up	Increases screen brightness
Fn+  ↓		Brightness Down	Decreases screen brightness
Fn+  →		Contrast Up	Increases screen contrast (not available for TFT displays)
Fn+  ←		Contrast Down	Decreases screen contrast (not available for TFT displays)
Fn+↑		Fuel Gauge Up	With the fuel gauge displayed, moves the fuel gauge up
Fn+↓		Fuel Gauge Down	With the fuel gauge displayed, moves the fuel gauge down
Fn+→		Fuel Gauge Right	With the fuel gauge displayed, moves the fuel gauge right
Fn+←		Fuel Gauge Left	With the fuel gauge displayed, moves the fuel gauge left
Fn+1		CD Eject	Ejects the CD-ROM drive
Fn+2		Turbo Mode On/Off	Toggles turbo mode on and off

# System Tour

## Eject Menu

The Fn+F9 hot-key combination brings up a special eject menu that allows you to perform several system configuration functions.

Eject Options:

```
Battery (Suspend-to-disk) ..... Change
CD-ROM Disc (Also Fn+1) ..... Eject
Mini Dock (Suspend) ..... Change
Power Off ..... Change
```

↑↓ = Move Highlight Bar, ↵ = Select, ESC = Exit

Select...	To...
Battery (Suspend to Disk)	Store all current data and system information to the hard disk.
CD-ROM Disc (Also Fn+1)	Open the CD-ROM drive (eject a CD).
Mini Dock (Suspend)	Undock the computer. Press the dock lock and pull the dock handle toward you to undock the computer. (See the mini dock manual for details.) Once the computer is successfully undocked, press any key to resume.
Power Off	Turn the computer off. If you are using Windows 95, use the Shutdown command to turn off your computer.



## Touchpad

The ergonomically-positioned touchpad is a pointing device that senses movement on its surface. The pointer moves on the screen in response to the movement of your finger on the surface of the touchpad.

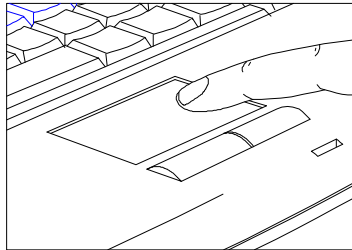

- ❑ Move your finger across the touchpad to move the pointer on the screen.
- ❑ Press the left and right buttons located at the lower edge of the touchpad to “click.” These buttons correspond to the left and right buttons on a mouse.
- ❑ Alternatively, simply tap on the touchpad to “click.”

# System Tour

Function	Left Button	Right Button	Tapping on the Touchpad
Execution	Double-click		Tap twice quickly
Selection	Click once		Tap once
Drag	Click and hold to drag the pointer		Tap twice quickly, holding your finger to the touchpad on the second tap to drag the pointer
Access Context Menu		Click once	

To change Touchpad or pointer characteristics, see page 95.



---

**Notes:**

Keep your fingers and the touchpad dry and clean when using the touchpad.

The touchpad is sensitive to finger movements. Hence, the lighter the touch, the better the response. Tapping too hard will not increase the touchpad's responsiveness.

The touchpad works with most mouse drivers. However, the touchpad driver supports special functions that work uniquely with the touchpad. We recommend you use the touchpad driver instead of any other mouse driver.

---

## Automatic Tilt

On models with a 12.1-inch display, the computer can automatically tilt the keyboard to a six-degree angle whenever you open the lid to provide a comfortable typing angle similar to desktop keyboards.



---

**Tip:** The automatic tilt feature and the palm rest described on the next page help prevent repetitive strain injury to your wrists and fingers.

---

# System Tour

To set the automatic tilt feature, follow these steps:

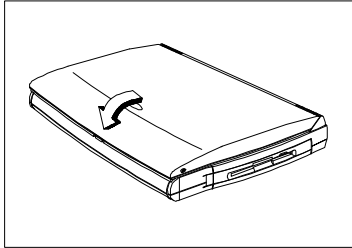

1. Close the lid.

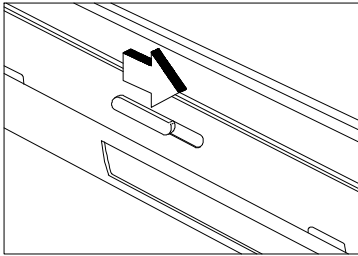

2. To enable the automatic tilt feature, slide the tilt switch, located above the port cover on the rear of the computer, to the right.

3. To disable the automatic tilt feature, slide the tilt switch to the left.

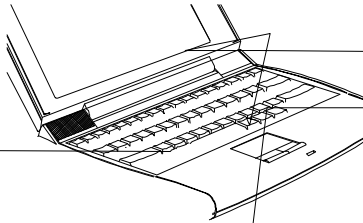

## Palm Rest

The curved palm rest located below the keyboard provides a comfortable place to rest your hands as you type.

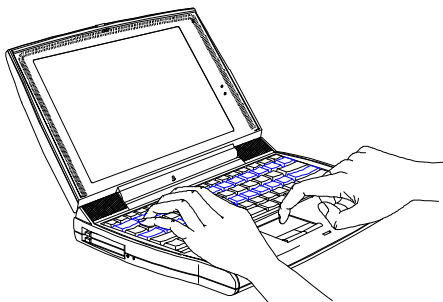

## Storage

The computer provides high-capacity storage on a 2.5-inch Enhanced-IDE hard disk. The computer also contains a bay that accepts removable modules—a CD-ROM drive, a floppy drive or a second hard disk option.

### Hard Disk

The hard disk can be upgraded when you need more storage space. See page 82.

### Module Bay

The computer's module bay accommodates a CD-ROM drive module or a 3.5-inch floppy drive module or an optional second hard disk. Other modules may be available — consult your dealer for details.

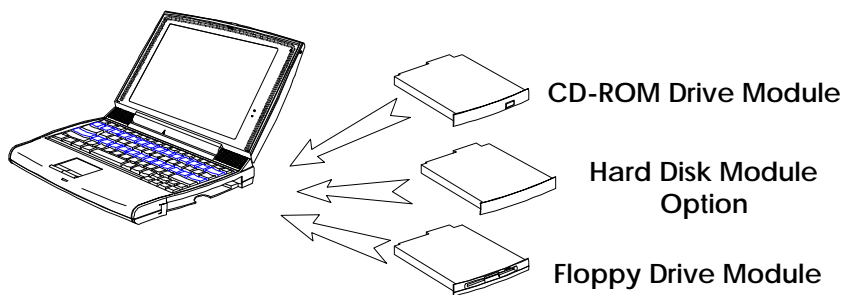

The CD-ROM drive module gives you portable multimedia access. The floppy drive module can be used as an internal or external unit. The optional second hard disk gives you more storage space.

## Ejecting a CD

To eject a CD, press Fn+1 or press the eject button on the CD-ROM drive, or use your software application's CD eject command. (There may be a few seconds delay before the CD is ejected.)

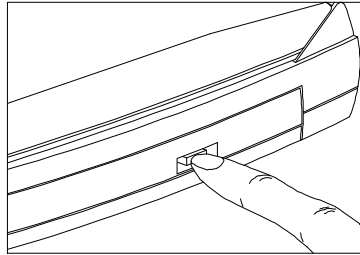

---

**Tip:** To eject a CD using Windows 95, double-click My Computer, right-click the CD-ROM drive icon, and select the Eject command from the context menu that appears.

---

## Using the Floppy Drive Module Externally

You can use the floppy drive module externally when a CD-ROM drive module is installed in the module bay.



---

**Warning!** You cannot use the CD-ROM drive module externally. Only the floppy drive module can be used externally.

---

# System Tour

To use the floppy drive module externally, follow these steps:

- 1.** If the floppy drive module is installed in the module bay, remove it by following the steps described in the next section.
- 2.** Open the port cover on the rear of the computer, and connect the 25-pin connector end of the floppy drive cable to the computer's parallel port.
- 3.** Connect the other end of the cable to the floppy drive module.

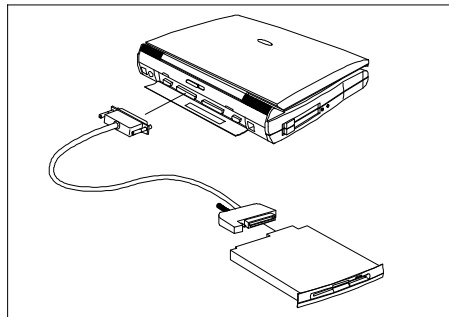



## Swapping Modules

Follow these steps to swap modules:

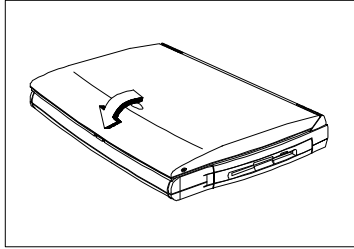

1. Click the Windows 95 Start button and select Shut Down to shut down your computer.
2. When Windows finishes shutting down, close the display.

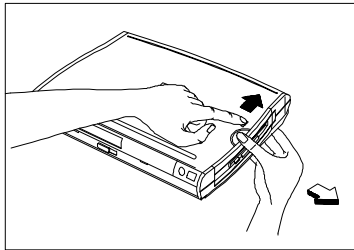

3. Turn the computer over and locate the module release lock on the bottom of the computer. With one hand, slide and hold the lock in the direction of the arrow. With the other hand, press the module's half-moon-shaped latch to release it and pull out the module.

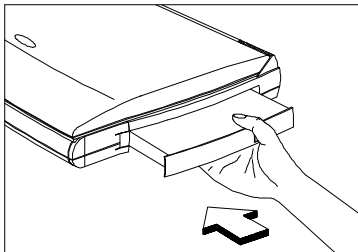

4. Insert the new module securely into the module bay until it snaps into position.
5. Restart your computer.

## Audio



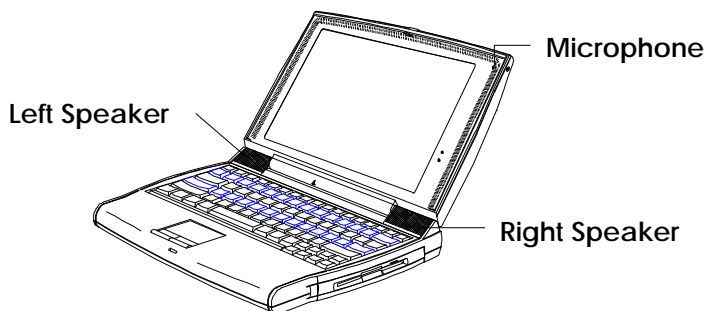

The computer includes 16-bit stereo audio with a built-in FM synthesizer, dual, angled speakers, a built-in sensitive microphone, and two audio ports on the computer's left panel for external audio devices. *For information on connecting external audio devices, see page 67.*

The dual, angled speakers are located on both sides of the display hinge and direct sound toward you, creating a unique audio chamber that produces excellent sound quality. The built-in microphone uses both front- and side-pickup that provides excellent quality audio recording.



## Audio Control

The computer provides several hot keys that allow you to control audio output:

Hot Key	Icon	Function	Description
Fn+F7		Speaker On/Off	Toggles speaker output on and off
Fn+Ctrl+↑		Volume Up	Increases speaker volume
Fn+Ctrl+↓		Volume Down	Decreases speaker volume
Fn+Ctrl+→		Balance Right	Shifts speaker balance to the right
Fn+Ctrl+←		Balance Left	Shifts speaker balance to the left



**Caution: Audio settings you make with hot keys are in effect only for a single session—that is, until you turn off the computer. To change settings for all sessions, use the audio controls in Windows 95.**

# System Tour

## Ports

The computer's ports allow you to connect peripheral devices to your computer just as you would to a desktop PC. The main ports are found on the computer's rear panel. The computer's left panel contains the computer's multimedia ports and PC card slots.

### Rear Panel Ports



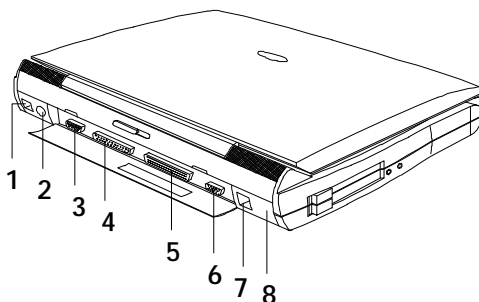



The computer's rear panel contains the computer's main ports and connectors as shown in the illustration below.



- 1 DC-in Port
- 2 PS/2 Port
- 3 Serial Port
- 4 Parallel Port

- 5 Mini Dock Connector
- 6 External CRT Port
- 7 USB Port
- 8 Infrared Port

# System Tour

Port	Icon	Connects to...
DC-in port		AC adapter and power outlet
PS/2 port		PS/2-compatible device (PS/2 keyboard, keypad, mouse)
Serial port (UART16650- compatible)		Serial device (serial mouse)
Parallel port (EPP/ECP- compliant)		Parallel device (parallel printer, external floppy drive)
Mini dock connector		Mini dock
External CRT port		

# System Tour

## Fast Infrared (FIR) Port

The computer's FIR (fast infrared) port located on the rear panel allows you to transfer data to IR-aware machines without cables. For example, you can transfer data between two IR-capable computers, or send data to an IR-aware printer without using a cable.

The infrared port is IrDA-compliant, and can transfer data at speeds of up to 4 megabits per second (Mbps) at a distance of up to one meter.

To use the infrared port, position two IR-aware devices such that their IR ports are no more than one meter apart and offset no more than 15 degrees.

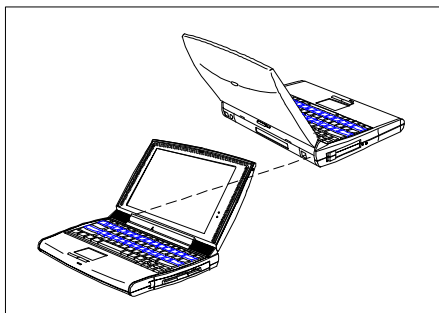

When the two computers are in position, simply begin the data transfer as you normally would. See your file transfer software for details.

## Left Panel Ports

The computer's left side panel contains the computer's multimedia ports and PC card slots, as shown in the illustration on the next page.

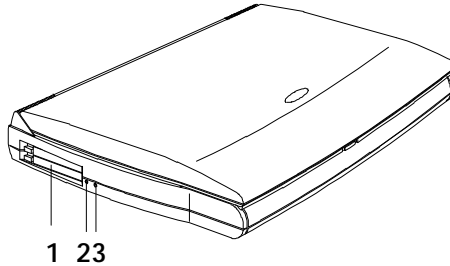

- 1 PC Card Slots
- 2 Microphone-in/Line-in Port
- 3 Speaker-out/Line-out Port

Port	Icon	Connects to...
PC Card slots		Two type I/II PC Cards or one type III Card
Microphone-in/ Line-in	Ⓜ	External microphone or line input device
Speaker-out/ Line-out	Ⓜ	Amplified speakers or headphones

## PC Card Slots

The computer contains two PC card slots on the left panel that accommodate two type I/II or one type III PC card(s). Consult your dealer for available PC card options. For information on how to use the PC card slots, see page 65.

## Multimedia Ports

The computer provides a Mic-In/Line-in port and a Speaker-out/Line-out port on the left panel to accommodate multimedia audio devices, such as a microphone, speakers, or headphones. For information on how to connect audio devices, see page 67.



---

### Notes:

Connecting external audio devices to the computer's multimedia ports automatically shuts off the corresponding internal audio device. For example, if you connect external speakers, the internal speakers automatically shut off.

If you connect an audio device to the Mic-in or Line in port, make sure to adjust the appropriate input from the mixer. See the multimedia section of your Windows 95 manual.

---



## Security

The computer includes both hardware and software features to secure your computer. A hardware security notch located on the left panel of the computer lets you connect a standard key-based computer security lock.

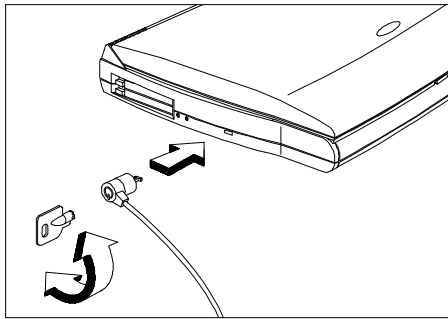

Circle or wrap a computer security lock cable around an immovable object such as a table or locked drawer handle. Then insert the lock into the notch and turn the key to secure the lock.

## System Resource Lock

A two-level password scheme protects your computer from unauthorized access. When set, just press **Fn+F8** to lock all system resources. In this situation, no one can access the computer without entering the correct password. *For more information about setting and using passwords, see page 111.*

The computer operates on AC or battery power. This section contains the information you need to know to operate the computer on battery power. This section also includes information about the computer's unique power management system.

## Battery Pack

The computer uses a single high-capacity Lithium-Ion smart battery pack that gives you longer use between charges. The battery pack includes the following features:

- ❑ *Lithium-Ion Technology.* Lithium-ion technology does not have the memory-effect problem of nickel-cadmium (NiCd) batteries, nor the temperature problem of nickel-metal-hydride (NiMH) batteries. Lithium ion batteries consistently provide the longest battery life and the best solution for road warriors.
- ❑ *Battery Gauge.* The battery pack contains a built-in gauge that allows you to check the battery charge level even when the battery is not installed inside the computer.
- ❑ *Battery-Low Warning.* When the battery charge level becomes low, the battery indicator flashes at regular intervals, warning you that the battery pack's power is low and needs to be recharged.



---

**Tips:**

Whenever possible, use the AC adapter. The battery will come in handy when you travel or during a power failure. It is advisable to have an extra fully-charged battery pack available for backup.

If the computer is to be stored for more than two weeks, it is best to remove the battery pack. Battery power from a fully charged battery pack depletes in roughly a week with the computer in suspend-to-memory mode.

---



---

**Warning! Do not expose the battery pack to temperatures below 32°F (0°C) or above 140°F (60°C).**

---

## Removing and Installing the Battery Pack

To remove the battery pack, follow these steps:

1. Turn off the computer, or connect the AC adapter to the computer.
2. Press the battery compartment cover latch and slide it toward the front of the computer.
3. Pull out the battery pack.

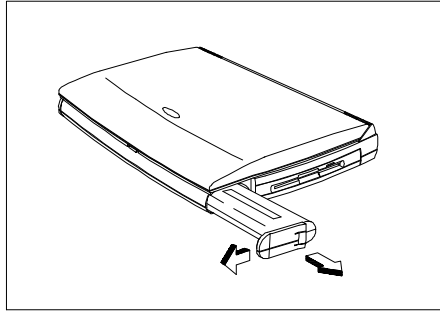

To install the battery pack, simply reverse the procedure as follows:

- 1.** Insert the battery pack into the battery compartment.
- 2.** Slide the battery compartment cover latch toward the rear of the computer until it snaps into position.

## Charging the Battery

To charge the battery, place the battery pack inside the battery compartment and plug the AC adapter into the computer and an electrical outlet. Depending on the state of the battery and how the computer is being used, the computer uses one of three charging modes: Rapid Charge, Charge-In-Use, and Trickle Charge.

## Rapid Charge

The computer uses rapid charge when the computer is in suspend mode with a powered AC adapter connected. Using rapid charge, a depleted battery charges fully in approximately two hours.

## Charge-In-Use

The computer uses charge-in-use when the computer is in use with a powered AC adapter connected. Using charge-in-use, a depleted battery charges fully in approximately four hours.

## Trickle Charge

When the battery is fully charged and a powered AC adapter is connected, the computer uses trickle charge to maintain the battery charge and prevent the battery from draining while the computer is in use.



---

**Tip:** We suggest that you charge the battery pack while you sleep. For example, charging the battery the night before traveling provides a fully charged battery for use the next day.

---

## Checking the Battery Level

The computer provides three ways to check the battery charge level:

- With the onscreen fuel gauge
- With the Windows 95 battery indicator

- ❑ With the battery-pack gauge

## Onscreen Fuel Gauge

The onscreen fuel gauge provides a graphic representation and shows the percentage of the present battery level. To view the onscreen fuel gauge, press Fn+F6. (If a powered AC adapter is connected, a plug icon shows in the onscreen fuel gauge.)

Press and hold Fn and the cursor keys to move the fuel gauge around the screen. Press Fn+F6 again to hide the fuel gauge.



---

**Note:** When the battery is charged to the maximum, it shows a 99% charge. If you see a ??% charge, it means a battery is not installed.

---

## Windows 95 Battery Indicator

Rest the pointer on the taskbar battery icon to display the current power level. (If a powered AC adapter is connected, a plug icon replaces the battery icon on the taskbar.) Double-click the taskbar icon to display the Power dialog box. You can also access this dialog box via the Power icon from Control Panel.

## Battery Pack Gauge

The battery pack gauge allows you to check the battery charge level when it is not installed in the computer. Simply press the fuel gauge button on the battery pack.

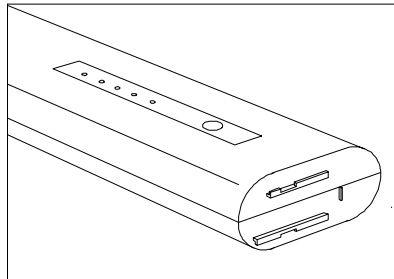

The lights on the fuel gauge show the charge level as follows:

Lights (LEDs) Lit	Charge Level
●●●●●	100%
●●●●○	≈80%
●●●○○	≈60%
●●○○○	≈40%
●○○○○	≈20%
*○○○○ (blinking)	<20%

## Optimizing Battery Life

The battery pack can be recharged approximately 500 times. Follow these suggestions to optimize battery life and maximize battery power:

- Purchase an extra battery pack.

- ❑ Set the When Lid is Closed parameter to Suspend to Disk. *See page 108.*
- ❑ Use the AC adapter whenever possible, reserving the battery for on-the-go computing.
- ❑ Keep the battery pack in the computer when the computer is powered by the AC adapter. A constant trickle charge maintains the battery level. The charge-in-use function also charges the battery pack.
- ❑ Set the Display Always On parameter to Disabled to save power. *See page 109.*
- ❑ Eject any PC card from the card slot when not in use because PC cards draw extra power.
- ❑ Store the battery pack in a cool, dry place when not in the computer. The higher the storage temperature, the faster the battery pack discharges. The recommended storage temperature is 40° to 86°F (10° to 30°C).

## Low-Battery Warning

You don't have to be concerned about battery power when you use the computer with the AC adapter connected. However, when you operate the computer on battery power, pay attention to the battery indicator (). When less than 10 percent charge is left in the battery, the following signals warn you of the low-battery condition:



- ❑ The battery indicator (  )

## **soon as possible to prevent data loss.**

The following table gives you the recommended courses of action when you encounter a low-battery warning.

<b>Situation</b>	<b>Recommended Action</b>
AC adapter and power outlet are available	<ol style="list-style-type: none"><li>1. Connect the AC adapter to the computer to begin charging the battery.</li><li>2. Resume work.</li></ol> <p>If you want the battery to recharge faster, close the display or press Fn+Esc (<b>Z</b>) to enter suspend mode.</p>
An extra fully-charged battery pack is available	<ol style="list-style-type: none"><li>1. Press Fn+F9.</li><li>2. Select Battery and press Enter to enter suspend to disk mode.</li><li>3. After the computer has powered off, open the battery compartment cover.</li><li>4. Remove the used up battery pack.</li><li>5. Install the new battery pack.</li><li>6. Press any key or open the display to resume work.</li></ol> <p>Remember to recharge the old battery pack.</p>
AC adapter, power outlet or extra battery pack is not available	Close the display to enter suspend mode.

## Advanced Power Management

The computer supports the Advanced Power Management (APM) standard defined by Microsoft and Intel.



---

**Tip:** Advanced Power Management greatly prolongs battery life. Use APM whenever possible.

---

To use Advanced Power Management, follow these steps:

1. Click the Start button and select Settings, Control Panel.
2. Double-click the Power icon in Control Panel.
3. Set the power management mode to Advanced.

If you do not see the Power icon in Control Panel, refer to your Windows user's manual for details.

## Heuristic Power Management

The computer uses a new power management technique called Heuristic Power Management (HPM) to take advantage of APM's power-saving features without degrading performance. HPM allows the computer to provide maximum power conservation and maximum performance.

Power-management methods used by most computers are timer-based. You set time-out values for the display, the hard disk, and other devices. The system then puts itself to sleep when it detects inactivity that exceeds the times you set. The problem with this is that no two users are alike. Each of us has his or her own habits when using the computer, which makes timer-based power management ineffective.

HPM is a “self-learning” method. With HPM, the system manages its power according to the way you use the machine. In effect, the computer delivers maximum power when you need it, and saves power when you don't need the maximum—all without any intervention from you. There are no timers to set, nothing to enable or disable. The HPM system figures out everything for you.

Using HPM, the computer automatically suspends its operations—that is, enters suspend mode—in response to a hot key or in response to various events and conditions. Depending on the When Lid Is Closed setting in the BIOS setup utility (see page 108), the system enters one of two suspend modes:

- Suspend to Disk
- Suspend to Memory



---

**Note:** If an external monitor is connected to the computer, the computer does not enter either suspend mode when you close the display. To enter suspend mode, disconnect the external monitor, and then open and reclose the display.

---

## Suspend to Disk

Upon entering suspend-to-disk mode, the computer stores all current data and system information on the hard disk in a file created by the Sleep Manager utility (see page 85). Upon return to normal mode, the computer restores the data from the hard disk and resumes where you left off.

If the When Lid Is Closed setting in the BIOS setup utility is set to Suspend To Disk and the suspend-to-disk file created by Sleep Manager is present and valid, the computer automatically enters suspend-to-disk mode when:

- You close the display

- ❑ Battery power becomes low while the computer is in suspend-to-memory mode
- ❑ The battery fails without a powered AC adapter connected



---

**Caution: If the battery runs out of power while the AC adapter is not connected, the computer enters suspend-to-disk mode, regardless of the When Lid Is Closed setting.**

---

The computer exits suspend-to-disk mode and returns to normal mode when you open the display. (Make sure a charged battery pack is installed and/or a powered AC adapter is connected before you open the display.)

## Suspend to Memory

Upon entering suspend-to-memory mode, the computer stores all current data and system information in memory. Upon return to normal mode, the computer restores the data from memory and resumes where you left off.

If the When Lid Is Closed setting in the BIOS setup utility is set to Suspend To Memory, the computer automatically enters suspend-to-memory mode when:

- ❑ You close the display
- ❑ You press the suspend hot key Fn+Esc (**Z**)
- ❑ There is sustained inactivity

- ❑ The battery fails without a powered AC adapter connected



---

**Note:** The computer also enters suspend-to-memory mode whenever an attempt to suspend to disk fails—for example, if the suspend-to-disk file is absent or invalid.

---

When the computer enters suspend-to-memory mode, the power indicator (🔌) flashes.

The computer exits suspend-to-memory mode and returns to normal mode when:

- ❑ You open the display
- ❑ You press any key
- ❑ Resume On Schedule is enabled in setup, and the selected date and time occur

*For information about Resume On Modem Ring and Resume On Schedule, see page 110.*

# Peripherals and Options

---

The computer provides excellent connectivity and expansion capabilities. This section describes how to connect peripherals and hardware options to the computer and how to upgrade your computer. (For a complete list of available options and upgrades, consult your dealer.)

## Printers

The computer supports both parallel and serial printers. To connect a parallel printer, plug the printer cable into the parallel port (🖨️) on the computer's rear panel.

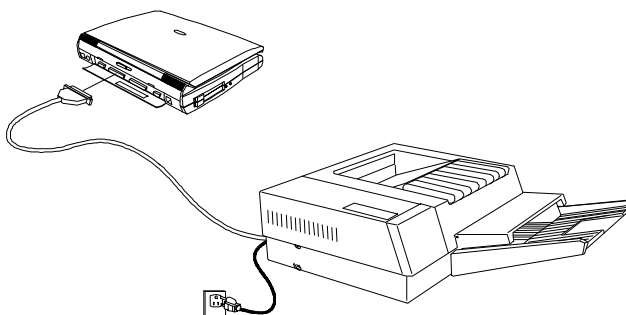

To connect a serial printer, plug the printer cable into the serial port (🔌) on the computer's rear panel.



# Peripherals and Options

## PC Cards

Credit-card-sized PC cards (PCMCIA cards) enhance the usability and expandability of your computer. The computer provides two type I/II PC Card slots (or one type III slot) on the computer's left side panel. Common type II cards include flash memory, SRAM, fax/data modems, LAN and SCSI cards. The type III cards most often used are 1.8-inch ATA drives and cellular modems.

The computer supports Zoomed Video port functionality which allows your computer to support hardware MPEG in the form of a ZV PC card.

To install a PC card:

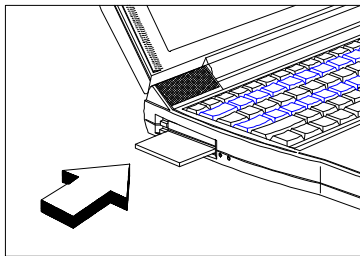

Insert a type I/II PC card into the desired slot, or insert a type III card or ZV card into the lower or bottom slot.

Refer to the card's user manual for details on how to install and use the card, including any cable connections needed, such as a network cable.

To eject a PC card, first exit the application that is using the card. Then:

# Peripherals and Options

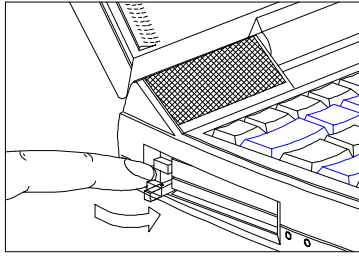

Flip out the slot eject  
button of the slot where  
the card is inserted

and ...

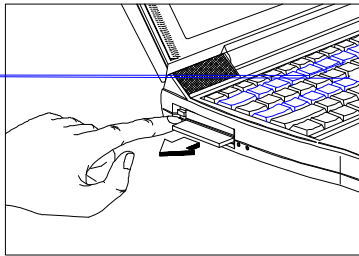

## Audio Devices

You can connect audio devices to the line-in (🔊) and line-out (🔊) ports on the computer's left panel. Use the line-in port to connect a 3.5-mm mini-jack microphone or other line-in device. Use the line-out port to connect external amplified speakers or headphones.

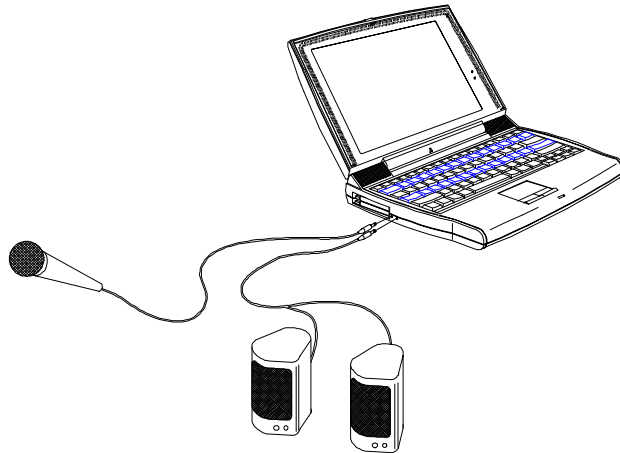

---

**Note:** When you connect a device to the line-in port, make sure to turn off the appropriate input from the mixer. For more information, see the multimedia section of your Windows 95 user's guide.

---

# Peripherals and Options

## External Monitor

You can connect an external monitor to the CRT port (📺) on the computer's rear panel. See your monitor manual for any additional instructions.

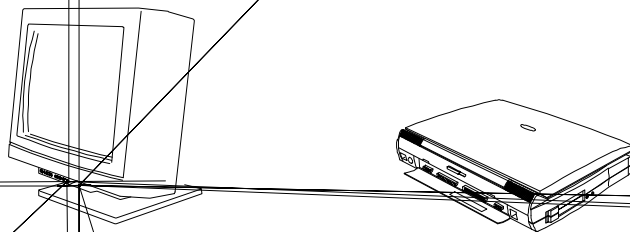

# Peripherals and Options

## External Keyboard

You can connect any PS/2-compatible keyboard to the computer. Simply plug the external keyboard into the PS/2 connector (Ⓜ ) on the computer's rear panel.





---

**Tip:** To connect two devices to the PS/2 port, such as an external keyboard and a mouse, use a PS/2 Y-bridge cable. See page 76.

---

# Peripherals and Options

## External Keypad

You can connect any PS/2-compatible numeric keypad to the computer. Simply plug the keypad into the PS/2 connector (   ) on the computer's rear panel.

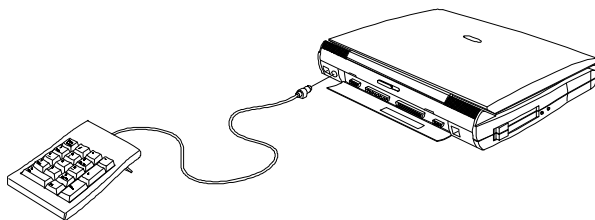

## External Pointing Device

You can connect a serial or PS/2-compatible mouse or similar pointing device to the computer. To connect a serial pointing device, plug the device into the serial port (Ⓜ) on the computer's rear panel.

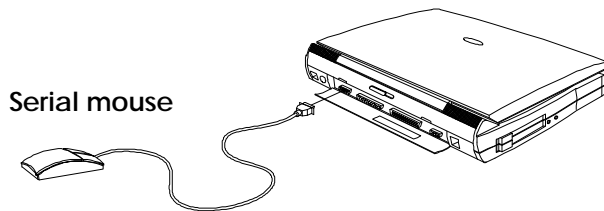

---

**Note:** To enable the serial mouse, use the Add New Hardware tool in the Windows 95 Control Panel.

---

To connect a PS/2-compatible pointing device, plug the device into the PS/2 port (Ⓜ) on the computer's rear panel.

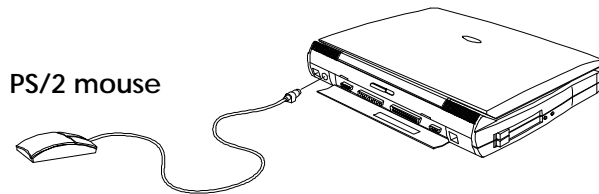

---

**Note:** Installing an external PS/2 pointing device disables the built-in touchpad.

---

# Peripherals and Options

## USB Devices

You can connect a USB (Universal Serial Bus) peripheral device to your computer. This peripheral standard allows you to connect USB devices to your computer without using up your system resources.

Most USB devices have a built-in USB port onto themselves which allows you to daisy-chain other USB devices.

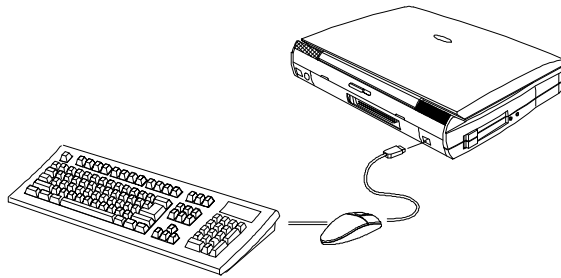



## Mini Dock

The mini dock allows you to connect your computer to various peripherals, and includes two additional CardBus slots. Consult your dealer for details. For connection instructions, see the guide included with the mini dock.



# Peripherals and Options

## Floppy Drive Cable

The floppy drive cable allows you to use your floppy drive module externally. To connect the cable, open the computer's rear port cover and connect the 25-pin connector end of the floppy drive cable to the computer's parallel port (☰). Then connect the other end to the floppy drive module.

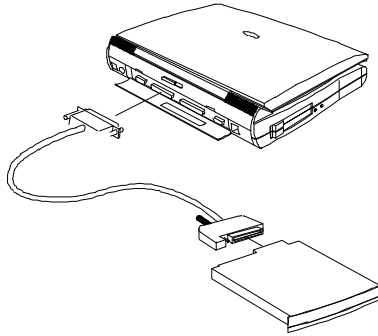

# Peripherals and Options

## PS/2 Y-Bridge Cable

The PS/2 Y-bridge cable allows you to connect a PS/2 mouse and a PS/2 keyboard to the computer's PS/2 port. Plug the single-connector end of the Y-bridge cable into the computer's PS/2 port. Then attach the connector with the mouse icon to the PS/2 mouse cable, and the connector with the keyboard icon to the PS/2 keyboard.

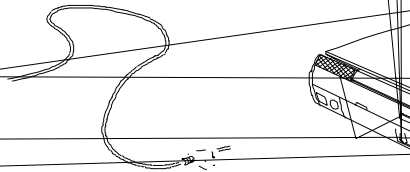

# Peripherals and Options

## File Transfer Cable

You can use the file transfer cable to transfer data between the computer and other computers. Connect one end of the file transfer cable to the parallel port (☞) on the computer's rear panel, and connect the other end to the other computer's parallel port. Then use your file transfer utility to perform the transfer.

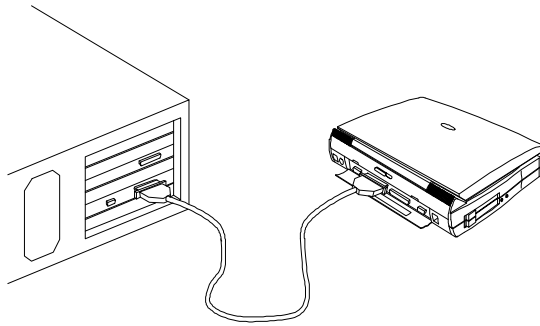

---

**Tip:** Use the computer's serial infrared (SIR) port to transfer data between the computer and another serial-aware computer. See page 45.

---

## Battery Pack

It is good practice to have a spare battery pack around, especially when you travel. The Li-Ion (lithium-ion) smart battery supplies more power than a conventional NiMH (nickel metal-hydride) battery. With power management, you get even more power on-the-go.

## AC Adapter

You can purchase an additional AC adapter for your computer or mini docking station.

# Peripherals and Options

## Memory Upgrades

Memory is upgradeable up to 128 MB, employing 64-bit soDIMMs (small outline Dual Inline Memory Modules) in 8, 16, 32 and 64 MB configurations. The following table lists the possible memory configurations.

Slot 1	Slot 2	Total Memory
16 MB	16 MB	32 MB
0 MB	32 MB	32 MB
32 MB	0 MB	32 MB
8 MB	32 MB	40 MB
32 MB	8 MB	40 MB
16 MB	32 MB	48 MB
32 MB	16 MB	48 MB
32 MB	32 MB	64 MB
0 MB	64 MB	64 MB
64 MB	0 MB	64 MB
8 MB	64 MB	72 MB
64 MB	8 MB	72 MB
16 MB	64 MB	80 MB
64 MB	16 MB	80 MB
32 MB	64 MB	96 MB
64 MB	32 MB	96 MB
64 MB	64 MB	128 MB

Both memory slots are accessible via a memory expansion door on the base of the computer.

# Peripherals and Options



---

**Caution:** When installing memory, we recommend you seek the help of a qualified service technician. Improper installation can damage the memory module or the computer.

---



---

**Warning!** Electronic components can be damaged by static electricity. To avoid damage, always wear a wrist grounding strap (available at most electronic stores) when handling electronic components. Do not remove the component from its anti-static packaging until you are ready to install it.

---

Follow these steps to install additional memory:

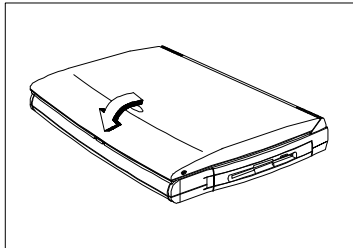

1. Power down your computer. If you are using the AC adapter, disconnect it from the power outlet.
2. Close the display lid.
3. Turn the computer over to access the base.

# Peripherals and Options

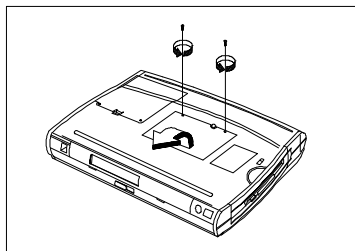

4. Remove two screws that secure the memory door and lift the door up.

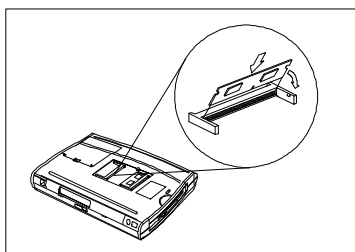

5. Insert the memory module diagonally into the slot, and then gently press down on the module until it clicks into place.

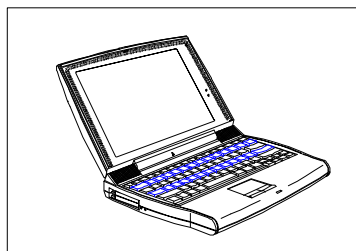

6. Replace the memory door and secure it with the screw.
7. Open the display to turn on the computer.

After new memory modules have been installed, the system automatically detects and reconfigures the total memory size.



## Hard Disk Upgrades

Larger capacity hard disks are available as an upgrade. The computer uses a 2.5-inch Enhanced-IDE hard disk. The following table shows the currently supported hard disks. Consult your dealer for additional hard disks that may be available.

Vendor	Model	Capacity	Cylinders	Heads	Sectors
IBM	DTCA 23240	3.0 GB	6304	16	63
IBM	DTCA 24090	4.0 GB	7944	16	63

Follow these steps to install a replacement hard disk:

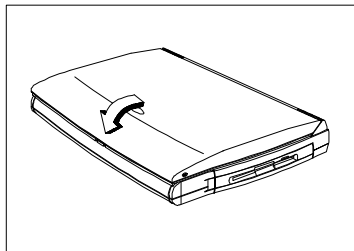

1. Power down your computer. If you are using the AC adapter, disconnect it from the power outlet.
2. Close the display lid.
3. Turn the computer over to access the base.

# Peripherals and Options

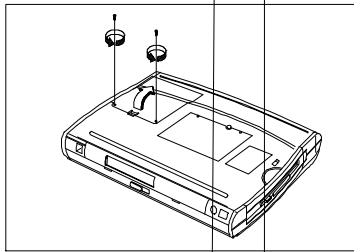

4. Remove two screws that secure the hard disk door; then press the hard disk door release latch and lift the door up.

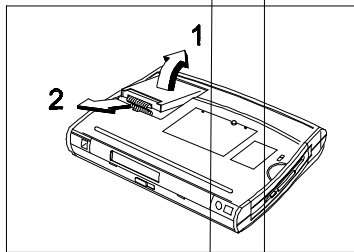

5. Lift up (1) and slide out (2) the hard disk.

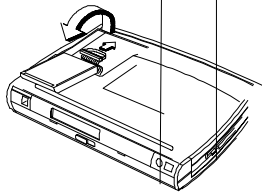

# Peripherals and Options



---

**Note:** An additional hard disk can also come in the form of a module that swaps with the floppy drive or CD-ROM drive in the module bay. Refer to your dealer for details.

---

The computer comes pre-loaded with the following system utilities and drivers:

- Sleep Manager suspend-to-disk utility
- Touchpad driver
- Display driver
- Audio driver
- System core logic driver
- File-transfer utility
- PC Card slot driver and application



---

**Note:** Your computer may also have several application programs pre-loaded. To access the application programs, click the Start button and select the application folder. Then click the program's icon. For help with an application program, consult the application's user manual or the program's online help.

---

## Sleep Manager

Sleep Manager is a utility that reserves a space on the hard disk for the computer's suspend-to-disk feature. It creates a contiguous area on the hard disk where the system saves your data and system information when the suspend-to-disk feature is activated.



**Note:** Sleep Manager starts and adjusts the space needed for suspend-to-disk mode automatically every time you start Windows 95. You do not need to access Sleep Manager for routine use of your computer.

## Accessing Sleep Manager

To access Sleep Manager, click the Windows 95 Start button. Then select Programs, 0V Suspend Utility, Sleep Manager. The main Sleep Manager window shown on the next page appears.

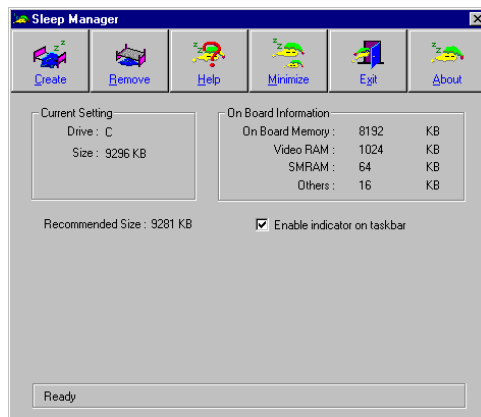

The Current Setting area shows the drive location and size of the current hard disk space reserved by Sleep Manager. The On Board Information area shows the system memory resources that will be stored when the system enters suspend mode. The total of these resources is the recommended size of the reserved hard disk space shown below the current setting area.

# System Utilities

The Enable Indicator on Taskbar check box allows you to choose whether or not a Sleep Manager status icon appears on the Windows 95 taskbar. Select this check box to enable the icon; clear the check box if you prefer not to see the Sleep Manager icon on the taskbar.



---

**Note:** The Sleep Manager taskbar icon appears with an exclamation point if Sleep Manager's reserved space has not been created, or if APM is not enabled. The icon appears with a red crossed circle if the space has not been created and APM is also not enabled. *For more information about APM, see page 59.*

---

When the Sleep Manager icon is displayed on the taskbar, you can display the current status of Sleep Manager by simply resting the mouse pointer on the icon. Or you can double-click the icon to access Sleep Manager,

## Creating Reserved Space

The Create button at the top of the Sleep Manager window tells Sleep Manager to find and reserve a contiguous area on the hard disk for use in suspend-to-disk mode.



---

**Note:** When suspend-to-disk mode is started, the system checks to see that space been reserved. If it has not (or the amount of system memory has been changed since a space was reserved), Sleep Manager starts automatically and begins the

# System Utilities

Click Ok to have Sleep Manager create the required space based on system information. Or, you can choose the location and size of the file. When you click Advanced, the following screen appears:

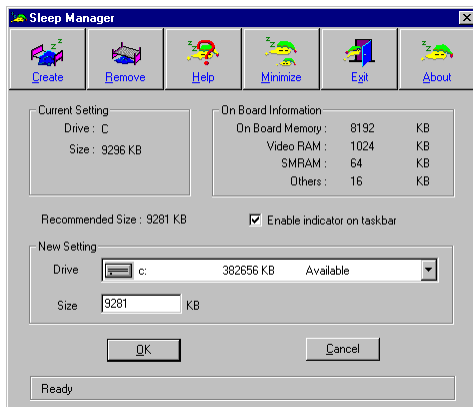

# System Utilities

Sleep Manager checks the system configuration and displays the recommended size. The drive where the space will be created is defined by the system and will be the first available logical drive which has the requested contiguous free disk space on it. The recommended size is the minimum size needed to save the current system status.

If Sleep Manager cannot find the required space on the hard disk during the space creation process, it displays the message “Not Enough Space for Allocation.”

## **Not Enough Space for Allocation**

When Sleep Manager creates the space on the hard disk, several situations can cause the appearance of the message Not Enough Space for Allocation:

- ❑ The amount of free space on the drive is less than Sleep Manager needs. If the total amount of free space on the drive is less than the recommended size shown on the Sleep Manger window, delete some unnecessary files from the hard disk to make room. Then re-run Sleep Manager.
- ❑ The hard disk has enough free space, but the free space exists as small fragments. The free disk space that Sleep Manager requires must be contiguous. To solve this problem, run the Windows 95 Disk Defragmenter utility. Then re-run Sleep Manager.



- ❑ You are using disk compression and the amount of free space on the uncompressed host drive is less than Sleep Manager needs. Sleep Manager works with most compression software. However, Sleep Manager can only create reserved space on the uncompressed host drive. If the free space on the host drive is small (as it usually is), use the appropriate commands in your compression software to enlarge the size of the host drive. Then re-run Sleep Manager.

## Removing a Reserved Space

If you want to use or take back Sleep Manager's reserved space, click Sleep Manager's Remove button.



---

**Caution: Removing Sleep Manager's reserved space prevents the system from entering suspend-to-disk mode, and is not recommended.**

---

When you click Sleep Manager's Remove button, the following dialog box appears:

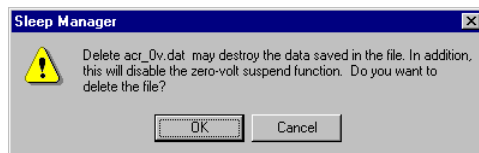

Click Ok to confirm that you want to delete the Sleep Manager file.

## Minimizing Sleep Manager

Click the Minimize button on Sleep Manager's window to minimize Sleep Manager and allow it to run in the background. If the Enable Indicator on Taskbar check box is selected, the Sleep Manager icon will appear on the taskbar. You can then restore the Sleep Manager window when you need it, by double-clicking the taskbar icon. If the Enable Indicator on Taskbar is not selected, you must click the Windows 95 Start menu and select Programs, 0V Suspend Utility, Sleep Manager to restore Sleep Manager.

## Exiting Sleep Manager

Select the Exit button to shut down Sleep Manager.



---

**Caution: Using the Exit button to shut down Sleep Manager disables the automatic adjustment of reserved disk space for suspend-to-disk operations, and is not recommended.**

---

## Sleep Manager Troubleshooting Tips

The following table lists some error messages you might see when using Sleep Manager and what to do about them.

# System Utilities

<b>Error Message</b>	<b>Solution</b>
BIOS not compliant with Sleep Manager.	Sleep Manager can run only on computers with a compatible BIOS.
This machine does not have a power management unit. You cannot run Sleep Manager without PMU.	Sleep Manager can only work on computers with a power management unit (PMU) installed.
The APM driver for Windows is not installed. Use Windows Setup to install the APM driver before you run Sleep Manager.	See page 59 for instructions on how to enable advanced power management (APM) on your computer.
Requested disk space is not enough /The created file is not contiguous.	See page 89 for information on how to solve disk space problems.
The [directory name] directory cannot be created. Enter another directory or try another drive.	The directory name you specified is not valid. (You can create only one subdirectory at a time.)
The software has not been successfully installed. You must run Setup again.	Sleep Manager is not completely installed. Re-install Sleep Manager.

## Uninstalling Sleep Manager

Uninstalling Sleep Manager removes the Sleep Manager utility from your hard disk.



---

**Caution: Uninstalling Sleep Manager does not remove the hard disk space reserved for suspend-to-disk mode. Therefore, you can still use the suspend-to-disk feature. However, uninstalling Sleep Manager prevents the automatic adjustment of reserved disk space, and is not recommended. (For information on how to remove the reserved hard disk space, see page 90.)**

---

To uninstall Sleep Manager, follow these steps:

1. Click the Windows 95 Start button, and select Programs, Sleep Manager, Sleep Manager.
2. Click Exit on the Sleep Manager main window to shut down Sleep Manager.
3. Click the Windows Start button, and select Settings, Control Panel.
4. Double-click the Add/Remove Programs icon in Control Panel.
5. On the Install/Uninstall tab, select Sleep Manager for Windows 95 and click Add/Remove.
6. Follow the screen instructions to complete the uninstallation.

## Touchpad Driver

The computer's built-in touchpad works with most mouse drivers, but the pre-loaded touchpad driver provides additional functions that work only with the touchpad.

To configure these additional functions, follow these steps:

- 1.** Click the Start button and select Settings, Control Panel.
- 2.** Double-click the Mouse icon.
- 3.** In the Mouse property sheet, select the TouchPad tab.

To see descriptions of the configuration options, move the pointer over the option and press the right touchpad button (right-click). When the What's This button appears, press the left touchpad button to bring up online help for that option.

## BIOS Setup Utility

The computer BIOS setup utility allows you to configure the computer and its hardware settings. The computer comes correctly configured, and you do not need to run the BIOS setup utility to use the computer. However, you might need to use the BIOS utility if you want to customize the way your computer works, or if you receive an error message after making hardware or software changes.

With the BIOS setup utility, you can:

- Check the system configuration
- Change the system date, time, or speed
- Change the system startup sequence
- Set the power-saving suspend mode
- Set or change resume options
- Set, change, or remove a system password

# System Utilities

Press Fn+F2 to access the BIOS setup utility. You will see the BIOS Utility main screen shown below.

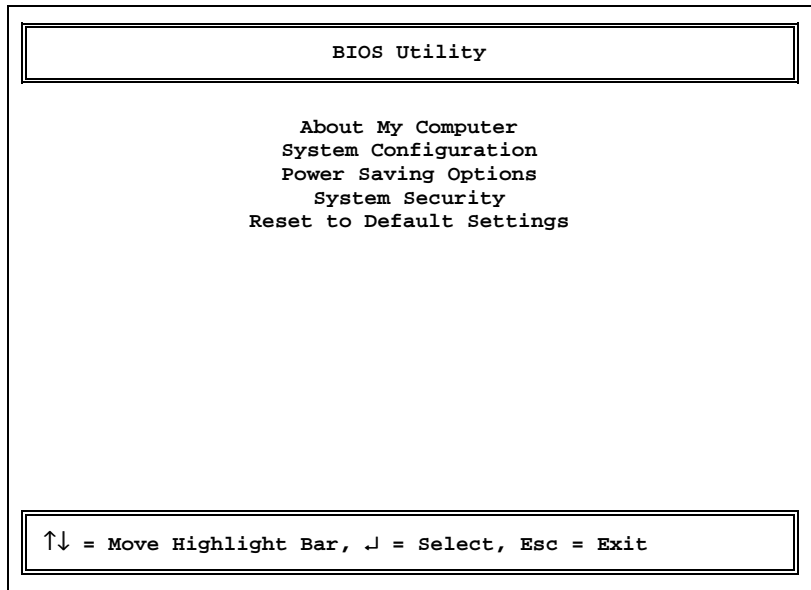

Press ↑ or ↓ to highlight the menu item you want. Then press Enter to access the highlighted item. Press Esc to exit.

## About My Computer

Selecting About My Computer presents you with two screens of details about the computer and its peripherals. These screens are for information only; you cannot change the settings on these screens.

# System Utilities

The following table tells you what each of the items on the About My Computer screens are.

Item	Description
System Architecture	System architecture information
System BIOS	BIOS version
System ID	ID information on major components
Processor	Processor type and speed
Coprocessor	Coprocessor type
Internal Cache (L1)	Internal cache size and whether it is enabled or not
External Cache (L2)	External cache size and whether it is enabled or not
Total Memory	Total memory size
Bank A	Bank A memory module size and type
Bank B	Bank B memory module size and type
<b>System Peripherals</b>	
Graphics Controller	Graphics controller type and video memory size
Display Output	Display type
Hard Drive 0	IDE 0 drive type and size (hard disk)
Hard Drive 1	IDE 1 drive type (CD-ROM or other IDE drives)
Floppy Drive A	Floppy drive A type
Floppy Drive B	Floppy drive B type



# System Utilities

Item	Description
<b>Expansion Peripherals</b>	
PCMCIA Slot 0	Card presence in slot 0 (detected by the socket service)
PCMCIA Slot 1	Card presence in slot 1 (detected by the socket service)
Parallel Port	Parallel port base address and IRQ
Serial Port	Serial port base address and IRQ
IrDA (FIR)	Infrared port base address and IRQ
Onboard USB	USB port if enabled or not
AC Adapter	Connected AC adapter information
Main Battery	Installed battery type information
<b>Onboard Audio</b>	
Base Address	Audio base address
MPU Base Address	Audio MPU-401 base address
IRQ Setting	Audio IRQ settings
DMA Channel	Audio DMA channels

# System Utilities

## System Configuration

Selecting System Configuration presents a Basic System Configuration screen, where you can change several items in your computer's configuration.

Press ↑ or ↓ to move from one item to another, and ← or → to change settings. Press F1 to get help on a selected item. Press Esc to exit the Basic System Configuration screen and return to the main BIOS Utility screen.

## Date and Time

The current date is in “Day-of-the-week Month Day, Year” format—for example, [Mon Aug 11, 1997]. The current time is in “Hour:Minutes:Seconds” format. The system uses a 24-hour clock—for example, 6:25:50 PM appears as 18:25:50.

## Floppy Drives

The default setting for Floppy Drive A is 1.44 MB 3.5-inch. Floppy Drive B is set to None, and it is only enabled if you connect an additional external floppy drive.

## Hard Disks

The Hard Disk 0 entry refers to the computer's internal hard disk. With this entry set to Auto, the BIOS automatically detects the hard disk and displays its capacity, cylinders, heads, and sectors. Other hard disk settings are configured automatically for optimum drive performance.

You can change the Hard Disk 0 entry to User if you want to enter drive settings manually. To determine your drive settings, check the data found on your hard disk or supplied in the hard disk vendor documentation.



---

**Caution: We suggest that you leave this parameter set to Auto to allow the BIOS to auto-detect the drive settings at each boot-up.**

---

The Hard Disk 1 entry is used when a CD-ROM drive module or second IDE drive option is installed in the module bay.

## Num Lock After Boot

When set to Enabled, Num Lock After Boot tells the computer to turn on Num Lock automatically on startup, activating the keyboard's embedded numeric keypad. The default setting is Disabled.

# System Utilities

## LCD Expansion Mode

When set to Enabled, LCD Expansion Mode allows full-screen views in DOS mode. The default setting is Disabled.

## Internal Speaker

This parameter lets you enable or disable the internal speaker. The default setting is Enabled.



---

**Tip:** You can also toggle the speaker on and off by pressing the speaker hot key combination Fn+F7.

---

## Silent Boot

When set to Enabled, the computer shows the computer logo onscreen and hides the POST routine messages. The default setting is Enabled.

## Fast Boot

When set to Enabled, the computer bypasses the memory tests to speed up the boot-up process. The default setting is Disabled.

## Advanced System Configuration

For advanced users, the System Configuration menu item contains two hidden pages that allow you to view and configure more technical aspects of the computer.



---

**Caution: The computer is already tuned for optimum performance and you should not need to access these advanced screens. If you do not fully understand the items in these special screens, do not change their values.**

---

To access the Advanced System Configuration screens, press F8 at the BIOS Utility main screen before selecting the System Configuration menu item. When you now select System Configuration and the Basic System Configuration screen appears, you will see “Page 1/3” in its upper right corner. Press PgDn to access page 2, the first Advanced System Configuration screen, and PgDn again to access page 3, the second Advanced System Configuration screen.



---

**Note:** F8 acts as a toggle on the BIOS Utility main screen. Each time you press F8 at the main screen, you toggle between accessing the single-screen Basic System Configuration and the three-screen Advanced System Configuration.

---

# System Utilities

## Internal Cache

Internal cache refers to cache built into the CPU. When enabled, this setting boosts system performance. It is also called CPU cache or L1 (level one) cache. The default setting is Enabled.

## External Cache

External cache greatly increases system performance by lessening the load on main memory. It is also called L2 (level 2) cache. The default setting is Enabled.

## Enhanced IDE Features

The Enhanced IDE Features section includes four parameters for optimizing hard disk performance. These performance features depend on drive support. Newer drives support most or all of these features.

- Hard Disk Size > 504MB.** If your hard disk size is greater than 504MB and you use DOS or Windows, set this parameter to Auto. If you use NetWare, UNIX, or Windows NT, set this parameter to Disabled. The default setting is Auto.

- ❑ **Multiple Sectors Read/Write.** This parameter enhances hard disk performance by reading/writing more data at once. The available values are: Auto or Disabled. The default Auto setting allows the system to adjust itself to the optimum read/write setting.
- ❑ **Advanced PIO Mode.** Advanced PIO (Programmed Input/Output) Mode enhances drive performance by optimizing the hard disk timing. The available values are: Auto and Mode 0. The default setting is Auto.
- ❑ **Hard Disk 32 Bit Access.** This parameter allows your hard disk to use 32-bit access. The available values are: Auto and Disabled. The default setting is Auto.



---

**Tip:** We suggest you set all of these parameters to Auto whenever that choice is available. This allows the computer to use the hard drive at the highest possible performance level.

---

## Onboard Communication Ports

The Onboard Communication Ports section allows you to set addresses and interrupts for the computer's serial and parallel ports.

- ❑ **Serial Port.** The Serial Port parameter can be set to Enabled or Disabled. The Base Address parameter accepts the following values: 3F8h, 2F8h, 3E8h or 2E8h. The IRQ parameter accepts 4 or 11.

# System Utilities

The default values are Enabled, 3F8h and 4.

- ❑ **IrDA (FIR).** The IrDA (FIR) parameter can be set to Enabled or Disabled. The Base Address parameter accepts the following values: 3F8h, 2F8h, 3E8h or 2E8h. The IRQ parameter accepts 3 or 10. The DMA Channel parameter accepts 3, 0 or 1.

The default values are Enabled, 2F8h, 3 and 3.

- ❑ **Parallel Port.** The Parallel Port parameter can be set to Enabled or Disabled. The Base Address parameter accepts 378h or 278h. The IRQ parameter accepts 7 or 5. The Operation Mode parameter accepts the following values: EPP, ECP, Bi-directional or Standard. The ECP DMA Channel parameter lets you set the DMA channel used in ECP mode. You must choose DMA channel 1 or 3 with this parameter if you select ECP as your parallel port operation mode.



---

**Note:** If ECP is selected, the IR port functions at SIR (serial infrared) speed which is 115.2 kbps.

---

The default values are Enabled, 378h, 7 and EPP.



---

**Caution:** In order to prevent resource conflicts, the BIOS Utility does not allow you to set the same IRQ and address values for different devices.

---



## Onboard USB

When enabled, you can connect USB devices to the onboard USB port on the rear of the computer. The default setting is Enabled.

## Reset PnP Resources

The system resources are already properly configured. If resource conflicts arise, you can set this parameter to Yes to reset and reallocate PnP resources, after which the BIOS automatically resets this parameter to No, which is the default setting.

## Power Saving Options

Selecting Power Saving Options on the BIOS Utility main screen presents a screen that allows you to adjust several power-saving settings.

## When Lid is Closed

The computer's lid switch acts as its power switch: opening the display wakes up the computer, closing the display puts it to sleep. The When Lid is Closed setting determines which suspend mode the computer enters when the display is closed: Suspend to Disk or Suspend to Memory. The default is Suspend to Disk.

- ❑ **Suspend to Disk.** With this setting, the computer saves all data to the hard disk when you close the display. The computer wakes up when you reopen the display.

# System Utilities

- ❑ **Suspend to Memory.** With this setting, the computer saves all data to memory when you close the display or press the suspend hot key Fn+Esc (**Z**). The computer wakes up when you reopen the display or press any key.



---

**Note:** If an external monitor is connected to the computer, the computer will not enter suspend mode if you close the display. To enter suspend mode, disconnect the external monitor, open and reclose the display.

---



---

**Important!** Sleep Manager automatically creates a suspend-to-disk file when it is run. If the file becomes invalid, suspend-to-disk mode becomes unavailable, and the computer automatically switches to suspend-to-memory mode.

---

## Suspend to Disk on Critical Battery

With this parameter is set to Enabled, the computer enters suspend-to-disk mode when the battery becomes critically low. The default setting is Enabled.

## Display Always On

This parameter lets you specify whether the display is always on or not. When enabled, the screen will not blank. To save power, the default setting is Disabled.

## Resume On Modem Rings

You can set the computer to resume from suspend-to-memory mode upon detection of a specific number of modem rings, ranging from 1 to 7. Enabling this option overrides the suspend-to-disk function.



---

**Note:** This function is currently unavailable.

---

## Resume On Schedule

When this parameter is set to Enabled, the computer resumes from suspend-to-memory mode at the specified date and time. Enabling this option overrides the suspend-to-disk function.

The Resume Date and Resume Time parameters let you set the date and time for the resume operation. The date and time fields take the same format as the System Date and Time parameters in the System Configuration screen.

If you set a date and time prior to when the computer enters suspend mode, this field is automatically disabled. A successful resume occurring from a date and time match also automatically disables this field.

# System Utilities

## System Security

When you select System Security from the BIOS Utility main screen, a screen appears that allows you to set security options.



---

**Important!** If a password is currently present, the system prompts you to input the password before entering the System Security screen.

---

## Supervisor and User Passwords

The supervisor and user passwords both prevent unauthorized access to the computer. When these passwords are present, the computer prompts for the user or supervisor password during system boot-up and resume from suspend. The supervisor password also gives full access to the BIOS setup utility. The user password give limited access.



---

**Important!** The supervisor password must be set prior to setting the user password. If you enter the setup utility with the user password, you cannot modify the supervisor password or certain BIOS settings.

---

To set a password, follow these steps:

1. Select the desired password (Supervisor or User) to set or edit, and press → or ←. A special password prompt resembling a key appears:

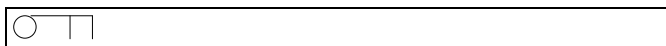

2. Enter a password of up to eight characters. (The characters do not appear on the screen as you type them.) After typing your password, press Enter. The same password prompt reappears:

3. Retype your password and press Enter to verify your first entry.

After you set a password, the computer sets the Supervisor Password (or User Password) parameter to Present. The next time you boot up, resume from suspend mode, run the BIOS setup utility, or unlock system resources, the password prompt appears and you must type the supervisor or user password to continue.



---

**Important!** The system continues to ask for your password until you enter the correct password. If you forget your password, contact your dealer for assistance.

---

To remove a password, select the password you want to remove and press ← or →.

## Diskette Drive Access Control (DOS mode only)

This parameter allows you to control the read and write functions of the floppy drive. The available options are: Normal, Write Protect All Sectors, Write Protect Boot Sector, and Disabled. The default is Normal.

# System Utilities

With this parameter set to Normal, the floppy drive functions normally. When the parameter is set to Write Protect All Sectors, all write functions to the floppy drive are disabled, but you can still read from a disk in the floppy drive. When the parameter is set to Write Protect Boot Sector, all write functions to the boot sector of the disk in the floppy drive are disabled. When the parameter is set to Disabled, the floppy drive is disabled.

## **Hard Disk Drive Access Control (DOS mode only)**

This parameter allows you to control the read and write functions of the hard drive. The available options are: Normal, Write Protect All Sectors, Write Protect Boot Sector and Disabled. The default is Normal.

With this parameter set to Normal, the hard drive functions normally. When the parameter is set to Write Protect All Sectors, all write functions to the hard drive are disabled. When the parameter is set to Write Protect Boot Sector, all write functions to the boot sector of the hard drive are disabled. When the parameter is set to Disabled, the hard drive is disabled.

## **Start Up Sequences**

This parameter determines which drive the system boots from when you turn on the system. The following table describes the available settings.

# System Utilities

Setting	Description
A: then C: (default)	System boots from the diskette in floppy drive A. If the diskette is missing or a non-system diskette, the system boots from hard disk C.
C: then A:	System boots from hard disk C. If the hard disk is a non-system disk, the system boots from floppy drive A.
A:	System boots from the diskette in floppy drive A. If the diskette is missing or a non-system disk, an error message appears.
C:	System boots from hard disk C. If the hard disk is a non-system disk, an error message appears.
CD-ROM then C: then A:	System boots from a CD if one is installed in the CD-ROM drive. If no CD is present, the system boots from the hard disk C. If the hard disk is a non-system disk, then the system boots from floppy drive A.

## Refresh New BIOS



**Warning! Contact your dealer to upgrade your BIOS.**

## Reset To Default Settings

When you select the Reset To Default Settings from the BIOS Utility main screen, a dialog box appears asking you to confirm that you want to reset all settings to their factory defaults.

## Troubleshooting

This section tells how to deal with common system problems. Read it before calling a technician if a problem occurs. Solutions to more serious problems require opening up the system. Do not attempt to open the system by yourself. Contact your dealer or an TravelMate authorized service center for assistance.

---

**Question****Answer**

---

*I travel a lot and occasionally use my computer in extreme temperature conditions. Will the weather affect my computer?*

The computer's design uses materials that dissipate heat quickly, without the need of a fan that can be noisy at times. The unique power management system also ensures that major components do not run too hot by closely monitoring thermal conditions within the unit itself.

So, whether you are using the computer in the desert or in the arctic, you never need to worry about components breaking down or reduced performance. If you feel the unit is a bit warm, use the keyboard's automatic tilt feature to let the unit breathe a little.



## Question

## Answer

*What do I do if my computer hangs and rebooting doesn't solve the problem?*

Every machine should have a fail-safe switch as a last resort, even a computer. Desktops have a reset button and the computer has one too. It not only resets the machine, but it also re-synchronizes the computer and its devices for a successful restart.

The computer's reset switch is located inside a small pinhole on the computer's right panel. It can be activated with a pin, paper clip or the tip of a ballpoint pen. (Do not use a pencil as the pencil lead can break off and lodge itself in the pinhole.)

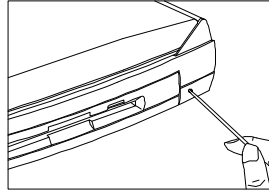

*I prefer using an external keyboard and mouse, but both have PS/2 connectors and there is only one PS/2 port on the computer. How do I connect them to the computer at the same time?*

To connect two PS/2-type devices to the computer, use a PS/2 Y-bridge cable, as described on page 76. (Connecting two PS/2-type devices via the mini dock is not a problem, because there are separate PS/2 connectors for an external keyboard and mouse.)

# Appendix

---

**Question****Answer**

---

*I want to use an external mouse but I want to disable the internal touchpad.*

First you need to enable the external mouse (see page 71). Then do the following:

1. In the Windows 95 Control Panel, open the mouse dialog.
  2. Click on the General tab and change the mouse device to fit your external mouse (e.g., standard serial mouse if you connect an external serial mouse).
-

## Question

## Answer

*I opened the display but the computer does not start or boot-up.*

Look at the power indicator (⏻) on the display panel.

If the indicator is not lit, no power is being applied to the computer. Check the following:

- ❑ If you are running on battery power, it may be low and unable to power the computer. Connect the AC adapter to recharge the battery pack.
- ❑ Make sure the AC adapter is plugged in properly to the computer and to the power outlet.

If the indicator is lit, check the following:

- ❑ Is a non-bootable (non-system) diskette in the floppy drive? Remove it and press Ctrl+Alt+Del to restart the system.
- ❑ The operating system files may be damaged or missing. Insert the Recovery CD in the CD-ROM drive and press Ctrl+Alt+Del to restart the system. See the Recovery CD Kit for details.



## Question

## Answer

---

*The serial mouse does not work.*

Do the following:

- Make sure the serial mouse drivers are installed. Use the Add New Hardware tool for assistance.
- Make sure that the serial cable is plugged securely into the serial port.
- Press Fn+F3 to reconfigure Plug-and-Play devices.

---

*The printer does not work.*

Do the following:

- Make sure that the printer is turned on and is connected to a power outlet.
- Make sure the printer cable is connected securely to the computer's parallel port and to the corresponding port on the printer.
- Press Fn+F3 to reconfigure Plug-and-Play devices.
- Press Fn+F2 to enter the BIOS setup utility. Select About My Computer, press Enter, and then press PgDn to go to page 2. Check if the Parallel Port is enabled. If it is disabled, go to page 3 of the Advanced System Configuration (see page 103) and set the parallel port parameters as described on page 105.

# Appendix

## Question

## Answer

*No sound comes out of the computer speakers.*

Check the following:

- The speakers may be muted. Press Fn+F6. If the pop-up does not contain a speaker icon, press Fn+F7 to turn on the speakers.
- The volume level may be too low. Press Fn+Ctrl+↑ to increase the volume.
- If headphones or external speakers are connected to the line-out port on the computer's left panel, the internal speakers are automatically turned off.
- Onboard audio may be disabled. Press Fn+F2 to enter the BIOS setup utility. Select About My Computer, press Enter, and then press PgDn to go to page 2. If onboard audio is disabled, go to page 3 of the Advanced System Configuration (see page 103) and change the onboard audio setting to Enabled.

## Startup Error Messages

If you receive an error message during system startup, note the message and take corrective action. The following table lists the error messages in alphabetical order together with the recommended course of action.

<b>Error Message</b>	<b>Corrective Action</b>
Disk Boot Failure	Insert a system disk in drive A, then press Enter.
Diskette Drive Type Mismatch	Press Fn+F2 to reconfigure the computer with the BIOS setup utility.
Equipment Configuration Error	Press Fn+F2 to reconfigure the computer with the BIOS setup utility.
Insert system diskette and press <Enter> key to reboot	Insert a system disk in drive A, then press Enter.
Memory Size Mismatch	Press Fn+F2 and select the System Configuration menu. Then press Esc to exit the BIOS setup utility, saving the current settings.
Missing Operating System	Correct the hard drive type and reboot. See the specification label pasted on the back side of the computer or attached to hard disk drive. We suggest you set the hard drive type to Auto.
Non-system disk or disk error. Replace and strike any key when ready	Insert a system disk in drive A, then press Enter.

# Appendix

Error Message	Corrective Action
Real-Time Clock Error	Press Fn+F2 to reconfigure the computer with the BIOS setup utility.



**Caution:** When you reconfigure the computer with the BIOS setup utility, you must restart the system for the changes to take effect. To restart the system during startup, press Ctrl+Alt+Del before Windows 95 begins loading. To restart from Windows 95, click the Start button, and select Shutdown, Restart the Computer.

If you still encounter problems after going through the corrective measures, or if other error messages appear during startup, contact your dealer or an authorized service center for assistance.



## Specifications

Item	Standard	Optional
Microprocessor	Intel Pentium® processor with MMX™ technology	
Memory System/Main	32MB Dual 64-bit memory banks	Expandable to 128MB using 8/16/32/64MB soDIMMs
External cache	512KB L2 cache (synchronous SRAM)	
Flash BIOS	256KB	
Storage system	One 2.5-inch, high-capacity Enhanced-IDE hard disk  One high-speed IDE CD-ROM drive module  One 3.5-inch, 1.44MB floppy drive module (internal/external use)	Higher-capacity E-IDE hard disk  Second 3-inch hard disk module (swaps into the module bay)
Display	Active-matrix TFT LCD  12.1-inch, 800x600, 64K colors (SVGA) 13.3-inch, 1024x768, 64K colors (XGA)	Up to 1024x768, 64K-color ultra-VGA monitor  LCD projection panel

# Appendix

Item	Standard	Optional
Video system	PCI local bus video with 128-bit graphics accelerator	
Audio system	16-bit stereo audio with built-in FM synthesizer  Built-in microphone and dual angled speakers	
Communications system		PC card modem
Operating system	Windows 95	
Keyboard and pointing device	84-/85-key with Win95 keys  Touchpad (centrally-located on palm rest)	101-/102-key, PS/2-compatible keyboard or 17-key numeric keypad  External serial or PS/2 mouse or similar pointing device

# Appendix

Item	Standard	Optional
I/O ports	One 9-pin RS-232 serial port (UART16550-compatible)	Serial mouse, printer or other serial devices
	One 25-pin parallel port (EPP/ECP-compliant)	Parallel printer or other parallel devices; floppy drive module (when used externally)

# Appendix

Item	Standard	Optional
I/O ports (continued)	One 15-pin CRT port	Up to a 1024x768 ultra-VGA monitor
	One 6-pin PS/2 connector	17-key numeric keypad, PS/2 keyboard, mouse or trackball
	One 240-pin mini dock connector	Mini dock
	One type III or two type II PC Card slot(s)	LAN card or other PC cards
	One fast infrared port (IrDA-compliant)	External IR adapter
	One 3.5mm mini-jack microphone-in/line-in port	Microphone or line-in device
	One 3.5mm mini-jack speaker-out/line-out port	Speakers or headphones
	One USB port	USB device
Weight with FDD with CD-ROM	(includes battery) 7.4 lbs. (3.4kg) 7.5 lbs. (3.5kg)	
Dimensions Round contour Main footprint	L x W x H 11.7 x 9.1 x 2 inches (297 x 230 x 51 mm)	Carrying bag

# Appendix

Item	Standard	Optional
Temperature		
Operating	50° to 95°F (10° to 35°C)	
Non-operating	14° to 140°F (-10° to 60°C)	
Humidity	(non-condensing)	
Operating	20% to 80% RH	
Non-operating	20% to 80% RH	
AC adapter	100 to 240Vac, 50 to 60Hz autosensing AC adapter	Extra AC adapter
Battery pack		Extra battery pack
Type	57WH Lithium-Ion battery with intelligent charging and built-in battery gauge	
Charge time	2-hour rapid-charge 4-hour in-use charge	

# Appendix

## System Memory Map

Address Range	Definition	Function
000000 - 09FFFF	640 KB memory	Base memory
0A0000 - 0BFFFF	128 KB video RAM	Reserved for graphics display buffer
0C0000 - 0CBFFF	Video BIOS	Video BIOS
CC000 - CDFFF CE000 - CFFFF	System CardBus MiniDock CardBus	
0F0000 - 0FFFFF	64 KB system BIOS	System BIOS
10000 - 7FFFF 80000 - 27FFF	Extended memory	Onboard memory SIMM memory
FE0000 - FFFFFFF	256 KB system ROM	Duplicate of code assignment at 0E0000-0FFFFFF

## I/O Address Map

Address Range	Device
000 - 00F	DMA controller-1
020 - 021	Interrupt controller-1
02E - 02F	NS87338 peripheral controller
040 - 043	Timer 1
048 - 04B	Timer 2
060 - 06E	Keyboard controller chip select
070 - 071	Real-time clock and NMI mask
080 - 08F	DMA page register
0A0 - 0A1	Interrupt controller-2
0C0 - 0DF	DMA controller-2

Address Range	Device
1F0 - 1F7	Hard disk select
3F6 - 3F7	Hard disk select
170 - 177	CD-ROM select
376 - 377	CD-ROM select
220 - 22F	Audio
240 - 24F	Audio - default
260 - 26F	Audio
280 - 28F	Audio
278 - 27F	Parallel port 3
2E8 - 2EF	COM 4
2F8 - 2FF	COM 2 - IrDA
300 - 301	MPU-401 port - default
310 - 311	MPU-401 port
320 - 321	MPU-401 port
330 - 321	MPU-401 port
378 - 37F	Parallel port 2
388 - 38B	FM synthesizer
3BC - 3BE	Parallel port 1
3B4, 3B5, 3BA	Video subsystem
3C0 - 3C5	
3C6 - 3C9	Video DAC
3C0 - 3CF	Enhanced graphics display
3D0 - 3DF	Color graphics adapter
3E8 - 3EF	COM3
3F0 - 3F7	Floppy disk controller
3F8 - 3FF	COM 1 - Serial 1
CF8 - CFF	PCI configuration register

# Appendix

## Interrupts

Interrupt	Source Device
IRQ 0	System Timer
IRQ 1	Keyboard
IRQ 2	Cascade
IRQ 3	IrDA / 2F8h
IRQ 4	Serial Port 1 / 3F8h
IRQ 5	Audio
IRQ 6	Floppy Disk Controller (FDC)
IRQ 7	Parallel Port
IRQ 8	Real Time Clock (RTC)
IRQ 9	USB/System CardBus
IRQ 10	Reserved for PCMCIA card
IRQ 11	Reserved for PCMCIA card/MiniDock CardBus
IRQ 12	PS/2 Mouse
IRQ 13	Co-processor
IRQ 14	Hard disk
IRQ 15	CD-ROM

## DMA Channels

Controller	Channel	Address	Function
1	0	0087	Audio(default)/IrDA(option)
1	1	0083	Audio(default)/ECP(option) IrDA(option)
1	2	0081	Diskette
1	3	0082	Audio(option)/FIR IrDA(default) /ECP(default)
2	4	Cascade	Cascade
2	5	008B	
2	6	0089	Spare
2	7	008A	



## IMPORTANT SAFETY INSTRUCTIONS

- 1.** Read these instructions carefully. Save these instructions for future reference.
- 2.** Follow all warnings and instructions marked on the product.
- 3.** Unplug this product from the wall outlet before cleaning. Do not use liquid cleaners or aerosol cleaners. Use a damp cloth for cleaning.
- 4.** Do not use this product near water.
- 5.** Do not place this product on an unstable cart, stand, or table. The product may fall, causing serious damage to the product.
- 6.** Slots and openings in the cabinet and the back or bottom are provided for ventilation; to ensure reliable operation of the product and to protect it from overheating, these openings must not be blocked or covered. The openings should never be blocked by placing the product on a bed, sofa, rug, or other similar surface. This product should never be placed near or over a radiator or heat register, or in a built-in installation unless proper ventilation is provided.
- 7.** This product should be operated from the type of power indicated on the marking label. If you are not sure of the type of power available, consult your dealer or local power company.
- 8.** Do not allow anything to rest on the power cord. Do not locate this product where persons will walk on the cord.
- 9.** If an extension cord is used with this product, make sure that the total ampere rating of the equipment plugged into the extension cord does not exceed the extension cord ampere rating. Also, make sure that the total rating of all products plugged into the wall outlet does not exceed the fuse rating.

# Appendix

- 10.** Never push objects of any kind into this product through cabinet slots as they may touch dangerous voltage points or short out parts that could result in a fire or electric shock. Never spill liquid of any kind on the product.
- 11.** Do not attempt to service this product yourself, as opening or removing covers may expose you to dangerous voltage points or other risks. Refer all servicing to qualified service personnel.
- 12.** Unplug this product from the wall outlet and refer servicing to qualified service personnel under the following conditions:
  - a. When the power cord or plug is damaged or frayed
  - b. If liquid has been spilled into the product
  - c. If the product has been exposed to rain or water
  - d. If the product does not operate normally when the operating instructions are followed. Adjust only those controls that are covered by the operating instructions since improper adjustment of other controls may result in damage and will often require extensive work by a qualified technician to restore the product to normal condition.
  - e. If the product has been dropped or the cabinet has been damaged
  - f. If the product exhibits a distinct change in performance, indicating a need for service
  - g. Replace battery with the same type as the product's battery we recommend. Use of another battery may present a risk of fire or explosion. Refer battery replacement to a qualified serviceman.
- 13.** Warning! Battery may explode if not handled properly. Do not recharge, disassemble or dispose of in fire. Keep away from children and dispose of used battery promptly.

- 14.** Use only the proper type of power supply cord set (provided in your accessories box) for this unit. It should be a detachable type: UL listed/CSA certified, type SPT-2, rated 7A 125V minimum, VDE approved or its equivalent. Maximum length is 15 feet (4.6 meters).

## Canadian DOC Notice

This digital apparatus does not exceed Class B limits for radio noise emissions from digital apparatus set out in the Radio Interference Regulations of the Canadian Department of Communications.

Le présent appareil numérique n'émet pas de bruits radioélectriques dépassant les limites applicables aux appareils numériques de la classe B prescrites dans le règlement sur le brouillage radioélectrique édicté par le Ministère des Communications du Canada.

## FCC Class B Radio Frequency Interference Statement

This equipment has been tested and found to comply with the limits for a Class B digital device, pursuant to Part 15 of FCC Rules. These limits are designed to provide reasonable protection against harmful interference in a residential installation. This equipment generates, uses, and can radiate radio frequency energy and, if not installed and used in accordance with the instructions, may cause harmful interference to radio communications. However, there is no guarantee that interference will not occur in a particular installation. If this equipment does cause harmful interference to radio or television reception, which can be determined by turning the equipment off and on, the user is encouraged to try to correct the interference by one or more of the following measures:

1. Reorient or relocate the receiving antenna.
2. Increase the separation between the equipment and receiver.
3. Connect the equipment into an outlet on a circuit different from that to which the receiver is connected.
4. Consult the dealer or an experienced radio/television technician for help.

### Notice 1:

The changes or modifications not expressly approved by the party responsible for compliance could void the user's authority to operate the equipment.

### Notice 2:

Shielded interface cables, if any, must be used in order to comply with the emission limits.

## A

about my computer, 87  
AC adapter, 3  
addresses. *See* base addresses;  
    memory addresses  
advanced PIO mode, 95  
advanced power management, 51  
audio, 33–35, 59  
    hot keys, 35  
automatic tilt, 27

## B

balance, 23, 35  
base addresses  
    I/O map, 116  
    memory map, 116  
    parallel port, 96  
    serial infrared port, 96  
    serial port, 95  
battery gauge, 22  
battery indicator, 15, 45, 48  
battery pack, 4, 42–50  
    charge in use, 45  
    charging, 44  
    checking, 45  
    gauge, 47  
    installing, 5, 43  
    low-battery warning, 48  
    optimizing life, 47  
    rapid charge, 45  
    removing, 43  
    storage, 48  
    trickle charge, 45  
BIOS setup utility, 86  
    about my computer, 87  
    enhanced IDE features, 94  
    external cache, 94  
    internal cache, 94  
    onboard communication ports,  
        95  
    power saving options, 97

    reset to default settings, 103  
    system configuration, 89–97  
    system security, 99–103  
brightness, 23, 107

## C

cable  
    file transfer, 68  
    floppy drive, 66  
    PS/2 Y-bridge, 67  
cache, 94  
Caps Lock, 17, 18  
CD-ROM, 30  
    eject, 23, 24, 31  
    swapping, 33  
charge in use, 45  
cleaning, 3  
compression, 81  
configuration. *See* BIOS setup  
    utility  
contrast, 23, 107  
CRT. *See* display; monitor, external  
cursor-control keys, 19

## D

date, 90  
DC-in port, 37  
disk boot failure, 110  
disk compression, 81  
diskette drive  
    access control, 101  
diskette drive type mismatch, 110  
diskettes, 7  
    startup, 6  
display, 14, 107  
    brightness, 23, 107  
    contrast, 23, 107  
    opening and closing, 14  
    power-on, 14  
    toggle, 22

# Index

---

display always on, 98  
DMA channel, 118  
dock. *See* mini dock

## E

eject  
    CD, 23, 24, 31  
    menu, 22, 24  
embedded keypad, 19, 91  
equipment configuration error, 110  
error messages  
    Sleep Manager, 82  
    startup, 110  
external  
    floppy drive, 31  
    keyboard, 61  
    keypad, 62  
    monitor, 60  
    mouse, 63  
external cache, 94

## F

fast boot, 92  
features, 11  
file transfer cable, 68  
FIR port. *See* infrared port  
FlashStart, 14  
floppy drive, 30, 31, 66  
    cable, 66  
    external, 31  
    swapping, 33  
Fn, 17, 35  
fuel gauge, 22, 23, 45, 47, 49

## H

hard disk, 30, 73  
    32-bit access, 95  
    access control, 102  
    installing, 73

    size > 504MB, 94  
headphones, 40, 59, 109  
heuristic power management, 52  
hot keys, 35

## I

I/O address map, 116  
indicator lights  
    battery, 15  
    power, 15  
indicators  
    battery, 45, 48  
    power, 106  
infrared port, 38. *See* infrared port  
    base address, 96  
insert system diskette, 110  
internal cache, 94  
internal speaker, 92  
Internet, 10  
interrupts, 118  
    parallel, 96  
    serial infrared port, 96  
    serial port, 95  
IRQ. *See* interrupts

## K

keyboard, 17  
    automatic tilt, 27  
    embedded keypad, 19  
    external, 61  
    keypad, 91  
    lock keys, 17  
    palm rest, 29  
    touchpad, 24–27  
keypad  
    embedded, 19, 91  
    external, 62  
keys  
    Caps Lock, 17, 18  
    cursor-control, 19

Fn, 17, 35  
lock, 17  
NumLk, 17, 18  
ScrLk, 17, 18  
Windows 95, 20

## L

LCD expansion mode, 92  
lights. *See* indicator lights  
line-in port, 40, 59  
line-out port, 40, 59  
lock keys, 17  
lock system resources, 22

## M

memory, 70  
    installing, 71  
memory map, 116  
memory size mismatch, 110  
mic-in port, 40  
microphone, 34, 40, 59  
mini dock, 24, 65  
missing operating system, 110  
module bay, 30  
modules  
    swapping, 33  
monitor, external, 60  
mouse, 108  
    external, 63  
multimedia ports, 40  
multiple sector read/write, 95

## N

non-system disk, 110  
not enough space for allocation, 80  
Num lock after boot, 91  
NumLk, 17, 18

## O

onboard communication ports, 95  
onboard USB, 97

# Index

---

## P

palm rest, 29  
parallel port, 37  
    base address, 96  
passwords, 22, 41, 100  
PC cards, 56–58  
    slots, 39  
PCMCIA cards. *See* PC cards  
peripherals, 36  
plug and play, 21, 97  
pointing device. *See* mouse  
ports, 35–40  
POST error messages. *See* error  
    messages, startup  
power indicator, 15, 106  
power management, 50–55  
    advanced (APM), 51  
    heuristic (HPM), 52  
printers, 56, 108  
PS/2 port, 37  
PS/2 Y-bridge cable, 67

## R

rapid charge, 45  
real-time clock error, 111  
reset, 105  
reset to default settings, 103  
resume on modem ring, 99  
resume on schedule, 99

## S

safety instructions, 119  
screen. *See* display  
screen blackout, 22  
ScrLk, 17, 18  
security, 41, 99–103  
serial port, 37  
    base address, 95  
setup. *See* BIOS setup utility

silent boot, 92  
Sleep Manager, 53, 76–84  
    accessing, 77  
    creating reserved space, 78  
    exiting, 82  
    minimizing, 82  
    not enough space for allocation,  
        80  
    removing reserved space, 81  
    troubleshooting, 82  
    uninstalling, 84  
sound. *See* audio  
speaker-out port, 40  
speakers, 22, 34, 40, 59, 109  
    balance, 23, 35  
    volume, 22, 35  
specifications, 111–15  
startup sequences, 102  
storage, 29–33  
    CD-ROM, 30  
    floppy drive, 30, 31  
    hard disk, 30  
suspend to disk, 24, 53, 76, 97  
suspend to disk on critical battery,  
    98  
suspend to memory, 21, 54, 98  
system configuration, 89–97  
system resource lock, 41

## T

technical support, 10  
temperature, 2, 43, 48, 104  
tilt, 27  
time, 90  
touchpad, 24–27  
    configuring, 85  
travel, 8  
trickle charge, 45  
troubleshooting, 104–9  
    Sleep Manager, 82  
turbo mode, 23



## U

Universal Serial Bus port, 37  
upgrades  
    hard disk, 73  
    memory, 70  
USB, 64  
USB port. *See* Universal Serial Bus  
    port

## V

volume, 22, 35

## W

*weather*, 104  
web site, 10  
when lid is closed, 15, 53, 97  
Windows 95 keys, 20

## Y

Y-bridge cable, 67

## Z

zero-volt suspend. *See* Sleep  
    Manager; suspend to disk