

TravelMate 6592/6592G

Service Guide

Service guide files and updates are available on the ACER/CSD web; for more information, please refer to <http://csd.acer.com.tw>

PRINTED IN TAIWAN

Revision History

Please refer to the table below for the updates made on TravelMate 6592/6592G service guide.

Date	Chapter	Updates

Copyright

Copyright © 2007 by Acer Incorporated. All rights reserved. No part of this publication may be reproduced, transmitted, transcribed, stored in a retrieval system, or translated into any language or computer language, in any form or by any means, electronic, mechanical, magnetic, optical, chemical, manual or otherwise, without the prior written permission of Acer Incorporated.

Disclaimer

The information in this guide is subject to change without notice.

Acer Incorporated makes no representations or warranties, either expressed or implied, with respect to the contents hereof and specifically disclaims any warranties of merchantability or fitness for any particular purpose. Any Acer Incorporated software described in this manual is sold or licensed "as is". Should the programs prove defective following their purchase, the buyer (and not Acer Incorporated, its distributor, or its dealer) assumes the entire cost of all necessary servicing, repair, and any incidental or consequential damages resulting from any defect in the software.

Acer is a registered trademark of Acer Corporation.

Intel is a registered trademark of Intel Corporation.

Pentium and Pentium II/III are trademarks of Intel Corporation.

Other brand and product names are trademarks and/or registered trademarks of their respective holders.

Conventions

The following conventions are used in this manual:

SCREEN MESSAGES	Denotes actual messages that appear on screen.
NOTE	Gives bits and pieces of additional information related to the current topic.
WARNING	Alerts you to any damage that might result from doing or not doing specific actions.
CAUTION	Gives precautionary measures to avoid possible hardware or software problems.
IMPORTANT	Reminds you to do specific actions relevant to the accomplishment of procedures.

Preface

Before using this information and the product it supports, please read the following general information.

1. This Service Guide provides you with all technical information relating to the BASIC CONFIGURATION decided for Acer's "global" product offering. To better fit local market requirements and enhance product competitiveness, your regional office MAY have decided to extend the functionality of a machine (e.g. add-on card, modem, or extra memory capability). These LOCALIZED FEATURES will NOT be covered in this generic service guide. In such cases, please contact your regional offices or the responsible personnel/channel to provide you with further technical details.
2. Please note WHEN ORDERING FRU PARTS, that you should check the most up-to-date information available on your regional web or channel. If, for whatever reason, a part number change is made, it will not be noted in the printed Service Guide. For ACER-AUTHORIZED SERVICE PROVIDERS, your Acer office may have a DIFFERENT part number code to those given in the FRU list of this printed Service Guide. You MUST use the list provided by your regional Acer office to order FRU parts for repair and service of customer machines.

Table of Contents

Chapter 1 System Specifications 1

Features	1
System Block Diagram	4
Mainboard Layout	5
Top View	5
Bottom View	6
Your Acer Notebook Tour	7
Front View	7
Closed Front View	8
Left View	9
Right View	9
Rear view	10
Base view	11
Indicators	12
Easy-Launch Buttons	13
Touchpad Basics	14
Using the Keyboard	15
Lock Keys and embedded numeric keypad	15
Windows Keys	15
Hot Keys	16
Special Key	17
Acer Empowering Technology	19
Acer eDataSecurity Management	19
Acer eLock Management	21
Acer ePerformance Management	22
Acer eRecovery Management	23
Acer eSettings Management	24
Acer ePower Management	25
Acer OrbiCam	28
Using the System Utilities	33
Acer GridVista (dual-display compatible)	33
Launch Manager	34
Hardware Specifications and Configurations	35

Chapter 2 System Utilities 43

BIOS Setup Utility	43
Navigating the BIOS Utility	44
Information	45
Main	46
Advanced	48
Security	49
Boot	54
Exit	55
BIOS Flash Utility	56

Chapter 3 Machine Disassembly and Replacement 57

General Information	58
Before You Begin	58
Disassembly Procedure Flowcharts	59
Main Unit Disassembly Flowchart	59
LCM Module Disassembly Flowchart	60
Main Unit Disassembly Procedure	61

Removing the Battery Pack	61
Removing the Cover Securing Screws and Covers	61
Removing the HDD	62
Removing the Memory Module	63
Removing the Wireless Card	64
Removing the ODD	65
Removing Dummy Trays	65
Removing the Switch Cover	66
Removing the Keyboard	67
Disconnecting the TouchPad	69
Removing the Switch Board	70
Removing the Modem Module	70
Removing the Antenna Cables	71
Removing the LCM Module	72
Removing the TouchPad	72
Removing the Mainboard	73
Removing the I/O Board	74
Removing the Heatsink and Fan Module	75
Removing the CPU	76
LCM Module Disassembly Procedure	77
Removing the LCM Bezel	77
Removing the LCD Panel	78
LCM Module Reassembly Procedure	81
Replacing the LCD Panel	81
Replacing the LCM Bezel	83
Main Module Reassembly Procedure	84
Replacing the CPU	84
Replacing the Heatsink and Fan Module	84
Replacing the I/O Board	85
Replacing the Mainboard	86
Replacing the TouchPad	87
Replacing the LCM Module	87
Replacing the Antenna Cables	88
Replacing the Modem	88
Replacing the Switch Board	89
Reconnecting the TouchPad	89
Replacing the Keyboard	90
Replacing the Switch Cover	91
Replacing the Dummy Trays	92
Replacing the ODD	92
Replacing the Wireless Card	93
Replacing the Memory Module	94
Replacing the HDD	94
Replacing the Covers	94
Replacing the Battery Pack	96

Chapter 4 Troubleshooting 97

System Check Procedures	98
External Diskette Drive Check	98
External CD-ROM Drive Check	98
Keyboard or Auxiliary Input Device Check	98
Memory check	99
Power System Check	99
Touchpad Check	101
Power-On Self-Test (POST) Error Message	102

Index of Error Messages	103
Phoenix BIOS Beep Codes	106
Index of Symptom-to-FRU Error Message	110
Intermittent Problems	113
Undetermined Problems	114
Chapter 5 Jumper and Connector Locations	115
Top View	115
Bottom View	116
Connector Descriptions	117
Chapter 6 FRU (Field Replaceable Unit) List	119
TravelMate 6592 Exploded Diagram	120

System Specifications

Features

Below is a brief summary of the computer's many features:

Operating system

- q Genuine Windows® Vista™ Capable
- q Genuine Windows® XP Home Edition (Service Pack 2)
- q Genuine Windows® XP Media Center Edition 2005 (Rollup 2)

NOTE: Windows® Vista™ Capable PCs come with Windows® XP installed, and can be upgraded to Windows® Vista™. For more information on Windows® Vista™ and how to upgrade, go to: Microsoft.com/windowsvista.

Platform and memory

- q Mobile Intel Core 2 Duo Mobile Processor — Micro-FCPBA 478-pin
- q Intel PM965 / Intel GM965 (North Bridge) — FCBGA 1299 balls
- q Intel ICH8ME (South Bridge) — mBGA 676 balls
- q Integrated Intel® PRO/Wireless 3945ABG network connection (dual-band tri-mode 802.11a/b/g) Wi-Fi CERTIFIED™ solution, supporting Acer SignalUp™ wireless technology
- q Core logic: Intel® 910GML+ICH6M
- q Up to 2GB of DDR2 400 MHz memory, upgradeable to 4GB using two soDIMM modules (dual-channel support)

Display and graphics

- q 20.1" WSXGA+ high-brightness Acer CrystalBrite™ TFT LCD, 1680 x 1050 pixel resolution, 6 lamps
- q 19" WXGA+ high-brightness Acer CrystalBrite™ TFT LCD, 1440 x 900 pixel resolution, 4 lamps
- q 16 ms typical on/off and 8 ms average gray-to-gray response time
- q Simultaneous multi-window viewing via Acer Vista™ supported
- q NVIDIA® GeForce® Go 7600 with up to 512MB TurboCache™ (256 MB of dedicated GDDR2 VRAM and up to 256 MB of shared system memory) or,
- q NVIDIA® GeForce® Go 7300 with up to 256MB TurboCache™ (128 MB of dedicated GDDR2 VRAM and up to 128 MB of shared system memory)
- q Supporting NVIDIA® PureVideo™ technology (WMV HD, High-Definition MPEG-2 Hardware Acceleration, integrated HDTV encoder) dual-link DVI, Microsoft® DirectX® 9.0, Shader Model 3.0, OpenEXR High Dynamic Range (HDR) technology, NVIDIA® PowerMizer™ 6.0 and PCI Express®
- q Dual independent display
- q 16.7 million colors (20.1" LCD model)
- q 16.2 million colors (19" LCD model)
- q MPEG-2/DVD hardware-assisted capability
- q S-video/TV-out (NTSC/PAL) support
- q DVI-D (true digital video interface) with HDCP (High-bandwidth Digital Content Protection) support

-
- q Acer Arcade™ featuring Acer CinemaVision™ and Acer ClearVision technologies

TV-tuner

- q Acer TV-tuner options:
 - Analog TV-tuner supporting hardware MPEG-2 stream encoding
 - Digital and analog hybrid TV-tuner supporting hardware MPEG-2 stream encoding
 - Digital and analog hybrid TV-tuner supporting software MPEG-2 stream encoding
- q Analog TV-tuner supporting international analog TV standards (NTSC/PAL/SECAM)
- q Digital TV-tuner supporting DVB-T (Digital Video Broadcasting Terrestrial) standard (6 MHz to 8MHz)
- q TV-tuner I/O:
 - RF jack for digital/analog TV antenna cable input
 - AV-in port for composite/S-video/line-in audio/video input
- q TV-tuner cables:
 - PAL cable for digital/analog TV input, PAL/SECAM to NTSC port converter
 - Mini DIN cable: RCA jack and S-video port for audio/video input
- q Acer DVB-T antenna (UHF/VHF reception) supporting Acer SignalUp™ wireless technology

Audio

- q Audio system with two built-in Acer 3DSonic (1.5W) stereo speakers and one Acer BasSonic Subwoofer
- q Dolby® Digital Live and DTS Neo: PC support
- q Intel® High Definition audio support
- q S/PDIF (Sony/Philips Digital Interface) support for digital speakers (1.5W)
- q Sound Blaster Pro™ and MS Sound compatible
- q Two built-in stereo microphone

Storage subsystem

- q One or two 80/100/120 GB Serial ATA hard disk drive, supporting software RAID 0/1
- q Optical drive options: DVD-Super Multilayer double-layer drive (slot-load)
- q 5-in-1 card reader, supporting Secure Digital (SD), MultiMediaCard (MMC), Memory Stick® (MS), Memory Stick PRO™ (MS PRO), xD-Picture Card™ (xD)

Input devices

- q 88/89-key Acer FineTouch™ keyboard with 5-degree curve
- q Touchpad with 4-way scroll button
- q Four easy-launch buttons
- q Two front-access switches: WLAN LED and Bluetooth® LED-switches (for selected models)

Communication

- q Acer Video Conference, featuring Voice and Video over Internet Protocol (VVoIP) support via Acer OrbiCam™ and optional Acer Bluetooth® VoIP phone
- q Acer OrbiCam™ 1.3 megapixel CMOS camera, featuring:
 - 30 degree ergonomic rotation
 - Acer VisageOn™ technology
 - Acer Primalite™ technology

-
- q Modem: 56K ITU V.92 modem with PTT approval; wake-on ring ready
 - q LAN: gigabit Ethernet; wake-on-LAN ready
 - q WPAN: Bluetooth® 1.1 @ 723 bps
 - q Optional WLAN: ICH6-M (dual-band tri-mode 802.11a/b/g) Wi-Fi® CERTIFIED™ solution, supporting Acer SignalUp™ wireless technology

I/O Ports

- q CRT port --- Support CRT monitor.
- q 3 * USB 2.0/1.1 ports
- q Head Phone port
- q MIC-In
- q Line-In
- q RJ11/RJ45
- q DC Jack
- q IR
- q CardBus slot
- q Smart Card slot
- q 5-in-1 media card port
- q 1394 port
- q PS/2
- q Serial port
- q DVI (only for Discrete sku)
- q Docking port

Environment

- q Temperature:
 - operating: 5°C to 35°C
 - Non-operating: -20°C to 65°C
- q Humidity (non-condensing):
 - operating: 20%~80%
 - Non-operating: 20%~80%

System Block Diagram

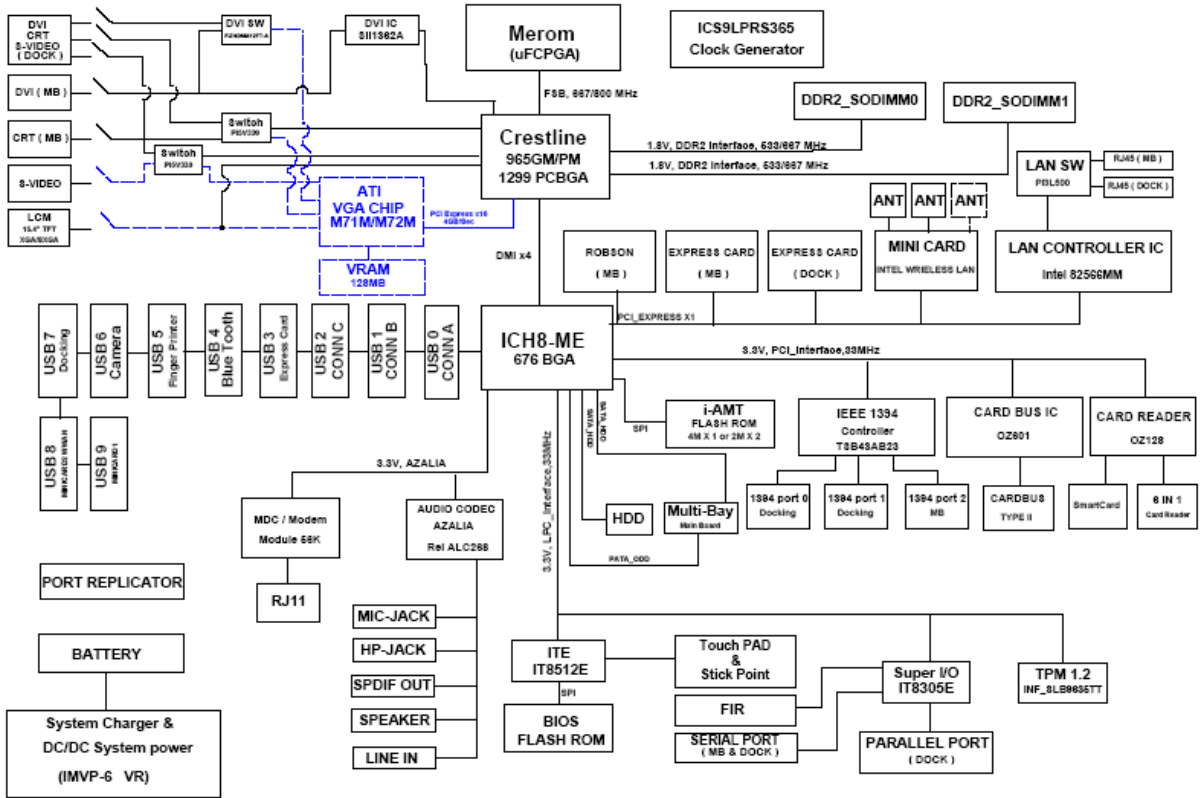

Mainboard Layout

Top View

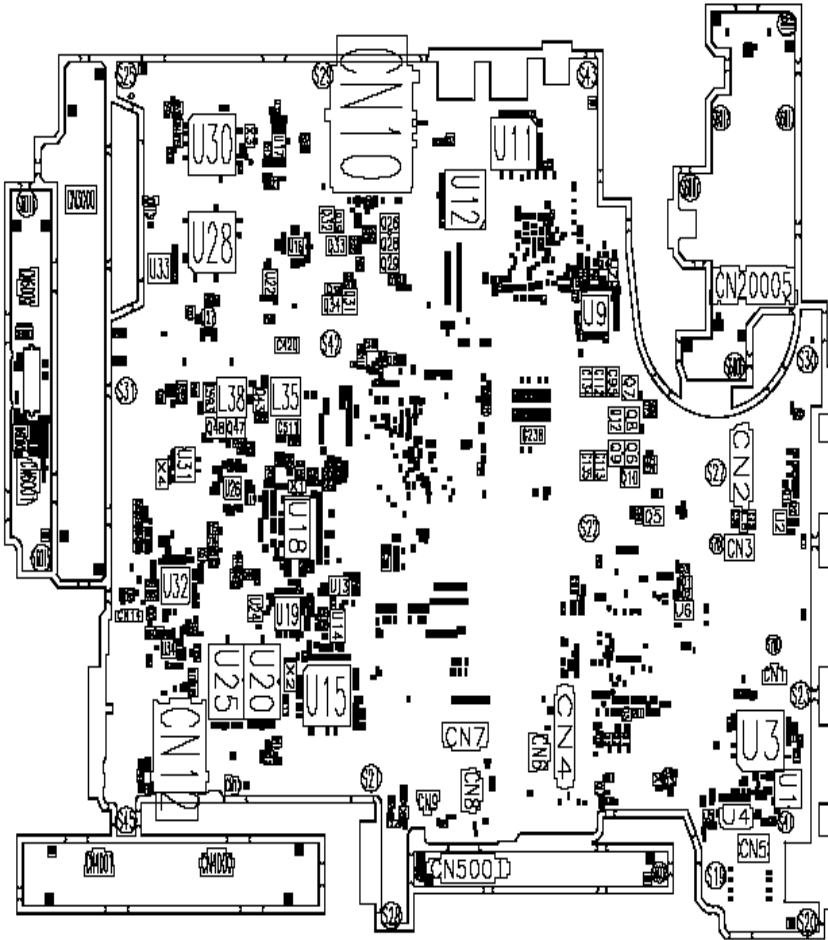

1	JACK1	AV-in Jack	20	CN29	PATA HDD Connector
2	CN1	TV Antenna Connector	21	CN30	SATA HDD Connector
3	CN2	S-Video Connector	22	U23	North Bridge
4	CN509	Card Bus Socket	23	U33	RAID Controller
5	CN3	S-Video Connector	24	U37	Timing Controller
6	CN4	HDMI Connector	25	CN13	CPU Socket
7	U6	Video Memory	26	CN28	SATA HDD Connector
8	CN5	I/O Board to Main Board Connector	27	CN24	BIOS Flash Memory
9	U7	Video Memory	28	U515	Audio Codec
10	CN8	DVI-D Port	29	CN20	Mini PCI Socket
11	U14	Graphic Controller	30	CN23	Mini Card Connector
12	U9	DDR2 SDRAM IC	31	CN26	Media Board Connector
13	U15	DDR2 SDRAM IC	32	CN22	Wireless LAN Card Connector
14	JACK2	Microphone Jack	33	CN21	USB Connector
15	U11	Ethernet Controller	34	CN19	USB Connector
16	CN15	DIMM Socket	35	CN16	USB Connector

17	CN14	DIMM Socket	36	CN11	IEEE port
18	CN18	Optical Disk Drive Connector	37	U25	PCI cardbus/Media Board/1394 IC
19	U39	South Bridge			

Bottom View

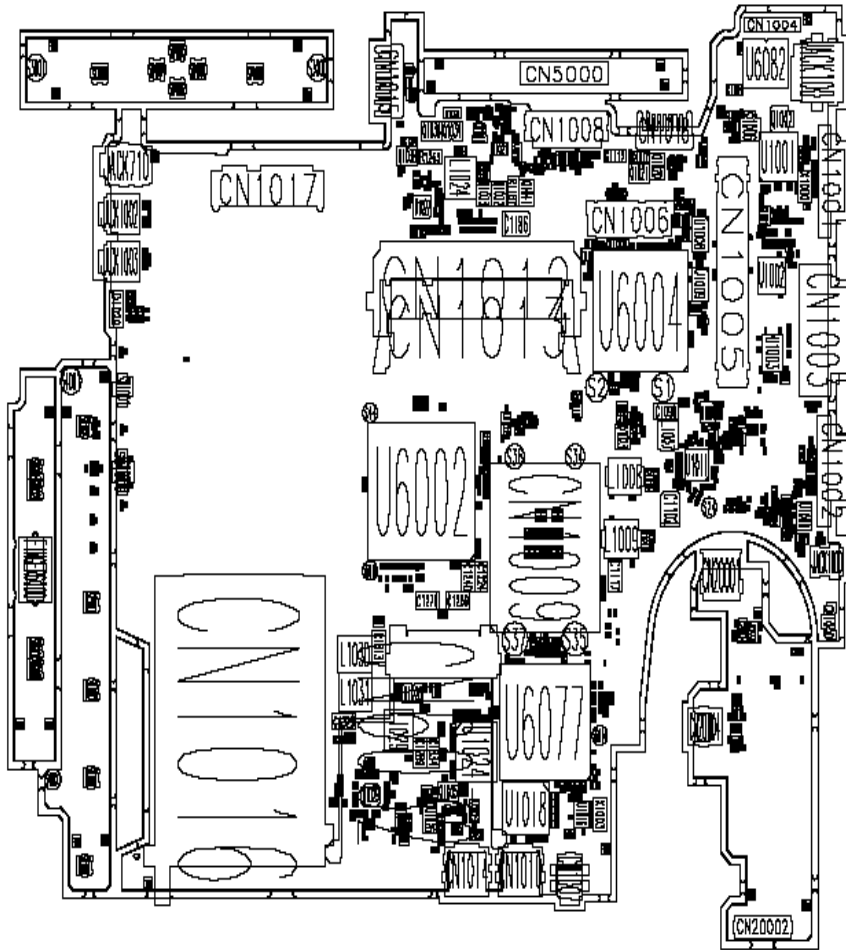

1	U504	LAN Transformer GSN 5009	9	CN4000	Touchpad Connector (Touchpad to main board)
2	CN502	Launch Board Connector	10	CN4001	6-pin Touchpad Board Connector
3	U503	Video Memory	11	CN504	Audio Board Connector
4	U502	Video Memory	12	CN506	DDR2 SDRAM IC
5	CN4002	LCD Connector	13	CN5001	Hotkey Board Connector
6	CN3000	Hotkey Board Connector	14	CN5000	Main Board to Media Board Connector
7	CN503	Express Card Slot	15	CN505	Touchpad Board Connector
8	CN507	DDR2 SDRAM IC			

Your Acer Notebook Tour

After knowing your computer features, let us show you around your new TravelMate 6592/6592G computer.

Front View









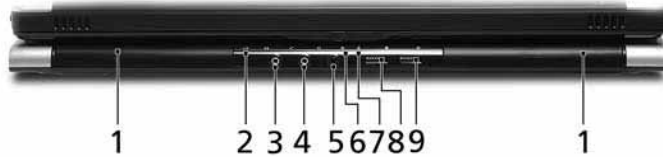

#	Icon	Item	Description
1		Built-in camera	1.3 megapixel web camera for video communication.
2		Display screen	Also called Liquid-Crystal Display (LCD), displays computer output.
3		Media/volume buttons	For use with Acer Arcade and other media playing programs.
4/8		Microphone	Internal microphone for sound recording.
5		Touchpad	Touch-sensitive pointing device which functions like a computer mouse.
6		Click buttons (left, center and right)	The left and right buttons function like the left and right mouse buttons; the center button serves as a 4-way scroll button.
7		Palmrest	Comfortable support area for your hands when you use the computer.
9		Keyboard	For entering data into your computer.

10/11		Easy-launch buttons	Buttons for launching frequently used programs.
12		Power button	Turns the computer on and off.



Closed Front View



#	Icon	Item	Description
1		Speaker	Left and right speakers deliver stereo audio output.
2		Infrared port/CIR receiver	Interfaces with infrared devices (e.g., infrared printer and IR-aware computer)/ Receives signals from a remote control.
3		Line-in jack	Accepts audio line-in devices (e.g., audio CD player, stereo walkman).
4		Microphone-in jack	Accepts input from external microphones.
5		Headphones/speaker/line-out jack with S/PDIF support	Connects to audio line-out devices (e.g., speakers, headphones).
6		Power indicator	Indicates the computer's power status.
7		Battery indicator	Indicates the computer's battery status.
8		Bluetooth [®] communication button/indicator	Enables/disables the Bluetooth [®] function. Indicates the status of Bluetooth communication.
9		Wireless communication button/indicator	Enables/disables the wireless function. Indicates the status of wireless LAN communication.

Left View







#	Icon	Item	Description
1		USB 2.0 ports	Connects to USB 2.0 devices (e.g., USB mouse, USB camera).
2		Modem (RJ-11) port	Connects to a phone line.
3		Optical drive	Internal optical drive; accepts CDs or DVDs (slot-load or tray-load depending on model).
4		Optical disk access indicator	Lights up when the optical drive is active.
5		Optical drive eject button	Ejects the optical disk from the drive.
6		Emergency eject hole	Ejects the optical drive tray when the computer is turned off.
7		Latch	Locks and releases the lid.

Right View











#	Icon	Item	Description
1		Latch	Locks and releases the lid.
2		5-in-1 card reader	Accepts Secure Digital (SD), MultiMediaCard (MMC), Memory Stick (MS), Memory Stick PRO (MS PRO), xD-Picture Card (xD).

3		3 USB 2.0 ports	Connect to USB 2.0 devices (e.g., USB mouse, USB camera).
4		4-pin IEEE 1394 port	Connects to IEEE 1394 devices.
5		PC Card slot eject button	Ejects the PC Card from the slot.
6		PC Card slot	Accepts one Type II PC Card.
7		Express Card/54 slot	Accepts and ExpressCard/34 module Note: ExpressCards are third generation of PC cards, hot-swappable and smaller than previous PC Cards. Designed for both desktop and mobile use, ExpressCards use either USB 2.0 or a single lane PCI Express technology that provides 500 Mbytes/sec total throughput. Formerly code named "NEWCARD," ExpressCards are 5 mm thick like Type II PC Cards, but do not use the same 86x54 mm footprint. ExpressCards come in 75x54 mm and 75x34 mm sizes. Express Card/54 slot means this notebook accepts 75x54mm ExpressCards.

Rear view



#	Icon	Item	Description
1		DC-in jack	Connects to an AC adapter.
2		TV-in port	Accepts input signals from analog/digital TV-tuner devices (for selected models).
3		AV-in port	Accepts input signals from audio/video (AV) devices (manufacturing option).
4		Kensington lock slot	Connects to a Kensington-compatible computer security lock.

#	Icon	Item	Description
5		Ventilation slots	Enable the computer to stay cool, even after prolonged use.
6		S-video/TV-out (NTSC/PAL) port	Connects to a television or display device with S-video input.
7		External display (VGA) port	Connects to a display device (e.g., external monitor, LCD projector).
8	DVI-D	DVI-D port	Supports digital video connections.
9		Ethernet (RJ-45)	Connects to an Ethernet 10/100/1000-based network (for selected models).
10		Parallel port	Connects to a printer.
11		Serial port	Connects to a serial device.

Base view



#	Item	Description
1	Ventilation slots and cooling fan	Enable the computer to stay cool, even after prolonged use. Note: Do not cover or obstruct the opening of the fan.





2	Memory compartment	Houses the computer's main memory.
3	Battery lock	Locks the battery in position.
4	Battery release latch	Releases the battery for removal.
5	Battery bay	Houses the computer's battery pack.
6	Hard disk bay	Houses the computer's hard disk (secured with screws)
7	Sub woofer	Emits low frequency sound output.



Indicators

The computer has several easy-to-read status indicators.



The front panel indicators are visible even when the computer cover is closed up.

Icon	Function	Description
	Standby	Indicates the computer's standby status.
	HDD	Indicates when the hard disc or optical drive is active.
	Cap lock	Lights when Cap Lock is activated
	Num lock	Lights when Num Lock is activated.
	Power	Lights up when the computer is on.

Icon	Function	Description
	Battery	Lights up when the battery is being charged.
	Bluetooth	Indicates the status of Bluetooth communication.
	Wireless LAN	Indicates the status of wireless LAN communication.

NOTE: 1. **Charging:** The light shows amber when the battery is charging. 2. **Fully charged:** The light shows green when in AC mode.

Easy-Launch Buttons

Located above the keyboard are four buttons. These buttons are called easy-launch buttons. They are: mail Web browser, Empowering Key “*e*” and one user-programmable button.

Press “*e*” to run the Acer Empowering Technology. The mail and Web browser buttons are pre-set to email and Internet programs, but can be reset by users. To set the Web browser, mail and programmable buttons, run the Acer Launch Manager.



Launch key	Default application
<i>e</i>	Acer Empowering Technology (user-programmable)
P	User-programmable
Web browser	Internet browser (user-programmable)
Mail	Email application (user-programmable)

Touchpad Basics

The following teaches you how to use the touchpad:

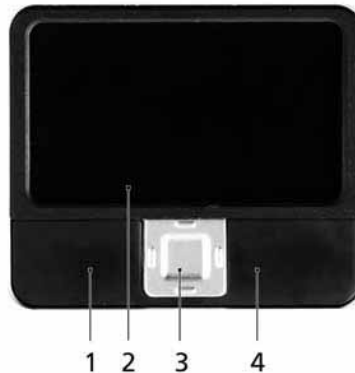

- q Move your finger across the touchpad (2) to move the cursor.
- q Press the left (1) and right (4) buttons located beneath the touchpad to perform selection and execution functions. These two buttons are similar to the left and right buttons on a mouse. Tapping on the touchpad is the same as clicking the left button.
- q Use the 4-way scroll (3) button to scroll up or down and move left or right a page. This button mimics your cursor pressing on the right scroll bar of Windows applications.

Function	Left Button (1)	Right Button (4)	Main touchpad (2)	Center button (3)
Execute	Click twice quickly		Tap twice (at the same speed as double-clicking the mouse button)	
Select	Click once		Tap once	
Drag	Click and hold, then use finger on the touchpad to drag the cursor.		Tap twice (at the same speed as double-clicking a mouse button); rest your finger on the touchpad on the second tap and drag the cursor.	
Access context menu		Click once		
Scroll				Click and hold to move up/down/left/right.

NOTE: When using the touchpad, keep it - and your fingers - dry and clean. The touchpad is sensitive to finger movements; hence, the lighter the touch, the better the response. Tapping too hard will not increase the touchpad's responsiveness.

Using the Keyboard

The keyboard has full-sized keys and an embedded keypad, separate cursor keys, two Windows keys and twelve function keys.

Lock Keys and embedded numeric keypad

The keyboard has three lock keys which you can toggle on and off.

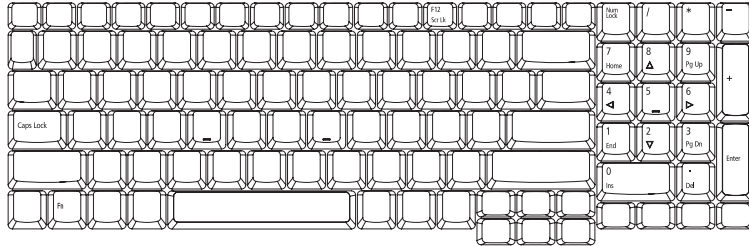









Lock Key	Description
Caps Lock	When Caps Lock is on, all alphabetic characters typed are in uppercase.
Num lock <Fn>+<F11>	When Num Lock is on, the embedded keypad is in numeric mode. The keys function as a calculator (complete with the arithmetic operators +, -, *, and /). Use this mode when you need to do a lot of numeric data entry. A better solution would be to connect an external keypad.
Scroll lock <Fn>+<F12>	When Scroll Lock is on, the screen moves one line up or down when you press the up or down arrow keys respectively. Scroll Lock does not work with some applications.

The embedded numeric keypad functions like a desktop numeric keypad. It is indicated by small characters located on the upper right corner of the keycaps. To simplify the keyboard legend, cursor-control key symbols are not printed on the keys.

Desired Access	Num Lock On	Num Lock Off
Number keys on embedded keypad	Type numbers in a normal manner.	
Cursor-control keys on embedded keypad	Hold <Shift> while using cursor-control keys.	Hold <Fn> while using cursor-control keys.
Main keyboard keys	Hold <Fn> while typing letters on embedded keypad.	Type the letters in a normal manner.

Windows Keys

The keyboard has two keys that perform Windows-specific functions.



Key	Icon	Description
Windows key 		<p>Pressed alone, this key has the same effect as clicking on the Windows Start button; it launches the Start menu. It can also be used with other keys to provide a variety of function:</p> <ul style="list-style-type: none">  + <Tab> Activates next taskbar button.  + <E> Opens the My Computer window  + <F1> Opens Help and Support.  + <F> Opens the Find: All Files dialog box.  + <R> Opens the Run dialog box.  + M Minimizes all windows. <p><Shift>+  + <M> Undoes the minimize all windows action.</p>
 Application key		This key has the same effect as clicking the right mouse button; it opens the application's context menu.





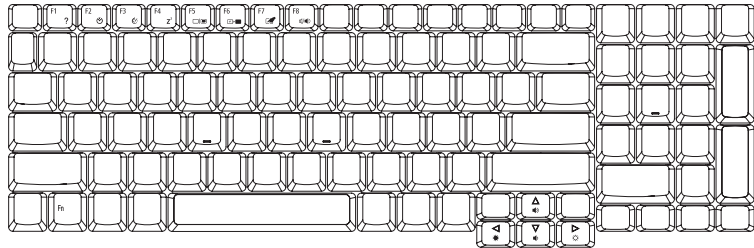



Hot Keys

The computer employs hotkeys or key combinations to access most of the computer's controls like screen brightness, volume output and the BIOS utility.

To activate hot keys, press and hold the <Fn> key before pressing the other key in the hotkey combination.



Hot Key	Icon	Function	Description
<Fn>+<F1>		Hot key help	Displays help on hot keys.
<Fn>+<F2>		Acer eSetting	Launches the Acer eSettings in Acer eManager.
<Fn>+<F3>		Acer ePowerManagement	Launches the Acer ePowerManagement in Acer Empowering Technology. See "Acer Empowering Technology" on page 19.

Hot Key	Icon	Function	Description
<Fn>+<F4>		Sleep	Puts the computer in Sleep mode.
<Fn>+<F5>		Display toggle	Switches display output between the display screen, external monitor (if connected) and both.
<Fn>+<F6>		Screen blank	Turns the display screen backlight off to save power. Press any key to return.
<Fn>+<F7>		Touchpad toggle	Turns the internal touchpad on and off.
<Fn>+<F8>		Speaker toggle	Turns the speakers on and off.
<Fn>+<w>		Volume up	Increases the speaker volume.
<Fn>+<y>		Volume down	Decreases the speaker volume.
<Fn>+<-x>		Brightness up	Increases the screen brightness.
<Fn>+<-z>		Brightness down	Decreases the screen brightness

Special Key

You can locate the Euro symbol and US dollar sign at the upper-center and/or bottom-right of your keyboard. To type:

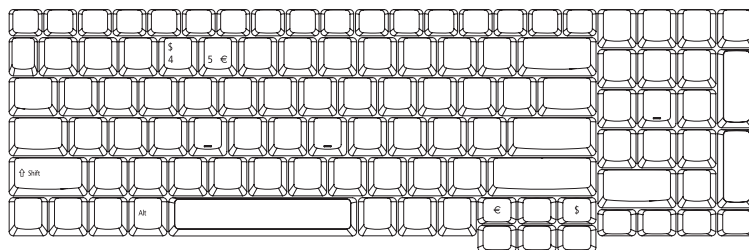

The Euro symbol

1. Open a text editor or word processor.

-
2. Either directly press the < € > symbol at the bottom-right of the keyboard, or hold <Alt Gr> and then press the <5> symbol at the upper-center of the keyboard.

NOTE: Some fonts and software do not support the Euro symbol. Please refer to www.microsoft.com/typography/faq/faq12.htm for more information.

The US dollar sign

1. Open a text editor or word processor.
2. Either directly press the < \$ > key at the bottom-right of the keyboard, or hold <Shift> and then press the <4> key at the upper-center of the keyboard.

NOTE: This function varies by the operating system version.

Acer Empowering Technology

Acer's innovative Empowering Technology makes it easy for you to access frequently used functions and manage your new Acer notebook. It features the following handy utilities:

- q **Acer eDataSecurity Management** protects data with passwords and advanced encryption algorithms.
- q **Acer eLock Management** limits access to external storage media.
- q **Acer ePerformance Management** improves system performance by optimizing disk space, memory and registry settings.
- q **Acer eRecovery Management** backs up/recovers data flexibly, reliably and completely.
- q **Acer eSettings Management** accesses system information and adjusts settings easily.
- q **Acer ePower Management** extends battery power via versatile usage profiles.
- q **Acer ePresentation Management** connects to a projector and adjusts display settings conveniently.



For more information, press the < *e* > key to launch the Empowering Technology menu, then click on the appropriate utility and select the Help function.

Acer eDataSecurity Management

Acer eDataSecurity Management is handy file encryption utility that protects your files from being accessed by unauthorized persons. It is conveniently integrated with Windows explorer as a shell extension for quick and

easy data encryption/decryption and also supports on-the-fly file encryption for MSN Messenger and Microsoft Outlook.

There are two passwords that can be used to encrypt/decrypt a file; the supervisor password and the file-specific password. The supervisor password is a “master” password that can decrypt any file on your system; the file-specific password will be used to encrypt files by default, or you can choose to enter your own file-specific password when encrypting a file.

NOTE: The password used to encrypt a file is the unique key that the system needs to decrypt it. If you lose the password, the supervisor password is the only other key capable of decrypting the file. If you lose both passwords, there will be no way to decrypt your encrypted file! **Be sure to safeguard all related passwords!**





Acer eLock Management

Acer eLock Management is a security utility that allows you to lock up your removable data, optical and floppy drives to ensure that data can't be stolen while your notebook is unattended.

- q Removable data devices - includes USB disk drives, USB pen drives, USB flash drives, USB MP3 drives, USB memory card readers, IEEE 1394 disk drives and any other removable disk drives that can be mounted as a file system when plugged into the system.
- q Optical drive devices - includes any kind of CD-ROM or DVD-ROM drives.
- q Floppy disk drives - 3.5-inch disks only.

To activate Acer eLock Management, a password must be set first. Once set, you may apply lock to any of the three kinds of devices. Lock(s) will immediately be set without any reboot necessary, and will remain locked after rebooting, until unlocked.

If you do not set a password, Acer eLock Management will reset back to the initial status with all locks removed.

NOTE: If you lose your password, there is no method to reset it except by reformatting your notebook or taking your notebook to an Acer Customer Service Center. Be sure to remember or write down your password.



Acer ePerformance Management

Acer ePerformance Management is a system optimization tool that boosts the performance of your Acer notebook. It provides you with the following options to enhance overall system performance:

- q Memory optimization - releases unused memory and check usage.
- q Disk optimization - removes unneeded items and files.
- q Speed optimization - improves the usability and performance of your Windows XP system.



Acer eRecovery Management

Acer eRecovery Management is a powerful utility that does away with the need for recovery disks provided by the manufacturer. The Acer eRecovery Management utility occupies space in a hidden partition on your system's HDD. User-created backups are stored on D:\ drive. Acer eRecovery Management provides you with:

- q Password protection.
- q Recovery of applications and drivers.
- q Image/data backup:
 - q Back up to HDD (set recovery point).
 - q Back up to CD/DVD.
- q Image/data recovery tools:
 - q Recover from a hidden partition (factory defaults).
 - q Recover from the HDD (most recent user-defined recovery point).
 - q Recover from CD/DVD.



NOTE: If your computer did not come with a Recovery CD or System CD, please use Acer eRecovery Management's "System backup to optical disk" feature to burn a backup image to CD or DVD. To ensure the best results when recovering your system using a CD or Acer eRecovery Management, detach all peripherals (except the external Acer ODD, if your computer has one), including your Acer ezDock.

Acer eSettings Management

Acer eSettings Management allows you to inspect hardware specifications and to monitor the system health status. Furthermore, Acer eSettings Management enables you to optimize your Windows operating system, so your computer runs faster, smoother and better.

Acer eSettings Management also:

- q Provides a simple graphical user interface for navigating through the program effortlessly.
- q Displays general system status and advanced monitoring for power users.
- q Logs when a hardware component has been removed or replaced.
- q Permits you to migrate personal settings.
- q Keeps a history log of all alerts that were previously issued.



Acer ePower Management

Acer ePower Management features a straightforward user interface. To launch it, select Acer ePower Management from the Empowering Technology interface, or double-click the Acer ePower Management icon in the task tray.

Acer Mode

The default setting is "Maximum Performance." You can adjust CPU speed, LCD brightness and other settings, or click on buttons to turn the following functions on/off: Wireless LAN, Bluetooth, CardBus, Memory Card, Audio, and Wired LAN.

DC Mode

To suit your usage, there are four pre-defined profiles - Entertainment, Presentation, Word Processing, and Maximum Battery. Or, you can define up to three of your own profiles.

Create new power scheme

1. Assign a name for the new scheme.
2. Choose existing scheme to use as a template.
3. Select whether used for mains (AC) or battery mode.
4. Choose which power options best fit your needs, then click OK.
5. The new profile will appear on the main screen.

Battery status

For real-time battery life estimates based on current usage, refer to the panel on the lower left-hand side of the window.

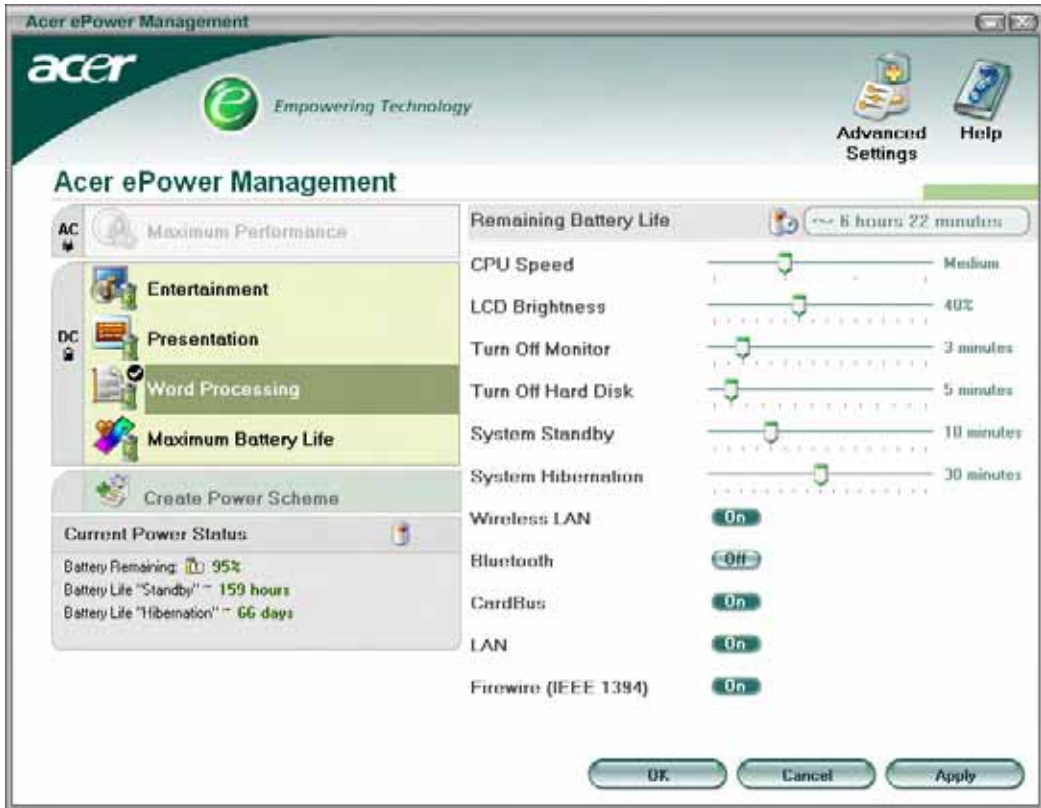

You can also click “Advanced Settings” to:

- q Set alarms.
- q Re-load factory defaults.
- q Select what actions will be taken when the cover is closed, and set passwords for accessing the system after Hibernation or Standby.
- q View information about Acer ePower Management.

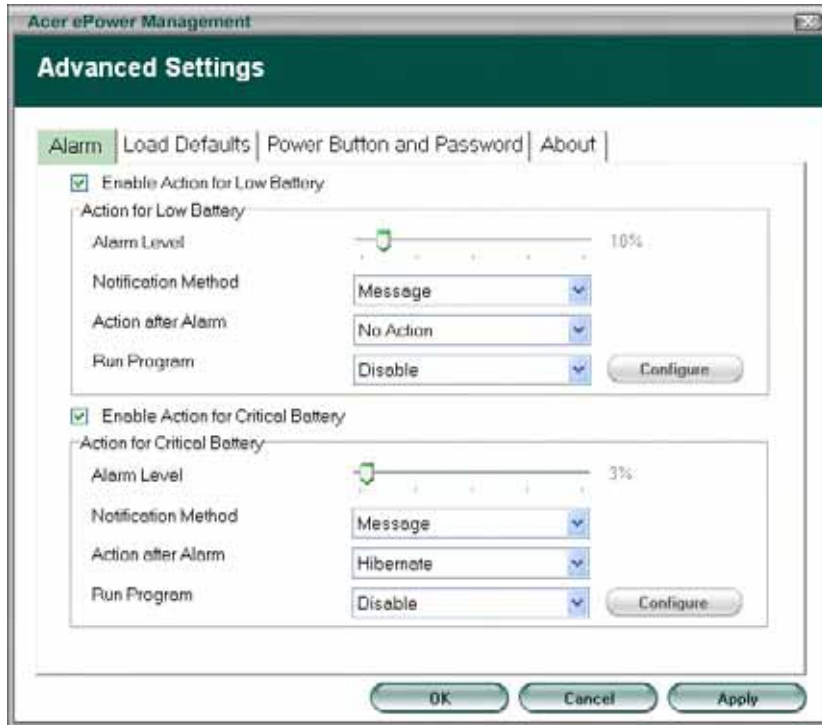

Acer ePresentation Management

Acer ePresentation Management lets you select from two of the most common projector resolutions: XGA and SVGA.



Acer OrbiCam

The Acer OrbiCam is a 1.3 megapixel CMOS camera appropriately mounted on the top of the LCD panel. The camera's 225-degree ergonomic rotation allows you to capture high-resolution photos or videos up front or at the back of the LCD panel. The Acer OrbiCam fully supports the Acer Video Conference technology so that you can transmit the best video quality over an instant Messenger service.

Getting to know your Acer OrbiCam

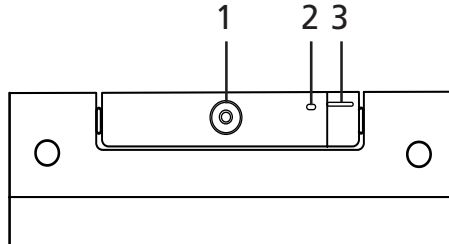

No.	Item
1	Lens
2	Power indicator
3	Rubber grip (selected models only)

Rotating the Acer Orbicam

The Acer OrbiCam rotates 225 degrees counterclockwise to achieve the desired angle. Refer to the illustrations below:

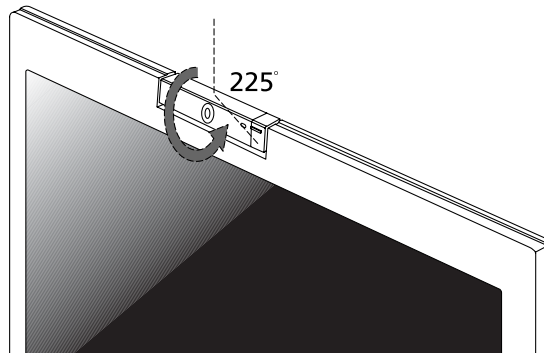

For your convenience, the camera snaps 45 degrees to match the position of your face in front or at the back of the LCD panel.

NOTE: Do not rotate the camera clockwise to prevent damage to the device.

Launching the Acer OrbiCam

To launch the Acer OrbiCam, double click on the Acer OrbiCam icon on the screen.

OR

Click Start > All programs > Acer > Acer OrbiCam. The Acer OrbiCam capture windows window appears.

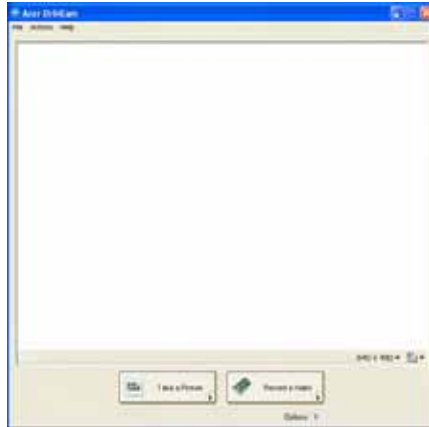

Changing the Acer OrbiCam settings

Resolution

To change the capture resolution, click the displayed resolution at the bottom right corner of the capture window, then select the desired resolution.

Options

Click Options to display the Window, Preview, and Folder tabs. Use the options to change the capture window size, preview settings, and the folder for captured photos or videos.



Camera Settings

- q Basic settings: Click the Camera Settings icon on the bottom right corner of the capture display, then select Camera Settings from the pop-up menu. You can adjust the Video, Audio, and Zoom/Face tracking options from this window.



- q Capture settings: From the Camera Settings window, click the Driver Settings button. The Properties window will appear.



- q Device Settings allows you to change the camera brightness, contrast, hue, saturation, sharpness, etc.
- q Advanced Settings allows you to achieve gain control, implement image mirror, select image enhancements and anti-flicker settings, and turn on/off the camera indicator.
- q Zoom/Face Track Settings allows you to adjust the zoom level and turn the face tracking feature on or off.

Capturing photos or videos

To capture a photo or a video clip, rotate the Acer OrbiCam to get the desired angle, then click the Take a Picture or Record a Video button. The Windows Picture and Fax Viewer or the Windows Media Player automatically launches to display or play a preview of the photo/video clip.

NOTE: By default, all photos and videos are saved in the My Pictures and My Videos folder.

Using the Acer OrbiCam as webcam

The Acer OrbiCam is automatically selected as the capture device of any instant messenger (IM) application. To use the Acer OrbiCam as a webcam, open the IM service, then select the video/webcam feature. You can now broadcast from your location to an IM partner anywhere in the world.

Enabling the Acer VisageON

The Acer VisageON technology comes with two features: Face tracking and Video effects (selected models only). The Face Tracking feature tracks your head movement and automatically centers your face in the capture window. The video effects feature allows you to select and apply an effect to your video transmissions.

NOTE: The face tracking feature is not capable of centering your face beyond the capture window frame. Minimal head movements are tracked more efficiently.

To enable the Acer VisageON:

1. Right click on this icon, then select VisageON from the pop-up menu.

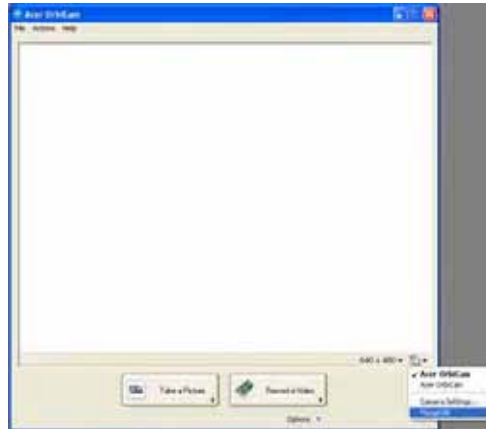

The VisageON window appears as below:



2. Select and apply a video effect in the left section of the VisageON window. Change the face tracking settings and options in the right section.

Using the face tracking feature

To use the face tracking feature:

1. Click the left icon down arrow button, then select Single User or Multiple Users from the pop-up menu. For multiple users, the face tracking feature automatically centers all the users' face in the capture window, otherwise the utility centers the face of the user closest to the camera.

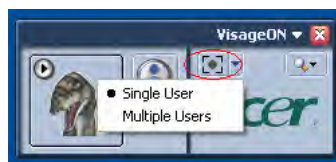

2. Click the right icon to zoom in/out or reset the current view.



3. Click VisageON to display a menu that allows to change the configuration of the camera, face tracking and video effects settings.

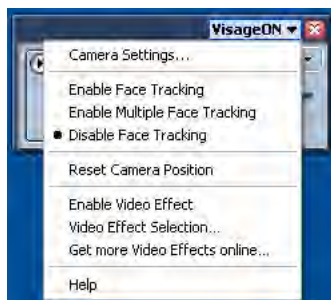

Using video effects (selected models only)

The Video Settings section allows you to select an avatar or accessory video effect from the list. To select an effect:

1. Click the encircled icon to display the available video effects. The Video Effect Selection window appears as below:



2. Click on a video effect to use. The selected effect appears in the video effects section of the VisageON window.



NOTE: When using avatars, you may have to calibrate the face points to achieve better tracking. Follow screen instructions in the VisageON to continue.

NOTE: You may use video effects when using the camera for IM chat/video sessions or call conferences.

Using the System Utilities

NOTE: The system utilities work under Microsoft Windows XP only.

Acer GridVista (dual-display compatible)

NOTE: This feature is only available on certain models.

To enable the dual monitor feature of the notebook, first ensure that the second monitor is connected, then select **Start, Control Panel, Display** and click on **Settings**. Select the secondary monitor (**2**) icon in the display box and then click the check box **Extend my windows desktop onto this monitor**. Finally, click **Apply** to confirm the new settings and click **OK** to complete the process.



Acer GridVista is a handy utility that offers four pre-defined display settings so you can view multiple windows on the same screen. To access this function, please go to **Start>All Programs** and click on **Acer GridVista**. You may choose any one of the four display settings indicated below:



Double (verticle), Triple (primary at left), Triple (primary at right), or Quad Acer Gridvista is dual-display compatible, allowing two displays to be partitioned independently.

Acer Gridvista is dual-display compatible, allowing two displays to be partitioned independently.

AcerGridVista is imple to set up:

1. Run Acer GridVista and select your preferred screen configuration for each display from the task bar.
2. Drag and drop each window into the appropriate grid.
3. Enjoy the convenience of a well-organized desktop.

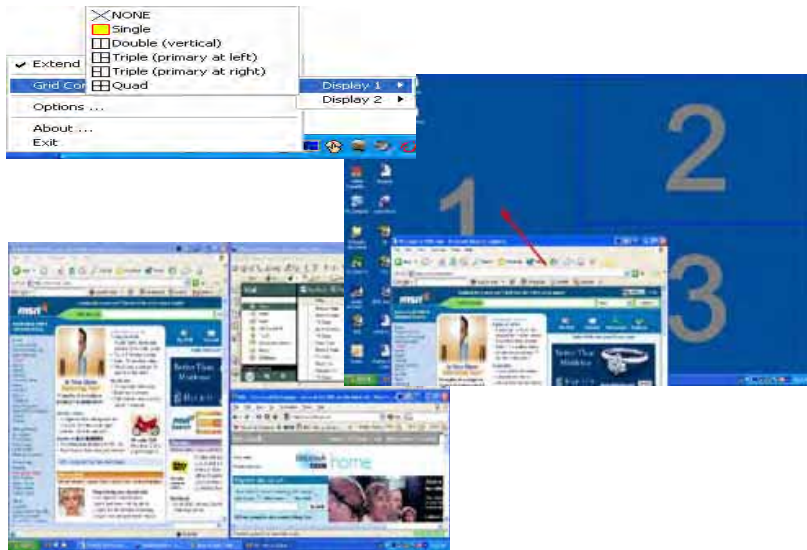

NOTE: Please ensure that the resolution setting of the second monitor is set to the manufacturer's recommended value.

Launch Manager

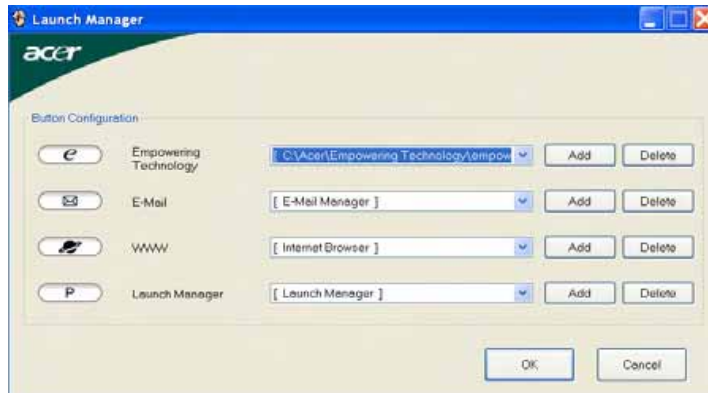

Launch Manager allows you to set the four easy-launch buttons located above the keyboard. You can access the Launch Manager by clicking on Start > All Programs > Launch Manager to start the application.

Hardware Specifications and Configurations

Processor

Item	Specification
CPU type	Intel® Pentium® M 725/730 Processor (2 MB L2 cache, 1.6GHz, 400/533 MHz FSB) Intel® Celeron M 370/380/390 Processor (1 MB L2 cache, 1.50/1.60/1.70GHz, 400MHz FSB)
Core logic	Intel® 910GML+ICH6M
CPU package	Intel socketable 478pin Micro-BGA
CPU core voltage	0.944~1.3V

CPU Fan True Value Table

TEST Condition: 35W@Ambient 35 degree C			
CPU Temperature		Fan Speed	Acoustic Level
Core 0	Core 1	(rpm)	(dBA)
86	86	3700	39
88	88	3450	36.5
91	91	3150	34.5
95	95	2800	31

BIOS

Item	Specification
BIOS vendor	Pheonix
BIOS Version	3A03
BIOS ROM type	PMC PM39LV040, 512KX8 CMOS Boot Block Flash Memory
BIOS ROM size	512KB Flash BIOS
BIOS package	32-pin PLCC
Supported protocols	ACPI 1.0b, PC Card 95, SM BIOS 2.3, IEEE1284-ECP/EPP, PCI 2.2, PnP 1.0a, DMI 2.0, PS/2 keyboard and mouse, USB 2.0, VGA BIOS, CD-ROM bootable, IEEE 1394
BIOS password control	Set by setup manual

NOTE: If you need to check PXE version, press F2 to enter BIOS then enable boot from LAN function. After that, power off the system and remove the HDD. Last, reboot the laptop. Then you will see PXE version displaying on the screen.

Second Level Cache

Item	Specification
Cache controller	Built-in CPU
Cache size	2MB for Intel® Pentium® M 725A Processor 1MB for Intel® Celeron M 360/370/380 Processor
1st level cache control	Always enabled
2st level cache control	Always enabled
Cache scheme control	Fixed in write-back

System Memory

Item	Specification
Memory controller	Built-in Intel® 910GML
Memory size	0MB (no on-board memory)
DIMM socket number	2 sockets
Supports memory size per socket	1024MB
Supports maximum memory size	2G (by two 1024MB SO-DIMM module)
Supports DIMM type	DDR 2 Synchronous DRAM
Supports DIMM Speed	400 MHz
Supports DIMM voltage	1.8V and 0.9V
Supports DIMM package	200-pin soDIMM
Memory module combinations	You can install memory modules in any combinations as long as they match the above specifications.

Memory Combinations

Slot 1	Slot 2	Total Memory
0MB	128MB	128MB
0MB	256MB	256MB
0MB	512MB	512MB
0MB	1024MB	1024MB
128MB	128MB	256MB
128MB	256MB	384MB
128MB	512MB	640MB
128MB	1024MB	1152MB
256MB	128MB	384MB
256MB	256MB	512MB
256MB	512MB	768MB
256MB	1024MB	1280MB
512MB	128MB	640MB
512MB	256MB	768MB
512MB	512MB	1024MB
512MB	1024MB	1536MB
1024MB	0MB	1024MB
1024MB	128MB	1152MB
1024MB	256MB	1280MB
1024MB	512MB	1536MB
1024MB	1024MB	2048MB

NOTE: Above table lists some system memory configurations. You may combine DIMMs with various capacities to form other combinations. On above table, the configuration of slot 1 and slot 2 could be reversed.

LAN Interface

Item	Specification
Chipset	Realtek 8110CL
Supports LAN protocol	10/100Mbps
LAN connector type	RJ45
LAN connector location	Right side

LAN Interface

Item	Specification
Features	Integrated 10/100 BASE-T transceiver Wake on LAN support compliant with ACPI 2.0 PCI v2.2

Modem Interface

Item	Specification
Data modem data baud rate (bps)	56K
Supports modem protocol	V.92
Modem connector type	RJ11
Modem connector location	Right side

Bluetooth Interface

Item	Specification
Chipset	Built-in ICH6-M
Data throughput	723 bps (full speed data rate)
Protocol	Bluetooth 1.1 (Upgradeable to Bluetooth 1.2 when SIG specification is ratified).
Interface	USB 1.1
Connector type	Mini-USB

Wireless Module 802.11b/g (optional device)

Item	Specification
Chipset	Built-in ICH6-M
Data throughput	11~54 Mbps
Protocol	802.11b+g
Interface	Mini-PCI type II

Hard Disk Drive Interface

Item			
Vendor & Model Name	Seagate 40G ST9402112A Toshiba MK4025GAS Hitachi HTS421240H9AT00 WD WD400UE-22HCT0 Samsung M40MP0402H	Seagate ST96812A Seagate ST960821A Toshiba MK6025GAS HGST HTS541260H9AT00 WD WD600UE-22HCT0	TOSHIBA MK8025GAS HITACHI HTS421280H9AT00 SEAGATE ST9808210A SEAGATE ST98823A TOSHIBA MK8026GAX HGST HTS541280H9AT00 WD WD800UE-22HCT0
Capacity (MB)	40000	60000	80000
Bytes per sector	512	512	512
Data heads	2	3 (for Hitachi and Seagate) 4 (for Toshiba)	4 (for Hitachi) 3 (for Seagate)
Drive Format			
Disks	1	2	2
Spindle speed (RPM)	4200 RPM	4200 RPM	4200 RPM
Performance Specifications			
Buffer size	2048KB	8192KB	8192KB

Hard Disk Drive Interface

Item			
Interface	ATA/ATAPI-6; ATA-6	ATA/ATAPI-6; ATA-6	ATA/ATA-6; ATA-6
Max. media transfer rate (disk-buffer, Mbytes/s)	372	350	350
Data transfer rate (host-buffer, Mbytes/s)	100 MB/Sec. Ultra DMA mode-5	100 MB/Sec. Ultra DMA mode-5	100 MB/Sec. Ultra DMA mode-5
DC Power Requirements			
Voltage tolerance	5V(DC) +/- 5%	5V(DC) +/- 5%	5V(DC) +/- 5%

Combo Drive Interface

Item	Specification	
Vendor & model name	DVD/CDRW HLDS GCC-4244N	
Performance Specification	With CD Diskette	With DVD Diskette
Transfer rate (KB/sec)	Sustained: Max 3.6Mbytes/sec	Sustained: Max 10.8Mbytes/sec
Buffer Memory	2MB	
Interface	Enhanced IDE(ATAPI) compatible	
Applicable disc format	DVD: DVD-ROM, (DVD-5, DVD-9, DVD-10, DVD-18),DVD-R (read, single border), DVD-RW, DVD-RAM (2.6GB, 4.7GB) CD: CD-DA, CD-ROM, CD-ROM XA, CD-R, CD-RW Photo (Multisession) Video CD, CD-Extra, (CD+), CD-test	
Loading mechanism	Load: Manual Release: (a) Electrical Release (Release Button) (b) Release by ATAPI command (c) Emergency Release	
Power Requirement		
Input Voltage	5 V +/- 5 % (Operating)	

DVD-Dual Interface

Item	Specification	
Vendor & model name	LITEON SOSW-833S PIONEER DVR-K16RA	
Performance Specification	With CD Diskette	With DVD Diskette
Transfer rate (KB/sec)	Sustained: Max 3.6Mbytes/sec	Sustained: Max 10.8Mbytes/sec
Buffer Memory	2MB	
Interface	Enhanced IDE(ATAPI) compatible	

DVD-Dual Interface

Item	Specification
Applicable disc format	Support disc formats 1. Reads data in each CD-ROM, CD-ROM XA, CD-1, Video CD, CD-Extra and CD-Text 2. Reads data in Photo CD (single and Multi-session) 3. Reads standard CD-DA 4. Reads and writes CD-R discs 5. Reads and writes CD-RW discs 6. Reads and writes in each dVD+R/RW (Ver. 1.1) 7. Reads data in each DVD-ROM and DVD-R (Ver. 2.0 for Authoring) 8. Reads and writes in each DVD-R (Ver. 2.0 for general), DVD-RW and DVD+R/RW (Ver1.1)
Loading mechanism	Load: Manual Release: (a) Electrical Release (Release Button) (b) Release by ATAPI command (c) Emergency Release
Power Requirement	
Input Voltage	5 V +/- 5 % (Operating)

Audio Interface

Item	Specification
Audio Controller	ALC655
Audio onboard or optional	Built-in
Mono or Stereo	Stereo
Resolution	16 bit stereo digital to analog converter 16 bit stereo analog to digital converter
Compatibility	AC97
Mixed sound source	Line-in, CD
Voice channel	8/16-bit, mono/stereo
Sampling rate	44,1 KHz (48K byte for AC97 interface)
Internal microphone	Yes
Internal speaker / Quantity	Yes/2

Video Interface

Item	Specification
Chipset	Built-in Intel® 910GML
Package	35.5 mm x 40 mm 1257 pin mBGA
Interface	internal PCIE
Supports ZV (Zoomed Video) port	Yes

Video Memory

Item	Specification
Chipset	Built-in Intel® 910GML
Memory size	64MB/128MB
Interface	DDR2

USB Port

Item	Specification
Chipset	Built-in ICH6-M
USB Compliancy Level	2.0
OHCI	USB 1.1 and USB 2.0 Host controller
Number of USB port	3
Location	Three on the right side
Serial port function control	Enable/Disable by BIOS Setup

PCMCIA Port

Item	Specification
PCMCIA controller	ENE CB1410
Supports card type	Type-II
Number of slots	One type-II
Access location	Left panel
Supports ZV (Zoomed Video) port	No ZV support
Supports 32 bit CardBus	Yes

System Board Major Chips

Item	Controller
Core logic	Intel® 910GML+ICH6-M
VGA	Built in Intel®910GML
LAN	RealTek 8110CL
USB 2.0	Built in ICH6-M
MODEM	Built-in ICH6-M
Bluetooth	Built-in ICH6-M
Wireless 802.11 b+g	Built-in ICH6-M
PCMCIA	ENE CB1410
Audio	Realtek ALC655

Keyboard

Item	Specification
Keyboard controller	ENE KB 3910
Total number of keypads	88-/89-key
Windows logo key	Yes
Internal & external keyboard work simultaneously	Plug USB keyboard to the USB port directly: Yes

Battery

Item	Specification
Vendor & model name	Sanyo (6cell) 2.0 Sony (6cell) 2.0 Panasonic (6cell) 2.0 Snayo (6cell) 2.4 Sony (6cell) 2.4 Panasonic (6cell)2.4 Sanyo (9cell) 2.4
Battery Type	Li-ion
Pack capacity	4000 mAH forSanyo (6cell) 2.0 3920 mAH Sony (6cell) 2.0 3900 mAH Panasonic (6cell) 2.0 4800 mAH Snayo (6cell) 2.4 4800 mAH Sony (6cell) 2.4 4800 mAH Panasonic (6cell)2.4 Sanyo (9cell) 2.4
Number of battery cell	6/9
Package configuration	3 cells in series, 2 series in parallel 3 cells in series, 3 series in parallel
Normal voltage	14.8V
Charge voltage	16.8+-0.2v

LCD 14.1 inch

Item	Specification			
Vendor & model name	AU B141EW01	CMO N14111-L02	QDI QD14TL01-03	SAMSUNG LTN141W1-L01
Screen Diagonal (mm)	14.1 inches	14.1 inches	14.1 inches	14.1 inches
Active Area (mm)	304.1x228.1	304.1x228.1	304.1x228.1	
Display resolution (pixels)	1024x768 XGA	1024x768 XGA	1024x768 XGA	
Pixel Pitch	0.297x0.297	0.099x0.297	0.297x0.297	
Pixel Arrangement	R.G.B. Vertical Stripe	R.G.B. Vertical Stripe	R.G.B. Vertical Stripe	
Display Mode	Normally White	Normally White	Normally White	
Typical White Luminance (cd/m ²) also called Brightness	180 (5 point average) 150 (5 point average)	160	150	
Luminance Uniformity	N/A	N/A	70	
Contrast Ratio	300	300	250	
Response Time (Optical Rise Time/Fall Time)msec	24/11 15/35	8/17	10/25	
Nominal Input Voltage VDD	+3.3V Typ.	+3.3V	3.3V	
Typical Power Consumption (watt)	5.6/5.7	3.96	N/A	
Weight	550	570	600	
Physical Size(mm)	317.3x242.0x6.0	317.3x242.0x5.9	317.3x242.0x6.5	
Electrical Interface	1 channel LVDS	1 channel LVDS	1 channel LVDS	
Support Color	262K colors (RGB 6-bit data driver)	262,144	262,144	

LCD 14.1 inch

Item	Specification			
Viewing Angle (degree)				
Horizontal: Right/Left	40/40	45/45	40/40	
Vertical: Upper/Lower	10/30	15/35	20/40	
Temperature Range(°C)				
Operating	0 to +50	0 to +50	0 to +50	
Storage (shipping)	-20 to +60	-25 to +60	-20 to +60	

LCD Inverter

Item	Specification
Vendor & model name	Darfon/V189-301GP
Brightness conditions	N/A
Input voltage (V)	9~21
Input current (mA)	2.56 (max)
Output voltage (V, rms)	780V (2000V for kick off)
Output current (mA, rms)	6.5 (max)
Output voltage frequency (k Hz)	65K Hz (max)

AC Adaptor

Item	Specification
Input rating	90V AC to 264V AC, 47Hz to 63Hz
Maximum input AC current	1.7A
Inrush current	220A@115VAC 220A@230VAC
Efficiency	82% min. @115VAC input full load

System Power Management

ACPI mode	Power Management
Mech. Off (G3)	All devices in the system are turned off completely.
Soft Off (G2/S5)	OS initiated shutdown. All devices in the system are turned off completely.
Working (G0/S0)	Individual devices such as the CPU and hard disc may be power managed in this state.
Suspend to RAM (S3)	CPU set power down VGA Suspend PCMCIA Suspend Audio Power Down Hard Disk Power Down CD-ROM Power Down Super I/O Low Power mode
Save to Disk (S4)	Also called Hibernation Mode. System saves all system states and data onto the disc prior to power off the whole system.

System Utilities

BIOS Setup Utility

The BIOS Setup Utility is a hardware configuration program built into your computer's BIOS (Basic Input/Output System).

Your computer is already properly configured and optimized, and you do not need to run this utility. However, if you encounter configuration problems, you may need to run Setup. Please also refer to Chapter 4 Troubleshooting when problem arises.

To activate the BIOS Utility, press **m** during POST (when "Press <F2> to enter Setup" message is prompted on the bottom of screen).

Press **m** to enter setup. The default parameter of F12 Boot Menu is set to "disabled". If you want to change boot device without entering BIOS Setup Utility, please set the parameter to "enabled".

Press <F12> during POST to enter multi-boot menu. In this menu, user can change boot device without entering BIOS SETUP Utility.

Phoenix TrustedCore Setup Utility			
Information	Main	Advanced Security Boot Exit	
CPU Type:	Genuine Intel® CPU	Help Item	
CPU Speed:	XXXXGHz		
IDE0 Model Name:	Intel Raid0	Menu Level ▶	
IDE0 Serial Number:	TSST CorpCD		
IDE1 Model Name:	MK3018GAP-(PM)		
IDE1 Serial Number:	Y2554027T		
ATAPI Model Name	Slimtype DVD-ROM LSD-081-(S		
System BIOS Version	V1.0		
VGA BIOS Version	ATI M9+XC V0.1		
Serial Number	XXXXXXXXXX		
Asset Tag Number	XXXXXXXXXX		
Product Name	TravelMate XXXX		
Manufacturer Name	Acer Inc.		
UUID:	XXXXXXXXXX		
↑↓←→ :Move Enter: Select +/-/PU/PD :Value F10: Save and Exit ESC:Exit F1: General Help F5: Previous Values F7: Optimized Defaults			

Navigating the BIOS Utility

There are six menu options: Info., Main, System Devices, Security, Boot, and Exit.

Follow these instructions:

- q To choose a menu, use the cursor left/right keys (zx).
- q To choose a parameter, use the cursor up/down keys (wy).
- q To change the value of a parameter, press por q.
- q A plus sign (+) indicates the item has sub-items. Press e to expand this item.
- q Press ^ while you are in any of the menu options to go to the Exit menu.
- q In any menu, you can load default settings by pressing t. You can also press u to save any changes made and exit the BIOS Setup Utility.

NOTE: You can change the value of a parameter if it is enclosed in square brackets. Navigation keys for a particular menu are shown on the bottom of the screen. Help for parameters are found in the Item Specific Help part of the screen. Read this carefully when making changes to parameter values. **Please note that system information is subject to different models.**

Information

NOTE: The following system information is subject change between models and is for reference only.

Phoenix TrustedCore Setup Utility Information		
CPU Type:	Genuine Intel® CPU	Help Item
CPU Speed:	XXXXGHz	
IDE0 Model Name:	Intel Raid0	Menu Level ▶
IDE0 Serial Number:	TSST CorpCD	
IDE1 Model Name:	MK3018GAP-(PM)	
IDE1 Serial Number:	Y2554027T	
ATAPI Model Name	Slimtype DVD-ROM LSD-081-(S	
System BIOS Version	V1.0	
VGA BIOS Version	ATI M9+XC V0.1	
Serial Number	XXXXXXXXXX	
Asset Tag Number	XXXXXXXXXX	
Product Name	TravelMate XXXX	
Manufacturer Name	Acer Inc.	
UUID:	XXXXXXXXXX	
↑↓←→ :Move Enter: Select +/-/PU/PD :Value F10: Save and Exit ESC:Exit F1: General Help F5: Previous Values F7: Optimized Defaults		

Parameter	Description
CPU Type	This field shows the CPU type for the system
CPU Speed	This field shows the CPU speed for the system
IDE0 Model Name	This field shows the model name of HDD installed on primary IDE master
IDE0 Serial Number	This field displays the serial number of HDD installed on primary IDE master
IDE1 Model Name	This field displays the model name of devices installed on secondary IDE master. The hard disk drive or optical drive model name is automatically detected by the system
IDE1 Serial Number	This field shows the serial number of devices installed on secondary IDE master
ATAPI Model Name	This field displays the ATAPI model name
System BIOS ver	Displays system BIOS version
VGA BIOS Ver	This field displays the VGA firmware version of the system
Serial Number	This field displays the serial number of this unit
Asset Tag Number	This field displays the asset tag number of the system
Product Name	This field shows product name of the system
Manufacturer Name	This field displays the manufacturer of this system
UUID Number	This will be visible only when an internal LAN device is present

Main

The Main screen displays a summary of your computer hardware information, and also includes basic setup parameters. It allows the user to specify standard IBM PC AT system parameters.

NOTE: The screen below is for reference only. Actual values may differ.

Phoenix - Award WorkstationBIOS CMOS Setup Utility			
Main			
System Time	[09 : 00: 00]	Help Item	
System Date	[01 : 01: 2007]		
System Memory	640KB	Menu Level ▶	
Extended Memory	XXX		
Video Memory	[8M]		
Quiet Boot	[Enabled]		
Network Boot	[Enabled]		
F12 Boot Menu	[Disabled]		
D2D Recovery	[Enabled]		
↑↓←→ :Move Enter: Select +/-/PU/PD :Value F10: Save and Exit ESC:Exit			
F1: General Help F5: Previous Values F7: Optimized Defaults			

The table below describes the parameters in this screen. Settings in **boldface** are the default and suggested parameter settings.

Parameter	Description	Format/Option
System Time	Sets the system time. The hours are displayed with 24-hour format	Format: HH:MM:SS (hour:minute:second)
System Date	Sets the system date	Format MM/DD/YYYY (month/day/year)
System Memory	This field reports the memory size of the system. Memory size is fixed to 640MB	
Extended Memory	This field reports the memory size of the extended memory in the system (Extended Memory size=Total memory size-1MB)	
Video Memory	Shows the VGA memory size	
Quiet Boot	Determines if Customer Logo will be displayed or not; shows Summary Screen is disabled or enabled Enabled: Customer Logo is displayed, and Summary Screen is disabled Disabled: Customer Logo is not displayed, and Summary Screen is enabled	Option: Enabled or Disabled
Network Boot	Enables or disables the system boot from LAN (remote server)	Option: Enabled or Disabled
F12 Boot Menu	Enables or disables Boot Menu during POST. Enabled: During quite boot, the OEM POST screen displays Press <F12>Change Boot Device Disabled: During quite boot, the OEM POST screen does not display Press <F12>Change Boot Device <i>Note: This Boot device change is applies to next boot only.</i>	Option: Disabled or Enabled
D2D Recovery	Enables or disables D2D Recovery function. The function allows the user to create a hidden partition on hard disc drive to store operation system and restore the system to factory defaults	Option: Enabled or Disabled

NOTE: The sub-items under each device will not be shown if the device control is set to disable or auto. This is because the user is not allowed to control the settings in these cases.

Advanced

The Advanced screen displays advanced settings in BIOS.

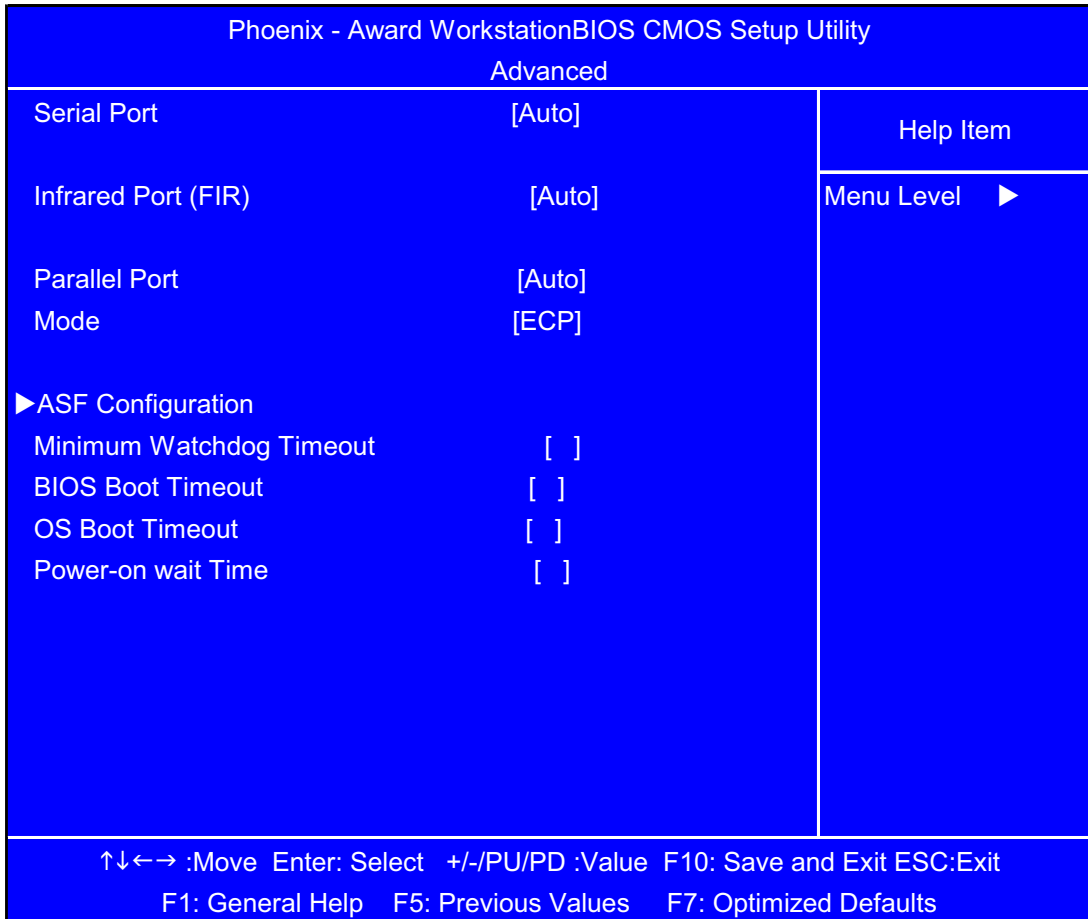

The table below describes the parameters in this screen. Settings in **boldface** are the default and suggested parameter settings.

Parameter	Description	Option
Serial port	Displays the setting of the serial port	Auto or Disabled
Infrared port	Displays the setting of the infrared port	Auto or Disabled
Parallel port	Displays the setting of the parallel port	Auto or Disabled
Mode	Displays the mode of the parallel port if enabled	ECP/SPP/EPP
ASF Configuration	Access the ASF Submenu for the following features:	Enter a figure in minutes
q Minimum Watchdog Timeout	q Minimum Watchdog Timeout —	
q BIOS Boot Timeout	q BIOS Boot Timeout —	
q OS Boot Timeout	q OS Boot Timeout —	
q Power-on wait Time	q Power-on wait Time —	

Security

The Security screen contains parameters that help safeguard and protect your computer from unauthorized use.

Phoenix - Award Workstation BIOS CMOS Setup Utility		
Security		
Supervisor Password Is	[Clear]	Help Item
User Password Is	[Clear]	
HDD Password Is	[Clear]	Menu Level ▶
Set Supervisor Password	[Enter]	
Set User Password	[Enter]	
Set HDD Password	[Enter]	
Password on Boot	[Disabled]	
Current TPM State		
Change TPM State	[No Change]	

↑↓←→ :Move Enter: Select +/-/PU/PD :Value F10: Save and Exit ESC:Exit
F1: General Help F5: Previous Values F7: Optimized Defaults

The table below describes the parameters in this screen. Settings in **boldface** are the default and suggested parameter settings.

Parameter	Description	Option
Supervisor Password Is	Shows the setting for the Supervisor password	Clear or Set
User Password Is	Shows the setting for the user password	Clear or Set
HDD Passworded Is	Shows the setting for the HDD password	Clear or Set
Set Supervisor Password	Press Enter to set the supervisor password. When set, this password protects the BIOS Setup Utility from unauthorized access. The user can not either enter the Setup menu nor change the value of parameters	
Set User Password	Press Enter to set the user password. When user password is set, this password protects the BIOS Setup Utility from unauthorized access. The user can enter Setup menu only and does not have right to change the value of parameters	
Set HDD Password	Press Enter to set the HDD password. When HDD password is set, this password protects the Primary HDD	
Password on Boot	Defines whether a password is required or not while the events defined in this group happen. The following sub-options are all requires the Supervisor password for changes and should be grayed out if the user password was used to enter setup	Disabled or Enabled
Current TPM State		
Change TPM State		

NOTE: When you are prompted to enter a password, you have three tries before the system halts. Don't forget your password. If you forget your password, you may have to return your notebook computer to your dealer to reset it.

Password Conventions

All the passwords must obey the following rules:

- q All the passwords can be set/cleared in BIOS Setup Security screen.
- q The password entry consists up to 8 alphanumeric characters. At least 1 character must be assigned in this field.

The valid keys are listed in the table below:

Symbol Character	Symbol Name
A — Z	Alphabet A through Z (Not Case Sensitive)
0 — 9	Numeric Characters
-	Dash
=	Equals Sign
[Left Bracket
]	Right Bracket
.	Period
,	Comma
;	Semi-colon

Symbol Character	Symbol Name
/	Slash
\	Back-slash

- q The maximum cycles to retry password is limited to 3.
- q User cannot change/remove password during resuming from S4.
- q Finger print: support 10 fingers - Upack/Authentic modules.

Setting a Password

Perform the following steps to set the supervisor, user, or HDD password.

NOTE: The following example uses the Supervisor Password screens. The User and HDD Password screens are identical.

1. Use the ↑ and ↓ keys to highlight the **Set Supervisor Password** parameter and press the **Enter** key. The Set Supervisor Password box appears:

Set Supervisor Password

Enter New Password []

Confirm New Password []

2. Type a password in the **Enter New Password** field. The password length can not exceeds 8 alphanumeric characters (A-Z, a-z, 0-9, not case sensitive). Retype the password in the **Confirm New Password** field.

IMPORTANT: Be careful when typing the password as the characters do not appear on the screen.

3. Press **Enter**. After setting the password, the computer sets the Supervisor Password Is parameter to **Set**.
4. If desired, you can opt to enable the **Password on Boot** parameter.
5. When you are done, save the changes and exit the BIOS Setup Utility.

Removing a Password

Follow these steps:

1. Use the ↑ and ↓ keys to highlight the **Set Supervisor Password** parameter and press the **Enter** key. The Set Password box appears:

Set Supervisor Password

Enter current password []

Enter New Password []

Confirm New Password []

2. Type the current password in the **Enter Current Password** field and press **Enter**.
3. Press **Enter** twice **without** typing anything in the Enter New Password and Confirm New Password fields. The computer then sets the Supervisor Password parameter to **Clear**.
4. When you have changed the settings, save the changes and exit the BIOS Setup Utility.

Changing a Password

1. Use the ↑ and ↓ keys to highlight the **Set Supervisor Password** parameter and press the **Enter** key. The Set Password box appears:

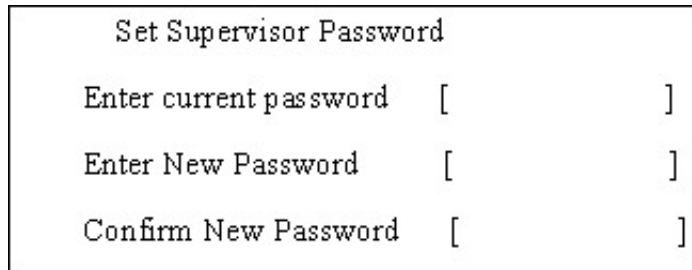

The screenshot shows a BIOS screen titled "Set Supervisor Password". It contains three input fields, each with a label and a pair of square brackets for text entry:

- Enter current password []
- Enter New Password []
- Confirm New Password []

2. Type the current password in the **Enter Current Password** field and press **Enter**.
3. Type a password in the **Enter New Password** field. Retype the password in the **Confirm New Password** field.
4. Press **Enter**. After setting the password, the computer sets the Supervisor Password Is parameter to **Set**.
5. If desired, you can enable the **Password on Boot** parameter.
6. When you are done, save the changes and exit the BIOS Setup Utility.

If the verification is OK, the screen will display as following.

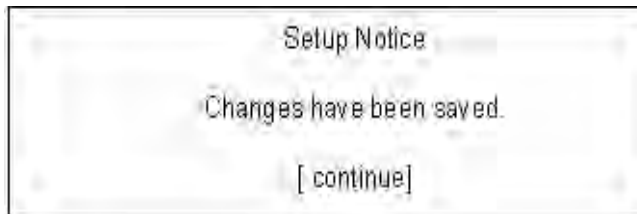

The screenshot shows a BIOS screen titled "Setup Notice". The text on the screen reads:

Changes have been saved.
[continue]

The password setting is complete after the user presses **Enter**.

If the current password entered does not match the actual current password, the screen will show you the Setup Warning.

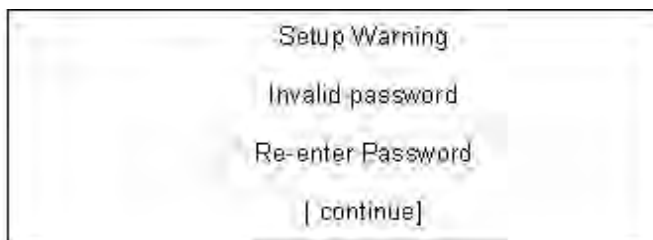

The screenshot shows a BIOS screen titled "Setup Warning". The text on the screen reads:

Invalid password
Re-enter Password
[continue]

If the new password and confirm new password strings do not match, the screen will display the following message.



Boot

This menu allows the user to decide the order of boot devices to load the operating system. Bootable devices includes the distette drive in module bay, the onboard hard disk drive and the CD-ROM in module bay.

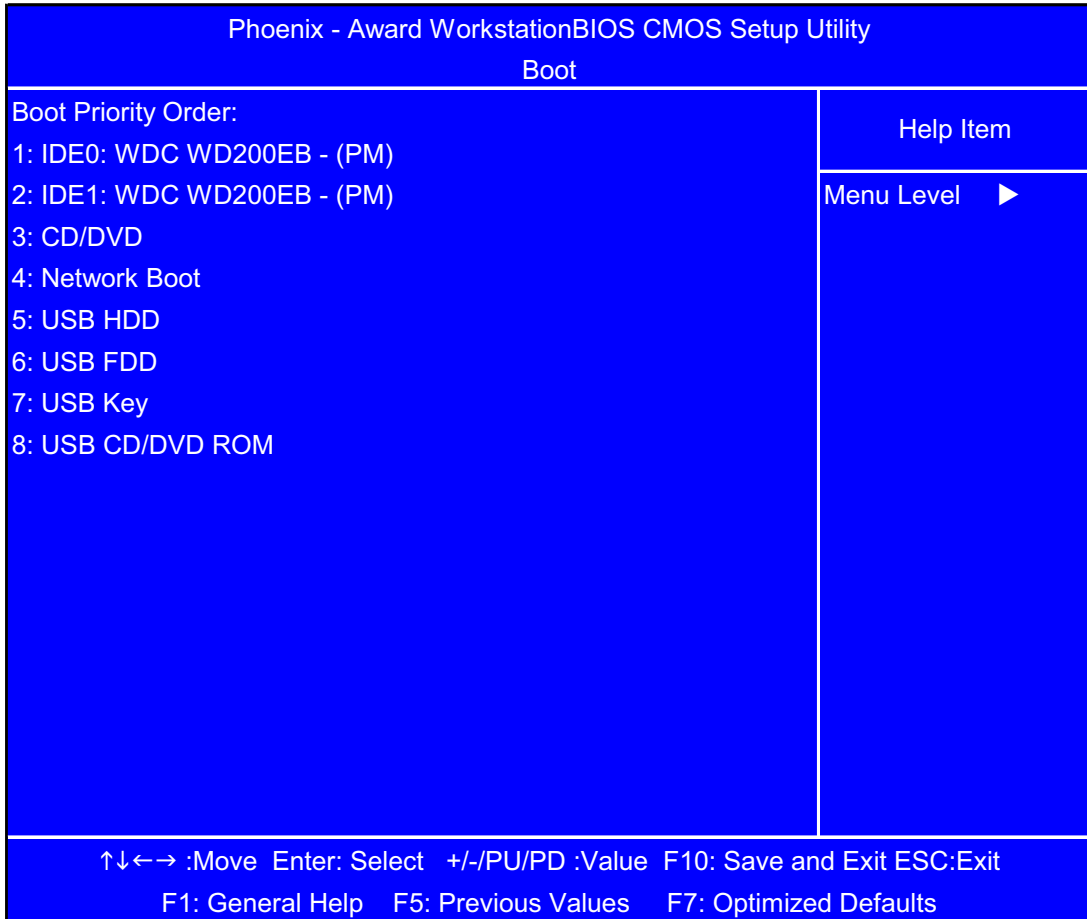

Use ↑ or ↓ to select a device, then press <F6> to move it up the List, or <F5> to move it down the list. Press <Esc> to escape the menu

Exit

The Exit screen contains parameters that help safeguard and protect your computer from unauthorized use.

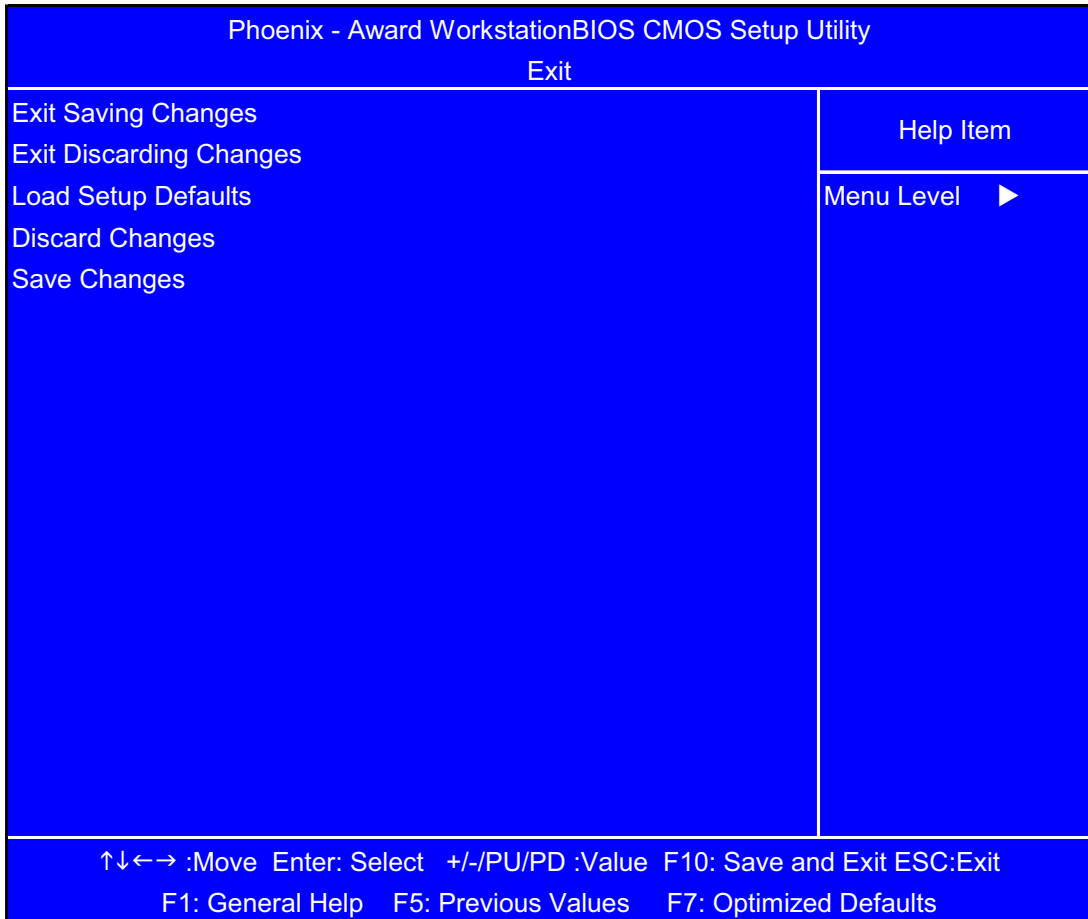

The table below describes the parameters in this screen.

Parameter	Description
Exit Saving Changes	Exit System Setup and save your changes to CMOS.
Exit Discarding Changes	Exit utility without saving setup data to CMOS.
Load Setup Defaults	Load default values for all SETUP item.
Discard Changes	Load previous values from CMOS for all SETUP items.
Save Changes	Save Setup Data to CMOS.

BIOS Flash Utility

The BIOS flash memory update is required for the following conditions:

- q New versions of system programs
- q New features or options
- q Restore a BIOS when it becomes corrupted.

Use the Phlash utility to update the system BIOS flash ROM.

NOTE: If you do not have a crisis recovery diskette at hand, then you should create a **Crisis Recovery Diskette** before you use the Phlash utility.

NOTE: Do not install memory-related drivers (XMS, EMS, DPMS) when you use the Phlash.

NOTE: Please use the AC adaptor power supply when you run the Phlash utility. If the battery pack does not contain enough power to finish BIOS flash, you may not boot the system because the BIOS is not completely loaded.

Follow the steps below to run the Phlash.

1. Prepare a bootable diskette.
2. Copy the flash utilities to the bootable diskette.
3. Then boot the system from the bootable diskette. The flash utility has auto-execution function.

Machine Disassembly and Replacement

This chapter contains step-by-step procedures on how to disassemble the notebook computer for maintenance and troubleshooting.

To disassemble the computer, you need the following tools:

- q Wrist grounding strap and conductive mat for preventing electrostatic discharge
- q Small Philips screw driver
- q Philips screwdriver
- q Plastic flat head screw driver
- q Tweezers

NOTE: The screws for the different components vary in size. During the disassembly process, group the screws with the corresponding components to avoid mismatch when putting back the components. When you remove the stripe cover, please be careful not to scrape the cover.

General Information

Before You Begin

Before proceeding with the disassembly procedure, make sure that you do the following:

1. Turn off the power to the system and all peripherals.
2. Unplug the AC adapter and all power and signal cables from the system.

Disassembly Procedure Flowcharts

The following flowcharts give you a graphic representation on the entire disassembly sequence and instructs you on the components that need to be removed during servicing. For example, if you want to remove the system board, you must first remove the keyboard, then disassemble the inside assembly frame in that order.

Main Unit Disassembly Flowchart

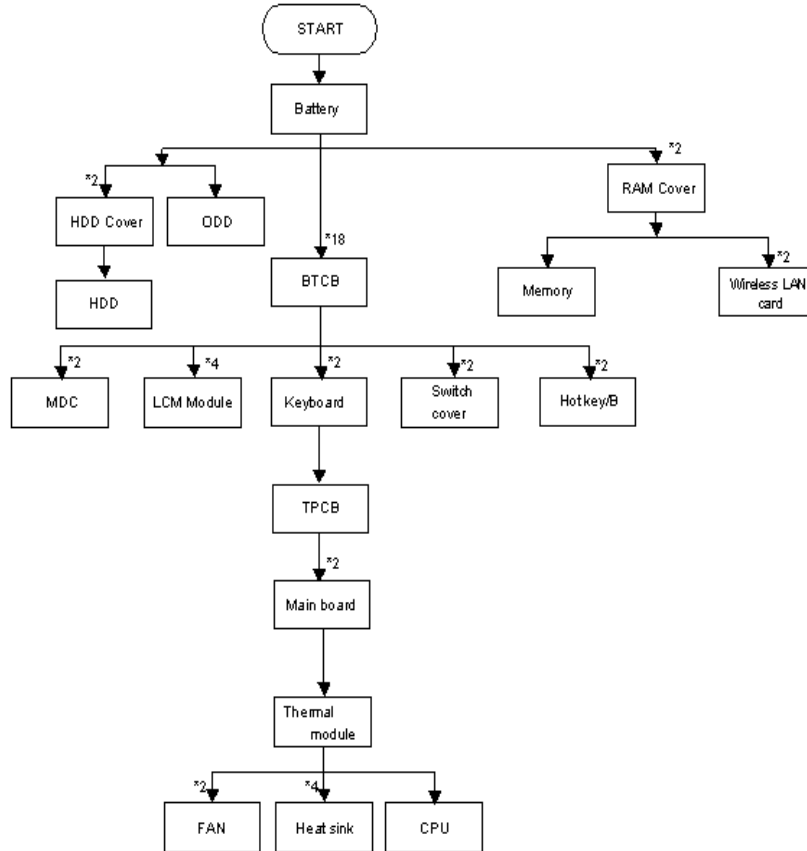

LCM Module Disassembly Flowchart

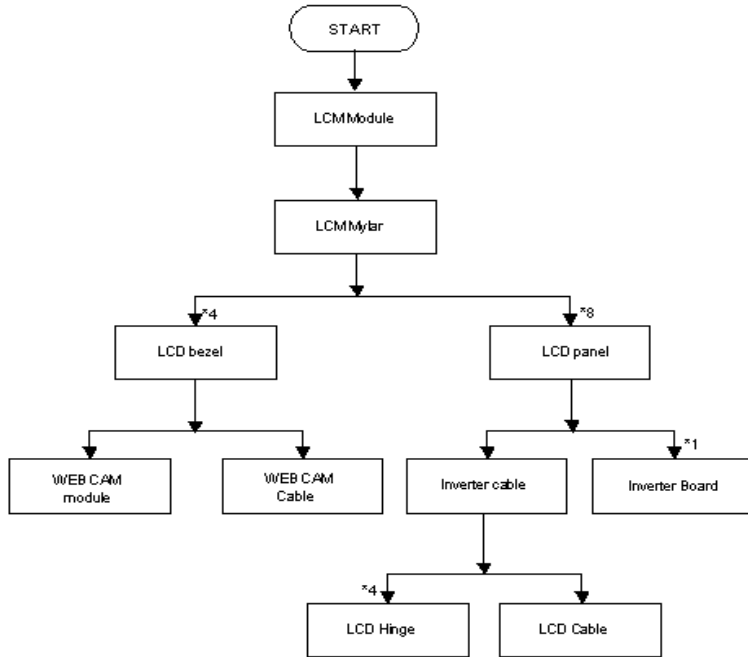

Main Unit Disassembly Procedure

Removing the Battery Pack

1. Turn the computer over. Release the battery lock as shown.



2. Push the release latch, the battery pops up.



3. Remove the battery.



Removing the Cover Securing Screws and Covers

1. Locate and loosen the seventeen (17) screws as shown.



NOTE: It is not necessary to remove the screws from the cover.

2. Locate and remove the memory and HDD cover screws as shown.



3. Remove the memory cover as shown.



4. Remove the HDD cover as shown.



Removing the HDD

1. Locate the plastic tab on the HDD.



-
2. Place one hand on the computer for stability and grasp the HDD removal tag.



3. Pull away from the connector and upward as shown to remove the HDD from the chassis.



Removing the Memory Module

1. Push the two release levers on the memory module outward as shown.

NOTE: The memory module lifts upward during release.



2. Pull the memory module away from the socket.



Removing the Wireless Card

NOTE: Fine tweezers are required for this procedure.

1. Locate the three antenna wires (white tape, red tape and no tape) on the left-hand side of the memory bay.



2. Using fine tweezers, grip the white taped wire and pull upward until it is released from the board.



3. Repeat for the red taped and no tape wires.
4. Remove cables to access Wireless Card.
5. Locate and remove the three screws as shown.

NOTE: The Wireless Card lifts up automatically once the screws are removed.



6. Grip card and pull away from socket as shown.



Removing the ODD

1. Push and hold the ODD latch as shown.



2. Remove ODD.



Removing Dummy Trays

1. Locate Dummy Tray 1 and press the cover inwards as shown.



2. Remove Dummy Tray 1



3. Locate Dummy Tray 2 and press the release button as shown.



4. Remove Dummy Tray 2.



Removing the Switch Cover

CAUTION: Using tools to remove the Switch Cover may cause damage to the outer casing. It is recommended that only fingers are used to remove the Switch Cover.

1. Turn the computer over. Locate and remove the two securing screws as shown.



2. Open the LCM module fully to expose the Switch Cover.



3. Grip the Switch Cover as shown and pull upward to remove.



4. Using two hands, remove the Switch Cover from the chassis.



Removing the Keyboard

1. Locate and remove the two screws as shown.



2. Using both hands, lift the top edge of the keyboard as shown.



3. Turn the keyboard over, as shown, to expose the cables.



4. Using fine tweezers, release the first cable lock as shown and remove the cable from the socket.

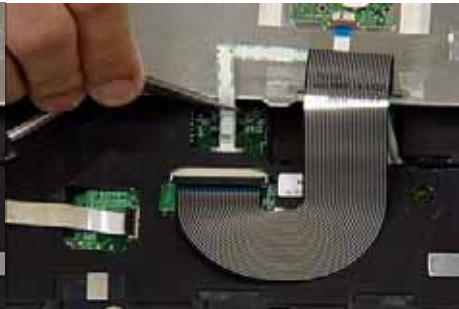
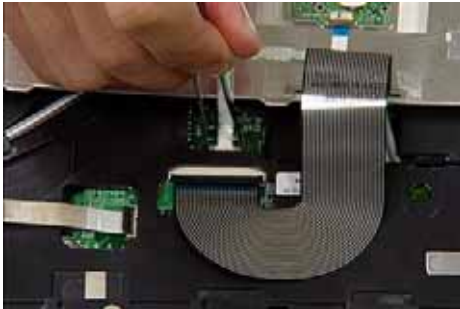

5. Using fine tweezers, release the second cable lock as shown and remove the cable from the socket.

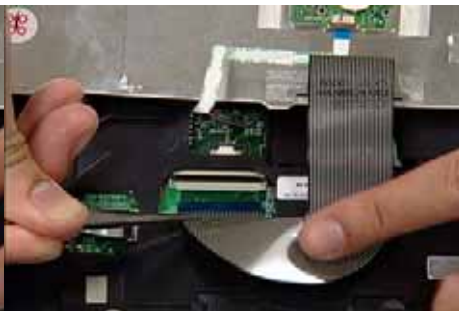
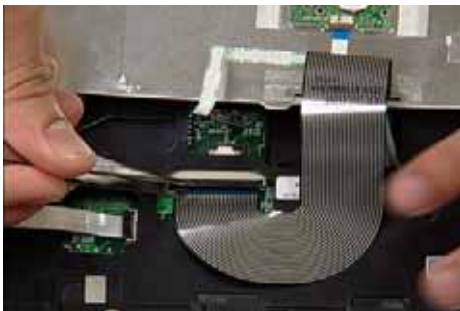

6. Remove keyboard from chassis.



Disconnecting the TouchPad

1. Disconnect the first cable by releasing the locking latch and removing the cable as shown.



2. Disconnect the second cable by releasing the locking latch and removing the cable as shown.
NOTE: Move the cable away from the work area to allow access to the third cable.



3. Disconnect the third cable as shown.



Removing the Switch Board

1. Locate and remove the two screws as shown.



2. Remove the Switch Board from the chassis.



Removing the Modem Module

1. Disconnect the two cables from the Modem Module as shown.

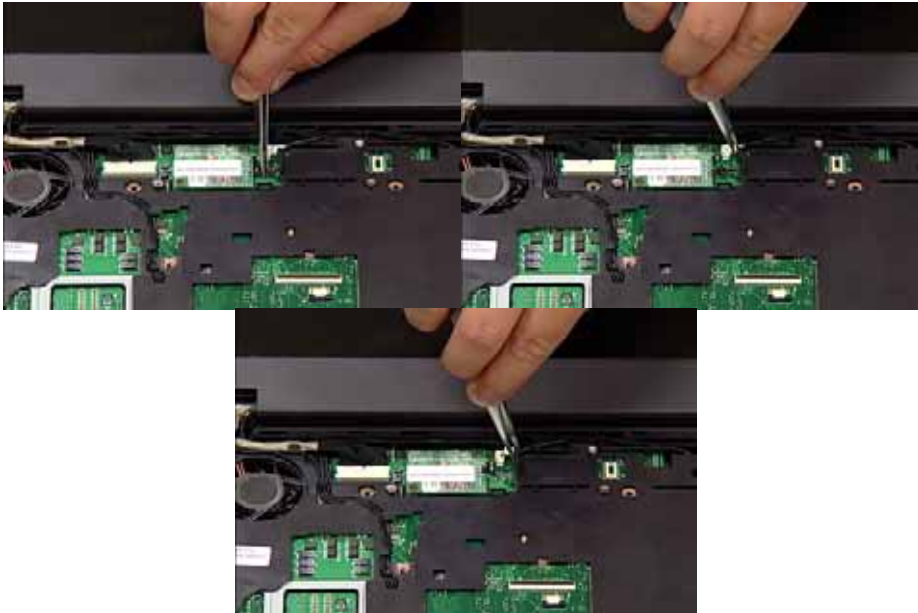

2. Locate and remove the two securing screws as shown.



3. Lift the Modem Module clear of the chassis.



Removing the Antenna Cables

1. Remove the Antenna Cables from the securing pins as shown.



2. Pull the three Antenna Cables from the underside of the computer through the mainboard as shown.



Removing the LCM Module

CAUTION: Ensure all cables are removed from securing pins before proceeding to avoid damage.

1. Disconnect the LCM Module cable as shown.



2. Locate and remove the four screws as shown.



3. Lift the LCM Module upward to remove from the chassis.



Removing the TouchPad

1. Lift the rear edge of the TouchPad Module first, as shown, then pull the module away from the mounting to clear the ports at the front of the computer.



Removing the Mainboard

1. Locate the three connectors (yellow markers) as shown.



2. Disconnect the connectors using tweezers as shown.

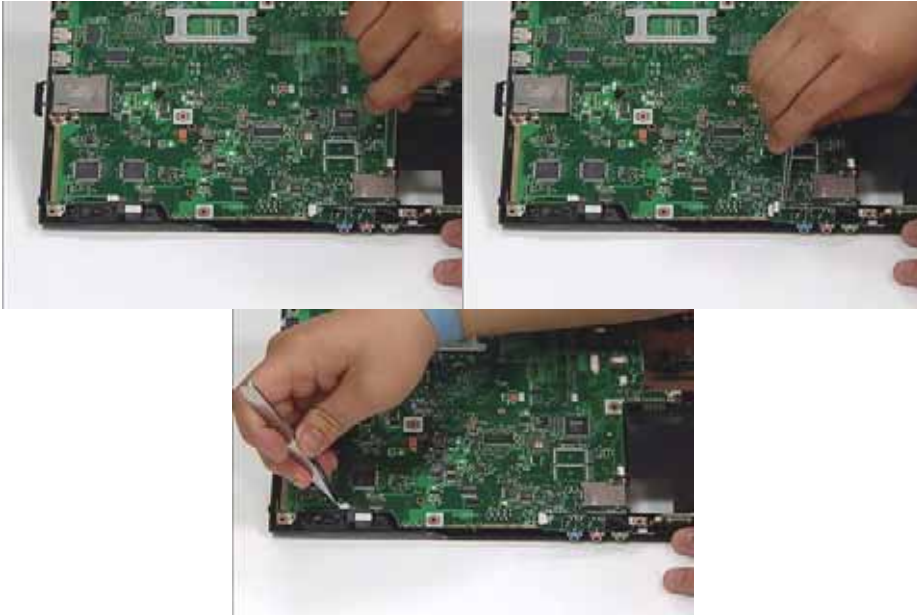

3. Locate and remove the two screws as shown to release the Mainboard.



4. Grip the mainboard from the front and lift up.

NOTE: If any resistance is met while removing the mainboard, ease the computer case outward to clear the obstruction.



5. Lift the mainboard clear of the chassis.



Removing the I/O Board

1. Locate and remove the two screws as shown.



2. Lift the board toward the front of the computer to clear the port and remove from the chassis.

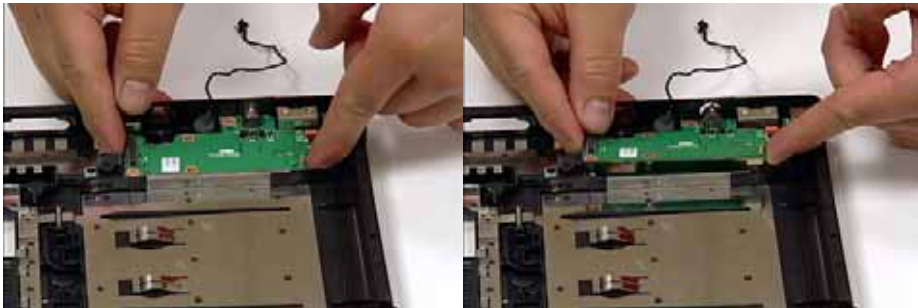

Removing the Heatsink and Fan Module

1. Turn the mainboard over. Locate and remove the five screws (red markers) and fan connector (yellow marker) from the mainboard.



2. Remove the Heatsink securing bracket as shown.



3. Remove the Heatsink as shown.



4. Steady the Mainboard with one hand and remove the Fan Module by lifting straight up.



Removing the CPU

1. Using a screw driver, unscrew the CPU counter clockwise.



2. Remove the CPU from the bracket as shown.



LCM Module Disassembly Procedure

Removing the LCM Bezel

CAUTION: When using tools, be careful not to scratch the computer casing.

1. Locate and remove the four mylar (small red markers) and two rubber (large red markers) screw covers as shown.

NOTE: Do not discard the screw covers — they are reusable.



2. Remove the six bezel securing screws.
3. Loosen the bezel by lifting all the edges upward as shown.

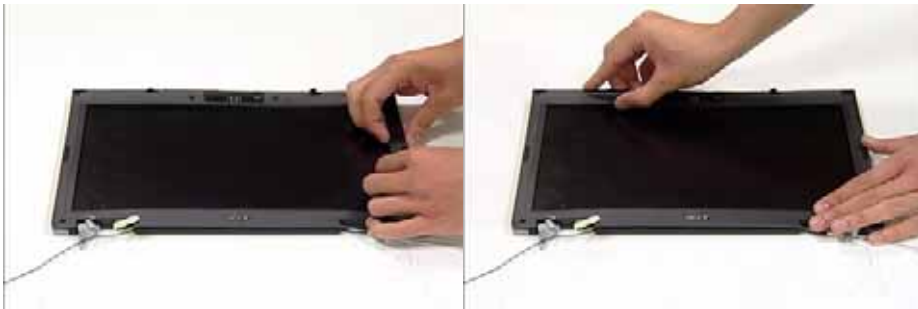

4. Push in the cover locks to allow the bezel to pass freely over them.



5. Remove the bezel from the LCM Module.



Removing the LCD Panel

1. Locate and remove the six screws as shown.



2. Locate the three panel connectors as shown. Disconnect the cables as shown.



-
3. Hold down the WebCam Module and remove the LCD panel by lifting the hinge as shown.



4. Locate and remove the Inverter Board screw as shown.



5. Grip the Inverter Board and lift upward to remove.



6. Grip the WebCam Module and lift upward to remove.



7. Turn the LCD panel over to expose the rear. Grip the LCM cable and lift upward to detach the adhesive pads.

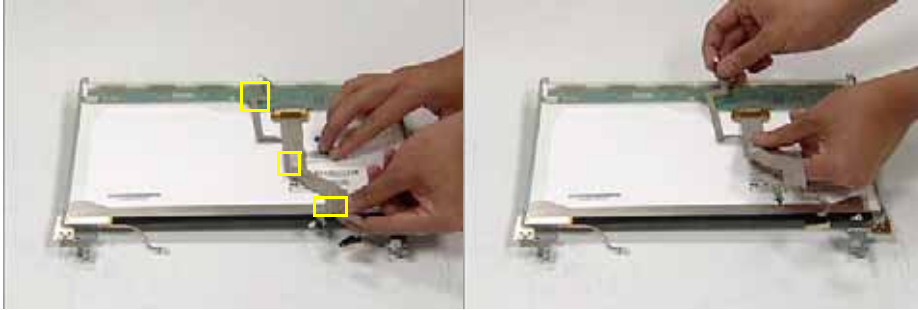

8. Hold the printed circuit board with one hand and disconnect the cable by pulling away from the connector.

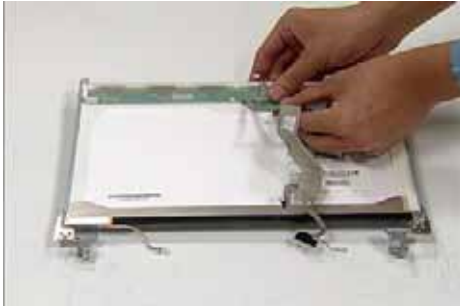

9. Locate and remove the four screws (two on each side) securing the LCD brackets to the LCD panel.

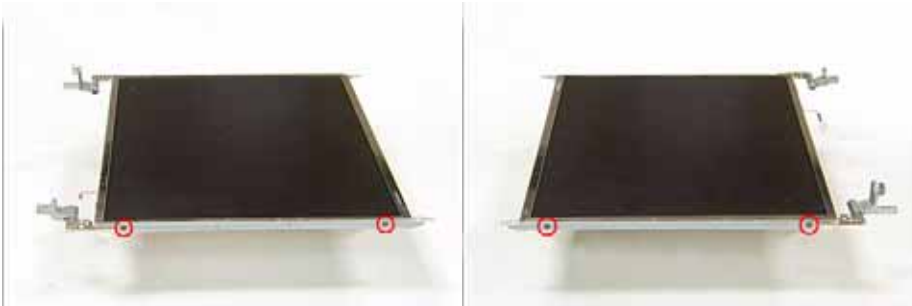

10. Remove the LCD brackets by pulling away from the LCD Panel as shown.



LCM Module Reassembly Procedure

Replacing the LCD Panel

1. Align the LCD brackets the four screw holes (two on each side) on the LCD Panel as shown.

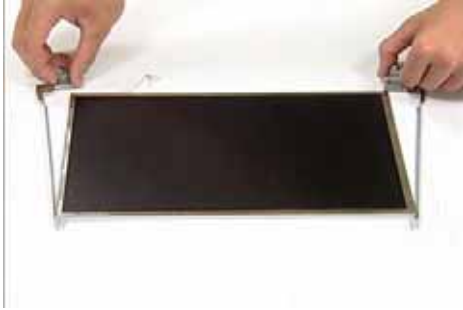

2. Secure the LCD brackets to the LCD panel.

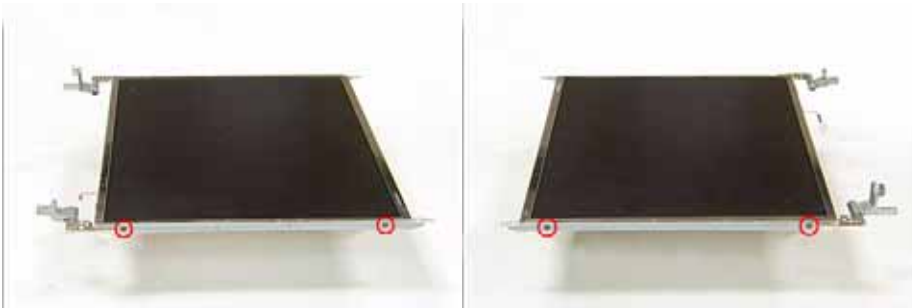

3. Insert the cable into the cable connector on the LCD Panel as shown.

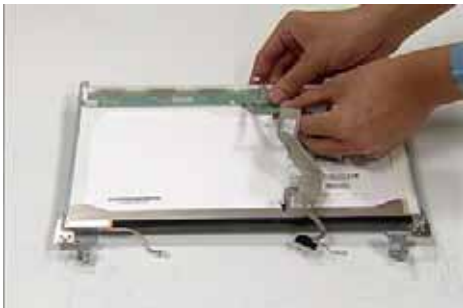

4. Align the LCD Panel cable as shown and press down to engage the adhesive pads.

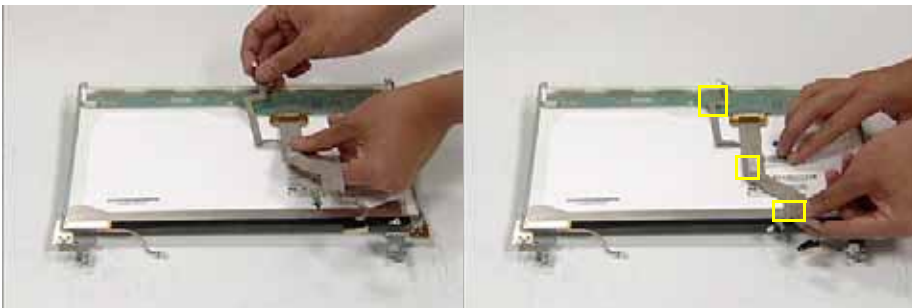

5. Place the WebCam Module in the mounting as shown.



6. Place the Inverter Board in the mounting and secure with the screw provided.

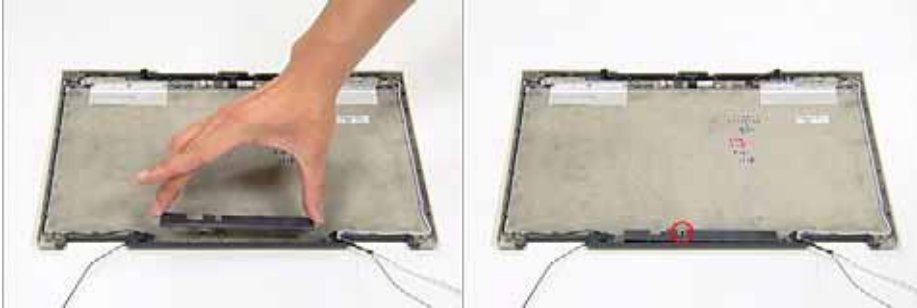

7. Place the LCD Panel in the mounting and secure the three panel connectors as shown.

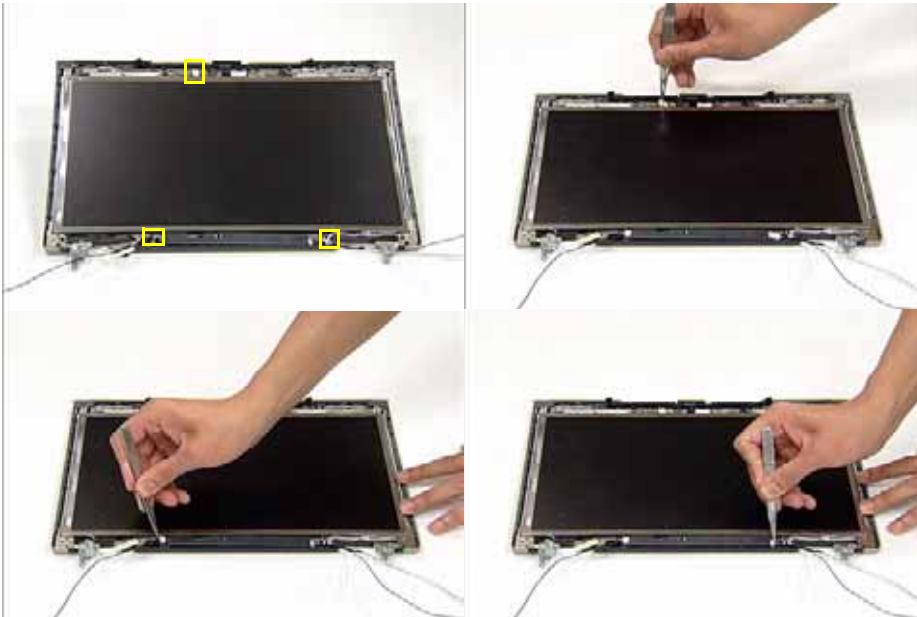

-
- Secure the LCD Panel with the six screws provided.



Replacing the LCM Bezel

- Locate the bezel correctly and press down the edges until there are no gaps between the bezel and the LCM Module,



- Secure the six screws provided and replace the mylar (small red markers) and rubber screw caps (large red markers).



Main Module Reassembly Procedure

Replacing the CPU

1. Insert the CPU into the CPU bracket as shown.



2. Using a screw driver, tighten the screw clockwise as shown to secure the CPU in place.



Replacing the Heatsink and Fan Module

1. Place the Fan Module in the mounting as shown.



2. Place the Heatsink as shown.



-
3. Align the Heatsink Securing Bracket as shown.



4. Secure the five screws and fan connector as shown.



Replacing the I/O Board

1. Insert the board rear edge first as shown.

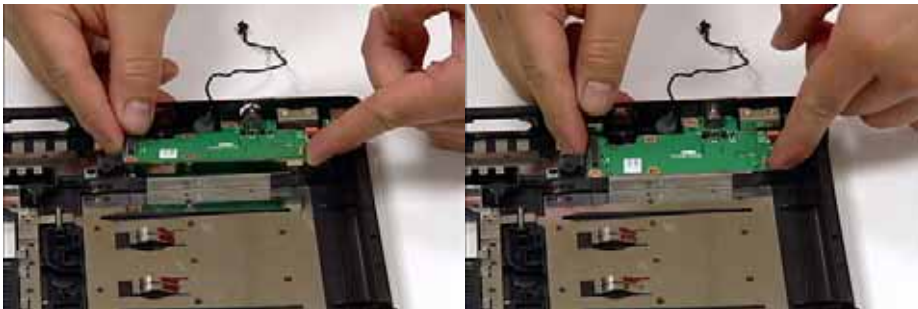

2. Replace the two screws as shown.



Replacing the Mainboard

1. Ensure that the Mainboard is face up (the Heatsink and CPU are not visible). Place the Mainboard in the chassis, rear edge first, and press down to install. Replace the two securing screws as shown.

NOTE: If any resistance is met while installing the mainboard, ease the computer case outward to clear the obstruction.



2. Replace the three connectors in the Mainboard sockets as shown.



3. Secure the Mainboard to the chassis using the two screws provided.



Replacing the TouchPad

1. Using both hands, replace the TouchPad, front edge first, as shown.

NOTE: Ensure that the TouchPad cables are accessible once the TouchPad is in place and that all cables pass through the casing properly.

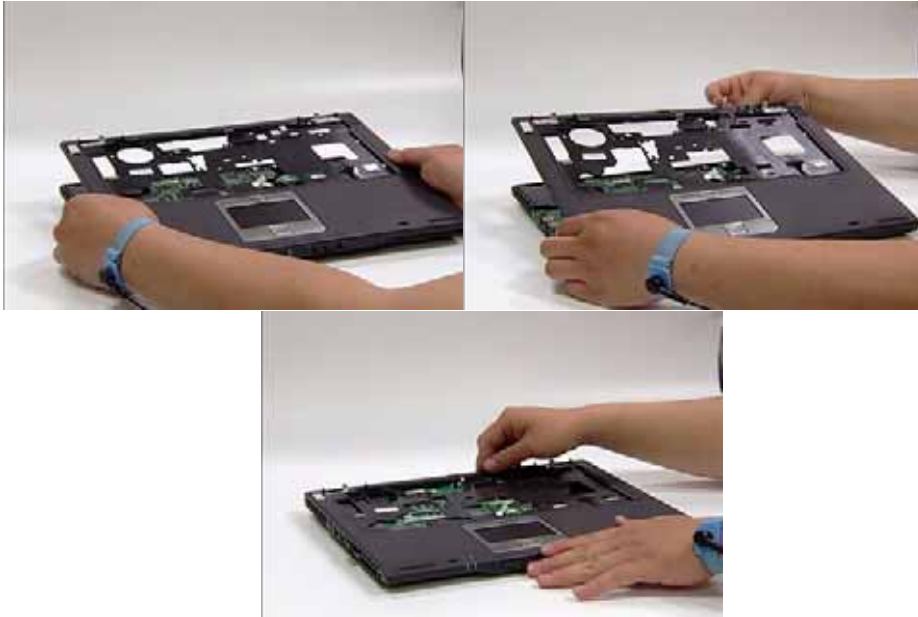

Replacing the LCM Module

1. Align the four screw holes on the LCM Module hinges with the corresponding screw holes on the chassis. Lower the LCM Module into position as shown. Ensure that the LCM cables are inserted through the aperture before proceeding (yellow marker).



2. Secure the four screws to hold the LCM in place on the chassis.



Replacing the Antenna Cables

1. Ensure that the three LCM Module cable pass through the Mainboard and are accessible from the underside of the computer. Place the three cables in the wiring conduit and secure in place using the cable pins on the chassis.

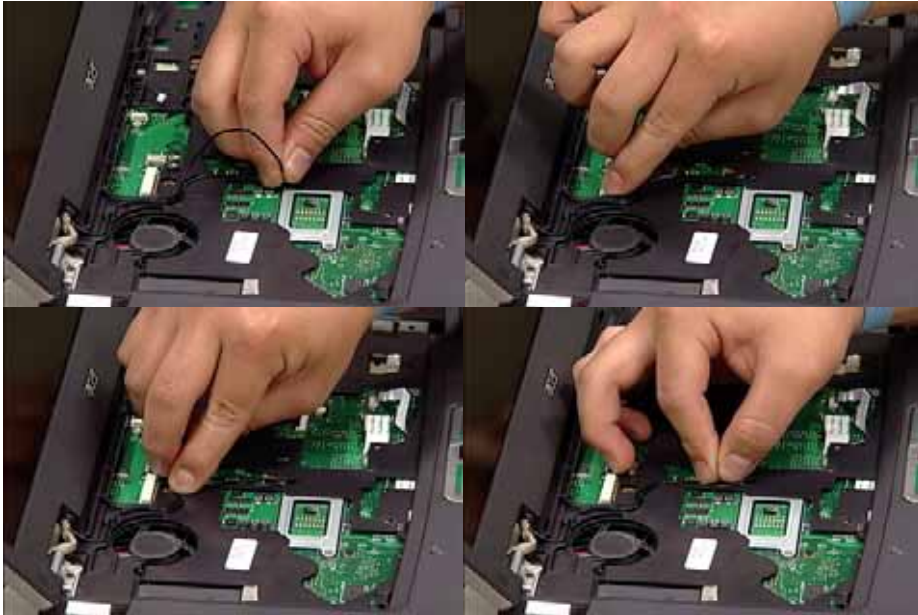

2. Connect the LCM Module cable to the connector on the chassis as shown.



Replacing the Modem

1. Place the Modem in the mounting as shown. Insert the two screws provided to hold the Modem in place.



-
2. Reconnect the Modem cables as shown.



Replacing the Switch Board

1. Place the Switch Board in the mounting as shown.



2. Secure the Switch Board in place using the screw provided.



Reconnecting the TouchPad

1. Replace the connector as shown.



2. Insert the first cable as shown and lock the latch to secure the cable in place.



3. Insert the second cable as shown and lock the latch to secure the cable in place.



Replacing the Keyboard

1. Using fine tweezers, insert the thicker cable into the socket and secure the locking latch as shown.

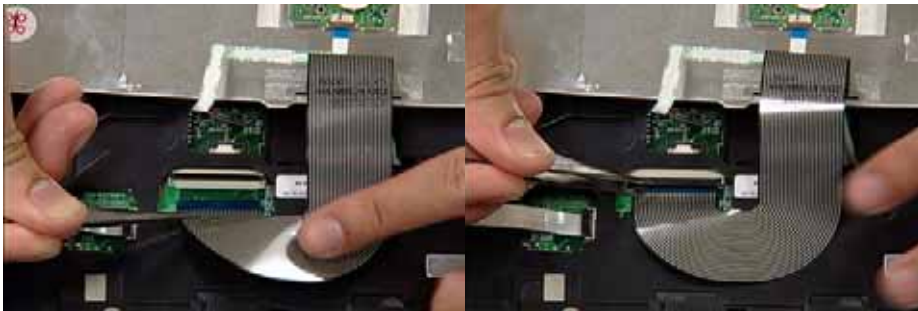

2. Using fine tweezers, insert the remaining cable into the socket and secure the locking latch as shown.

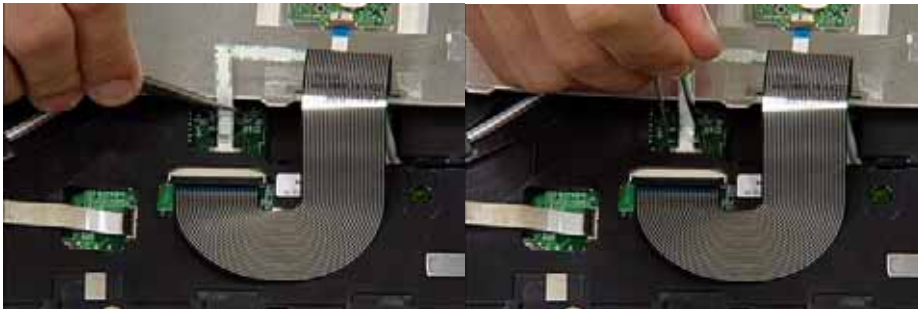

3. Turn the keyboard over and place the front edge first into the mounting.



4. Push the Keyboard into place toward the TouchPad and secure using the two screws provided.



5. Turn the Computer over and insert the screw as shown.



Replacing the Switch Cover

1. Turn the computer over. Place the Switch Cover as shown and press down until no gaps are visible between the cover and the chassis.



-
2. Close the LCM Module. Locate and replace the two screws as shown.



Replacing the Dummy Trays

1. Insert Dummy Tray 2 and push into the slot until flush with the chassis cover.



2. Insert Dummy Tray 1 and push into the slot until flush with the chassis cover.

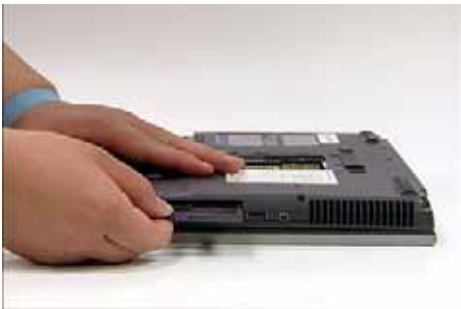

Replacing the ODD

1. Insert the ODD and push into the slot until flush with the chassis cover.

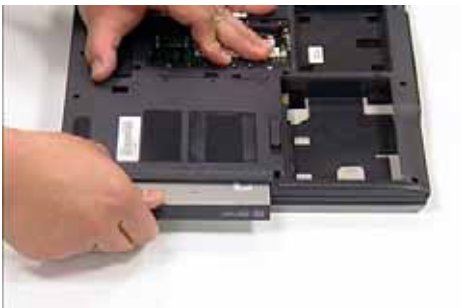

Replacing the Wireless Card

1. Ensure the card is positioned label upwards as shown and push into the connector.

NOTE: The card remains at an angle until the screws are inserted.



2. Secure the card in position using the two screws provided.



3. Reconnect the three Antenna Cables as shown, pushing down firmly to connect the cables.

Cable Color	Connector Number
No Tape	1
White Tape	2
Red Tape	3



Replacing the Memory Module

1. Push the memory module into the socket and press downward until it clicks into place.



Replacing the HDD

1. Place the HDD in the mounting, rear edge first as shown.



2. Push firmly toward the connector to secure the HDD.



Replacing the Covers

1. Replace the HDD cover as shown.



2. Replace the two screws to secure the cover in place.



3. Replace the memory cover as shown.



4. Replace the two screws to secure the cover in place.



5. Replace the seventeen (17) screws to secure the cover in place.



Replacing the Battery Pack

1. Place the battery in the cradle rear edge first as shown.



2. Push the battery downward until it clicks in to place.



3. Engage the battery lock as shown.



Troubleshooting

Use the following procedure as a guide for computer problems.

NOTE: The diagnostic tests are intended to test only Acer products. Non-Acer products, prototype cards, or modified options can give false errors and invalid system responses.

1. Obtain the failing symptoms in as much detail as possible.
2. Verify the symptoms by attempting to re-create the failure by running the diagnostic test or by repeating the same operation.
3. Use the following table with the verified symptom to determine which page to go to.

Symptoms (Verified)	Go To
Power failure. (The power indicator does not go on or stay on.)	"Power System Check" on page 99.
POST does not complete. No beep or error codes are indicated.	"Power-On Self-Test (POST) Error Message" on page 102 "Undetermined Problems" on page 114
POST detects an error and displayed messages on screen.	"Error Message List" on page 103
Other symptoms (i.e. LCD display problems or others).	"Power-On Self-Test (POST) Error Message" on page 102
Symptoms cannot be re-created (intermittent problems).	Use the customer-reported symptoms and go to "Power-On Self-Test (POST) Error Message" on page 102 "Intermittent Problems" on page 113 "Undetermined Problems" on page 114

System Check Procedures

External Diskette Drive Check

Do the following to isolate the problem to a controller, driver, or diskette. A write-enabled, diagnostic diskette is required.

NOTE: Make sure that the diskette does not have more than one label attached to it. Multiple labels can cause damage to the drive or cause the drive to fail.

Do the following to select the test device.

1. Boot from the diagnostics diskette and start the diagnostics program.
2. See if FDD Test is passed as the program runs to FDD Test.
3. Follow the instructions in the message window.

If an error occurs with the internal diskette drive, reconnect the diskette connector on the system board.

If the error still remains:

1. Reconnect the external diskette drive/DVD-ROM module.
2. Replace the external diskette drive/CD-ROM module.
3. Replace the main board.

External CD-ROM Drive Check

Do the following to isolate the problem to a controller, drive, or CD-ROM. Make sure that the CD-ROM does not have any label attached to it. The label can cause damage to the drive or can cause the drive to fail.

Do the following to select the test device:

1. Boot from the diagnostics diskette and start the diagnostics program.
2. See if CD-ROM Test is passed when the program runs to CD-ROM Test.
3. Follow the instructions in the message window.

If an error occurs, reconnect the connector on the System board. If the error still remains:

1. Reconnect the external diskette drive/CD-ROM module.
2. Replace the external diskette drive/CD-ROM module.
3. Replace the main board.

Keyboard or Auxiliary Input Device Check

Remove the external keyboard if the internal keyboard is to be tested.

If the internal keyboard does not work or an unexpected character appears, make sure that the flexible cable extending from the keyboard is correctly seated in the connector on the system board.

If the keyboard cable connection is correct, run the Keyboard Test.

If the tests detect a keyboard problem, do the following one at a time to correct the problem. Do not replace a non-defective FRU:

1. Reconnect the keyboard cables.
2. Replace the keyboard.
3. Replace the main board.

The following auxiliary input devices are supported by this computer:

- q Numeric keypad
- q External keyboard

If any of these devices do not work, reconnect the cable connector and repeat the failing operation.

Memory check

Memory errors might stop system operations, show error messages on the screen, or hang the system.

1. Boot from the diagnostics diskette and start the doagmpstotics program (please refer to main board).
2. Go to the diagnostic memory in the test items.
3. Press F2 in the test items.
4. Follow the instructions in the message window.

NOTE: Make sure that the DIMM is fully installed into the connector. A loose connection can cause an error.

Power System Check

To verify the symptom of the problem, power on the computer using each of the following power sources:

1. Remove the battery pack.
2. Connect the power adapter and check that power is supplied.
3. Disconnect the power adapter and install the charged battery pack; then check that power is supplied by the battery pack.

If you suspect a power problem, see the appropriate power supply check in the following list:

- q “Check the Power Adapter” on page 100
- q “Check the Battery Pack” on page 101

Check the Power Adapter

Unplug the power adapter cable from the computer and measure the output voltage at the plug of the power adapter cable. See the following figure

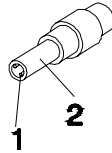

Pin 1: +19 to +20.5V
Pin 2: 0V, Ground

1. If the voltage is not correct, replace the power adapter.
2. If the voltage is within the range, do the following:
 - q Replace the System board.
 - q If the problem is not corrected, see “Undetermined Problems” on page 114.
 - q If the voltage is not correct, go to the next step.

NOTE: An audible noise from the power adapter does not always indicate a defect.

3. If the power-on indicator does not light up, check the power cord of the power adapter for correct continuity and installation.
4. If the operational charge does not work, see “Check the Battery Pack” on page 101.

Check the Battery Pack

To check the battery pack, do the following:

From Software:

1. Check out the Power Management in control Panel
2. In Power Meter, confirm that if the parameters shown in the screen for Current Power Source and Total Battery Power Remaining are correct.
3. Repeat the steps 1 and 2, for both battery and adapter.
4. This helps you identify first the problem is on recharging or discharging.

From Hardware:

1. Power off the computer.
2. Remove the battery pack and measure the voltage between battery terminals 1(+) and 6(ground). See the following figure

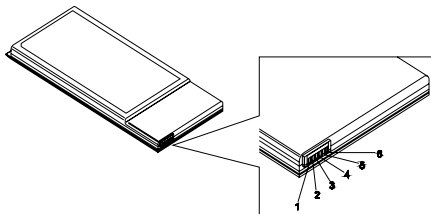

3. If the voltage is still less than 7.5 Vdc after recharging, replace the battery.

To check the battery charge operation, use a discharged battery pack or a battery pack that has less than 50% of the total power remaining when installed in the computer.

If the battery status indicator does not light up, remove the battery pack and let it return to room temperature. Re-install the battery pack.

If the charge indicator still does not light up, replace the battery pack. If the charge indicator still does not light up, replace the DC/DC charger board.

Touchpad Check

If the touchpad doesn't work, do the following actions one at a time to correct the problem. Do not replace a non-defective FRU:

1. Reconnect the touchpad cables.
2. Replace the touchpad.
3. Replace the system board.

After you use the touchpad, the pointer drifts on the screen for a short time. This self-acting pointer movement can occur when a slight, steady pressure is applied to the touchpad pointer. This symptom is not a hardware problem. No service actions are necessary if the pointer movement stops in a short period of time.

Power-On Self-Test (POST) Error Message

The POST error message index lists the error message and their possible causes. The most likely cause is listed first.

NOTE: Perform the FRU replacement or actions in the sequence shown in FRU/Action column, if the FRU replacement does not solve the problem, put the original part back in the computer. Do not replace a non-defective FRU.

This index can also help you determine the next possible FRU to be replaced when servicing a computer.

If the symptom is not listed, see “Undetermined Problems” on page 114.

The following lists the error messages that the BIOS displays on the screen and the error symptoms classified by function.

NOTE: Most of the error messages occur during POST. Some of them display information about a hardware device, e.g., the amount of memory installed. Others may indicate a problem with a device, such as the way it has been configured.

NOTE: If the system fails after you make changes in the BIOS Setup Utility menus, reset the computer, enter Setup and install Setup defaults or correct the error.

Index of Error Messages

Error Code List

Error Codes	Error Messages
006	Equipment Configuration Error Causes: 1. CPU BIOS Update Code Mismatch 2. IDE Primary Channel Master Drive Error (The causes will be shown before "Equipment Configuration Error")
010	Memory Error at xxxx:xxxx:xxxxh (R:xxxxh, W:xxxxh)
070	Real Time Clock Error
071	CMOS Battery Bad
072	CMOS Checksum Error
110	System disabled. Incorrect password is specified.
<No error code>	Battery critical LOW In this situation BIOS will issue 4 short beeps then shut down system, no message will show.
<No error code>	Thermal critical High In this situation BIOS will shut down system, not show message.

Error Message List

Error Messages	FRU/Action in Sequence
Failure Fixed Disk	Reconnect hard disk drive connector. "Load Default Settings" in BIOS Setup Utility. Hard disk drive System board
Stuck Key	see "Keyboard or Auxiliary Input Device Check" on page 98.
Keyboard error	see "Keyboard or Auxiliary Input Device Check" on page 98.
Keyboard Controller Failed	see "Keyboard or Auxiliary Input Device Check" on page 98.
Keyboard locked - Unlock key switch	Unlock external keyboard
Monitor type does not match CMOS - Run Setup	Run "Load Default Settings" in BIOS Setup Utility.
Shadow RAM Failed at offset: nnnn	BIOS ROM System board
System RAM Failed at offset: nnnn	DIMM System board
Extended RAM Failed at offset: nnnn	DIMM System board
System battery is dead - Replace and run Setup	Replace RTC battery and Run BIOS Setup Utility to reconfigure system time, then reboot system.
System CMOS checksum bad - Default configuration used	RTC battery Run BIOS Setup Utility to reconfigure system time, then reboot system.
System timer error	RTC battery Run BIOS Setup Utility to reconfigure system time, then reboot system. System board

Error Message List

Error Messages	FRU/Action in Sequence
Real time clock error	RTC battery Run BIOS Setup Utility to reconfigure system time, then reboot system. System board
Previous boot incomplete - Default configuration used	Run "Load Default Settings" in BIOS Setup Utility. RTC battery System board
Memory size found by POST differed from CMOS	Run "Load Default Settings" in BIOS Setup Utility. DIMM System board
Diskette drive A error	Check the drive is defined with the proper diskette type in BIOS Setup Utility See "External Diskette Drive Check" on page 98.
Incorrect Drive A type - run SETUP	Check the drive is defined with the proper diskette type in BIOS Setup Utility
System cache error - Cache disabled	System board
CPU ID:	System board
DMA Test Failed	DIMM System board
Software NMI Failed	DIMM System board
Fail-Safe Timer NMI Failed	DIMM System board
Device Address Conflict	Run "Load Default Settings" in BIOS Setup Utility. RTC battery System board
Allocation Error for device	Run "Load Default Settings" in BIOS Setup Utility. RTC battery System board
Failing Bits: nnnn	DIMM BIOS ROM System board
Fixed Disk n	None
Invalid System Configuration Data	BIOS ROM System board
I/O device IRQ conflict	Run "Load Default Settings" in BIOS Setup Utility. RTC battery System board
Operating system not found	Enter Setup and see if fixed disk and drive A: are properly identified. Diskette drive Hard disk drive System board

Error Message List

No beep Error Messages	FRU/Action in Sequence
No beep, power-on indicator turns off and LCD is blank.	Power source (battery pack and power adapter). See "Power System Check" on page 99.. Ensure every connector is connected tightly and correctly. Reconnect the DIMM. LED board. System board.
No beep, power-on indicator turns on and LCD is blank.	Power source (battery pack and power adapter). See "Power System Check" on page 99.. Reconnect the LCD connector Hard disk drive LCD inverter ID LCD cable LCD Inverter LCD System board
No beep, power-on indicator turns on and LCD is blank. But you can see POST on an external CRT.	Reconnect the LCD connectors. LCD inverter ID LCD cable LCD inverter LCD System board
No beep, power-on indicator turns on and a blinking cursor shown on LCD during POST.	Ensure every connector is connected tightly and correctly. System board
No beep during POST but system runs correctly.	Speaker System board

Phoenix BIOS Beep Codes

Code	Beeps	POST Routine Description
02h		Verify Real Mode
03h		Disable Non-Maskable Interrupt (NMI)
04h		Get CPU type
06h		Initialize system hardware
08h		Initialize chipset with initial POST values
09h		Set IN POST flag
0Ah		Initialize CPU registers
0Bh		Enable CPU cache
0Ch		Initialize caches to initial POST values
0Eh		Initialize I/O component
0Fh		Initialize the local bus IDE
10h		Initialize Power Management
11h		Load alternate registers with initial POST values
12h		Restore CPU control word during warm boot
13h		Initialize PCI Bus Mastering devices
14h		Initialize keyboard controller
16h	1-2-2-3	BIOS ROM checksum
17h		Initialize cache before memory autosize
18h		8254 timer initialization
1Ah		8237 DMA controller initialization
1Ch		Reset Programmable Interrupt Controller
20h	1-3-1-1	Test DRAM refresh
22h	1-3-1-3	Test 8742 Keyboard Controller
24h		Set ES segment register to 4 GB
26h		Enable A20 line
28h		Autosize DRAM
29h		Initialize POST Memory Manager
2Ah		Clear 215 KB base RAM
2Ch	1-3-4-1	RAM failure on address line xxxx
2Eh	1-3-4-3	RAM failure on data bits xxxx of low byte of memory bus
2Fh		Enable cache before system BIOS shadow
30h	1-4-1-1	RAM failure on data bits xxxx of high byte of memory bus
32h		Test CPU bus-clock frequency
33h		Initialize Phoenix Dispatch Manager
36h		Warm start shut down
38h		Shadow system BIOS ROM
3Ah		Autosize cache
3Ch		Advanced configuration of chipset registers
3Dh		Load alternate registers with CMOS values
42h		Initialize interrupt vectors
45h		POST device initialization

Code	Beeps	POST Routine Description
46h	2-1-2-3	Check ROM copyright notice
48h		Check video configuration against CMOS
49h		Initialize PCI bus and devices
4Ah		Initialize all video adapters in system
4Bh		QuietBoot start (optional)
4Ch		Shadow video BIOS ROM
4Eh		Display BIOS copyright notice
50h		Display CPU type and speed
51h		Initialize EISA board
52h		Test keyboard
54h		Set key click if enabled
58h	2-2-3-1	Test for unexpected interrupts
59h		Initialize POST display service
5Ah		Display prompt "Press F2 to enter SETUP"
5Bh		Disable CPU cache
5Ch		Test RAM between 512 and 640 KB
60h		Test extended memory
62h		Test extended memory address lines
64h		Jump to User Patch1
66h		Configure advanced cache registers
67h		Initialize Multi Processor APIC
68h		Enable external and CPU caches
69h		Setup System Management Mode (SMM) area
6Ah		Display external L2 cache size
6Bh		Load custom defaults (optional)
6Ch		Display shadow-area message
6Eh		Display possible high address for UMB recovery
70h		Display error messages
72h		Check for configuration errors
76h		Check for keyboard errors
7Ch		Set up hardware interrupt vectors
7Eh		Initialize coprocessor if present
80h		Disable onboard Super I/O ports and IRQs
81h		Late POST device initialization
82h		Detect and install external RS232 ports
83h		Configure non-MCD IDE controllers
84h		Detect and install external parallel ports
85h		Initialize PC-compatible PnP ISA devices
86h		Re-initialize onboard I/O ports
87h		Configure Motherboard Configurable Devices (optional)
88h		Initialize BIOS Area
89h		Enable Non-Maskable Interrupts (NMIs)
8Ah		Initialize Extended BIOS Data Area
8Bh		Test and initialize PS/2 mouse

Code	Beeps	POST Routine Description
8Ch		Initialize floppy controller
8Fh		Determine number of ATA drives (optional)
90h		Initialize hard-disk controllers
91h		Initialize local-bus hard-disk controllers
92h		Jump to UserPatch2
93h		Build MPTABLE for multi-processor boards
95h		Install CD ROM for boot
96h		Clear huge ES segment register
97h		Fixup Multi Processor table
98h	1-2	Search for option ROMs. One long, two short beeps on checksum failure.
99h		Check for SMART drive (optional)
9Ah		Shadow option ROMs
9Ch		Set up Power Management
9Dh		Initialize security engine (optional)
9Eh		Enable hardware interrupts
9Fh		Determine number of ATA and SCSI drives
A0h		Set time of day
A2h		Check key lock
A4h		Initialize Typematic rate
A8h		Erase F2 prompt
AAh		Scan for F2 key stroke
ACh		Enter SETUP
A Eh		Clear Boot flag
B0h		Check for errors
B2h		POST done- prepare to boot operating system
B4h	1	One short beep before boot
B5h		Terminate QuietBoot (optional)
B6h		Check password (optional)
B9h		Prepare Boot
BAh		Initialize DMI parameters
BBh		Initialize PnP Option ROMs
BCh		Clear parity checkers
BDh		Display MultiBoot menu
BEh		Clear screen (optional)
BFh		Check virus and backup reminders
C0h		Try to boot with INT 19
C1h		Initialize POST Error Manager (PEM)
C2h		Initialize error logging
C3h		Initialize error display function
C4h		Initialize system error handler
C5h		PnPnd dual CMOS (optional)
C6h		Initialize notebook docking (optional)
C7h		Initialize notebook docking late
C8h		Force check (optional)
C9h		Extended checksum (optional)

Code	Beeps	POST Routine Description
D2h		Unknown interrupt

Code	Beeps	POST Routine Description
E0h		Initialize the chipset
E1h		Initialize the bridge
E2h		Initialize the CPU
E3h		Initialize the system timer
E4h		Initialize system I/O
E5h		Check force recovery boot
E6h		Checksum BIOS ROM
E7h		Go to BIOS
E8h		Set Huge Segment
E9h		Initialize Multi Processor
EAh		Initialize OEM special code
EBh		Initialize PIC and DMA
ECh		Initialize Memory type
EDh		Initialize Memory size
EEh		Shadow Boot Block
EFh		System memory test
F0h		Initialize interrupt vectors
F1h		Initialize Run Time Clock
F2h		Initialize video
F3h		Initialize System Management Mode
F4h	1	Output one beep before boot
F5h		Boot to Mini DOS
F6h		Clear Huge Segment
F7h		Boot to Full DOS

Index of Symptom-to-FRU Error Message

LCD-Related Symptoms

Symptom / Error	Action in Sequence
LCD backlight doesn't work LCD is too dark LCD brightness cannot be adjusted LCD contrast cannot be adjusted	Enter BIOS Utility to execute "Load Setup Default Settings", then reboot system. Reconnect the LCD connectors. Keyboard (if contrast and brightness function key doesn't work). LCD inverter ID LCD cable LCD inverter LCD System board
Unreadable LCD screen Missing pels in characters Abnormal screen Wrong color displayed	Reconnect the LCD connector LCD inverter ID LCD cable LCD inverter LCD System board
LCD has extra horizontal or vertical lines displayed.	LCD inverter ID LCD inverter LCD cable LCD System board

Indicator-Related Symptoms

Symptom / Error	Action in Sequence
Indicator incorrectly remains off or on, but system runs correctly	Reconnect the inverter board Inverter board System board

Power-Related Symptoms

Symptom / Error	Action in Sequence
Power shuts down during operation	Power source (battery pack and power adapter). See "Power System Check" on page 99. Battery pack Power adapter Hard drive & battery connection board System board
The system doesn't power-on.	Power source (battery pack and power adapter). See "Power System Check" on page 99. Battery pack Power adapter Hard drive & battery connection board System board
The system doesn't power-off.	Power source (battery pack and power adapter). See "Power System Check" on page 99. Hold and press the power switch for more than 4 seconds. System board

Power-Related Symptoms

Symptom / Error	Action in Sequence
Battery can't be charged	See "Check the Battery Pack" on page 101. Battery pack System board

PCMCIA-Related Symptoms

Symptom / Error	Action in Sequence
System cannot detect the PC Card (PCMCIA)	PCMCIA slot assembly System board
PCMCIA slot pin is damaged.	PCMCIA slot assembly

Memory-Related Symptoms

Symptom / Error	Action in Sequence
Memory count (size) appears different from actual size.	Enter BIOS Setup Utility to execute "Load Default Settings, then reboot system. DIMM System board

Speaker-Related Symptoms

Symptom / Error	Action in Sequence
In Windows, multimedia programs, no sound comes from the computer.	Audio driver Speaker System board
Internal speakers make noise or emit no sound.	Speaker System board

Power Management-Related Symptoms

Symptom / Error	Action in Sequence
The system will not enter hibernation	See "Save to Disk (S4)" on page 42. Keyboard (if control is from the keyboard) Hard disk drive System board
The system doesn't enter hibernation mode and four short beeps every minute.	Press Fn+0 and see if the computer enters hibernation mode. Touchpad Keyboard Hard disk connection board Hard disk drive System board
The system doesn't enter standby mode after closing the LCD	See "Save to Disk (S4)" on page 42. LCD cover switch System board
The system doesn't resume from hibernation mode.	See "Save to Disk (S4)" on page 42. Hard disk connection board Hard disk drive System board
The system doesn't resume from standby mode after opening the LCD.	See "Save to Disk (S4)" on page 42. LCD cover switch System board

Power Management-Related Symptoms

Symptom / Error	Action in Sequence
Battery fuel gauge in Windows doesn't go higher than 90%.	Remove battery pack and let it cool for 2 hours. Refresh battery (continue use battery until power off, then charge battery). Battery pack System board
System hangs intermittently.	Reconnect hard disk/CD-ROM drives. Hard disk connection board System board

Peripheral-Related Symptoms

Symptom / Error	Action in Sequence
System configuration does not match the installed devices.	Enter BIOS Setup Utility to execute "Load Default Settings", then reboot system. Reconnect hard disk/CD-ROM/diskette drives.
External display does not work correctly.	Press Fn+F5, LCD/CRT/Both display switching System board
USB does not work correctly	System board
Print problems.	Ensure the "Parallel Port" in the "Onboard Devices Configuration" of BIOS Setup Utility is set to Enabled. Onboard Devices Configuration Run printer self-test. Printer driver Printer cable Printer System Board
Serial or parallel port device problems.	Ensure the "Serial Port" in the Devices Configuration" of BIOS Setup Utility is set to Enabled. Device driver Device cable Device System board

Keyboard/Touchpad-Related Symptoms

Symptom / Error	Action in Sequence
Keyboard (one or more keys) does not work.	Reconnect the keyboard cable. Keyboard System board
Touchpad does not work.	Reconnect touchpad cable. Touchpad board System board

Modem-Related Symptoms

Symptom / Error	Action in Sequence
Internal modem does not work correctly.	Modem phone port modem combo board System board

NOTE: If you cannot find a symptom or an error in this list and the problem remains, see "Undetermined Problems" on page 114.

Intermittent Problems

Intermittent system hang problems can be caused by a variety of reasons that have nothing to do with a hardware defect, such as: cosmic radiation, electrostatic discharge, or software errors. FRU replacement should be considered only when a recurring problem exists.

When analyzing an intermittent problem, do the following:

1. Run the advanced diagnostic test for the system board in loop mode at least 10 times.
2. If no error is detected, do not replace any FRU.
3. If any error is detected, replace the FRU. Rerun the test to verify that there are no more errors.

Undetermined Problems

The diagnostic problems does not identify which adapter or device failed, which installed devices are incorrect, whether a short circuit is suspected, or whether the system is inoperative.

Follow these procedures to isolate the failing FRU (do not isolate non-defective FRU).

NOTE: Verify that all attached devices are supported by the computer.

NOTE: Verify that the power supply being used at the time of the failure is operating correctly. (See "Power System Check" on page 99.):

1. Power-off the computer.
2. Visually check them for damage. If any problems are found, replace the FRU.
3. Remove or disconnect all of the following devices:
 - q Non-Acer devices
 - q Printer, mouse, and other external devices
 - q Battery pack
 - q Hard disk drive
 - q DIMM
 - q CD-ROM/Diskette drive Module
 - q PC Cards
4. Power-on the computer.
5. Determine if the problem has changed.
6. If the problem does not recur, reconnect the removed devices one at a time until you find the failing FRU.
7. If the problem remains, replace the following FRU one at a time. Do not replace a non-defective FRU:
 - q System board
 - q LCD assembly

Jumper and Connector Locations

Top View

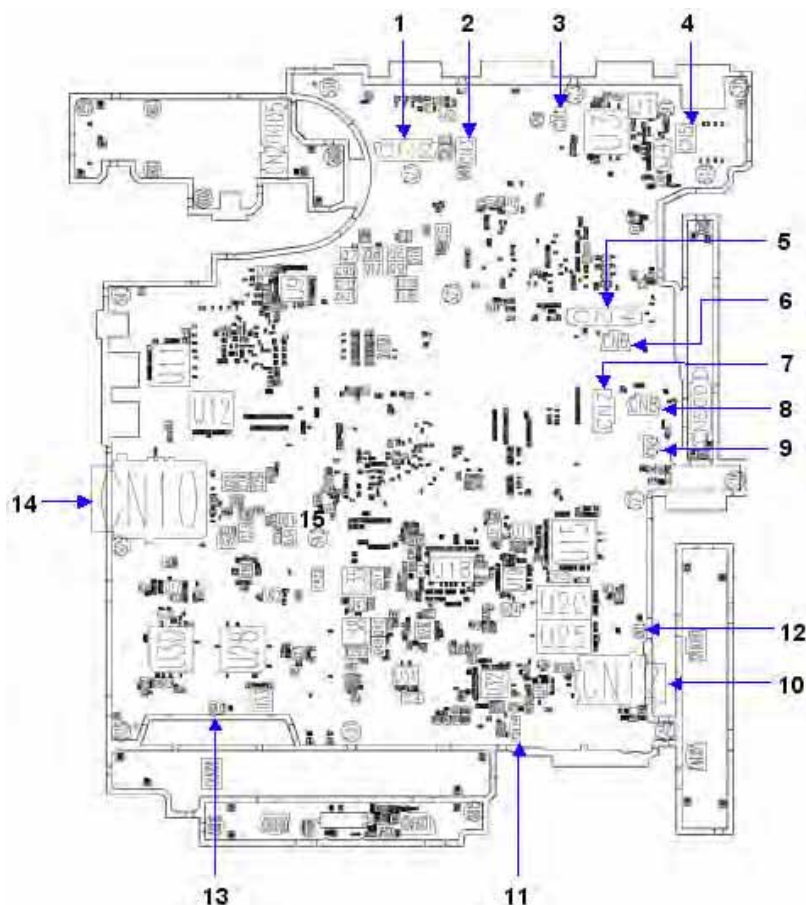

1	CN2	LCM Cable CNTR
2	CN3	MDC CNTR
3	CN1	MDC Cable CNTR
4	CN5	Hot key board CNTR
5	CN4	Key board FFC CNTR
6	CN6	Fine track FFC CNTR
7	CN7	Smart card FFC CNTR
8	CN8	Touch pad FFC CNTR
9	CN9	MIC cable CNTR
10	CN12	3G card CNTR
11	CN14	Blue tooth cable CNTR
12	CN11	Speaker cable CNTR
13	CN13	Speaker cable CNTR
14	CN10	5in1 card reader CNTR

Bottom View

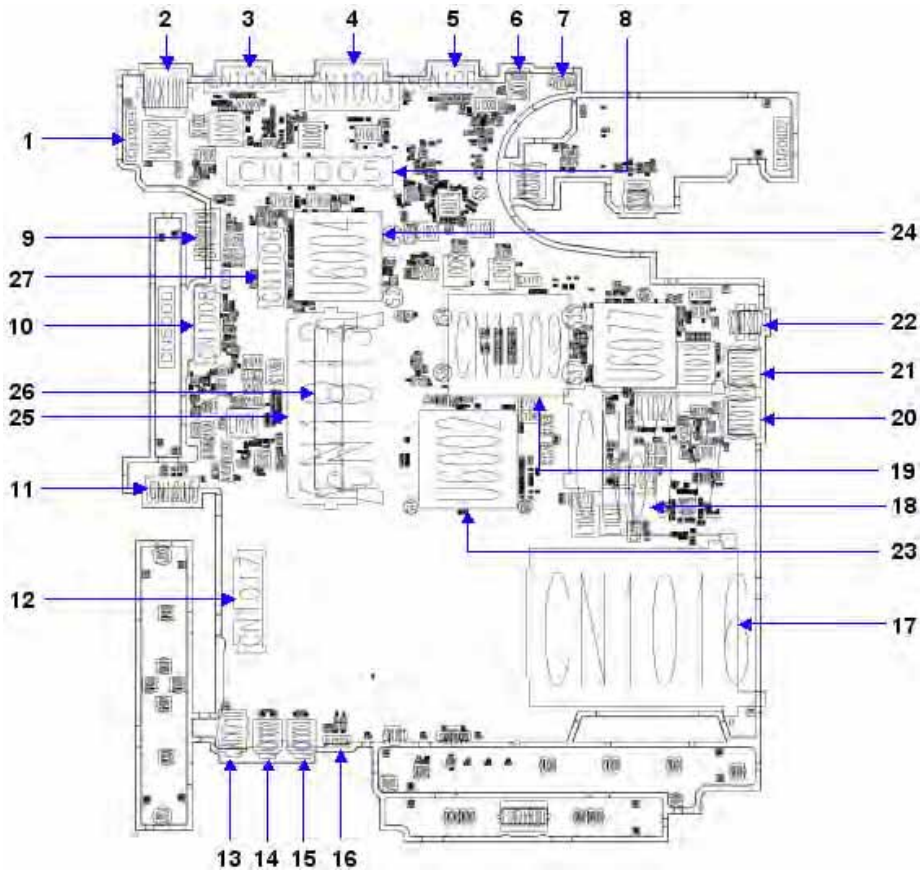

1	CN1004	MB & I/O board CNTR	15	Jack1003	Line-in jack
2	JACK1001	RJ-45	16	D1029	IR receiver
3	CN1001	Serial port	17	CN1016	PCI-E socket
4	CN1003	DVI port	18	CN6032	New card socket
5	CN1002	VGA port	19	CN1009	CPU socket
6	JACK1000	DC IN jack	20	CN1014	USB
7	CN1000	FAN cable CNTR	21	CN1010	USB
8	CN1005	Docking CNTR	22	CN1007	1394
9	CN1018	Second battery CNTR	23	U6002	North bridge
10	CN1008	ODD CNTR	24	U6004	South bridge
11	CN1015	Battery CNTR	25	CN1012	DIMM socket
12	CN1017	HDD CNTR	26	CN1013	DIMM socket
13	Jack710	Headphone jack	27	CN1006	W/LAN card CNTR
14	Jack1002	MIC jack			

Connector Descriptions

CN1 RJ11 Connector (4-PIN)

PIN No.	Signal name	I/O	PIN No.	Signal name	I/O
1	MDMRNG_DOCK	I/O	3	MDMRNG_DOCK	I/O
2	MDMTIP_DOCK	I/O	4	MDMTIP_DOCK	I/O

CN2 LCD I/F Connector (40-PIN)

PIN No.	Signal name	I/O	PIN No.	Signal name	I/O
1	+V5S	-	21	LVDS_TXDL2+	I
2	INV_PWM_3	I	22	GND	-
3	+V5S	-	23	LVDS_TXDL2-	I
4	GND	-	24	LVDS_TXDL1+	I
5	BKLTEN	I	25	GND	-
6	LVDS_TXCU+	I	26	LVDS_TXDL1-	I
7	GND	-	27	LVDS_TXDL0+	I
8	LVDS_TXCU-	I	28	GND	-
9	LVDS_TXDU2+	I	29	LVDS_TXDL0-	I
10	GND	-	30	LCM_DDCPDATA	I/O
11	LVDS_TXDU2-	I	31	GND	-
12	LVDS_TXDU1+	I	32	NC	-
13	GND	-	33	LCM_DDCPCLK	I/O
14	LVDS_TXDU1-	I	34	+V3S_DSC	-
15	LVDS_TXDU0+	I	35	GND	-
16	GND	-	36	+V3S	-
17	LVDS_TXDU0-	I	37	USB_PN6	I/O
18	LVDS_TXCL+	I	38	+V3S_LCM	-
19	GND	-	39	USB_PP6	I/O
20	LVDS_TXCL-	I	40	+V3S_LCM	-

Editor Note: These are samples taken from the source file **Pantanal service_HW_SPEC-070402.doc**. Are all of the descriptions required?

FRU (Field Replaceable Unit) List

This chapter gives you the FRU (Field Replaceable Unit) listing in global configurations of the TravelMate 6592/6592G. Refer to this chapter whenever ordering for parts to repair or for RMA (Return Merchandise Authorization).

Please note that WHEN ORDERING FRU PARTS, you should check the most up-to-date information available on your regional web or channel. For whatever reasons a part number change is made, it will not be noted on the printed Service Guide. For ACER AUTHORIZED SERVICE PROVIDERS, your Acer office may have a DIFFERENT part number code from those given in the FRU list of this printed Service Guide. You MUST use the local FRU list provided by your regional Acer office to order FRU parts for repair and service of customer machines.

NOTE: To scrap or to return the defective parts, you should follow the local government ordinance or regulations on how to dispose it properly, or follow the rules set by your regional Acer office on how to return it.

TravelMate 6592/6592G Exploded Diagram

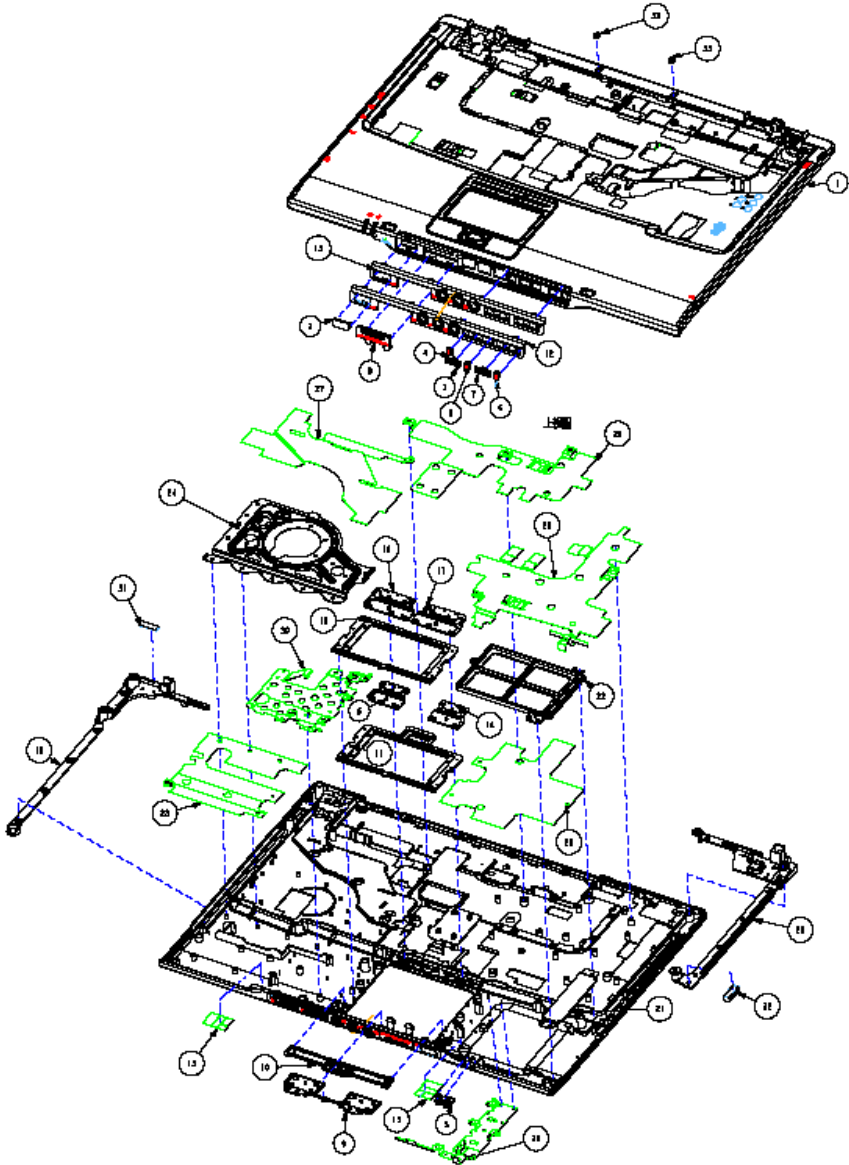







1			
2			
3			
4			
5			
6			
7			
8			
9			
10			
11			
12			

13			
14			
15			
16			
17			
18			
19			
20			
21			
22			
23			
24			
26			
27			
28			
29			
30			
31			
32			
33			
34			





Category	No.	Part Name and Description	Acer Part No.
ADAPTER			
		ADAPTER 135W 19V 3PIN W/LED DELTA ADP-135DB BBJF LF	AP.13501.004
		ADAPTER 135W 19V 3PIN LITE-ON PA-131-08 RI LF	AP.13503.006
		ADAPTER 135W 3PIN LSE SLS0317A19A52LF LF	AP.13506.002
BATTERY			
		BATTERY PACK SANYO LI-ION 8 CELL2.4, 4800MAH	BT.00803.019
		BATTERY PACK SONY LI-ION 8CELL2.4, 4800MAH	BT.00804.016
BOARD			
		MODEM BOARD FOXCONN T60M845.02	54.AAMVN.001
		WIRELESS LAN BOARD 802.11BG FOXCONN ABT_ATH5413BG	54.AAMVN.002

Category	No.	Part Name and Description	Acer Part No.
		WIRELESS LAN BOARD 802.11BG PCI EXPRESS FOXCONN ABT_BRM4318BG	54.AAMVN.003
		MINI WIRELESS BOARD 802.11 A/B/G MOW1 INTEL MM872612	KI.GLN01.001
		MINI WIRELESS BOARD 802.11 A/B/G MOW2 INTEL MM872659	KI.GLN01.002
		MINI WIRELESS BOARD 802.11 A/B/G ROW INTEL MM874511	KI.GLN01.003
		MINI WIRELESS BOARD 802.11 A/B/G JP INTEL MM874740	KI.GLN01.004
		MINI WIRELESS LAN BOARD 802.11BG INTEL WM3945AGBG	KI.GLN01.005
		BLUETOOTH BOARD FOXCONN T60H928.01	54.AAMVN.004
		I/O BOARD	55.AAMVN.001
 		LAUNCH BOARD (Above image is top view; below image is bottom view)	55.AAMVN.002
 		MEDIA BOARD (Above image is top view; below image is bottom view)	55.AAMVN.003

Category	No.	Part Name and Description	Acer Part No.
		AUDIO BOARD	55.AAMVN.004
		TOUCHPAD BOTTON BOARD	55.AAMVN.005
		TOUCHPAD SYNAPTICS TM61P-372	56.AAMVN.001
CABLE			
		POWER CORD 3PIN USA	27.AAMVN.001
		POWER CORD 3PIN EUR	27.AAMVN.002
		POWER CORD AUSTRALIA W/LABEL	27.AAMVN.003
		POWER CORD 3PIN UK	27.AAMVN.004
		POWER CORD 3PIN CHINA	27.AAMVN.005
		POWER CORD 3PIN SWISS	27.AAMVN.006
		POWER CORD SOUTH AFRICA (AIL)	27.AAMVN.007
		POWER CORD 3PIN SOUTH AFRICA	27.AAMVN.008
		POERR CORD 3PIN ITALIAN	27.AAMVN.009
		POWER CORD 3PIN DENMARK	27.AAMVN.010
		POWER CORD ISRAEL	27.AAMVN.011
		BLUETOOTH CABLE	50.AAMVN.002
		HOT KEYBOARD CABLE	50.AAMVN.003
		MIDEA BOARD CABLE	50.AAMVN.004

Category	No.	Part Name and Description	Acer Part No.
		AUDIO BOARD CABLE	50.AAMVN.005
		BUTTON BOARD CABLE 6 PINS	50.AAMVN.006
		BUTTON BOARD CABLE 12 PINS	50.AAMVN.007
		MODEM CABLE WITH RJ11 CONNECTOR	50.AAMVN.010
CASE/COVER/BRAKET ASSEMBLY			
		LOWER CASE	60.AAMVN.001
		UPPER CASE	60.AAMVN.002
		MIDDLE COVER	60.AAMVN.003

Category	No.	Part Name and Description	Acer Part No.
		ASSY THERMAL COVER	60.AAMVN.004
		SUPPORT COVER	60.AAMVN.005
		HDD COVER	42.AAMVN,001
		TOUCHPAD FRAME	42.AAMVN,002
		MINI DUMMY CARD	42.AAMVN.003
		PCMCIA DUMMY CARD	42.AAMVN.004

Category	No.	Part Name and Description	Acer Part No.
		TOUCHPAD BRACKET (Note: The ACTUAL spare part: touchpad bracket does NOT contain touchpad bracket gesket. However the touchpad bracket image here has the touchpad bracket gesket. If you need to replace the touchpad bracket, please take off the gesket from old touchpad bracket and then stick them to new touchpad bracket..	33.AAMVN.001
CPU/PROCESSOR			
		CPU INTEL YONAH CORE DUO FSB-667 1.66G 2M SL8VR	KC.23001.DTP
		CPU INTEL YONAH CORE DUO FSB-667 1.66G 2M SL9DM (NO VT)	KC.23E01.DTP
		CPU INTEL YONAH CORE DUO FSB-667 1.83G 2M SL8VQ	KC.24001.DTP
		CPU INTEL YONAH CORE DUO FSB-667 2.0G 2M SL8VP	KC.25001.DTP
		CPU INTEL YONAH CORE DUO FSB-667 2.16G 2M SL8VN	KC.26001.DTP
		CPU INTEL YONAH CORE SOLO FSB-667 1.66G 2M SL8VY	KC.13001.STP
COMBO MODULE			
		COMBO MODULE 24X GBASE W/ BEZEL	6M.AAMVN.001
		OPTICAL BRACKET	33.AAMVN.002
		COMBO BEZEL G-BASE	42.AAMVN.011
		DVD COMBO,PHILIPS SCB5265 ,GB,LF	KO.02403.007
		DVD/CDRW COMBO 24X DRIVE PANASONIC UJDA-770	KO.02406.013
DVD-RW DRIVE			

Category	No.	Part Name and Description	Acer Part No.
		DVD-RW MODULE 24X DUAL GBASE W/BEZEL	6M.AAMVN.002
		OPTICAL BRACKET	33.AAMVN.002
		DVD DUAL BEZEL G-BASE	42.AAMVN.012
		DVD-RW DRIVE 8X DUAL PHILIPS SDVD841 W/O BEZEL	KU.00809.004
		DVD-RW DRIVE 8X DUAL TOSHIBA TS-L532U W/O BEZEL	KU.00801.005
		DVD-RW MODULE 24X SUPER MULTI GBASE W/BEZEL	6M.AAMVN.003
		OPTICAL BRACKET	33.AAMVN.002
		SUPER MULTI BEZEL GBASE	42.AAMVN.013
		DVD-RW DRIVE 8X SUPER MULTI TOSHIBA TS-L632D W/O BEZEL	KU.00801.014
		DVD-RW DRIVE 8X S-MUTI PANASONIC UJ-850 W/O BEZEL	KU.00807.025
		DVD-RW MODULE SUPER MULTI SLOT-IN PIONEER GBASE W/BEZEL	6M.AAMVN.004
		OPTICAL BRACKET	33.AAMVN.002
		SUPER MULIA SLOT-IN BEZEL PIONEER	42.AAMVN.014
		DVD-RW DRIVE 8X SUPER MULTI SLOT IN PIONEER DVR-K06RS W/O BEZEL	KU.00805.027
		DVD-RW MODULE SUPER MULTI SLO-IN KME GBASE W/BEZEL	6M.AAMVN.005
		OPTICAL BRACKET	33.AAMVN.002
		SUPER MULTI SLOT-IN BEZEL KME	42.AAMVN.015
		DVD-RW DRIVE 8X SUPER MULTI SLOT IN PANASONIC UJ-855 W/O BEZEL	KU.00807.029

Category	No.	Part Name and Description	Acer Part No.
		DVD-RW MODULE HD DVD ROM GBASE W/BEZEL	6M.AAMVN.006
		OPTICAL BRACKET	33.AAMVN.002
		HD DVD BEZEL	42.AAMVN.016
		HD 1X DVD ROM TOSHIBA TS-L802A LF W/O BEZEL	KV.01H01.001
FAN			
	FAN	FAN	23.AAMVN.003
HDD/HARD DISK DRIVER			
		HDD 100G 5400RPM SEAGATE ST9100824A	KH.10001.007
		HDD 100G 5400RPM TOSHIBA MK1032GAX	KH.10004.002
		HDD100G 5400RPM HGST MORAGA+ HTS541010G9AT00 ROHS F/W:A60A	KH.10007.004
		HDD 100G 5400RPM SAMSUNG HM100JC	KH.1000B.002
		HDD 120G 5400RPM SEAGATE ST9120821A LF MERCURY 2 FW:3.06	KH.12001.024
		HDD 120GB TOSHIBA 2.5 IN. 5400RPM MK1234GAX LF TAURUS FW:AC001A	KH.12004.002
		HDD 120G 5400RPM SAMSUNG HM120JC M60 LF FW: YL100-08	KH.1200B.001
		HDD 160G 5400RPM SEAGATE ST9160821A VENUS LF FW:3.ALA	KH.16001.020
		HDD INSULATOR	42.AAMVN.005
		HDD 80G SEAGATE 5.4K SATA ST98823AS MERCURY 2 FW:3.06 LF	KH.08001.023
		HDD 80G HGST 5.4K SATA 1.5G NCQ MORAGA+HTS541080G9SA00,C60D	KH.08007.015

Category	No.	Part Name and Description	Acer Part No.
		HDD 80G 5400RPM SATA TOSHIBA ARES-B_S MK8032GSX F/W AS111G	KH.08004.005
		HDD 80G SAMSUNG 5400RPM SATA HM080II M60S LF FW:YC200-08	KH.0800B.005
		HDD 100G HGST SATA 1.5G NCQMORAGA+HTS541010G9SA00 FW:S60D	KH.10007.005
		HDD 100G SEAGATE 5.4K SATA ST9100824AS MERCURY 2 FW:3.06 LF	KH.10001.008
		HDD 100G TOSHIBA SATA 5.4K ARES-B_S MK1032GSX F/W AS021G	KH.10004.003
		HDD 100G 5400RPM SATA SAMSUNG HM100JI M60S LF FW:YH100-10	KH.1000B.003
		HDD 120G SEAGATE 5.4K SATA ST9120821AS LF MERCURY 2 FW:3.06	KH.12001.025
		HDD 120G TOSHIBA 5.4K SATA1.5G W/NCQ MK1234GSX LF TAURUS FW:AH001A	KH.12004.003
		HDD 120G 5400RPM SATA SAMSUNG HM120JI M60S LF FW: YF100-10	KH.1200B.002
		HDD INSULATOR	42.AAMVN.005
HEATSINK			
		CPU HEATSINK	34.AAMVN.001
		FINGER HEATSINK	34.AAMVN.002
KEYBOARD			
		AS9800 KEYBOARD DARFON US INTERNATIONAL	KB.AAK07.001
		AS9800 KEYBOARD DARFON CHINESE	KB.AAK07.002
		AS9800 KEYBOARD DARFON SPANISH	KB.AAK07.003
		AS9800 KEYBOARD DARFON THAI	KB.AAK07.004
		AS9800 KEYBOARD DARFON BRAZILIAN PROTUGESE	KB.AAK07.005

Category	No.	Part Name and Description	Acer Part No.
		AS9800 KEYBOARD DARFON KOREA	KB.AAK07.006
		AS9800 KEYBOARD DARFON UK	KB.AAK07.007
		AS9800 KEYBOARD DARFON GERMAN	KB.AAK07.008
		AS9800 KEYBOARD DARFON ITALIAN	KB.AAK07.009
		AS9800 KEYBOARD DARFON FRENCH	KB.AAK07.010
		AS9800 KEYBOARD DARFON SWISS/ G	KB.AAK07.011
		AS9800 KEYBOARD DARFON PORTUGUESE	KB.AAK07.012
		AS9800 KEYBOARD DARFON ARABIC	KB.AAK07.013
		AS9800 KEYBOARD DARFON BELGIUM	KB.AAK07.014
		AS9800 KEYBOARD DARFON SWEDEN	KB.AAK07.015
		AS9800 KEYBOARD DARFON CZECH	KB.AAK07.016
		AS9800 KEYBOARD DARFON HUNGAIAN	KB.AAK07.017
		AS9800 KEYBOARD DARFON NORWAY	KB.AAK07.018
		AS9800 KEYBOARD DARFON DANISH	KB.AAK07.019
		AS9800 KEYBOARD DARFON TURKISH	KB.AAK07.020
		AS9800 KEYBOARD DARFON CANADIAN FRENCH	KB.AAK07.021
		AS9800 KEYBOARD DARFON GREEK	KB.AAK07.023
		AS9800 KEYBOARD DARFON HEBREW	KB.AAK07.024
		AS9800 KEYBOARD DARFON RUSSIAN	KB.AAK07.025
		AS9800 KEYBOARD DARFON SLOVENIA (SLO)	KB.AAK07.026
		AS9800 KEYBOARD DARFON CROATIA (CR)	KB.AAK07.027
LCD			
		LCD MODULE 19.1" WXGA+ SAMSUNG NON-GLARE	6M.AAMVN.011
		INVERTER BOARD 19IN. TDK XAD369NR 4 LAMPS	19.AAMVN.001
		LCD CABLE 19.1IN. SAMSUNG W/CCD CABLE	50.AAMVN.011



Category	No.	Part Name and Description	Acer Part No.
		WIRELESS ANTENNA FOR 19.1IN.	25.AAMVN.001
		CCD CAMERA 1.3M LOGITECH	56.AAMVN.002
		LCD BEZEL 19" W/LOGO	60.AAMVN.006
		LCD COVER W/LOGO	60.AAMVN.007
		LCD BARCKET L W/HINGE 19.1IN. SAMSUNG	33.AAMVN.003
		LCD BARCKET R W/HINGE 19.1IN. SAMSUNG	33.AAMVN.004
		LCD 19IN. WXGA+ SAMSUNG LTN190- M2-000 8MS 300NITS NON-GLARE	LK.19106.002
		LCD MODULE 19.1" WXGA+ CMO NON-GLARE	6M.AAMVN.012
		INVERTER BOARD 19IN. TDK XAD369NR 4 LAMPS	19.AAMVN.001

Category	No.	Part Name and Description	Acer Part No.
		LCD CABLE 19.1IN. CMO W/CCD CABLE	50.AAMVN.012
		WIRELESS ANTENNA FOR 19.1IN.	25.AAMVN.001
		CCD CAMERA 1.3M LOGITECH	56.AAMVN.002
		LCD BEZEL 19" W/LOGO	60.AAMVN.006
		LCD COVER W/LOGO	60.AAMVN.007
		LCD BARCKET L W/HINGE 19.1IN. CMO	33.AAMVN.005
		LCD BARCKET R W/HINGE 19.1IN. CMO	33.AAMVN.006
		LCD 19WXGA+ CMO M190A1-L01 8MS 300NITS NON-GLARE	LK.1910D.003
		LCD MODULE 19.1" WXGA+ SAMSUNG GLARE	6M.AAMVN.013
		INVERTER BOARD 19IN. TDK XAD369NR 4 LAMPS	19.AAMVN.001
		LCD CABLE 19.1IN. SAMSUNG W/CCD CABLE	50.AAMVN.011
		WIRELESS ANTENNA FOR 19.1IN.	25.AAMVN.001
		CCD CAMERA 1.3M LOGITECH	56.AAMVN.002
		LCD BEZEL 19" W/LOGO	60.AAMVN.006
		LCD COVER W/LOGO	60.AAMVN.007
		LCD BARCKET L W/HINGE 19.1IN. SAMSUNG	33.AAMVN.003
		LCD BARCKET R W/HINGE 19.1IN. SAMSUNG	33.AAMVN.004
		LCD 19IN. WXGA+ SAMSUNG LTM190-M2-L01-G 8MS 300NITS GLARE TYPE	LK.19006.007
		LCD MODULE 19.1" WXGA+ CMO GLARE	6M.AAMVN.014
		INVERTER BOARD 19IN. TDK XAD369NR 4 LAMPS	19.AAMVN.001
		LCD CABLE 19.1IN. CMO W/CCD CABLE	50.AAMVN.012
		WIRELESS ANTENNA FOR 19.1IN.	25.AAMVN.001
		CCD CAMERA 1.3M LOGITECH	56.AAMVN.002
		LCD BEZEL 19" W/LOGO	60.AAMVN.006
		LCD COVER W/LOGO	60.AAMVN.007
		LCD BARCKET L W/HINGE 19.1IN. CMO	33.AAMVN.005
		LCD BARCKET R W/HINGE 19.1IN. CMO	33.AAMVN.006
		LCD 19IN. WXGA+ CMO M190A1-L03 8MS 300NITS GLARE TYPE	LK.1900D.004
		LCD MODULE 20.1" WXGA+ QDI NON-GLARE	6M.AAMVN.021
		INVERTER BOARD 20IN. TDK XAD313NR 6 LAMPS	19.AAMVN.002

Category	No.	Part Name and Description	Acer Part No.
		LCD CABLE 20.1IN. QDI W/CCD CABLE	50.AAMVN.021
		WIRELESS ANTENNA FOR 20.1IN.	25.AAMVN.002
		CCD CAMERA 1.3M LOGITECH	56.AAMVN.002
		LCD BEZEL 20" W/LOGO	60.AAMVN.008
		LCD COVER W/LOGO	60.AAMVN.007
		LCD BARCKET L W/HINGE 20.1IN.	33.AAMVN.007
		LCD BARCKET R W/HINGE 20.1IN.	33.AAMVN.008
		LCD 20.1IN. WSXGA+ QDI QD20AL0101 8MS 300NITS NON-GLARE	LK.20109.001
		LCD MODULE 20.1" WXGA+ AUO NON-GLARE	6M.AAMVN.022
		INVERTER BOARD 20IN. TDK XAD313NR 6 LAMPS	19.AAMVN.002
		LCD CABLE 20.1IN. AUO W/CCD CABLE	50.AAMVN.022
		WIRELESS ANTENNA FOR 20.1IN.	25.AAMVN.002
		CCD CAMERA 1.3M LOGITECH	56.AAMVN.002
		LCD BEZEL 20" W/LOGO	60.AAMVN.008
		LCD COVER W/LOGO	60.AAMVN.007
		LCD BARCKET L W/HINGE 20.1IN.	33.AAMVN.007
		LCD BARCKET R W/HINGE 20.1IN.	33.AAMVN.008
		LCD 20.1IN. WSXGA+ AUO M201EW01 V.0 8MS 300NITS NON-GLARE	LK.20105.002
		LCD MODULE 20.1" WXGA+ QDI GLARE	6M.AAMVN.023
		INVERTER BOARD 20IN. TDK XAD313NR 6 LAMPS	19.AAMVN.002
		LCD CABLE 20.1IN. QDI W/CCD CABLE	50.AAMVN.021
		WIRELESS ANTENNA FOR 20.1IN.	25.AAMVN.002
		CCD CAMERA 1.3M LOGITECH	56.AAMVN.002
		LCD BEZEL 20" W/LOGO	60.AAMVN.008
		LCD COVER W/LOGO	60.AAMVN.007
		LCD BARCKET L W/HINGE 20.1IN.	33.AAMVN.007
		LCD BARCKET R W/HINGE 20.1IN.	33.AAMVN.008
		LCD 20.1IN. WSXGA+ QDI QD20AL0102 8MS 300NITS GLARE TYPE	LK.20109.005
		LCD MODULE 20.1" WXGA+ AUO GLARE	6M.AAMVN.024
		INVERTER BOARD 20IN. TDK XAD313NR 6 LAMPS	19.AAMVN.002
		LCD CABLE 20.1IN. AUO W/CCD CABLE	50.AAMVN.022
		WIRELESS ANTENNA FOR 20.1IN.	25.AAMVN.002
		CCD CAMERA 1.3M LOGITECH	56.AAMVN.002

Category	No.	Part Name and Description	Acer Part No.
		LCD BEZEL 20" W/LOGO	60.AAMVN.008
		LCD COVER W/LOGO	60.AAMVN.007
		LCD BARCKET L W/HINGE 20.1IN.	33.AAMVN.007
		LCD BARCKET R W/HINGE 20.1IN.	33.AAMVN.008
		LCD 20.1IN. WSXGA+ AUO M201EW01 V.2 8MS 300NITS GLARE	LK.20105.003
MAINBOARD			
		MAINBOARD G72M/128MB SATA W/O CPU W/VGA HEATSINK & PCMCIA SLOT & RTC BATTERY	MB.AAK0B.001
		MAINBOARD G72M/128MB SATA W/O CPU W/VGA HEATSINK & PCMCIA SLOT & RTC BATTERY	MB.AAK0B.001
		MAINBOARD G72M/256MB SATA W/O CPU W/VGA HEATSINK & PCMCIA SLOT & RTC BATTERY	MB.AAK0B.002
		MAINBOARD G73M/128MB SATA W/O CPU W/VGA HEATSINK & PCMCIA SLOT & RTC BATTERY	MB.AAK0B.003
		MAINBOARD G73M/256MB SATA W/O CPU W/VGA HEATSINK & PCMCIA SLOT & RTC BATTERY	MB.AAK0B.004
		MAINBOARD G73M/256MB SATA W/O CPU W/VGA HEATSINK & PCMCIA SLOT & RTC BATTERY	MB.AAK0B.004
		MAINBOARD G73M/256MB SATA W/O CPU W/VGA HEATSINK & PCMCIA SLOT & RTC BATTERY	MB.AAK0B.004
		MAINBOARD G73M/512MB SATA W/O CPU W/VGA HEATSINK & PCMCIA SLOT & RTC BATTERY	MB.AAK0B.005
		MAINBOARD G72MV/128MB SATA W/O CPU W/VGA HEATSINK & PCMCIA SLOT & RTC BATTERY W/O RF-IN & AV-IN CONNECTOR	MB.AAK0B.006
		MAINBOARD G73M/256MB SATA W/O CPU W/VGA HEATSINK & PCMCIA SLOT & RTC BATTERY W/O RF-IN & AV-IN CONNECTOR	MB.AAK0B.007
MEMORY(DDR2 533)			
		SO-DIMM DDR2 533 256MB SAMSUNG M470T3354CZ3-CD5 LF	KN.2560B.017
		SO-DIMM DDR2 533 256M MICRON MT4HTF3264HY-53EB4	KN.25604.030

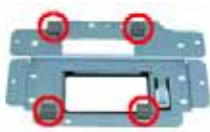
Category	No.	Part Name and Description	Acer Part No.
		SO-DIMM DDRII533 256M HYNIX HYMP532S64BP6-C4	KN.2560G.012
		SO-DIMM DDRII533 256MB NANYA NT256T64UH4A1FN-37B LF	KN.25603.029
		SO-DIMM DDRII533 512MB SAMSUNG M470T6554CZ3-CD500 LF	KN.5120B.015
		SO-DIMM DDRII533 512M HYNIX HYMP564S64BP6-C4	KN.5120G.013
		SO-DIMM DDRII533 512MB NANYA NT512T64UH8A1FN-37B LF	KN.51203.023
		SO-DIMM DDRII533 512M ELPIDA GU33512AGEPN612C	KN.51209.005
		SO-DIMM DDRII533 1GB MANYA NT1GT64UH8A0BN-37B LF	KN.1GB03.006
		SO-DIMM DDRII533 1GB INFINEON HYS64T128021HDL-3.7-B	KN.1GB02.030
		SO-DIMM DDRII533 1GB SAMSUNG M470T2953CZ3-CD5 LF	KN.1GB0B.004
MEMORY(DDR2 667)			
		SO-DIMM DDRII667 256MB SAMSUNG M470T3354CZ3-CE6 LF	KN.2560B.018
		SO-DIMM DDRII667 256MB NANYA NT256T64UH4A1FN-3C LF	KN.25603.027
		SO-DIMM DDRII667 256MB INFINEON HYS64T32000HDL-3S-B (.09U/G)	KN.25602.032
		SO-DIMM DDRII667 256MB HYNIX HYMP532S64BP6-Y5 LF (.09UM)	KN.2560G.013
		SO-DIMM DDRII667 512MB SAMSUNG M470T6554CZ3-CE6 LF	KN.5120B.018
		SO-DIMM DDRII667 512MB NANYA NT512T64UH8A1FN-3C LF	KN.51203.025
		SO-DIMM DDRII667 512MB INFINEON HYS64T64020HDL-3S-B (.09U/G)	KN.51202.035
		SO-DIMM DDRII667 512MB HYNIX HYMP564S64BP6-Y5 LF (.09UM)	KN.5120G.014
		SO-DIMM DDRII667 512MB ELPIDA GU33512AJEPN612C LF	KN.51209.006
		SO-DIMM DDRII667 1GB SAMSUNG M470T2953CZ3-CE6	KN.1GB0B.005
		SO-DIMM DDRII667 1GB INFINEON HYS64T128021HDL-3S-B (.09U/G)	KN.1GB02.029
		SO-DIMM DDRII667 1GB NANYA NT1GT64U8HA0BN-3C LF	KN.1GB03.009
		SO-DIMM DDRII667 1GB ELPIDA GU331G0AJEPN6E2C LF	KN.1GB09.005
MISCELLANEOUS			
		LCD RUBBER CUSHION	47.AAMVN.001

Category	No.	Part Name and Description	Acer Part No.
		SPEAKER BUMPER	47.AAMVN.002
		TOUCHPAD BRACKET GASKET (Highlighted with red circles)	47.AAMVN.003
		EXTERNAL ANTENNA SET	25.AAMVN.004
ACCESSORY			
		ACER BLUETOOTH VOIP CARD PHONE KIT V2.2 W/CD & MANUAL	LC.BTH01.008
		REMOTE CONTROLLER RC-802 48KEY	RT.8020A.001
		MCERC-200 REMOTE CONTROLLER	LC.MCE05.001
		MCEIR-210 RECEIVER	LC.MCE05.002
		MCEBS-220 IR BLASTER	LC.MCE05.003
ACCESSORY(BOARD)			
		TV TUNER M103 S/W MPEG (HYBRID)	55.AAMVN.006
		TV TUNER M104 HW MPEG (ANALOG)	55.AAMVN.007
		TV TUNER M115 ADT (HYBRID)	55.AAMVN.008
ACCESSORY(CABLE)			
		CABLE AV-IN	50.AAMVN.008
		CABLE PAL/SECAM	50.AAMVN.009
MISCELLANEOUS			
		NTSC ADAPTER	25.AAMVN.003
MICROPHONE			
		MICROPHONE	23.AAMVN.001
SPEAKER			
		SPEAKER SET	23.AAMVN.002
SCERW			
		SCREW	86.AAMVN.001
		SCREW	86.AAMVN.002

Category	No.	Part Name and Description	Acer Part No.
		SCREW	86.AAMVN.003
		SCREW	86.AAMVN.004
		SCREW	86.AAMVN.005
		SCREW	86.AAMVN.006
		SCREW	86.AAMVN.007
		SCREW	86.AAMVN.008
		SCREW	86.AAMVN.009
		SCREW	86.AAMVN.010
		SCREW	86.AAMVN.011
		SCREW	86.AAMVN.012

