



**Copyright © 1998 Acer Incorporated
All Rights Reserved — Printed in Taiwan**

TravelMate 310 Series Notebook Computer User's Guide
Part No. 49.42B01.011
Original Issue: June 1998

Changes may be made periodically to the information in this publication. Such changes will be incorporated in new editions of this manual.

Record the serial number, purchase date, and model number in the space provided below. The serial number and model number are recorded on the label affixed to the case. All correspondence concerning your unit should include the serial number, model number, and date of purchase.

No part of this publication may be reproduced, stored in a retrieval system, or transmitted, in any form or by any means, electronic, mechanical, photocopy, recording, or otherwise, without the prior written permission of Acer Incorporated.

TravelMate Notebook Computer

Model _____ Serial No. _____ Purchase Date _____

TravelMate is a trademark and a product of Acer Inc., developed with Texas Instruments Inc. All other trademarks and registered trademarks are the property of their respective companies. Microsoft, MS-DOS, and Windows are registered trademarks of Microsoft Corporation.

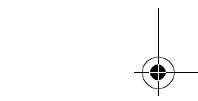
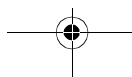
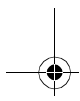
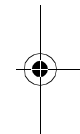
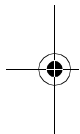

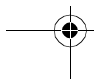
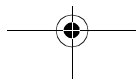
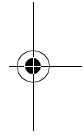
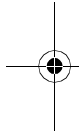
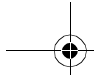

Table of Contents

Notices	v
Preface	xiii
Connecting the Notebook	xiv
Getting Help Online	xvi
Support Information	xvii
Care and Maintenance	xviii
Chapter 1 Getting Familiar with your Computer	1
Features	2
Display	4
Indicators and Microphone	6
Keyboard	8
Touchpad	15
Storage	17
Ports	19
Audio	26
Securing your Computer	28
Chapter 2 Operating on Battery Power	31
Battery Pack	32
Power Management	39
Chapter 3 Peripherals and Options	45
External Monitor	46
External Keyboard	47
External Keypad	48
External Pointing Device	49
Printer	51
Audio Devices	52
PC Cards	53
External PCMCIA CD-ROM (optional)	54
USB Devices	55
Miscellaneous Options	56
Key Component Upgrades	59
Chapter 4 Moving with your Computer	61
Disconnecting from the Desktop	62
Moving Around	63
Taking the Computer Home	64
Traveling with the Computer	66



Table of Contents

Traveling Internationally with the Computer 67

Chapter 5 Software 69

 System Software 70

 PhDISK 71

 Notebook Manager 72

 Setup Utility 81

Chapter 6 Troubleshooting 95

 Frequently-Asked Questions 96

 Error Messages 100

Appendix A Specifications 103

Index 107

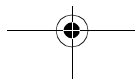
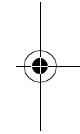
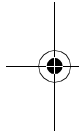

Notices

Acer Year 2000 Compliance Statement

The Travelmate 310 series notebook computer is Year 2000-compliant and carries the "NSTL Hardware Tested Year 2000 Compliant" logo. The Travelmate 310 series notebook computer has been tested both by Acer's internal test labs and NSTL's YMARK2000 certification test. These tests certify that the Travelmate 310 series notebook computer will successfully make the year 2000 transition.



For more details, check the Acer Year 2000 Resource Center at <http://www.acer.com/year2000>



Notices

FCC Notice

This device has been tested and found to comply with the limits for a Class B digital device pursuant to Part 15 of the FCC Rules. These limits are designed to provide reasonable protection against harmful interference in a residential installation. This device generates, uses, and can radiate radio frequency energy and, if not installed and used in accordance with the instructions, may cause harmful interference to radio communications.

However, there is no guarantee that interference will not occur in a particular installation. If this device does cause harmful interference to radio or television reception, which can be determined by turning the device off and on, the user is encouraged to try to correct the interference by one or more of the following measures:

1. Reorient or relocate the receiving antenna
2. Increase the separation between the device and receiver
3. Connect the device into an outlet on a circuit different from that to which the receiver is connected
4. Consult the dealer or an experienced radio/television technician for help

Notice: Shield Cables

All connections to other computing devices must be made using shielded cables to maintain compliance with FCC regulations.

Notice: Peripheral Devices

Only peripherals (input/output devices, terminals, printers, etc.) certified to comply with the Class B limits may be attached to this equipment. Operation with non-certified peripherals is likely to result in interference to radio and TV reception.

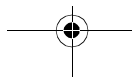

Notices

Caution

Changes or modifications not expressly approved by the manufacturer could void the user's authority, which is granted by the Federal Communications Commission, to operate this computer.

Use Conditions

This part complies with Part 15 of the FCC Rules. Operation is subject to the following two conditions: (1) this device may not cause harmful interference, and (2) this device must accept any interference received, including interference that may cause undesired operation.

Notice: Canadian Users

This Class B digital apparatus meets all requirements of the Canadian Interference-Causing Equipment Regulations.

Remarque à l'intention des utilisateurs canadiens

Cet appareil numérique de la classe B respecte toutes les exigences du Règlement sur le matériel brouilleur du Canada.



Notices

Important Safety Instructions

- 1.** Read these instructions carefully. Save these instructions for future reference.
- 2.** Follow all warnings and instructions marked on the product.
- 3.** Unplug this product from the wall outlet before cleaning. Do not use liquid cleaners or aerosol cleaners. Use a damp cloth for cleaning.
- 4.** Do not use this product near water.
- 5.** Do not place this product on an unstable cart, stand, or table. The product may fall, causing serious damage to the product.
- 6.** Slots and openings in the cabinet and the back or bottom are provided for ventilation; to ensure reliable operation of the product and to protect it from overheating, these openings must not be blocked or covered. The openings should never be blocked by placing the product on a bed, sofa, rug, or other similar surface. This product should never be placed near or over a radiator or heat register, or in a built-in installation unless proper ventilation is provided.
- 7.** This product should be operated from the type of power indicated on the marking label. If you are not sure of the type of power available, consult your dealer or local power company.
- 8.** Do not allow anything to rest on the power cord. Do not locate this product where persons will walk on the cord.
- 9.** If an extension cord is used with this product, make sure that the total ampere rating of the equipment plugged into the extension cord does not exceed the extension cord ampere rating. Also, make sure that the total rating of all products plugged into the wall outlet does not exceed the fuse rating.

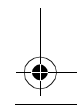
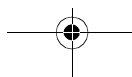
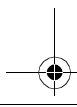
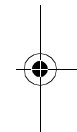
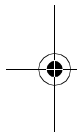

Notices

- 10.** Never push objects of any kind into this product through cabinet slots as they may touch dangerous voltage points or short out parts that could result in a fire or electric shock. Never spill liquid of any kind on the product.
- 11.** Do not attempt to service this product yourself, as opening or removing covers may expose you to dangerous voltage points or other risks. Refer all servicing to qualified service personnel.
- 12.** Unplug this product from the wall outlet and refer servicing to qualified service personnel under the following conditions:
 - a.** When the power cord or plug is damaged or frayed
 - b.** If liquid has been spilled into the product
 - c.** If the product has been exposed to rain or water
 - d.** If the product does not operate normally when the operating instructions are followed. Adjust only those controls that are covered by the operating instructions since improper adjustment of other controls may result in damage and will often require extensive work by a qualified technician to restore the product to normal condition.
 - e.** If the product has been dropped or the cabinet has been damaged
 - f.** If the product exhibits a distinct change in performance, indicating a need for service.
- 13.** Replace the battery with the same type as the product's battery we recommend. Use of another battery may present a risk of fire or explosion. Refer battery replacement to a qualified serviceman.
- 14.** Warning! Batteries may explode if not handled properly. Do not disassemble or dispose of them in fire. Keep them away from children and dispose of used batteries promptly.

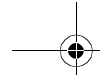

Notices

15. Use only the proper type of power supply cord set (provided in your accessories box) for this unit. It should be a detachable type: UL listed/CSA certified, type SPT-2, rated 7A 125V minimum, VDE approved or its equivalent. Maximum length is 15 feet (4.6 meters).

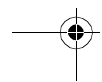
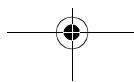
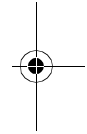
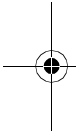

Notices

Lithium Battery Statement

CAUTION

Danger of explosion if battery is incorrectly replaced. Replace only with the same or equivalent type recommended by the manufacturer. Discard used batteries according to the manufacturer's instructions.

ADVARSEL!

Lithiumbatteri - Eksplosjonsfare ved feilagtig håndtering. Udsiftning må kun ske med batteri af samme fabrikat og type. Léver det brugte batteri tilbage til leverandøren.

ADVARSEL

Ekspløsjonsfare ved feilaktig skifte av batteri. Benytt samme batteritype eller en tilsvarende type anbefalt av apparatfabrikanten. Brukte batterier kasseres i henhold til fabrikantens instruksjoner.

VARNING

Explosionsfara vid felaktigt batteribyte. Använd samma batterityp eller en ekvivalent typ som rekommenderas av apparattillverkaren. Kassera använt batteri enligt fabrikantens instruktion.

VAROITUS

Päristo voi räjähtää, jos se on virheellisesti asennettu. Vaihda paristo ainoastaan laitevalmistajan suositteluun tyypin. Hävitä käytetty paristo valmistajan ohjeiden mukaisesti.

VORSICHT!

Explosionsgefahr bei unsachgemäßen Austausch der Batterie Ersatz nur durch denselben oder einem vom Hersteller empfohlenem ähnlichen Typ. Entsorgung gebrauchter Batterien nach Angaben des Herstellers.

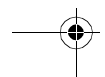
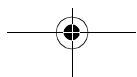
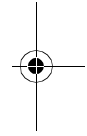
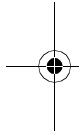
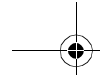

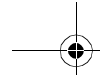

Preface

This manual describes features of the TravelMate 310 Series notebook computers. The TravelMate series computers incorporate such features as CardBus, 16-bit stereo audio, Fast Infrared, internal pointing device, and Universal Serial Bus.

This manual should answer most of the questions you have about the day-to-day operation of your TravelMate notebook computer.

Use the Just for Starters... instructions that came with your computer to get your computer running for the first time.

You should also take advantage of the online help files that are available with almost all of the programs shipped with your computer.

We hope you enjoy your TravelMate computer. With proper care, your computer will provide you with years of productive service.

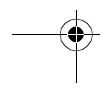
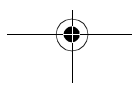
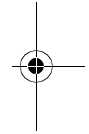
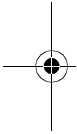

Preface

Connecting the Notebook

Connecting the computer is easy; just follow these steps:



Note: Make sure the cover latch is unlock before inserting the battery pack otherwise you won't be able to insert the battery pack.

1. Slide out the battery compartment cover (a) and align the battery's clasp to the cover and slide it down until the battery is properly seated (b). Slide the battery with the compartment cover back into the computer (c) and then lock the battery in place (d).

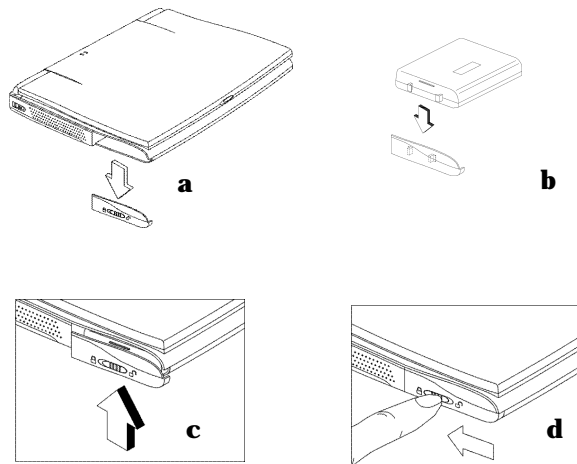

Note: When using a battery pack for the first time, fully recharge the battery, then disconnect the adapter to use up the battery before recharging again. You only need to do this once with a new battery.

Preface

2. Connect one end of the AC adapter to the DC-in port on the computer's rear panel and the other end to a properly grounded power outlet.

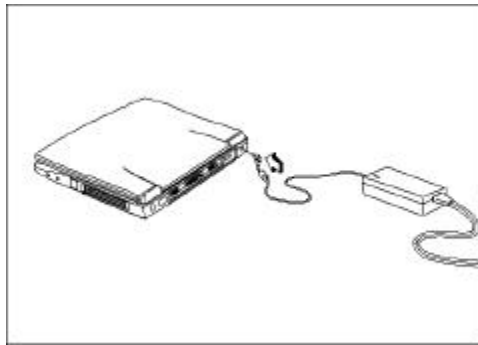

3. Open the display cover and slide the power switch towards the rear of the computer then release it to turn on the power. The POST (Power On Self-Test) routine executes and Windows begins loading.



Note: To turn off power, slide the power switch again. If you are using Windows 95 or higher version operating system, we recommend you use the Shutdown command to turn off the computer. If you turn off the computer and want to turn it on again, wait at least 2 seconds before powering up.

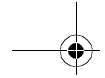

Preface

Getting Help Online

This user's guide provides clear and concise information about the notebook, so read it thoroughly. To provide you with help when traveling, the notebook also comes with a comprehensive online help.

Accessing Online Help

Follow these steps to access the online documentation:

1. Press the Windows logo button or Click on the Start button.
2. Select Programs.
3. Click on TravelMate Online.

The online help is easy to navigate with hypertext and hypergraphics. Clear illustrations help describe notebook operation as well.

Getting Online

If you are connected to the Internet and have World Wide Web access, visit our home page (<http://www.acer.com/>) and get the latest information about our products.

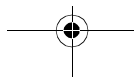

Preface

Support Information

Your notebook is backed by an International Traveler's Warranty (ITW) that gives you security and peace of mind when traveling. Our worldwide network of service centers are there to give you a helping hand.

An ITW passport comes with your computer. This passport contains all you need to know about the ITW program. A list of available, authorized service centers are in this handy booklet. Read this passport thoroughly.



Note: Always have your ITW passport on hand, especially when you travel to receive the benefits from our support centers. Place your proof-of-purchase in the flap located inside the front cover of the ITW passport.

If the country you are traveling in does not have an Acer-authorized ITW service site, you can still get in contact with our offices worldwide.

For technical assistance and support in the United States and Canada, you can call 1-800-816-2237. You can also contact the local dealer or distributor in the country you are traveling in for assistance.

To view support information, follow these steps:

1. Click on Start, Settings..., Control Panel.
2. Double-click on System.
3. Click on Support Information.



Note: If you are connected to the Internet and have World Wide Web access, visit our home page (<http://www.acer.com/>) and get an updated list of our worldwide offices, as well as information about our products.

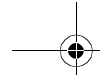

Preface

Care and Maintenance

Taking Care of Your Computer

Your computer will serve you well if you take care of it.

- Do not expose the notebook to direct sunlight. Do not place near sources of heat, such as a radiator.
- Do not expose to temperatures below 0°C (32°F) or above 50°C (122°F).
- Do not subject the notebook to magnetic fields.
- Do not expose the notebook to rain or moisture.
- Do not spill water or any liquid on the notebook.
- Do not subject the computer to heavy shock and vibration.
- Do not expose the notebook to dust and dirt.
- Never place objects on top of the notebook to avoid damaging the notebook.
- Never place the notebook on uneven surfaces.

Taking Care of your AC Adapter

Here are some ways to take care of your AC adapter:

- Do not connect the adapter to any other device.
- Do not step on the power cord or place heavy objects on top of it. Carefully route the power cord and any cables away from personal traffic.
- When unplugging the power cord, do not pull on the cord itself but pull on the plug.

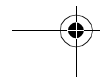
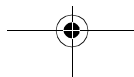

Preface

- The total ampere ratings of the equipment plugged in should not exceed the ampere rating of the cord if you are using an extension cord. Also, the total current rating of all equipment plugged into a single wall outlet should not exceed the fuse rating.

Taking Care of your Battery Pack

Here are some ways to take care of your battery pack:

- Use only batteries of the same kind as replacements. Turn the power off before removing or replacing batteries.
- Do not tamper with batteries. Keep them away from children.
- Dispose of used batteries according to local regulations. Recycle if at all possible.

Cleaning and Servicing

When cleaning the notebook, follow these steps:

- 1.** Power off the notebook and remove the battery pack.
- 2.** Disconnect the AC adapter.
- 3.** Use a soft cloth moistened with water. Do not use liquid or aerosol cleaners.

Contact your dealer or see your service technician if any of the following occurs:

- Notebook has been dropped or the body has been damaged.
- Liquid has been spilled into the product.
- The notebook does not operate normally.

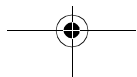
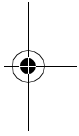
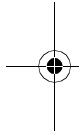

Getting Familiar with your Computer

This computer combines high-performance, versatility, power management features and multimedia capabilities with a unique style and ergonomic design. Work with unmatched productivity and reliability with your new power computing partner.

This chapter gives an in-depth "tour" of the computer's many features.

Contents

Features	2
Display	4
Indicators and Microphone	6
Keyboard	8
Special Keys	8
Lock Keys	8
Embedded Keypad	9
Windows Keys	10
Hot Keys	11
Keyboard Ergonomics	14
Touchpad	15
Touchpad Basics	15
Storage	17
Hard Disk	17
External Drive	17
Connecting an External Floppy Drive	18
Ports	19
Rear Ports	19
Fast Infrared	20
Universal Serial Bus	21
Right Ports	22
Fax/Data Modem	23
PC Card Slots	23
Audio	26
Securing your Computer	28
Security Notch	28
Passwords	28

Features

Features

This computer was designed with the user in mind. Here are just a few of its many features:

Performance

- Intel Pentium® processor with MMX™ technology
- 64-bit main memory and external (L2) cache memory
- Large LCD display and PCI local bus video with 128-bit graphics acceleration
- External 3.5-inch floppy drive
- External CD-ROM drive (optional)
- High-capacity, enhanced-IDE hard disk
- Lithium-Ion battery pack
- Heuristic power management system with standby and hibernation power saving modes

Multimedia

- 16-bit high-fidelity stereo audio with 3-D sound
- Built-in speaker
- Built-in microphone

Connectivity

- High-speed fax/data modem port
- Fast infrared wireless communication
- USB (Universal Serial Bus) port

Human-centric Design and Ergonomics

- Lightweight and slim
- Sleek, smooth and stylish design

Features

- Wide and curved palm rest
- Ergonomically-centered touchpad pointing device

Expansion

- CardBus PC card (formerly PCMCIA) slots (two type II/I or one type III) with ZV (Zoomed Video) port support
- Upgradeable memory and hard disk

Display

Display

The graphics display offers excellent viewing, display quality and desktop performance graphics. The computer supports two different display configurations — Supertwist Nematic (STN) or Thin-Film Transistor (TFT).

Video Performance

PCI local bus video with 128-bit graphics acceleration and 1.1MB Extended Data Out (EDO) video RAM boost video performance.

Simultaneous Display

This computer supports simultaneous LCD and CRT display by connecting an external monitor when giving presentations. Simultaneous display allows you to control the presentation from your computer and at the same time face your audience. You can even connect other output display devices such as LCD projection panels for large-audience presentations.

Power Management

The power management system incorporates an "automatic LCD dim" feature that automatically decides the best settings for your display and at the same time conserve power. See "Power Management" on page 39 for more information on power management.

Opening and Closing the Display

To open the display, slide the display lid latch to the left and lift up the lid. Then tilt it to a comfortable viewing position. The computer employs a microswitch that turns off the display (and enters standby mode) to conserve power when

Display

you close the display cover, and turns it back on when you open the display cover.



Note: *If an external monitor is connected, the computer turns off the display (but does not enter standby mode) when you close the display cover.*

To close the display cover, fold it down gently until the display cover latch clicks into place.



Caution: *To avoid damaging the display, do not slam it when closing. Do not place any object on top of the computer when the display is closed.*



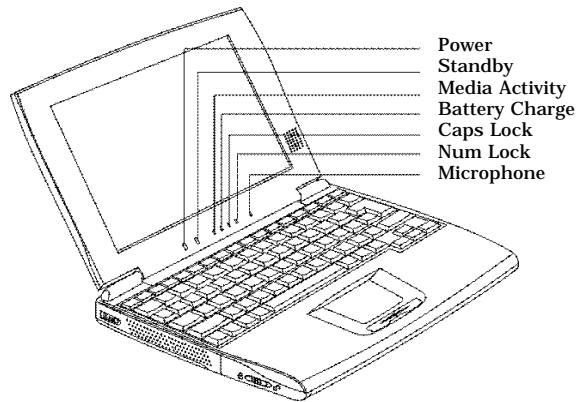

Indicators and Microphone

Indicators and Microphone



The computer has six easy-to-read status indicators (LEDs) and a microphone near the display cover.



The Power and Standby indicators are visible even when you close the display cover so you can see the status of the computer while the cover is closed. The LED panel also has an internal microphone for multimedia purposes.

Icon	Function	Description
	Power	Lights when the computer is on.
	Standby	Lights when the computer enters Standby mode.
	Media Activity	Lights when the hard disk is active.
	Battery Charge	Lights when the battery is being charged.

Indicators and Microphone

Icon	Function	Description
	Caps Lock	Lights when Caps Lock is activated
	Num Lock	Lights when Numeric Lock is activated
	Microphone	Use for sound input

Keyboard

Keyboard

The keyboard includes an embedded keypad, separate cursor keys, three Windows keys and twelve function keys.

Special Keys

Lock Keys

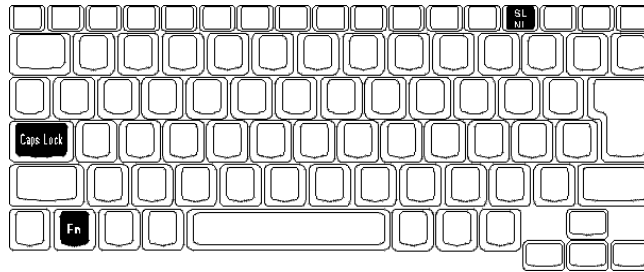

The keyboard has three lock keys which you can toggle on and off.

Lock Key	Description
Caps Lock	When Caps Lock is on, all alphabetic characters typed are in uppercase.
Num Lock (Fn-SL)	When Num Lock is on, the embedded keypad is in numeric mode. The keys function as a calculator (complete with arithmetic operators +, -, *, and /). Use this mode when you need to do a lot of numeric data entry. A better solution would be to connect an external keypad.
Scroll Lock	When Scroll Lock is on, the screen moves one line up or down when you press ↑ or ↓ respectively. Scroll lock does not work with some applications.

Keyboard

Embedded Keypad

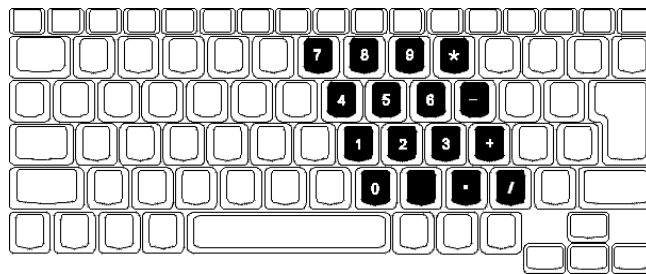

The embedded keypad functions like a desktop numeric keypad. It is indicated by small characters located on the upper right corner of the keycaps. To simplify the keyboard legend, cursor-control key symbols are not printed on the keys.

Desired Access	Num Lock On	Num Lock Off
Number keys on embedded keypad	Type numbers in a normal manner.	
Cursor-control keys on embedded keypad	Hold Shift while using cursor-control keys.	Hold Fn while using cursor-control keys.
Main keyboard keys	Hold Fn while typing letters on embedded keypad.	Type the letters in a normal manner.



Note: If an external keyboard or keypad is connected to the computer, the numlock feature automatically shifts from the internal keyboard to the external keyboard or keypad.

Keyboard

Windows Keys

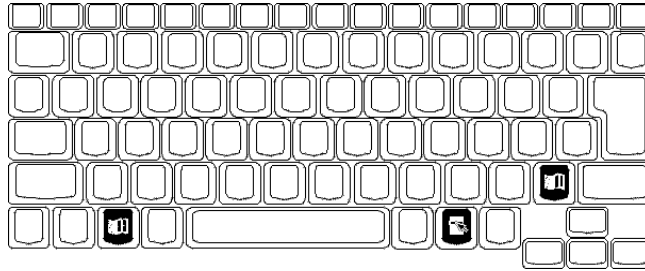

The keyboard has three keys that perform Windows specific functions.



Key	Description
Windows logo key	Start button. Combinations with this key perform special functions. Below are a few examples: <ul style="list-style-type: none"> ⊞ + Tab (Activate next Taskbar button) ⊞ + E (Explore My Computer) ⊞ + F (Find Document) ⊞ + M (Minimize All) Shift + ⊞ + M (Undo Minimize All) ⊞ + R (Display Run dialog box)
Application key	Opens the application's context menu (same as right-click).

Keyboard

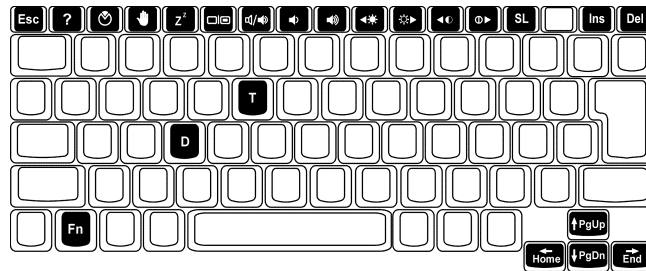







Hot Keys



The computer employs hot keys or key combinations to access most of the computer's controls like screen contrast and brightness, volume output and the BIOS setup utility.

Hot Key	Icon	Function	Description
Fn-F1	?	Help	Displays a list of the hotkeys and their functions.
Fn-F2		Notebook Manager	Access the notebook configuration utility. See "Notebook Manager" on page 72.
Fn-F3		Standby	Puts the computer in Standby mode. Press any key to return. See "Standby mode" on page 40 to know more about Standby mode.
Fn-F4		Hibernation	Puts the computer in Hibernation mode (Save to Disk). Press the power switch to resume. See "Hibernation mode" on page 41 to know more about Hibernation mode

Keyboard

Hot Key	Icon	Function	Description
Fn-F5		Display toggle	Switches display output between the display screen, external monitor (if connected) and both the display screen and external monitor.
Fn-F6		Speaker on/off	Turns the speaker on and off; mutes the sound.
Fn-F7		Speaker volume down	Decreases the speaker's volume level.
Fn-F8		Speaker volume up	Increases the speaker's volume level.
Fn-F9		Brightness down	Decreases the screen brightness.
Fn-F10		Brightness up	Increases the screen brightness.
Fn-F11		Contrast down	Decreases the screen contrast (available only for models with STN displays).
Fn-F12		Contrast up	Increases the screen contrast (available only for models with STN displays).
Fn-↑	PgUp	Page Up	Scrolls the screen one page up.
Fn-↓	PgDn	Page Down	Scrolls the screen one page down.

Keyboard

Hot Key	Icon	Function	Description
Fn-→	End	End	Go to the end of the screen.
Fn-←	Home	Home	Go to the beginning of the screen.
Fn-D		Screen blank	Turns the display screen backlight off to save power. Press any key to return.
Fn-T		Touchpad on/off ¹	Turns the internal touchpad on and off. See "Touchpad" on page 15.
Fn-SL		Num Lock	When Num Lock is on, the embedded keypad is in numeric mode.
Fn-Ins		Print Screen	Prints the information currently displayed on screen.
Fn-Del		System Request	Software specific function.

¹Fn-T only works when no external PS/2 mouse or external serial mouse is connected to the computer.

Activating Hot Keys

When activating hot keys, press and hold the first key Fn before pressing the other key in the hot key combination.

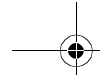

Keyboard

Keyboard Ergonomics

Located below the keyboard, the wide and curved palm rest gives you a place to rest your hands while you type.

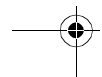
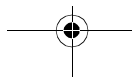
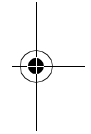
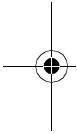
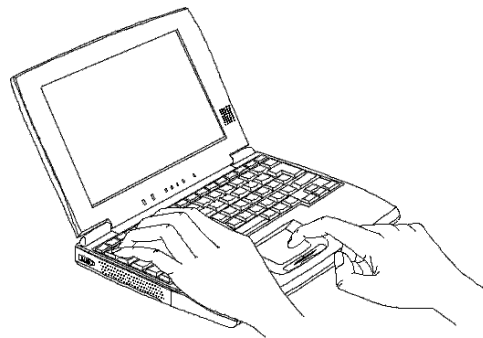

Touchpad

Touchpad

The built-in touchpad is a PS/2-compatible pointing device that senses movement on its surface. This means the cursor responds as you move your finger on the surface of the touchpad. The central location on the palm rest provides ample comfort and support.

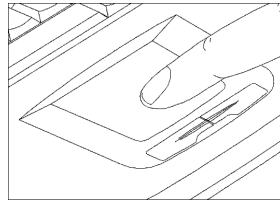

Note: Connecting an external PS/2 mouse to the computer will automatically disable the touchpad.

Touchpad Basics

The following items teach you how to use the touchpad:

- Move your finger across the touchpad to move the cursor.
- Press the left and right buttons located on the edge of the touchpad to do selection and execution functions. These two buttons are similar to the left and right buttons on a mouse. Tapping on the touchpad produces similar results.

Touchpad

Function	Left Button	Right Button	Tap
Execution	Click twice quickly		Tap twice (at the same speed as double-clicking the mouse button)
Selection	Click once		Tap once
Drag	Click and hold, then use finger to drag the cursor on the touchpad		Tap twice (at the same speed as double-clicking the mouse button) and hold finger to the touchpad on the second tap to drag the cursor
Access context menu		Click once	



Note: Keep your fingers dry and clean when using the touchpad. Also keep the touchpad dry and clean. The touchpad is sensitive to finger movements. Hence, the lighter the touch, the better the response. Tapping too hard will not increase the touchpad's responsiveness.

Storage

Storage

This computer comes with a high-capacity Enhanced-IDE hard disk. You can also connect an external 3.5-inch, 1.44MB floppy drive to your computer.

Hard Disk

The removable hard disk module can be upgraded when you need more storage space. See "Hard Disk Upgrade" on page 60.

External Drive

The computer can share the parallel port with both a printer and an external floppy drive. It can automatically detect whether a printing device or a floppy drive has been inserted. You can connect these two devices together using an optional parallel cable (See "Parallel Cable" on page 57). External 3.5-inch floppy drives come with a capacity of 720KB, 1.2MB, or 1.44MB.

You can also connect an external PCMCIA CD-ROM drive to the computer. See "External PCMCIA CD-ROM (optional)" on page 54 for more information on connecting an external CD-ROM.

Storage

Connecting an External Floppy Drive

Connect the larger end of the floppy drive cable to the parallel port and the other end to the connector on the external floppy drive.

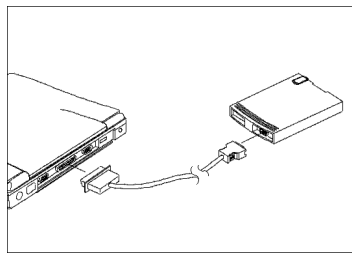

Note: The external floppy drive is hot-pluggable. You do not need to turn off the computer to connect and use the floppy drive.

Ports

Ports

Ports allow you to connect peripheral devices to your computer as you would with a desktop PC.



Note: See Chapter 3 on how to connect external devices to the computer.



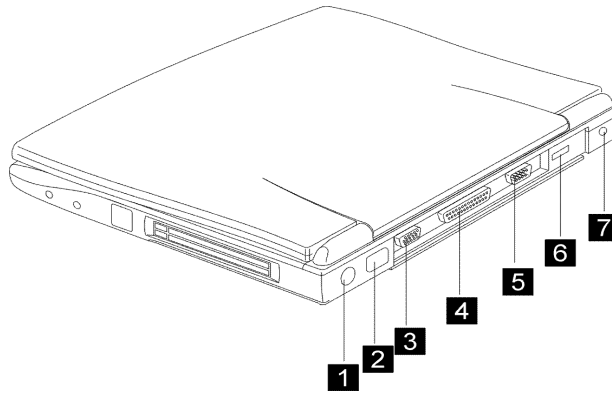

Rear Ports



Caution: When opening the rear port cover, carefully slide it under the computer using both hands.

#	Icon	Port	Connects to...
1		PS/2 Port	PS/2-compatible devices (e.g., PS/2 keyboard, keypad, mouse)
2		FIR Port	Infrared devices (e.g., infrared printer, IR-aware computers)

Ports

#	Icon	Port	Connects to...
3		Serial port	Serial devices (e.g., serial mouse)
4		Parallel port	Parallel devices (e.g., parallel printer)
5		External monitor port	Display monitors (up to 1024x768 resolution, 64K-colors)
6		USB Port	USB devices
7		DC-in jack	AC adapter and power outlet

Fast Infrared

The computer's fast infrared (FIR) port allows you to do wireless data transfer with other IR-aware computers and peripherals such as infrared printers. The infrared port can transfer data at speeds of up to four megabits per second (Mbps) at a distance of up to one meter.

Ports

To use FIR, position two IR-aware devices such that their IR ports are no more than one meter apart and offset no more than 15 degrees.

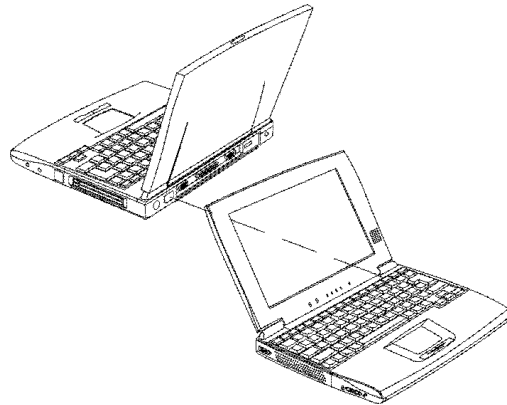

When the two computers are in position, simply begin the data transfer as you normally would. See your file transfer software for details.





Universal Serial Bus

The Universal Serial Bus (USB) port allows you to connect USB peripherals without occupying system resources.

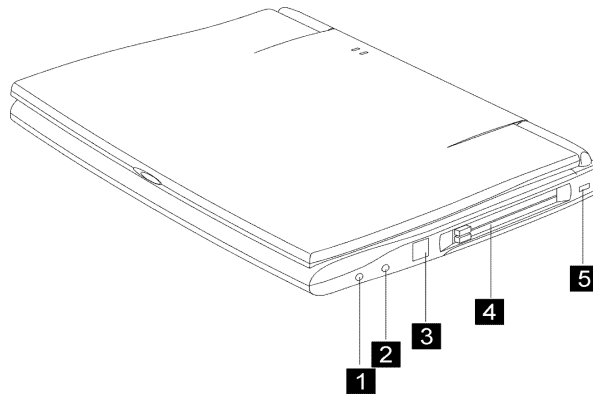
Ports

Right Ports



#	Icon	Port	Connects to...
1		Microphone-in jack	Audio line-in devices (e.g., external 3.5mm minijack condenser microphone, audio CD player, stereo walkman)
2		Speaker-out jack	Speakers or headphones
3		Modem jack	Phone line
4		PC Card slots	16-bit PC Cards and 32-bit CardBus PC Cards (Only the lower PC Card socket supports ZV PC Cards)
5		Security Lock	a Kensington-compatible key-based computer security lock

Ports

Fax/Data Modem

The computer has a built-in fax/data modem.



Caution: This modem port is not compatible with digital phone lines. Plugging this modem into a digital phone line will damage the modem.

To use the fax/data modem port, connect a phone cable from the modem port to a telephone jack.

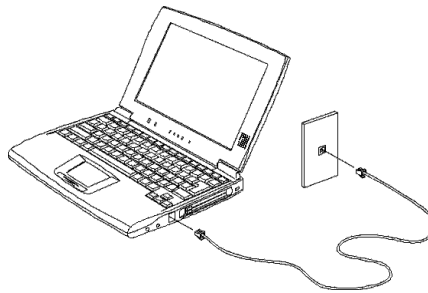

Start your communications software program. See your communications manual for instructions.

PC Card Slots

There are two type II/I or one type III CardBus PC Card slots found on the right panel of the computer. These slots accept credit-card-sized cards that enhance the usability and expandability of the computer.

PC Cards (formerly PCMCIA) are add-on cards for portable computers, giving you expansion possibilities long afforded by desktop PCs. Popular type II cards include flash memory, SRAM, fax/data modem, LAN and SCSI cards. Common type III cards are 1.8-inch ATA drives and cellular modems. CardBus improves on the 16-bit PC card technology by expanding the bandwidth to 32 bits.

Ports

ZV (Zoomed Video) port support allows your computer to support hardware MPEG in the form of a ZV PC card. Only the lower PC Card socket supports ZV PC cards.



Note: Refer to your card's manual for details on how to install and use the card and its functions.

Inserting a Card

Insert the card into the desired slot and make the proper connections (e.g., network cable), if necessary. See your card manual for details.

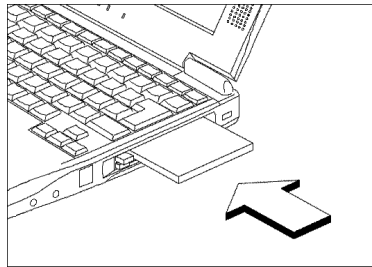

For type III cards, insert card into the lower slot.

Ejecting a Card

Before ejecting a PC card:

- Exit the application using the card.
- Left-click on the PC card icon on the taskbar and stop the card operation.

Ports

Then press the slot eject button to eject the card.

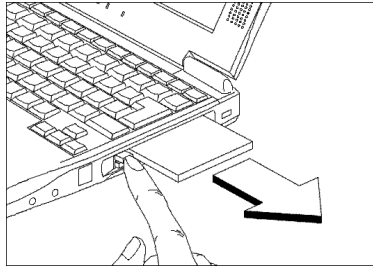

Audio

Audio

The standard computer configuration includes 16-bit high-fidelity stereo audio with further enhancements that include 3D sound for true audio immersion. The speaker, positioned beside the display, directs sound towards you which allows for excellent sound output.

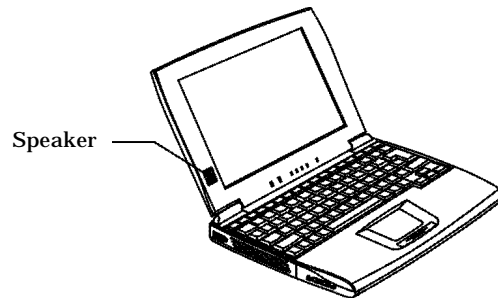

For TFT Display Type Model

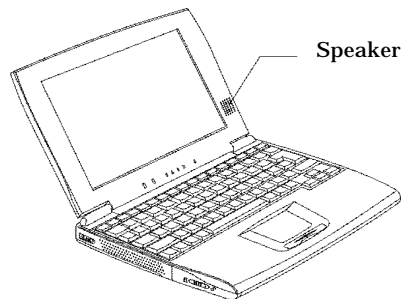

For STN Display Type Model

Besides the built-in speaker, there is an audio port on the right panel of the computer. See "Audio Devices" on page 52 for more information on connecting external audio devices.

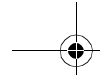

Audio

Controlling Volume

The volume of the computer is easily controlled using hotkeys. Press Fn-F7 to decrease the speaker's volume level or press Fn-F8 to increase the volume level. See "Hot Keys" on page 11 for more information.

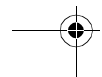
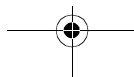
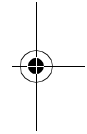
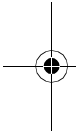

Securing your Computer

Securing your Computer

Security features include hardware and software locks — a security notch and a two-level password scheme.

Security Notch

A security notch located on the right panel of the computer lets you connect a Kensington-compatible key-based computer security lock.

Wrap a computer security lock cable around an immovable object such as a table or locked drawer handle. Insert the lock into the notch and turn the key to secure the lock.

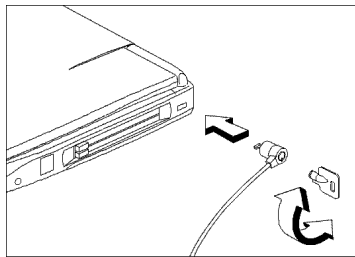

Passwords

A two-level password scheme protects your computer from unauthorized access. When set, no one can access the computer without entering the correct password. See “Security” on page 88 for more information on setting and removing a password.

There are two types of passwords you can set:

- Supervisor Password** secures your computer against unauthorized use and prevents unauthorized access to certain sections of the Setup Utility. Once set, you must key-in this password to set certain parameters in the Setup Utility. See “Setup Utility” on page 81 for details.

Securing your Computer

- User Password secures your computer against unauthorized use.



Important: Do not forget your password! If you forget your password, you need to contact your dealer.

Note: You must set the supervisor password before you can set the user password.

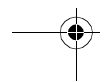
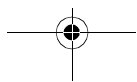
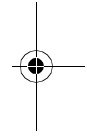
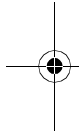
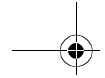

2

Operating on Battery Power

The computer operates on AC or battery power. This chapter contains the information you need to know to operate the computer on battery power. It also includes information on how your computer manages and saves power.

Contents

Battery Pack	32
Battery Pack Characteristics	32
Installing and Removing the Battery Pack	33
Charging the Battery	34
Charging Modes	34
Checking the Battery Level	35
Using the Windows Battery Meter	35
Optimizing Battery Life	36
Battery-low Warning	37
Power Management	39
Power Management Modes	39
Display Standby Mode	39
Hard Disk Standby Mode	40
Peripheral Standby Modes	40
Standby mode	40
Hibernation mode	41
Advanced Power Management	43

Battery Pack

Battery Pack

The computer uses a battery pack that gives you long use between charges.

Battery Pack Characteristics

The battery pack has the following characteristics:

Employs Current Battery Technology Standards

The computer uses a Lithium-Ion battery pack. This battery type does not have the memory effect problem of Nickel Cadmium (NiCd). Li-Ion batteries consistently provide the longest battery life, best-suited for road warriors.

Battery-low Warning

When the battery charge level becomes low, the computer gives off warning beeps and the status indicator flashes at regular intervals. This tells the user that the battery power is critically low. You can correct this situation by recharging the battery pack.

Whenever possible, use the AC adapter. The battery will come in handy when you travel or during a power failure. It is advisable to have an extra fully-charged battery pack available as backup.



Note: When using a battery pack for the first time, fully recharge the battery, then disconnect the adapter to use up the battery before recharging again. You only need to do this once with a new battery or with a battery that's been stored without being used for a long time. If the computer is to be stored for more than two weeks, we suggest that you remove the battery pack. Battery power (from a fully charged battery pack) depletes in roughly a day with the computer in Standby mode, or a month in Hibernation mode or when the power is off.

Battery Pack



Warning: Do not expose battery packs to temperatures below 0°C (32°F) or above 60°C (140°F). This may adversely affect the battery pack.

Installing and Removing the Battery Pack

Before removing the battery pack, make sure that you have an AC adapter connected to the computer; otherwise turn off the computer.

Follow these steps:

1. Slide down the cover.

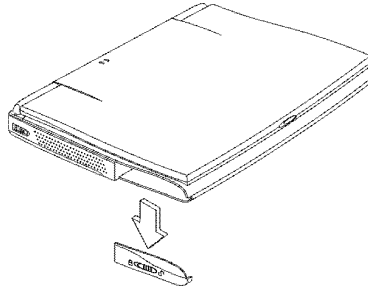

2. Attach the battery to the cover. Align the battery's clasp to the cover and slide it down until the battery is properly seated.

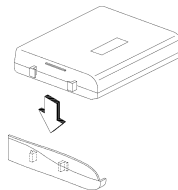

Note: Make sure the cover latch is unlock before inserting the battery pack otherwise you won't be able to insert the battery pack.

Battery Pack

3. Insert the battery into the computer.

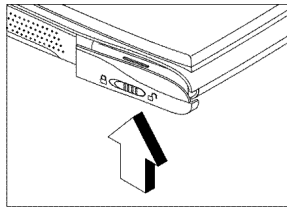

4. Push the cover upward and then lock the cover.

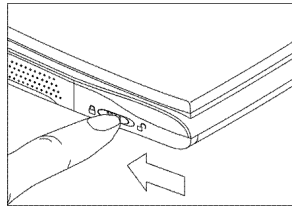

To remove the battery pack, unlock the cover latch and then slide down the battery compartment cover; pull out the battery pack.

Charging the Battery

To charge the battery, place the battery pack inside the battery compartment and plug the AC adapter into the computer and an electrical outlet.

Charging Modes

The adapter has three charging modes:

- Rapid mode

The computer uses rapid charging when power is turned off and a powered AC adapter is connected to it. In rapid

Battery Pack

mode, a fully depleted battery gets fully charged in approximately two hours.

Charge-in-use mode

When the computer is in use with the AC adapter plugged in, the computer also charges the battery pack if installed. This mode will take longer to fully charge a battery than rapid mode. In charge-in-use mode, a fully depleted battery gets fully charged in approximately six to eight hours.

Trickle mode

When the battery is fully charged, the adapter changes to trickle mode to maintain the battery charge level. This prevents the battery from draining while the computer is in use.



Note: We suggest that you charge the battery pack before retiring for the day, letting it charge overnight before traveling. This ensures a fully charged battery for use the next day.

Checking the Battery Level

The computer features battery-low warning signals that are both audible and visible. When the battery pack is low, the computer emits warning beeps and the battery indicator flashes at regular intervals. Also, you can check the battery charge level using the Windows battery gauge.

Using the Windows Battery Meter

The Windows battery meter indicates the present battery level. Simply rest your cursor on the battery gauge (or AC plug) icon on the taskbar to see the present charge level of your battery.

Battery Pack

Optimizing Battery Life

This section helps you get the most out of battery operation. Optimizing battery life prolongs the charge/recharge cycle and improves recharge efficiency. Follow these suggestions to optimize and maximize battery power:

- Purchase an extra battery pack.
- Use the PHDISK utility to reserve hard disk space for the Hibernation function. See “PhDISK” on page 71.
- Use the AC adapter whenever possible so that the battery is reserved for on-the-go computing.
- Keep the battery pack in the computer powered by the AC adapter. The constant trickle charge maintains the battery level to eliminate the battery self-discharge effect. The charge-in-use function also charges the battery pack.
- Disable the parallel and serial ports if no devices are connected to these ports. You can do this through the Setup Utility. See “Advanced” on page 86.
- Eject the PC card from the card slot when not in use, since the PC card draws extra power.
- Store the battery pack in a cool, dry place. The recommended storage temperature for battery packs ranges from 10 to 30 degrees C. The higher the storage temperature, the faster the battery pack self-discharges.
- The batteries can be recharged about 300 times when used as directed. Excess recharging decreases battery life.
- Take care of your battery pack and AC adapter. See “Care and Maintenance” on page xviii of the Preface.

Battery Pack

Battery-low Warning

You never have to worry about battery power as long as you are using the AC adapter. However, when you operate the computer on battery power, pay extra attention to the warning beeps and the power indicator on the display panel.

The following signals indicate a battery-low condition:

- The buzzer generates four short beeps every minute, if you enabled the Battery-low Warning Beep parameter in Setup
- The power indicator flashes at regular intervals until battery power is depleted

When you receive a battery-low warning, you have around three minutes to save your work. If you do not connect the AC adapter within this period, the computer enters Hibernation mode if the Battery Low Suspend parameter in Setup is enabled and the following conditions exist:

- The Hibernation file created by PHDISK is present and valid. See "PhDISK" on page 71.
- There is enough battery power left to save system information onto the hard disk.

Otherwise, the computer enters Standby mode.



Warning: Connect the AC adapter to the computer as soon as possible. Data is lost when computer power is cut off during Standby mode.

Battery Pack

The following table shows the recommended course of action to take when you encounter a battery-low condition:

Situation	Recommended Action
AC adapter and power outlet available	<ol style="list-style-type: none"> 1. Connect the AC adapter to the computer. 2. Save all necessary files. 3. Resume work. Power off the computer if you wish to recharge the battery rapidly.
An extra fully-charged battery pack available	<ol style="list-style-type: none"> 1. Save all necessary files. 2. Exit the application. 3. Power off the computer. 4. Replace the battery pack. 5. Power on the computer and resume work. or <ol style="list-style-type: none"> 1. Save all necessary files. 2. Enter Hibernation mode. 3. Install the extra battery pack. 4. Resume from Hibernation mode.
AC adapter or power outlet not available	<ol style="list-style-type: none"> 1. Save all necessary files. 2. Exit the application. 3. Power off the computer. or <ol style="list-style-type: none"> 1. Save all necessary files. 2. Enter Hibernation mode.

Power Management

Power Management

This computer has a built-in power management unit that monitors system activity. System activity refers to any activity involving one or more of the following devices: keyboard, mouse, floppy drive, hard disk, peripherals connected to the serial and parallel ports, and video memory. If no activity is detected for a period of time (called an inactivity time-out), the computer stops some or all of these devices in order to conserve energy.



Note: We recommend you enable power management to prolong your battery life.

Power Management Modes

Display Standby Mode

Screen activity is determined by the keyboard, the built-in touchpad, and an external PS/2 pointing device. If these devices are idle for the period specified by the Display Timeout, the display shuts off until you press a key or move the touchpad or external mouse.

"Automatic Dim" Feature

The computer has a unique "automatic dim" power saving feature. When the computer is using AC power and you disconnect the AC adapter from the computer, it automatically dims the LCD backlight to save power. If you reconnect AC power to the computer, it automatically adjusts the LCD backlight to a brighter level.

Power Management

Hard Disk Standby Mode

The hard disk enters standby mode when there are no disk read/write operations within the period of time specified by the Hard Disk Timeout. In this state, the power supplied to the hard disk is reduced to a minimum. The hard disk returns to normal once the computer accesses it.

Peripheral Standby Modes

The peripheral connections in your computer also power down to save power if there is no activity within the period of time specified by Timeout values for these devices. These include audio, serial ports, floppy drive and parallel port.

Standby mode

The computer consumes very low power in Standby mode. All data remains intact in the system memory until the battery is drained.

There is one necessary condition for the computer to enter Standby mode:

- Heuristic Power Management must be set to [ENABLED]

There are five ways to enter Standby mode:

- Pressing the Standby hot key Fn-F3
- Allowing the waiting time determined by the Standby Timeout to elapse without any system activity
- Closing the display cover
- Allowing the computer to enter Hibernation mode when battery is low, but
 - the Hibernation file is invalid or not present, or
- Allowing the operating system power saving modes to invoke it

Power Management



Note: If the computer beeps but does not enter Standby mode after pressing the Standby hot key, it means the operating system will not allow the computer to enter the power saving mode.

The following signals indicate that the computer is in Standby mode:

- The buzzer beeps
- The Standby indicator lights



Warning: Unstored data is lost when you turn off the computer power in Standby mode (by holding the power switch for more than 4 seconds) or when the battery is drained.

To leave Standby mode and return to normal mode:

- Press any key
- Move the active pointing device (internal or external, PS/2 or serial)
- Allow the Resume Timer to be matched
- Open the display cover
- Receive an incoming PC card modem event when the Resume on Modem Ring is enabled

Hibernation mode

In Hibernation mode, all power shuts off (the computer does not consume any power). The computer saves all system information onto the hard disk before it enters Hibernation mode. Once you turn on the power, the computer restores this information and resumes where you left off.

Power Management

There are two necessary conditions for the computer to enter Hibernation mode:

- The Hibernation file created by PHDISK must be present and valid. See “PhDISK” on page 71
- Heuristic Power Management must be set to [ENABLED]

In this situation, there are four ways to enter Hibernation mode:

- Pressing the Hibernation hot key Fn-F4
- Allowing the Hibernation Timeout to elapse without any system activity
- Experiencing a battery low condition for about a minute. With the Battery Low Suspend parameter in Setup set to [ENABLED]
- Allowing the operating system power saving modes to invoke it



Note: *If the computer beeps but does not enter Hibernation mode after pressing the Hibernation hot key, it means the operating system will not allow the computer to enter the power saving mode.*

To exit Hibernation mode, press the power switch. The computer also resumes from Hibernation mode if the Resume Timer is set and matched.



Warning: *Do not change any devices (such as add memory or swap hard disks) when the computer is in Hibernation mode.*

Power Management

Advanced Power Management

This computer supports the APM standard designed to further reduce power consumption. APM is a power-management approach defined jointly by Microsoft and Intel. An increasing number of software applications support APM to take advantage of power saving features and allow greater system availability without degrading performance.

For more information about APM under Windows 95 or Windows 98, refer to your Windows 95 or 98 user's manual.



Note: *If you enable Heuristic Power Management in Setup without APM installed and enabled, the system time and date do not display the correct settings after the computer returns to normal operation from Standby or Hibernation mode. To update the time and date, reboot the computer. APM should be enabled to avoid this problem. Advanced Power Management greatly prolongs battery life. Use APM whenever possible.*

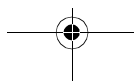
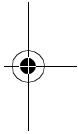
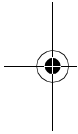

3

Peripherals and Options

Your computer offers expansion capabilities with its built-in ports and connectors. This chapter describes how to connect peripherals and hardware options that help you use your computer with ease. When connecting peripherals, read the manual included with the peripheral for operating instructions.

You can also add more memory or upgrade your hard disk when you need to in order to keep your computer in step with the latest technology. You can purchase most of these and other options directly from Acer.

Contents

External Monitor	46
External Keyboard	47
External Keypad	48
External Pointing Device	49
External PS/2 Mouse	49
External Serial Mouse	50
Printer	51
Audio Devices	52
PC Cards	53
External PCMCIA CD-ROM (optional)	54
USB Devices	55
Miscellaneous Options	56
Additional Power Packs	56
Battery Pack	56
AC Adapter	56
Cables	56
PS/2 Y-Bridge Cable	56
Parallel Cable	57
File Transfer Cable	58
Key Component Upgrades	59
Memory Upgrade	59
Memory Configurations	59
Hard Disk Upgrade	60

External Monitor

External Monitor

To show graphical effects on a larger display, connect an external monitor to the CRT port. Read the monitor manual for additional instructions.

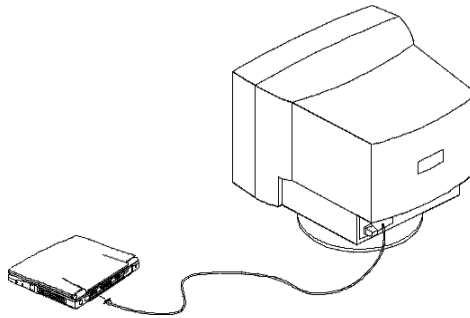

Note: If an external monitor is not connected, closing the display cover puts the computer into standby mode.

External Keyboard

External Keyboard

This computer has a keyboard with full-sized keys and an embedded keypad. If you feel more comfortable using a desktop keyboard, you can install a PS/2-compatible external keyboard.

To connect an external keyboard, plug the external keyboard into the PS/2 connector.

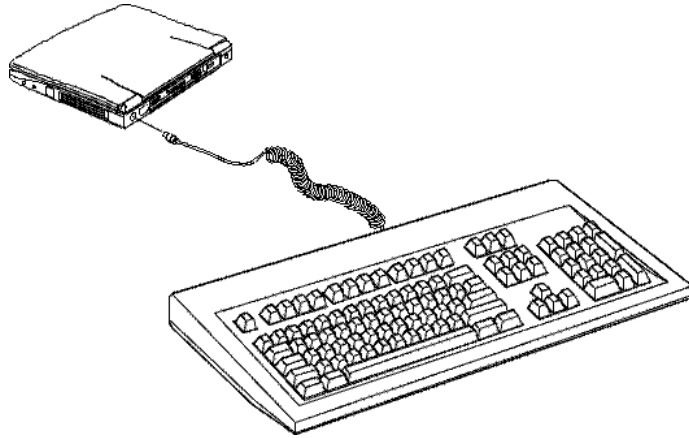

External Keypad

External Keypad

You can also use a 17-key numeric keypad for number-sensitive data entry applications. To connect the keypad, plug in the keypad connector to the PS/2 port.

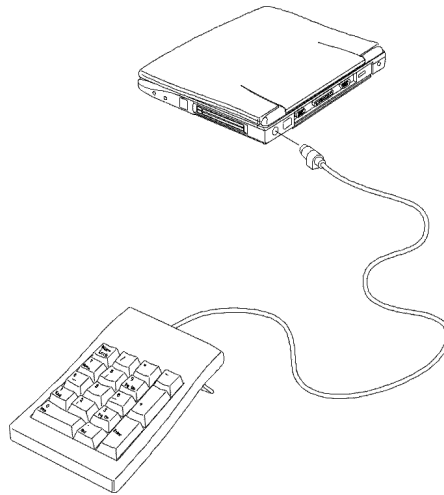

External Pointing Device

External Pointing Device

This computer accepts either a PS/2-compatible or serial mouse or similar pointing device.

External PS/2 Mouse

The built-in touchpad works alternately with an external PS/2 mouse which is hot-pluggable. To use a PS/2-compatible mouse, simply plug it into the PS/2 port.

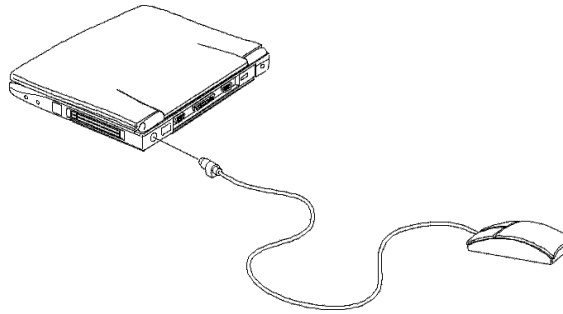

Note: The touchpad will be automatically disabled when using an external PS/2.

External Pointing Device

External Serial Mouse

If you use a serial mouse, plug it into the serial port.

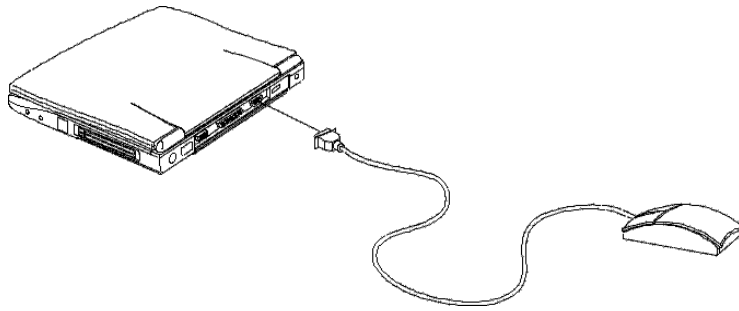

To enable the serial mouse, use the Add New Hardware tool in the Windows Control Panel.

Printer

Printer

This computer supports both serial and parallel printers. For a serial printer, plug the printer cable into a serial port. For a parallel printer, plug the printer cable into the parallel port. See your printer manual for operating instructions.

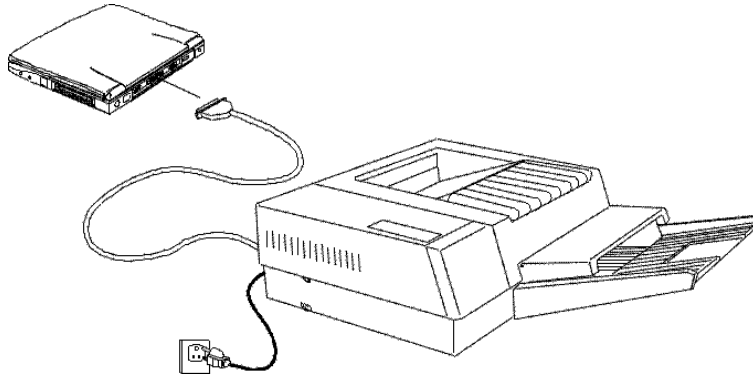

Note: If the printer does not function, enter *Setup* and verify that the parallel port is enabled. See “Advanced” on page 86 for assistance.

Audio Devices

Audio Devices

Audio devices are easy to connect with the audio ports accessible from the right side of the computer. You can plug in an external microphone or audio line-in device to the microphone-in jack. Amplified speakers or headphones connect to the speaker-out jack .

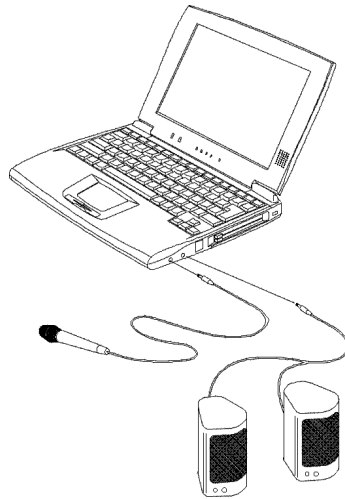

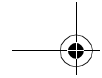

PC Cards

PC Cards

The computer has two CardBus PC card slots that accommodate two type I/II or one type III PC card(s). Please consult your dealer for PC card options available that you can purchase for your computer.

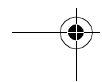
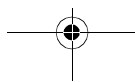
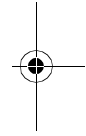
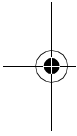

External PCMCIA CD-ROM (optional)

External PCMCIA CD-ROM (optional)

You can also connect an external CD-ROM device using a PC Card.

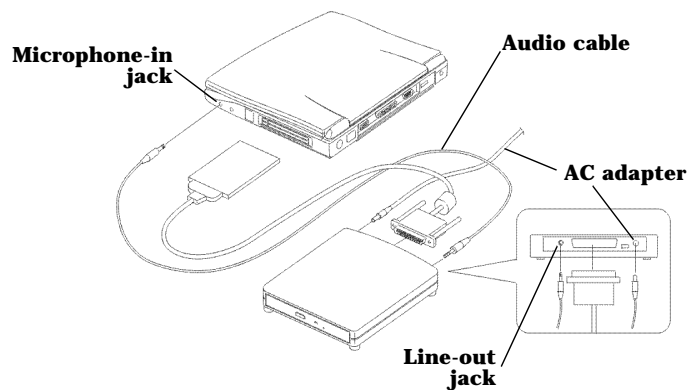

To connect an external CD-ROM drive:

1. Turn on your computer.
2. Plug the external CD-ROM's power adapter into an electrical outlet and turn the external CD-ROM on.
3. Insert the external CD-ROM PC Card into the PC Card slot. The computer will automatically detect the PC Card.
4. Insert one end of the audio cable into the external CD-ROM and the other end into the microphone-in jack of the computer

or

Insert an external speaker into the line-out jack of the external CD-ROM drive.



Note: When you connect the audio to the computer, you have to activate the sound by unchecking the mute function or by increasing the volume control in Windows 95/98.

USB Devices

If you want to listen to audio CDs from the external CD-ROM drive, we advise you to use amplified external speakers for better quality sound.

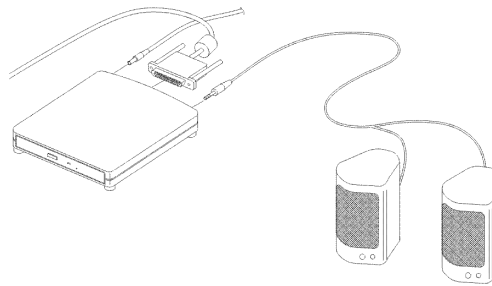

For more information about the external CD-ROM, please refer to its user's manual.

USB Devices

The computer has a USB (Universal Serial Bus) port that allows you to connect peripherals without occupying too many resources. Common USB devices include the mouse and keyboard.

Most USB devices also include a built-in USB port connector which allows you to daisy-chain other USB devices.

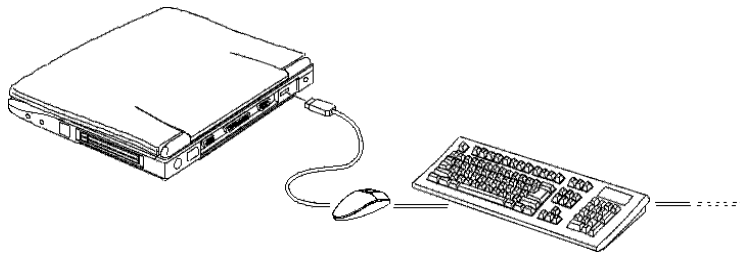

Miscellaneous Options

Miscellaneous Options

Additional Power Packs

You can order spare batteries and AC adapters.

Battery Pack

It is good practice to have a spare battery around, especially when you travel. The Li-Ion batteries, coupled with power management features, supply you with more power on-the-go.

AC Adapter

The compact AC adapter charges your battery pack and supplies power to your computer. You can order a spare AC adapter so you do not need to carry it from the office to your home or destination.

Cables

PS/2 Y-Bridge Cable

The PS/2 Y-bridge cable allows you to connect two PS/2 devices, mouse and keyboard, to your computer simultaneously.



Note: The keyboard must be connected to the connector marked keyboard and the mouse must be connected to the connector marked mouse.

Miscellaneous Options

Connect the single connector end of the Y-bridge cable to the computer's PS/2 port and the double connector ends to the two PS/2 devices.

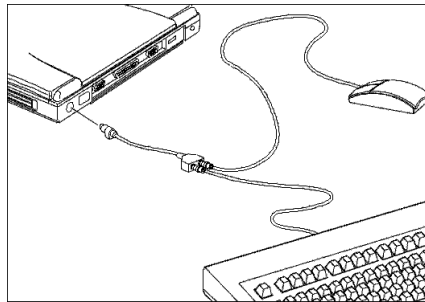

Parallel Cable

The Parallel cable allows you to connect a printer and an external floppy drive to your computer simultaneously. However, you can only use one device at a time.

Connect the single connector end of the parallel cable to the computer's parallel port and the double connector ends to the two devices.

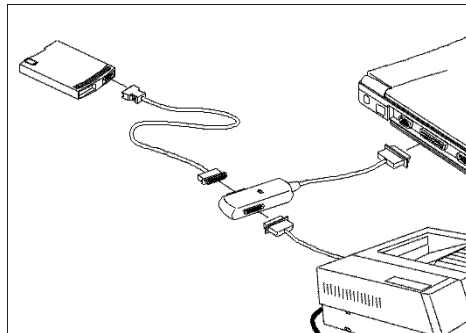

Miscellaneous Options

File Transfer Cable

Besides using the infrared port, you can also transfer files between computers using a file transfer cable. Connect the file transfer cable between the parallel ports of the two computers and use your file transfer utility to perform the transfer.

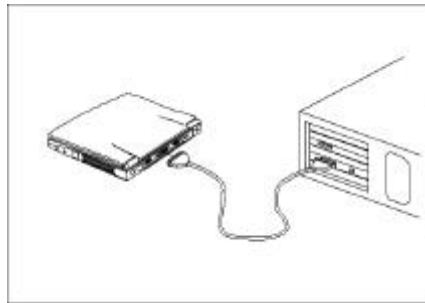

Key Component Upgrades

Key Component Upgrades

The computer delivers superior power and performance. However, some users and the applications they use may demand more. This computer allows you to upgrade key components when you need increased performance.



Note: Contact your authorized dealer if you decide to perform a key component upgrade.

Memory Upgrade

Memory is upgradeable from 16 to 80MB, employing 16-/32-/64-MB soDIMMs (Small Outline Dual Inline Memory Modules).

Memory Configurations

The following table lists the possible memory configurations:



Important! This system can only support SDRAM memory type.

Slot 1	Total Memory
0 MB	16 MB
16 MB	32 MB
32 MB	48 MB
64 MB	80 MB

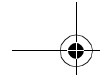

Key Component Upgrades

Hard Disk Upgrade

You can upgrade your hard disk with a higher capacity drive when you need more storage space. The computer uses a 9.5mm 2.5-inch Enhanced-IDE hard disk.



Note: Contact your authorized dealer if you decide to perform a hard disk upgrade.

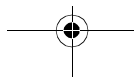
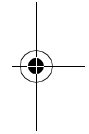
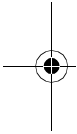

4

Moving with your Computer

This chapter gives you tips and hints on things to consider when moving around or traveling with your computer. We have arranged these according to the following situations:

- Moving Around** — when you are just moving within short distances, for example, from your office desk to a meeting room.
- Taking the Computer Home** — when you are moving from your office to your home or vice versa.
- Traveling with the Computer** — when you are moving within a larger distance, for instance, from your office building to a client's office building or traveling locally.
- Traveling Internationally with the Computer** — when you are moving from country to country.

Contents

Disconnecting from the Desktop	62
Moving Around	63
Preparing the Computer	63
What To Bring to Short Meetings	63
What To Bring to Long Meetings	63
Taking the Computer Home	64
Preparing the Computer	64
What To Bring with You	64
Special Considerations	64
Setting Up a Home Office	65
Traveling with the Computer	66
Preparing the Computer	66
What To Bring with You	66
Special Considerations	66
Traveling Internationally with the Computer	67
Preparing the Computer	67
What To Bring with You	67
Special Considerations	67

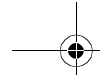

Disconnecting from the Desktop

Disconnecting from the Desktop

Follow these steps to disconnect your computer from external accessories:

- 1.** Save your work in progress.
- 2.** Shut down the operating system.
- 3.** Turn off the computer.
- 4.** Disconnect the cord from the AC adapter.
- 5.** Disconnect the keyboard, pointing device, printer, external monitor, and other external devices.
- 6.** Disconnect the Kensington lock if you are using one to secure the computer.

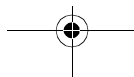
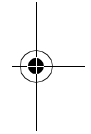
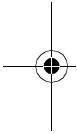

Moving Around

Moving Around

Preparing the Computer

Before moving the computer, close and latch the display cover to place it in standby mode. You can now safely take the computer anywhere you go within the building.

To bring the computer out of standby mode, open the display.

What To Bring to Short Meetings

A fully charged battery runs the computer for 2-3 hours under most circumstances. If your meeting is shorter than that, you probably do not need to bring anything with you other than the computer.

What To Bring to Long Meetings

If your meeting will last longer than 2 hours or if your battery is not fully charged, you may want to bring the AC adapter with you to plug in your computer in the meeting room.

If the meeting room does not have an electrical outlet, reduce the drain on the battery by putting the computer in standby mode. Close the display cover whenever you are not actively using the computer.

Taking the Computer Home

Taking the Computer Home

Preparing the Computer

After disconnecting the computer from your desktop, follow these steps to prepare the computer for the trip home.

1. Remove all media from the drives. Failure to remove the media can damage the drive head.
2. Pack the computer in a protective case that can prevent the computer from sliding around and cushion it if it should fall.



Caution: Avoid packing items next to the top cover of the computer. Pressure against the top cover can damage the screen

What To Bring with You

Unless you already have some items at home, bring the following items with you:

- AC adapter and power cord
- The printed user's manual
- Media bay modules (external floppy and CD-ROM drive)

Special Considerations

Follow these guidelines to protect your computer while traveling to and from work:

- Minimize the effect of temperature changes by keeping the computer with you.
- If you need to stop for an extended period of time and cannot bring the computer with you, leave the computer in the trunk of the car to avoid exposing the computer to excessive heat.

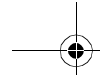

Taking the Computer Home

- ❑ Changes in temperature and humidity can cause condensation. Allow the computer to return to room temperature, and inspect the screen for condensation before turning on the computer. If the temperature change is greater than 18°F (10°C), allow the computer to come to room temperature slowly. If possible, leave the computer for 30 minutes in an environment with a temperature between outside and room temperature.

Setting Up a Home Office

If you frequently work on your computer at home, it may be worthwhile purchasing a second AC adapter for use at home. With a second AC adapter, you can avoid transporting the extra weight to and from home.

If you use your computer at home for significant periods of time, you might also want to add an external keyboard, monitor, or mouse.

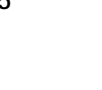
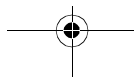
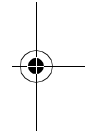
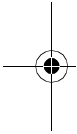

Traveling with the Computer

Traveling with the Computer

Preparing the Computer

Prepare the computer as if you were taking it home. Be sure the battery in the computer is charged. Airport security often requires you to turn on your computer when bringing it into the gate area.

What To Bring with You

Bring the following items with you:

- AC adapter
- Spare, fully-charged battery packs
- Media bay modules (external floppy and CD-ROM drive)
- Additional printer driver files if you plan to use another printer

Special Considerations

In addition to the guidelines for taking the computer home, follow these guidelines to protect your computer while traveling:

- Always take the computer as carry-on luggage.
- If possible, have the computer inspected by hand. The computer can safely pass through security X-ray machines, but never expose the computer to a metal detector.
- Avoid exposing floppy disks to hand-held metal detectors.

Traveling Internationally with the Computer

Traveling Internationally with the Computer

Preparing the Computer

Prepare the computer as you would normally prepare it for traveling.

What To Bring with You

Bring the following items with you:

- AC adapter
- Power cords that are appropriate to the country to which you are traveling
- Media bay modules
- Spare, fully-charged battery packs
- Additional printer driver files if you plan to use another printer
- Proof of purchase, in case you need to show it to Customs officials
- International Traveler's Warranty passport

Special Considerations

Follow the same special considerations as when traveling with the computer. In addition, these tips are useful when traveling internationally:

- When traveling in another country, check that the local AC voltage and the AC adapter power cord specifications are compatible. If not, purchase a power cord that is compatible with the local AC voltage. Do not use converter kits sold for appliances to power the computer.
- If you are using the modem, check if the modem and connector is compatible with the telecom system of the country you are traveling in.

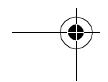
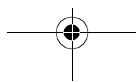
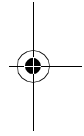
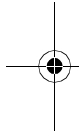
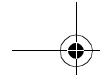

5 Software

This chapter discusses the important system utilities bundled with your computer.

Contents

System Software	70
PhDISK	71
Notebook Manager	72
Information Viewer	73
Boot Sequence	74
Password	75
Setting the Supervisor Password	76
Setting the User Password	77
Power Management	78
Display Device	79
Setup Utility	81
Navigating the Setup Utility	81
Main	82
Hard Disk 0 Submenu	84
Boot Device Priority Submenu	85
Advanced	86
Security	88
Setting a Password	89
Removing a Password	90
Power Saving	91
Exit	93

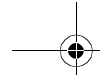

System Software

System Software

The computer comes preloaded with the following software:

- Windows 95 or later operating system
- System utilities, drivers and application software



Note: To access Windows software applications, click on the Start button and select the application folder. Then click on the application icon to run the selected application. To learn about the software and utility, make use of the online help provided by the software.

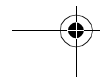
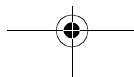
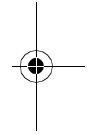
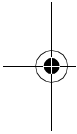

PhDISK

PhDISK

The PhDISK utility allows your computer to enter hibernation mode. Before entering hibernation mode, your computer saves all necessary information into a file or partition created by PhDISK, then shuts off power to all system components. On the next startup, the computer reloads the information from the PhDISK file or partition and resumes from where you left off.



Note: By default, this program is automatically loaded and set up on your computer so you do not need to run this program by yourself. You only need to run this if you upgrade your memory. You can find PhDISK in the `\windows\command\` directory.

The program accepts the following parameters:

Syntax

PHDISK [options]

where options:

- /CREATE (/FILE or /PARTITION) creates the hibernation file or partition
- /DELETE (/FILE or /PARTITION) deletes the hibernation file or partition
- /INFO displays information on the hibernation file or partition
- /REFORMAT PARTITION reformats the existing hibernation file or partition



Caution: The Hibernation file is a hidden file named **SAVE2DSK.BIN**; **DO NOT** delete or alter this file in any way except by using the **PHDISK** utility. Improper deletion or alteration of this file could cause you to lose all access to your computer.

Notebook Manager

Notebook Manager

The computer has a built-in system setup program called Notebook Manager. The Windows-based Notebook Manager allows you to set passwords, the startup sequence of the drives and power management settings. It also shows current hardware configurations.



Note: Certain hot key functions are disabled when you access the notebook manager, because these functions are also found in the notebook manager.

To start the Notebook Manager, press **Fn-F2** or follow these steps:

1. Click on Start, Programs, then Notebook Manager.
2. Select the Notebook Manager application to run the program.



Note: Changes made to most settings in the Notebook Manager take effect the next time the computer restarts. If you make changes in the Power Management and Display Device screen, these changes take effect immediately.

Notebook Manager consists of five sections:

- Information Viewer
- Boot Sequence
- Password
- Power Management
- Display Device

To select a section, click on the tab of the section you want to view.

Notebook Manager

Information Viewer

Information Viewer summarizes and lists information about the specifications and settings of the different components of your computer.

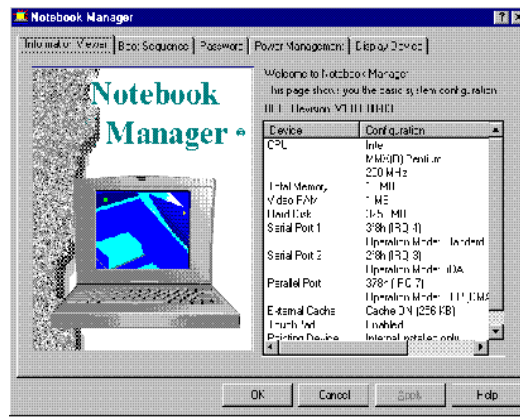

Note: Items in this table may differ slightly from the ones onscreen.

Item	Description
CPU	Brand, type and clock speed of the CPU (Central Processing Unit)
Total Memory	Total amount of main memory (in megabytes)
Video RAM	Total amount of video memory (in megabytes)
Hard Disk	Size of hard disk (in megabytes)
Serial Port 1	Resource settings of serial port 1
Serial Port 2	Resource settings of serial port 2

Notebook Manager

Item	Description
Parallel Port	Resource settings of the parallel port
External Cache	Total amount of external cache memory (in kilobytes)
Touchpad	Setting of the internal pointing device
Pointing Device	Type(s) of the pointing device(s) detected, internal and external

The current version of the computer's BIOS is shown above the Device-Configuration table.

Boot Sequence

Boot Sequence defines the boot sequence to follow when your computer boots up.

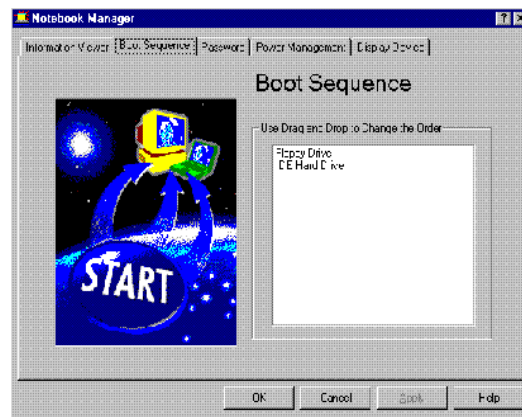

The Boot Sequence screen displays the bootable devices in your computer and the order in which the booting sequence will occur. The devices include the following:

- Floppy Drive

Notebook Manager

IDE Hard Drive

Simply drag and drop the devices to change the booting order. Click on **Apply** to accept the sequence.

Password

Password is used to set, modify or delete the password(s) for your computer.



There are two passwords used in the system:

- Supervisor Password.** The supervisor password prevents unauthorized access to sensitive parameters in the Notebook Manager and BIOS Utility. It also prevents unauthorized access to your computer at system startup and at resume from standby/hibernation mode.
- User Password.** The user password prevents unauthorized access to your computer at system startup and at resume from standby/hibernation mode.

Notebook Manager

Setting the Supervisor Password



Note: Before you can set the User Password, you need to set the Supervisor Password.

To set the Supervisor Password, follow these steps:

1. Click on the Change Supervisor Password button. The following dialog box displays:

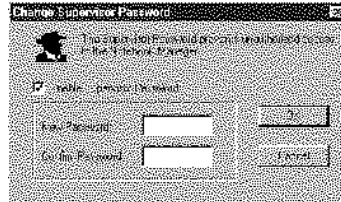

2. Click on the Enable Supervisor Password checkbox.
3. Click in the New Password textbox and type in up to seven alphanumeric characters (A-Z, a-z, 0-9) which you want to be your Supervisor Password.
4. Click in the Confirm Password textbox and retype the password.
5. Click on **OK** to accept it.



Note: To change a password, follow the same steps used to set a password. To remove a password, follow the same steps used to set a password but leave both fields blank.

Notebook Manager

Setting the User Password

To set the User Password, follow these steps:

1. Click on the Change User Password button.

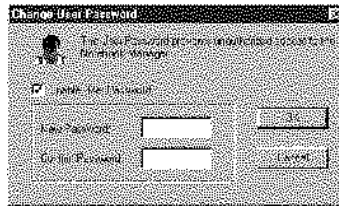

2. Click on the Enable User Password checkbox.
3. Click in the New Password textbox and type in up to seven alphanumeric characters (A-Z, a-z, 0-9) which you want to be your User Password.
4. Click in the Confirm Password textbox and retype the password.
5. Click on **OK** to accept it.



Note: To change a password, follow the same steps used to set a password. To remove a password, follow the same steps used to set a password but leave both fields blank.

You can also set password checks when the computer boots up and/or when the computer resumes from standby/ hibernation mode. Simply click on the desired checkbox(es) and click on **Apply**.

Notebook Manager

Power Management

Power Management is used to set various settings related to power management.

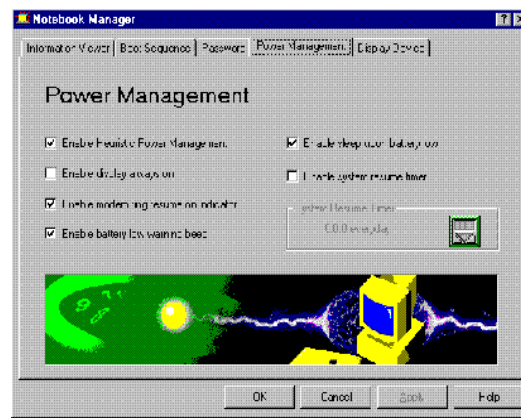

This includes the following power-saving-related features:

- Enable Heuristic Power Management.** Select to enable heuristic power management. See “Power Management” on page 39 for more information on heuristic power management.
- Enable display always on.** Select to leave your display always turned on, useful when you need to make presentations on your computer.
- Enable modem ring resume on indicator.** Select to allow the computer to wake-up from standby mode when an incoming modem ring is detected.
- Enable battery low warning beep.** Select to allow the computer to give off warning beeps when the computer runs low on battery.
- Enable sleep upon battery low.** Select to allow the computer to enter standby or hibernation mode when the computer runs low on battery.

Notebook Manager

- Enable system resume timer. Select to allow the computer to wake-up from standby mode if the resume timer is set and matched.
- System Resume Timer. When Enable system resume timer is selected, click on the button to set the System Resume Timer.

Display Device

Display Device is used to control various settings related to display device(s), such as the display brightness/contrast levels.

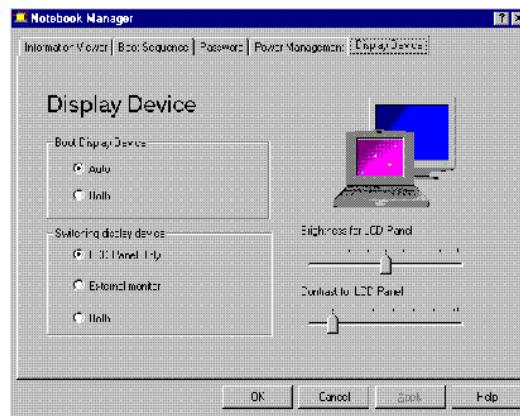

The items in this screen include:

- Boot Display Device. Sets the default display device on boot-up.
- Switching Display Device. Sets the current display device.



Note: Make sure an external monitor is connected before External monitor is selected.

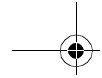

Notebook Manager

- Brightness for LCD Panel/Contrast for LCD Panel. Click and drag to set the LCD screen brightness and contrast levels.



Note: TFT active-matrix LCDs have fixed and optimized contrast levels.

Click on the radio button of the desired item, then click on **Apply** to accept. To modify the brightness and/or contrast levels, click and hold the slider control and move to the right to increase, move to the left to decrease the setting. You can also click on the item, and use the cursor keys to set the desired level.

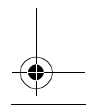
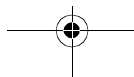
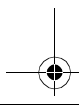
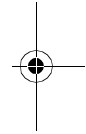
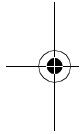

Setup Utility

Setup Utility

The Setup Utility is a hardware configuration program built into your computer's BIOS (Basic Input/Output System).

Your computer is already properly configured and optimized, and you do not need to run this utility. However, if you encounter configuration problems, you may need to run Setup. Please also refer to Chapter 6, Troubleshooting when a problem arises.

To activate the Setup Utility, press **F2** during POST (while the Travelmate logo is being displayed).

Navigating the Setup Utility

There are five menu options: Main, Advanced, Security, Power Saving and Exit. To navigate the Setup Utility:

- Press the cursor right/left keys →← to move between the main menu items.
- Press **Esc** while you are in any of the menu options to display the Exit menu.
- Press the cursor up/down keys ↑↓ to move between parameters.
- Press the plus/minus keys +- to change the value of a parameter.



Note: You can change the value of a parameter if it is enclosed in square brackets.

- Press the **Enter** key to access a submenu. A > symbol in front of a parameter denotes an item with a submenu.



Note: Parameter explanations are displayed in the Item-Specific Help section of the Setup Utility (right panel). Navigation keys are shown on the bottom of the screen.

Setup Utility

Main

The Main screen contains parameters involving basic computer settings and hardware information.

Main	Advanced	Security	Power Saving	Exit	Item Specific Help
System Time:		[07:23:00]			
System Date:		[04/07/1998]			
Floppy Disk A:		[1.44 MB 3½"]			
▶ Hard Disk 0		(C: 2168 MB)			
▶ Boot Device Priority					
System Memory:		16 MB			
Video Memory:		1 MB			
CPU Type:		Pentium MMX			
CPU Speed:		200 Mhz			
VGA BIOS Version:		V1.14.004 R01K			
BIOS Version:		V1.0 R01-31			
F1 Help	↑↓ Select Item	-/+ Change Values	F9 Setup Defaults		
Esc Exit	←→ Select Menu	Enter Select ▶ Sub-Menu	F10 Save and Exit		

The following table describes the parameters in this screen. Settings in boldface are the default and suggested parameter settings.

Parameter	Description
System Time	Sets the system time. Format: HH:MM:SS (hour:minute:second)
System Date	Sets the system date. Format: DD/MM/YYYY (day/month/year)
Floppy Disk A	Selects the floppy disk drive type. Options: 1.44 MB , 3½" or Disabled.
Hard Disk 0	Shows the hard disk size. Press Enter to access the Hard Disk 0 submenu.
Boot Device Priority	Press Enter to access the Boot Device Priority submenu.

Setup Utility

Parameter	Description
System Memory	Shows the size of main memory.
Video Memory	Shows the size of video memory.
CPU Type	Shows the type of the CPU.
CPU Speed	Shows the speed of the CPU.
VGA BIOS Version	Shows the version number of the VGA BIOS. Format: Vx Rx (version and release numbers)
BIOS Version	Shows the version number of the BIOS. Format: Vx Rx (version and release numbers)



Note: *The BIOS versions are important information about your computer. If you experience computer problems and need to contact technical support, this data helps our service personnel know more about your computer.*

Setup Utility

Hard Disk 0 Submenu

The hard disk 0 submenu allows you to set parameters related to your hard disk. Press **Enter** to access this submenu.

Main		Item Specific Help
Hard Disk 0 (C: 2168 MB)		
Type:	[Auto]	
Cylinder:	[4200]	
Heads:	[16]	
Sectors:	[63]	
Maximum Capacity:	2168 MB	
Multi-Sector Transfer:	[16 Sectors]	
LBA Mode Control:	[Enabled]	
32 Bit I/O:	[Disabled]	
Transfer Mode:	[Fast PIO 4]	
Ultra DMA Mode:	[Mode 2]	

The following table describes the parameters in this screen. Settings in boldface are the default and suggested parameter settings.

Parameter	Description
Type	Sets the hard disk type. Options: Auto , User or None
Cylinders	Shows the number of cylinders of the hard disk.
Heads	Shows the number of heads of the hard disk.
Sectors	Shows the number of sectors per track of the hard disk.
Maximum Capacity	Shows the maximum capacity of the hard disk.

Setup Utility



Note: The values for Cylinder, Heads, Sectors/Track and Maximum Capacity are automatically set when the hard disk type is set to Auto. We suggest you set the hard disk type to [Auto] for hassle-free and correct hard disk detection. The computer's BIOS automatically sets the parameters in this screen to their optimal values.

Boot Device Priority Submenu

The Boot Device Priority submenu allows you to set the boot sequence of the bootable devices in your computer. Press **Enter** to access this submenu.

Main	
Boot Device Priority:	Item Specific Help
1. [Diskette Drive A]	
2. [Hard Drive 0]	

The computer boots-up using the sequence specified in this submenu. To set the boot device priority, use the plus/minus +/- keys.

Setup Utility

Advanced

The Advanced screen contains parameters that are related to computer hardware.



Caution: The parameters in this screen are for advanced users only. You do not need to change the values in this screen because these values are already optimized.

Main	Advanced	Security	Power Saving	Exit	Item Specific Help
Warning! Setting items on this menu to incorrect values may cause your system to malfunction.					
Serial Port:	[Enabled]				
Base I/O Address	[3F8]				
Interrupt	[IRQ 4]				
Parallel Port:	[Enabled]				
Operation Mode	[ECP]				
Base I/O Address	[3F8]				
Interrupt	[IRQ 7]				
ECP DMA	[DMA 3]				
Speaker:	[Enabled]				
Boot Display Device:	[Auto]				

The following table describes the parameters in this screen. Settings in boldface are the default and suggested parameter settings.

Parameter	Description
Serial Port	Enables or disabled the serial port. Options: Enabled or Disabled
Base I/O Address	Sets the I/O address of the serial port. Options: 3F8 , 2F8, 3E8 or 2E8
Interrupt	Sets the interrupt request of the serial port. Options: IRQ3, IRQ4 , IRQ10 or IRQ11

Setup Utility

Parameter	Description
Parallel Port	Enables or disables the parallel port. Options: Enabled or Disabled
Operation mode	Sets the operation mode of the parallel port. Options: Output only, Bi-directional, or ECP
Base I/O Address	Sets the I/O address of the parallel port. Options: 378 , 278, or 3BC
Interrupt	Sets the interrupt request of the parallel port. Options: IRQ 7 or IRQ 5
ECP DMA	Assigns DMA channel 1 or DMA channel 3 for ECP parallel port function. This item becomes active only if you select Extended Capabilities Port (ECP) as the operation mode. Options: DMA 1 or DMA 3
Speaker	Enables or disables the internal speakers. You can override this by toggling Fn-F6 during computer operation. Options: Enabled or Disabled
Boot Display Device	Sets the display on boot-up. When set to Auto, the computer automatically determines the display device. If an external display device (e.g., monitor) is connected, it becomes the boot display; otherwise, the computer LCD is the boot display. When set to Both, the computer outputs to both the computer LCD and an external display device if one is connected. Options: Auto or Both

Setup Utility

Security

The Security screen contains parameters that help safeguard and protect your computer from unauthorized use.

Main	Advanced	Security	Power Saving	Exit	Item Specific Help
		Supervisor Password is	[Disabled]		
		User Password is	[Disabled]		
		Set Supervisor Password	[Enter]		
		Set User Password	[Enter]		
		Password on boot:	[Enabled]		
		Password check during Resume:	[Disabled]		

The following table describes the parameters in this screen. Settings in boldface are the default and suggested parameter settings.

Parameter	Description
Supervisor Password is	When set, this password protects the computer and this Setup Utility from unauthorized entry. It also protects certain parameters in the Setup Utility. When Password on boot and/or Password check during Resume is enabled, you need to enter this password to continue operation. Options: Disabled or Enabled

Setup Utility

Parameter	Description
User Password is	<p>When set, this password protects the computer and this Setup Utility from unauthorized entry.</p> <p>When Password on boot and/or Password check during Resume is enabled, you need to enter this password to continue operation.</p> <p>Before setting the user password, you need to set the Supervisor Password.</p> <p>Options: Disabled or Enabled</p>
Set Supervisor Password	<p>Press Enter to set the supervisor password. See "Setting a Password" on page 89 for how to set a password.</p>
Set User Password	<p>Press Enter to set the user password. See "Setting a Password" on page 89 for how to set a password.</p>
Password on boot	<p>When enabled, the computer prompts you for a password when the computer boots up.</p> <p>Options: Enabled or Disabled</p>
Password check during Resume	<p>When enabled, the computer prompts you for a password when the computer resumes from standby or hibernation mode.</p> <p>Options: Disabled or Enabled</p>



Note: To set the User Password or the Password on boot and Password check during Resume parameters, you need to set the Supervisor Password first.

Setting a Password

Follow these steps:

1. Use the ↑ and ↓ keys to highlight a Set Password parameter (Supervisor or User) and press the **Enter** key.

Setup Utility

The password box appears:

Set Password	
Enter new password:	(□□□□□□□)
Re-enter new password:	()

2. Type a password. The password may consist of up to seven characters (A-Z, a-z, 0-9).



Important: Be very careful when typing your password because the characters do not appear on the screen.

3. Press **Enter**. Retype the password to verify your first entry and press **Enter**.

After setting the password, the computer automatically sets the chosen password parameter to Enabled.

4. Press **Esc** to go to the Exit menu.
5. Press **Save Change & Exit** to save the password and exit the Setup Utility.

To change a password, follow the same steps used to set a password.

Removing a Password

Should you want to remove a password, do the following:

1. Use the ↑ and ↓ keys to highlight a Set Password parameter (Supervisor or User) and press the **Enter** key. The password box appears:

Set Password	
Enter Current Password:	()
Enter new password:	()
Re-enter new password:	()

2. Enter your current password in the first parameter and then press **Enter**.
3. Press **Enter** twice without entering anything in the next two password box to remove the existing password.
4. Press **Esc** to go to the Exit menu.

Setup Utility

5. Press **Save Change & Exit** to save the password and exit the Setup Utility.

Power Saving

The Power Saving screen contains parameters that are related to power-saving and power management.

Main	Advanced	Security	Power Saving	Exit
			Heuristic Power Management:	[Enabled]
			Display Always On	[Disabled]
			Battery Low Suspend:	[Enabled]
			Resume on Modem Ring:	[On]
			Resume on Time:	[Off]
			Resume Time:	[00:00:00]
			Resume Date:	[00/00/0000]
			Battery Low Warning Beep:	[Enabled]
				Item Specific Help

The following table describes the parameters in this screen. Settings in boldface are the default and suggested parameter settings.

Parameter	Description
Heuristic Power Management	Enables or disables power management based on timeout settings in this screen. See "Power Management" on page 39 for more information on power management modes. Options: Enabled or Disabled

Setup Utility

Parameter	Description
Display Always On	<p>When enabled the computer does not enter display standby mode.</p> <p>Always enable this parameter when playing VCDs (Video Compact Disc). If not, the system will enter standby mode after 30 minutes and the screen will go blank.</p> <p>Options: Enabled or Disabled</p>
Battery Low Suspend	<p>Enables or disables the suspend function during a battery-low condition. When the computer is running very low on battery power, the computer will enter suspend mode if PhDISK is installed and the suspend file is valid. See "PhDISK" on page 71.</p> <p>Options: Enabled or Disabled</p>
Resume on Modem Ring	<p>When on, and an incoming modem ring is detected, the computer wakes up from suspend mode.</p> <p>Options: On or Off</p>
Resume on Time	<p>When on and the system resume date and time are valid, the computer resumes (wakes up) at the set time and date.</p> <p>Options: On or Off</p>
Resume Time	<p>Sets the time the computer resumes from if Resume on Time is on.</p> <p>Format: HH:MM:SS (hour:minutes:seconds)</p>
Resume Date	<p>Sets the date the computer resumes from if Resume on Time is on.</p> <p>Format: DD/MM/YYYY (day/month/year)</p>
Battery Low Warning Beep	<p>Enables or disables warning beeps during a battery-low condition.</p> <p>Options: Enabled or Disabled</p>

Setup Utility

Exit

When you select the Exit menu or press **Esc** from any screen, the Exit options screen displays.

Main	Advanced	Security	Power Saving	Exit	Item Specific Help
Exit Saving changes Exit Discarding Changes Load Setup Defaults Load Previous Values Save Changes					

The following table describes the parameters in this screen.

Parameter	Description
Exit Saving Changes	Saves any changes made, exits the Setup utility and reboots.
Exit Discarding Changes	Discards any changes made, exits the Setup utility and reboots.
Load Setup Defaults	Resets all parameters to their factory-default values.
Load Previous Values	Disregards any changes made in the current session and reloads their previous values.
Save Changes	Saves any changes made.

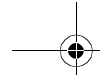

Setup Utility



Note: If you make any parameter changes, select *Exit Saving Changes* or *Save Changes* to store your changes.

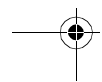
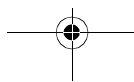
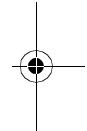
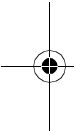

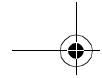

6

Troubleshooting

This chapter instructs you on how to deal with common system problems. Read it before calling a technician if a problem occurs. Solutions to more serious problems require opening up the computer. Do not attempt to open the computer by yourself. Contact your dealer or an authorized service center for assistance.

Contents

Frequently-Asked Questions	96
Error Messages	100

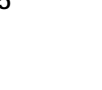
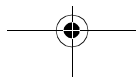
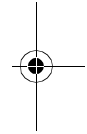
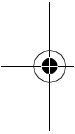

Frequently-Asked Questions

Frequently-Asked Questions

This is a list of possible situations that may arise during the use of your computer, and gives easy answers and solutions to these questions.

I pressed the power switch and opened the display, but the computer does not start or boot-up.

Look at the Power indicator:

- If it is not lit, no power is being applied to the computer. Check the following:
 - If you are running on battery power, it may be low and unable to power the computer. Connect the AC adapter to recharge the battery pack.
 - Make sure the AC adapter is plugged in properly to the computer and to the power outlet.
- If it is lit, check the following:
 - If the Standby indicator is lit, the computer is in standby mode. Press any key, the power button or tap on the touchpad to resume.
 - Is a non-bootable (non-system) diskette in the floppy drive? Remove or replace it with a system diskette and press Ctrl-Alt-Del to restart the system.

The operating system files may be damaged or missing. Insert the startup disk you created during Windows 95 or Windows 98 setup into the floppy drive and press Ctrl-Alt-Del to restart the system. This will diagnose your system and make necessary fixes.

Nothing appears on the screen.

The computer's power management system automatically blanks the screen to save power. Press any key to turn the display back on.

Frequently-Asked Questions

If pressing a key does not turn the display back on, two things might be the cause:

- The contrast and/or brightness level might be too low. Press Fn-F12(up) and Fn-F11(down) to adjust the contrast level (only for models with STN LCDs). Press Fn-F9(down) and Fn-F10(up) to adjust the brightness level.
- The display device might be set to an external monitor. Press the display toggle hot key Fn-F5 to toggle the display back to the computer.

Image is not full-screen.

Make sure the resolution is set to 800x600. Right-click on your Windows 95 or Windows 98 desktop and select Properties to bring up the Display Properties dialog box. Then click on the Settings tab to make sure the resolution is set to 800x600. 640x480 resolution is not full-screen on the computer or on an external monitor.

No audio from the computer.

- The volume may be muted. In Windows 95 or Windows 98, look at the volume control icon on the taskbar. If it is crossed-out, click on the icon and de-select the Mute option.
- The speakers may be turned off. Press Fn-F6 to turn the speakers on (this hot key also turns the speakers off).
- The volume level may be too low. In Windows 95 or Windows 98, look at the volume control icon on the taskbar. Click on the icon and adjust the level. You can also press Fn-F7(down) and Fn-F8(up) to adjust the volume.

If headphones, earphones or external speakers are connected to the line-out port on the computer's right panel, the internal speaker automatically turns off.

Frequently-Asked Questions

The keyboard does not respond.

Try attaching an external keyboard to the PS/2 connector on the computer's rear. If it works, contact your dealer or an authorized service center as the internal keyboard cable may be loose.

The serial mouse does not work.

- Make sure that the serial cable is plugged securely into the serial port.
- During POST, press F2 to access the Setup Utility. Go to the Advanced screen and verify that the serial port is enabled and has no conflicts with other serial devices (IrDA). See "Advanced" on page 86 for details.

The printer does not work.

- Make sure that the printer is connected to a power outlet and it is turned on.
- Make sure the printer cable is connected securely to the computer's parallel port and the corresponding port on the printer.
- During POST, press F2 to access the Setup Utility. Go to the Advanced screen and verify that the parallel port is enabled. See "Advanced" on page 86 for details.

I prefer using an external keyboard and mouse, but both have PS/2 connectors and there is only one PS/2 port on the computer.

To connect two PS/2-type devices to the computer, you need to use a PS/2 Y-bridge connector. See "PS/2 Y-Bridge Cable" on page 56 for details.

I want to set-up my location to use the internal modem.

To properly use your communications software (e.g., HyperTerminal), you need to set-up your location:

Frequently-Asked Questions

1. Open the Windows 95 or Windows 98 Control Panel and double-click on the Modems icon.
2. Click on Dialing Properties and begin setting up your location.

I prefer to use an external floppy drive and a printer simultaneously.

To connect an external floppy drive and a printer at the same time, you need to use a parallel cable. See "Parallel Cable" on page 57 for details.

The infrared port does not work.

Check the following:

- Make sure that the infrared ports of the two devices are facing each other (+/- 15 degrees) a maximum of 1 meter apart.
- Make sure there is a clear path between the two infrared ports. Nothing should be blocking the ports.
- Make sure you have the appropriate software running on both devices (for file transfers) or you have the appropriate drivers (for printing to an infrared printer).
- During POST, press F2 to access the Setup Utility. Go to the Advanced screen and verify that the infrared port is enabled.
- Make sure both devices are IrDA-compliant.
- For Windows 98 users: Windows 98 have a built-in FIR driver that conflicts with IntelLync 97 when use simultaneously. To use the IntelLync 97 driver, you must first disable the Windows 98 built-in driver. To disable the Windows 98 built-in driver, click **Control Panel -> Infrared -> Options** and then uncheck the **Enable Infrared Communications** parameter.

Error Messages

Error Messages

If you receive an error message, note the message and take the corrective action. The following table lists the error messages in alphabetical order together with the recommended course of action.

Error Messages	Corrective Action
CMOS Battery Bad	Contact your dealer or an authorized service center.
CMOS Checksum Error	Contact your dealer or an authorized service center.
Disk Boot Failure	Insert a system disk in drive A, then press Enter.
Diskette Drive Controller Error or No Controller Present	Contact your dealer or an authorized service center.
Diskette Drive Error	Contact your dealer or an authorized service center.
Diskette Drive Type Mismatch	Press F2 (during POST) to reconfigure the computer.
Equipment Configuration Error	Press F2 (during POST) to reconfigure the computer.
Hard Disk 0 Error	Contact your dealer or an authorized service center.
Hard Disk 0 Extended Type Error	Contact your dealer or an authorized service center.
I/O Parity Error	Contact your dealer or an authorized service center.
Insert system diskette and press <Enter> key to reboot	Insert a system disk in drive A, then press Enter.

Error Messages

Error Messages	Corrective Action
Keyboard Error or No Keyboard Connected	Contact your dealer or an authorized service center.
Keyboard Interface Error	Contact your dealer or an authorized service center.
Memory Size Mismatch	Enter and then exit the System Configuration Setup in the Setup utility (pressing F2 during POST).
Missing operating system	Correct the HDD type and reboot. See the specification label attached to hard disk drive. We suggest you set the HDD type to [Auto] for hard disk drive auto-detection.
Non-system disk or disk error. Replace and strike any key when ready	Insert a system disk in drive A, then press Enter.
Pointing Device Error	Contact your dealer or an authorized service center.
Pointing Device Interface Error	Contact your dealer or an authorized service center.
Protected Mode Test Fail	Contact your dealer or an authorized service center.
RAM BIOS Bad	Contact your dealer or an authorized service center.
RAM Parity Error	Contact your dealer or an authorized service center.
Real-Time Clock Error	Press F2 (during POST) to reconfigure the computer.

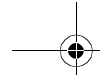

Error Messages

Error Messages	Corrective Action
Video RAM BIOS Bad	Contact your dealer or an authorized service center.

If you still encounter problems after going through the corrective measures, please contact your dealer or an authorized service center for assistance. Some problems may be solved using the BIOS Setup Utility. See "Setup Utility" on page 81.

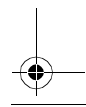
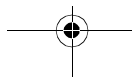
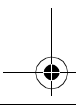
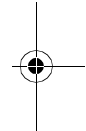
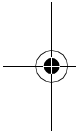

A

Specifications

This appendix lists the general specifications of your computer.

Microprocessor

Intel Mobile Module (IMM) with:

- Intel Pentium® processor with MMX™ technology
- Integrated 256KB Level 2 cache memory

Memory

- 16MB main memory expandable to 80 MB
- One 144-pin soDIMM socket (SDRAM memory type)
- 64-bit dual memory banks
- 256KB Flash ROM BIOS

Data Storage

- One 2.5-inch, 9.5mm hard disk

Display and Video

- 8.0-inch Supertwist Nematic (STN) LCD, or 8.4-inch high color Thin Film Transistor (TFT) LCD
- 640x480 VGA resolution (8.0-inch STN) or 800x600 SVGA resolution (8.4-inch TFT)
- Integrated 128-bit graphics accelerator (PCI) and 1.1MB EDO video memory
- Simultaneous LCD and CRT display

Audio

- 16-bit stereo audio (PnP ISA)
- 3-dimensional sound
- One speaker

Specifications

- Sound Blaster Pro- and Windows Sound System-compatible
- Separate audio ports for line-out and microphone-in devices

Keyboard and Pointing Device

- 83-/85-key Windows keyboard
- Ergonomically-centered touchpad pointing device

I/O Ports

- Two type II/I or one type III CardBus socket(s)
- One RJ-11 phone jack
- One DC-in jack (AC adapter)
- One FIR wireless communications port (IrDA-compliant)
- One RS-232 serial port (UART16550-compatible)
- One parallel port (ECP-compliant) or external FDD port
- One external monitor port (DDC 2.0-compliant)
- One keyboard/mouse port (PS/2-compatible)
- One speaker-out jack
- One microphone-in jack
- One USB port

Weight and Dimensions

- 1.32 kg (2.9 lbs)
- 236 x 175 x 36 mm (9.29 x 6.89 x 1.42 in)

Temperature

- Operating: 10°C ~ 35°C
- Non-operating: -20°C ~ +60°C

Specifications

Humidity (non-condensing)

- Operating: 20% ~ 80% RH
- Non-operating: 20% ~ 80% RH

System

- Windows 95 or higher operating system

Battery Pack

- 16.2-WattHour Lithium-Ion battery pack
- Smart battery management technology
- 2~3-hour rapid charge for Li-Ion.

AC Adapter

- 36-Watt
- Auto sensing 100~240Vac, 50~60Hz

Options

- 16-/32-/64-MB SDRAM memory upgrade module
- Higher-capacity hard disk drive
- PS/2 Y-cable for external mouse and keyboard
- Parallel cable for external floppy drive and printer
- Additional AC adapter and battery pack
- External PCMCIA CD-ROM drive (optional)

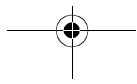
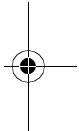
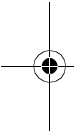

Index

A

- AC adapter
 - caring for xviii
 - connecting xv
- Advanced Power Management
 - 43
- APM. See Advanced Power Management
- audio
 - connecting externally 52

B

- battery
 - installing xiv
- battery pack
 - battery-low warning 32
 - caring for xix
 - characteristics 32
 - charging modes 34
 - checking charge level 35
 - installing 33
 - low conditions 38
 - optimizing 36
 - removing 33
 - using the first time 32
- boot order
 - setting in Notebook Manager 74
 - setting in Setup Utility 85
- brightness
 - setting in Notebook Manager 80

C

- caps lock
 - on indicator 6
- care
 - AC adapter

AC adapter

- caring for xviii
 - battery pack xix
 - computer xviii
- cleaning
 - computer xix
- computer
 - bringing to meetings 63
 - caring for xviii
 - cleaning xix
 - connecting xiv
 - disconnecting 62
 - features 2
 - information 73
 - microphone 6
 - moving around 63
 - on indicator 6
 - power management 39
 - security 28
 - setting up a home office 65
 - taking home 64
 - traveling internationally 67
 - traveling on local trips 66
 - troubleshooting 95
 - turning on xv
- connections
 - AC adapter xv
 - audio 52
 - computer xiv
 - file transfer cable 58
 - floppy drive, external 18
 - keyboard, external 47
 - keypad, external 48
 - mouse, PS/2 49
 - mouse, serial 50
 - printer 51
 - PS/2 y-bridge cable 56
 - USB 55

Index

contrast
 setting in Notebook
 Manager 80

D

date
 setting in Setup Utility 82

display
 auto-dim feature 39
 hot keys 12
 opening and closing 4
 performance 4
 power management 4, 39
 setting boot device in
 Notebook Manager 79
 setting in Notebook
 Manager 79
 simultaneous 4
 switching device in
 Notebook Manager 79
 troubleshooting 96, 97

E

error messages 100
External 49

F

FAQ. See frequently-asked
 questions
file transfer cable
 connecting 58
FIR. See infrared
floppy drive 17
frequently-asked questions 96

H

hard disk

upgrade 60

help

Internet home page xvi
online help xvi
support information xvii

Heuristic Power

Management 91

Hibernation mode 41

 conditions 42

 entering 42

 hot key 11

 resuming from 42

 utility 71

hot keys 11

HPM. See Heuristic Power
Management

I

indicator lights 6

infrared 19

ITW. See warranty

K

keyboard 8

 embedded numeric keypad
 9

 hotkeys 11

 lock keys 8

 troubleshooting 98

 Windows keys 10

keypad

 connecting externally 48

L

LEDs 6

Index

M

media activity
 on indicator 6
 memory
 configurations 59
 upgrading 59
 messages
 error 100
 modem 23
 monitor
 connecting 46
 mouse
 connecting externally 49
 troubleshooting 98

N

Notebook Manager 72-80
 Boot Sequence 74
 Display Device 79
 Information Viewer 73
 Password 75
 Power Management 78
 starting 72
 num lock 13
 on indicator 6
 numeric keypad
 embedded 9

O

options
 cables 56
 hard disk upgrade 60
 memory upgrade 59
 PC Cards 53
 spare AC adapter 56
 spare battery pack 56

P

palm rest 14
 password 28
 changing in Setup Utility
 90
 checking during boot 89
 checking during resume 89
 removing in Setup Utility
 90
 setting in Notebook
 Manager 76-77
 setting in Setup Utility 89
 PC Card 23
 ejecting 24
 inserting 24
 peripherals
 power management 39
 PhDISK 71
 ports 19
 rear 19
 right 22
 power
 managing in Notebook
 Manager 78
 managing in Setup Utility
 91
 turning on xv
 power management
 advanced 43
 peripheral standby modes
 40
 power management modes
 display standby mode 39
 hard disk standby 40
 hibernation mode 41
 standby modes 40
 printer
 connecting 51
 troubleshooting 98

Index

- problems 95
 - display 96
 - keyboard 98
 - serial mouse 98
 - startup 96
- PS/2 mouse
 - connecting 49
- PS/2 y-bridge cable
 - connecting 56
- Q**
- questions
 - multiple PS/2 devices 98
 - setting location for modem use 98
- S**
- safety
 - FCC notice vi
 - general instructions viii, xiii
 - lithium battery xi, xix
- security
 - keylocks 28
 - passwords 28
- serial mouse
 - connecting 50
- serial port
 - setting in Setup Utility 86
- service when to call xvii, xix
- Setup Utility 81-94
 - Advanced menu 86
 - Boot Device Priority submenu 85
 - entering 81
 - Exit menu 93
 - Hard Disk 0 submenu 84
 - Main menu 82
 - navigating 81
 - Power Saving menu 91
 - Security menu 88
- software
 - bundled 70
- speakers
 - hot keys 12
- T**
- time
 - setting in Setup Utility 82
- U**
- utility
 - BIOS Setup 81-94
 - Notebook Manager 72-80
 - PhDISK 71
- W**
- warranty
 - International Traveler's Warranty