

# PCG-FX220/FX220K/FX240/FX240K/ PCG-FX250/FX250K/FX270/FX270K

## SERVICE MANUAL

*US Model*  
*Canadian Model*

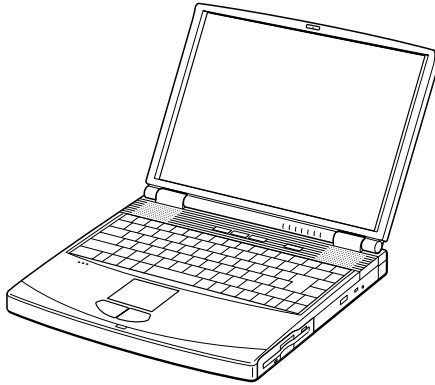

Illust : PCG-FX270K



Confidential

**NOTEBOOK COMPUTER**

**SONY®**

**Information in this document is subject to change without notice.**

Sony and VAIO are trademarks of Sony. Intel logo and Intel Inside logo are registered trademarks of Intel Corporation. Pentium MMX is a trademark of Intel Corporation. Microsoft, MS-DOS, Windows, the Windows 95 and Windows 98 logo are trademarks of Microsoft Corporation.

All other trademarks are trademarks or registered trademarks of their respective owners. Other trademarks and trade names may be used in this document to refer to the entities claiming the marks and names or their products. Sony Corporation disclaims any proprietary interest in trademarks and trade names other than its own.

Caution Markings for Lithium/Ion Battery - The following or similar texts shall be provided on battery pack of equipment or in both the operating and the service instructions.

**CAUTION:** Danger of explosion if battery is incorrectly replaced. Replace only with the same or equivalent type recommended by the manufacturer. Discard used batteries according to the manufacturer's instructions.

**CAUTION:** The battery pack used in this device may present a fire or chemical burn hazard if mistreated. Do not disassemble, heat above 100°C (212°F) or incinerate.

Dispose of used battery promptly.  
Keep away from children.

**CAUTION:** Changing the back up battery.

- Overcharging, short circuiting, reverse charging, mutilation or incineration of the cells must be avoided to prevent one or more of the following occurrences; release of toxic materials, release of hydrogen and/or oxygen gas, rise in surface temperature.
- If a cell has leaked or vented, it should be replaced immediately while avoiding to touch it without any protection.

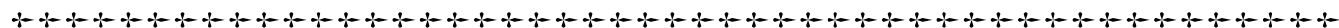

## Service and Inspection Precautions

### 1. Obey precautionary markings and instructions

Labels and stamps on the cabinet, chassis, and components identify areas requiring special precautions. Be sure to observe these precautions, as well as all precautions listed in the operating manual and other associated documents.

### 2. Use designated parts only

The set's components possess important safety characteristics, such as noncombustibility and the ability to tolerate large voltages. Be sure that replacement parts possess the same safety characteristics as the originals. Also remember that the  $\triangle$  mark, which appears in circuit diagrams and parts lists, denotes components that have particularly important safety functions; be extra sure to use only the designated components.

### 3. Always follow the original design when mounting parts and routing wires

The original layout includes various safety features, such as inclusion of insulating materials (tubes and tape) and the mounting of parts above the printer board. In addition, internal wiring has been routed and clamped so as to keep it away from hot or high-voltage parts. When mounting parts or routing wires, therefore, be sure to duplicate the original layout.

### 4. Inspect after completing service

After servicing, inspect to make sure that all screws, components, and wiring have been returned to their original condition. Also check the area around the repair location to ensure that repair work has caused no damage, and confirm safety.

### 5. When replacing chip components...

Never reuse components. Also remember that the negative side of tantalum capacitors is easily damaged by heat.

### 6. When handling flexible print boards...

- The temperature of the soldering-iron tip should be about 270C.
- Do not apply the tip more than three times to the same pattern.
- Handle patterns with care; never apply force.

Caution: Remember that hard disk drives are easily damaged by vibration. Always handle with care.

### ATTENTION AU COMPOSANT AYANT RAPPORT À LA SÉCURITÉ!

LES COMPOSANTS IDENTIFÉS PAR UNE MARQUE  $\triangle$  SUR LES DIAGRAMMES SCHÉMATIQUES ET LA LISTE DES PIÈCES SONT CRITIQUES POUR LA SÉCURITÉ DE FONCTIONNEMENT. NE REMPLACER CES COMPOSANTS QUE PAR DES PIÈSES SONY DONT LES NUMÉROS SONT DONNÉS DANS CE MANUEL OU DANS LES SUPPLÉMENTS PUBLIÉS PAR SONY.

**Confidential**

## TABLE OF CONTENTS

| <u>Section</u>            | <u>Title</u>  | <u>Page</u>       | <u>Section</u>  | <u>Title</u>   | <u>Page</u>       |
|---------------------------|---|-------------------|---|--|-------------------|
| <b>CHAPTER 1. REMOVAL</b> |   |                   | <b>CHAPTER 2. SELF DIAGNOSTICS</b> ..... 2-1<br>(to 2-1)      |  |                   |
| 1-1.                      | Flowchart .....   | 1-1               | <b>CHAPTER 3. BLOCK DIAGRAM</b> ..... 3-1<br>(to 3-2)         |  |                   |
| 1-2.                      | Main Electrical Parts Location Diagram .....                                    | 1-1               | <b>CHAPTER 4. FRAME HARNESS DIAGRAM</b> ..... 4-1<br>(to 4-2) |  |                   |
| 1-3.                      | Removal .....   | 1-2               | <b>CHAPTER 5. EXPLODED VIEWS AND PARTS LIST</b> ..... 5-1     |  |                   |
| 1.                        | Hood Keyboard Assy, Keyboard Unit .....   | 1-2               | 5-1.  | Main Section .....   | 5-3               |
| 2.                        | DC-Fan, Lithium Battery, Combination Drive,<br>DVD-ROM Drive .....              | 1-2               | 5-2.  | LCD Section<br>(FX270/FX270K Model) – Made by HI – .....                 | 5-7               |
| 3.                        | Combination Drive, DVD-ROM Drive .....  | 1-3               | 5-3.  | LCD Section<br>(FX220/FX220K/FX250/FX250K Model)<br>– Made by HI – ..... | 5-9               |
| 1.                        | FX240/FX240K/FX250/FX250K/<br>FX270/FX270K Model .....                          | 1-3               | 5-4.  | LCD Section<br>(FX240/FX240K Model) – Made by HI – .....                 | 5-11              |
| 2.                        | FX220/FX220K Model .....  | 1-3               | 5-5.  | Connector Section .....  | 5-13<br>(to 5-14) |
| 4.                        | HDD, Door Battery .....   | 1-4               | • Abbreviations<br>UC : US model / Canadian model             |  |                   |
| 5.                        | Palm Rest Assy, Touch Pad, CNX-125 Board,<br>Palm Rest Plate, Bracket Pad ..... | 1-4               |   |  |                   |
| 6.                        | Display Assy, Hinge Cover .....   | 1-5               |   |  |                   |
| 7.                        | PWS-13 Board, Latch Detector .....  | 1-6               |   |  |                   |
| 8.                        | PC Card Connector, Modem Card,<br>MBX-49 Board, I/O Bracket .....               | 1-6               |   |  |                   |
| 9.                        | Speaker Unit, SWX-73 Board .....  | 1-7               |   |  |                   |
| 10.                       | SO-DIMM .....   | 1-7               |   |  |                   |
| 11.                       | Modem Card (Removing from the bottom) .....                                     | 1-8               |   |  |                   |
| 12.                       | LCD Section<br>(FX270/FX270K Model) – Made by HI – .....                        | 1-9               |   |  |                   |
| 1.                        | Bezel Housing Assy, LCD unit (15 inch) .....                                    | 1-9               |   |  |                   |
| 2.                        | Inverter Assy, LCD Harness, FPC,<br>Display Hpusing Assy .....                  | 1-10              |   |  |                   |
| 13.                       | LCD Section<br>(FX220/FX220K/FX250/FX250K Model)<br>– Made by HI – .....        | 1-11              |   |  |                   |
| 1.                        | Bezel Housing Assy, LCD unit (15 inch) .....                                    | 1-11              |   |  |                   |
| 2.                        | Inverter Assy, LCD Harness, FPC,<br>Display Hpusing Assy .....                  | 1-12              |   |  |                   |
| 14.                       | LCD Section<br>(FX240/FX240K Model) – Made by HI – .....                        | 1-13              |   |  |                   |
| 1.                        | Bezel Housing Assy (14 inch) .....  | 1-13              |   |  |                   |
| 2.                        | Bracket LCD Left, Bracket LCD Right,<br>LCD Unit (14 inch) .....                | 1-14              |   |  |                   |
| 3.                        | FPC, Inverter Assy, Display Housing Assy,<br>LCD Harness .....                  | 1-14              |   |  |                   |
| 1-4.                      | Replacing the CPU .....   | 1-15              |   |  |                   |
| 1.                        | Socket type 1,2 .....   | 1-15              |   |  |                   |
| 1.                        | Removing the CPU .....  | 1-15              |   |  |                   |
| 2.                        | Installing the CPU .....  | 1-15              |   |  |                   |
| 2.                        | Socket type 3 .....   | 1-16              |   |  |                   |
| 1.                        | Removing the CPU .....  | 1-16              |   |  |                   |
| 2.                        | Installing the CPU .....  | 1-16              |   |  |                   |
| 1-5.                      | Replacing Various Connector on the MBX-49 Board ...                             | 1-17              |   |  |                   |
| 1.                        | Removing the I/O Bracket .....  | 1-17              |   |  |                   |
| 2.                        | Removing the Various Connectors .....   | 1-17              |   |  |                   |
| 1-6.                      | DIP Switch Setting of the MBX-49 Board .....                                    | 1-18<br>(to 1-18) |   |  |                   |

### 1-1. Flowchart

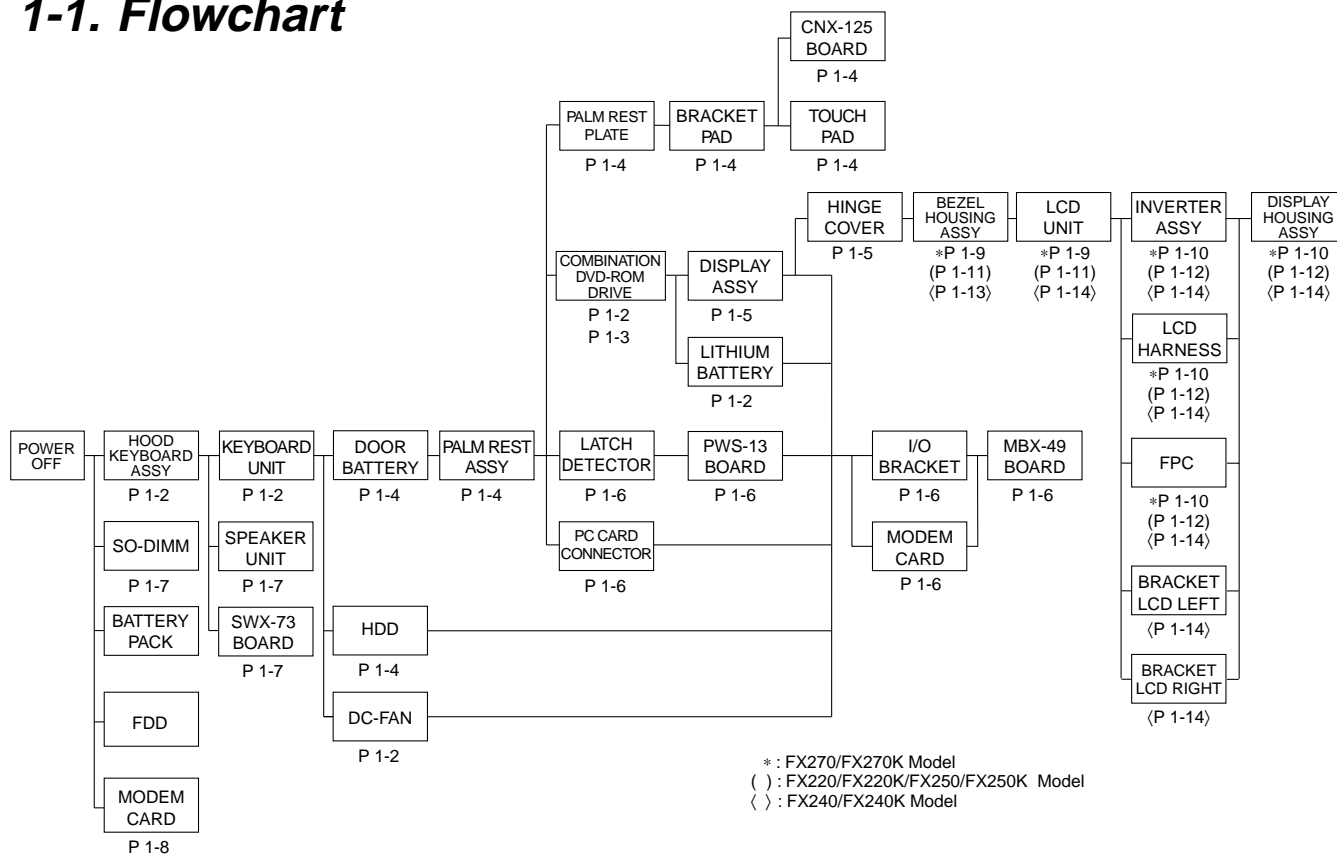

- P XX means pages that appears in this manual.
- Remember that hard disk drives are easily damaged by vibration. Always handle with care.

### 1-2. Main Electrical Parts Location Diagram

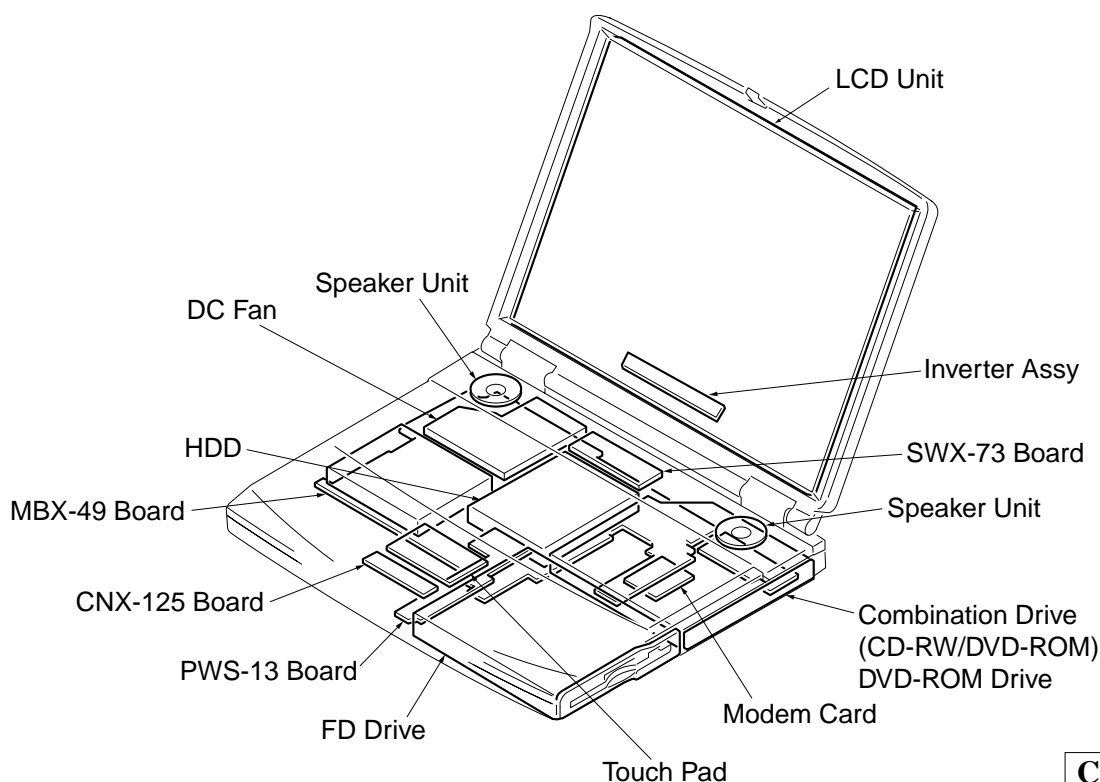

**Confidential**

# 1-3. Removal

## 1. Hood Keyboard Assy, Keyboard Unit

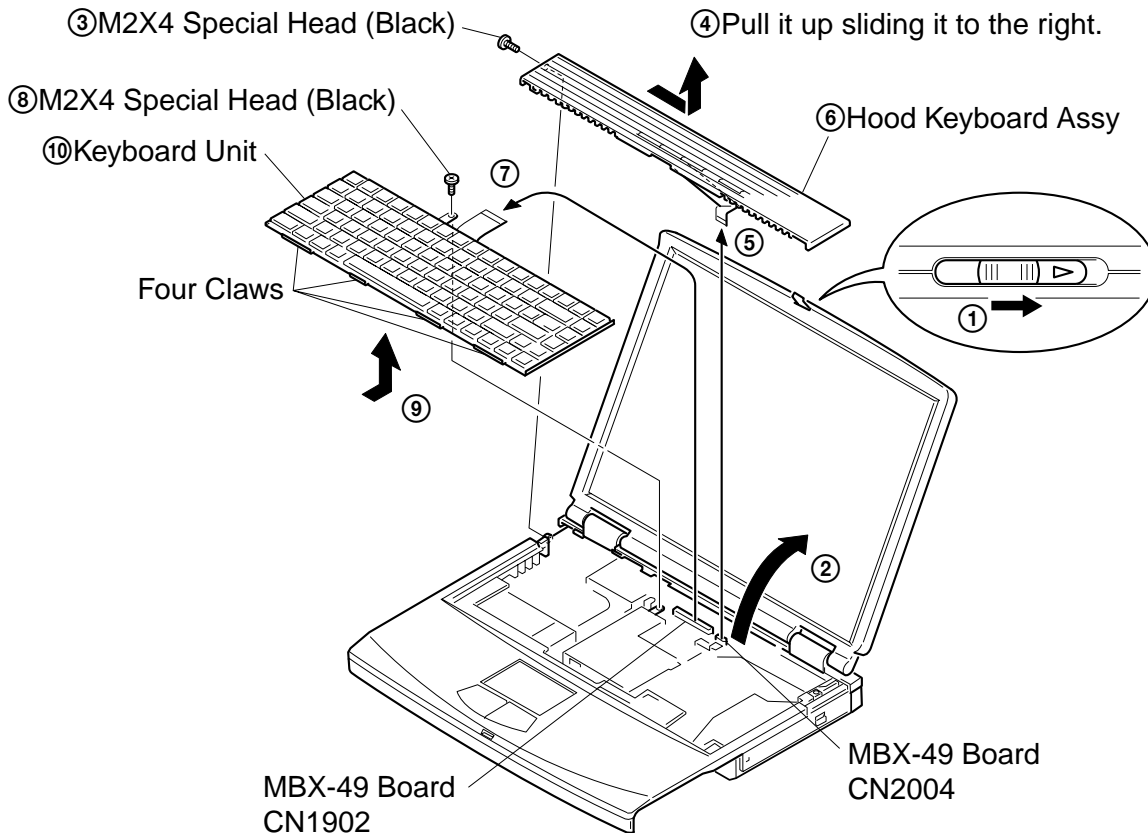

## 2. DC-Fan, Lithium Battery, Combination Drive, DVD-ROM Drive

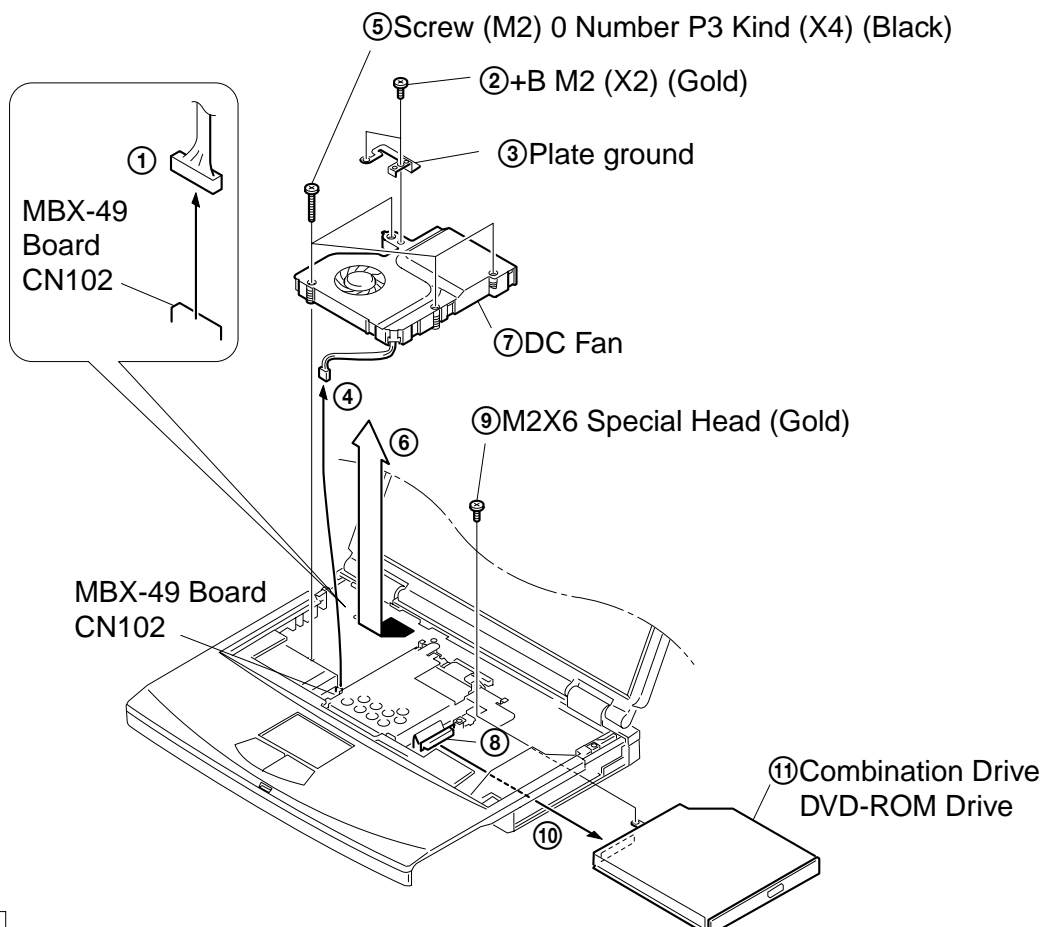

**Confidential**

### 3. Combination Drive, DVD-ROM Drive

#### 1. FX240/FX240K/FX250/FX250K/FX270/FX270K Model

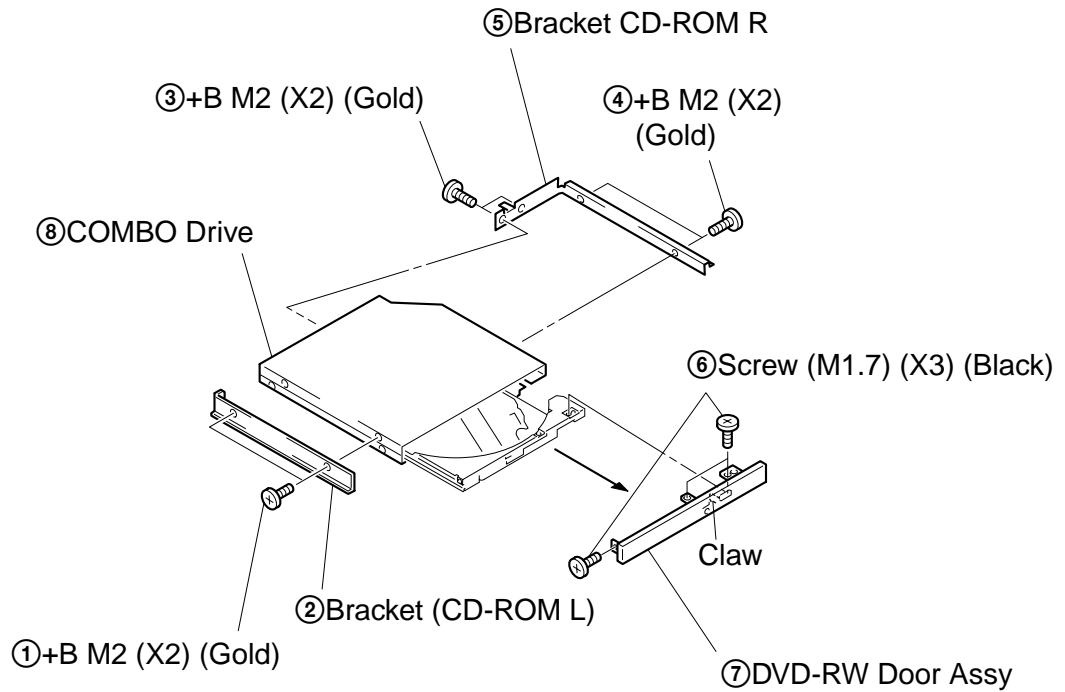

#### 2. FX220/FX220K Model

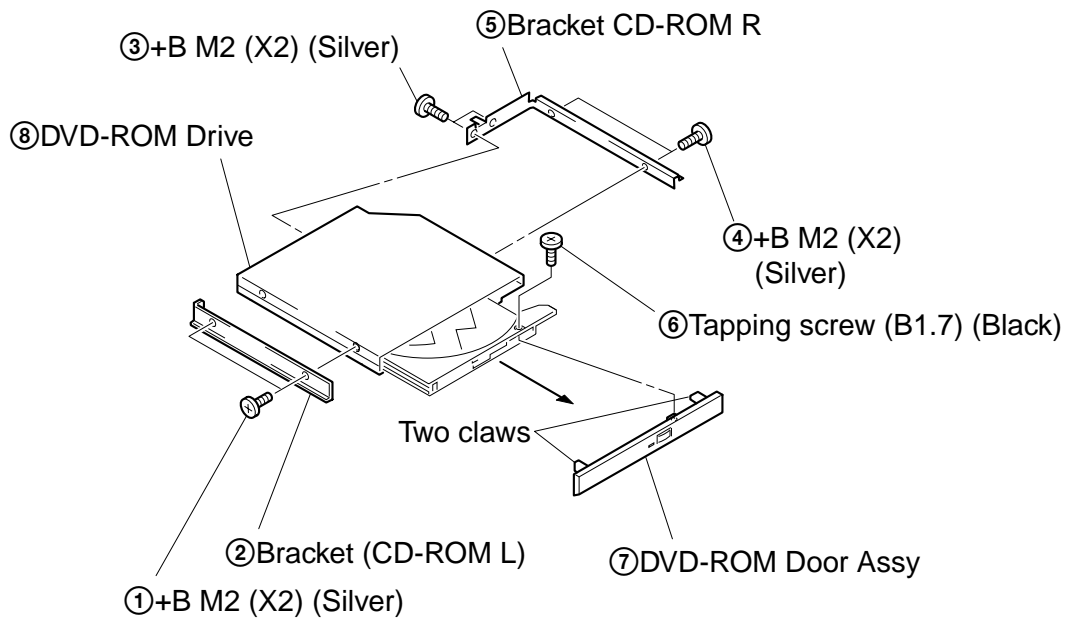

**Confidential**

#### 4. HDD, Door Battery

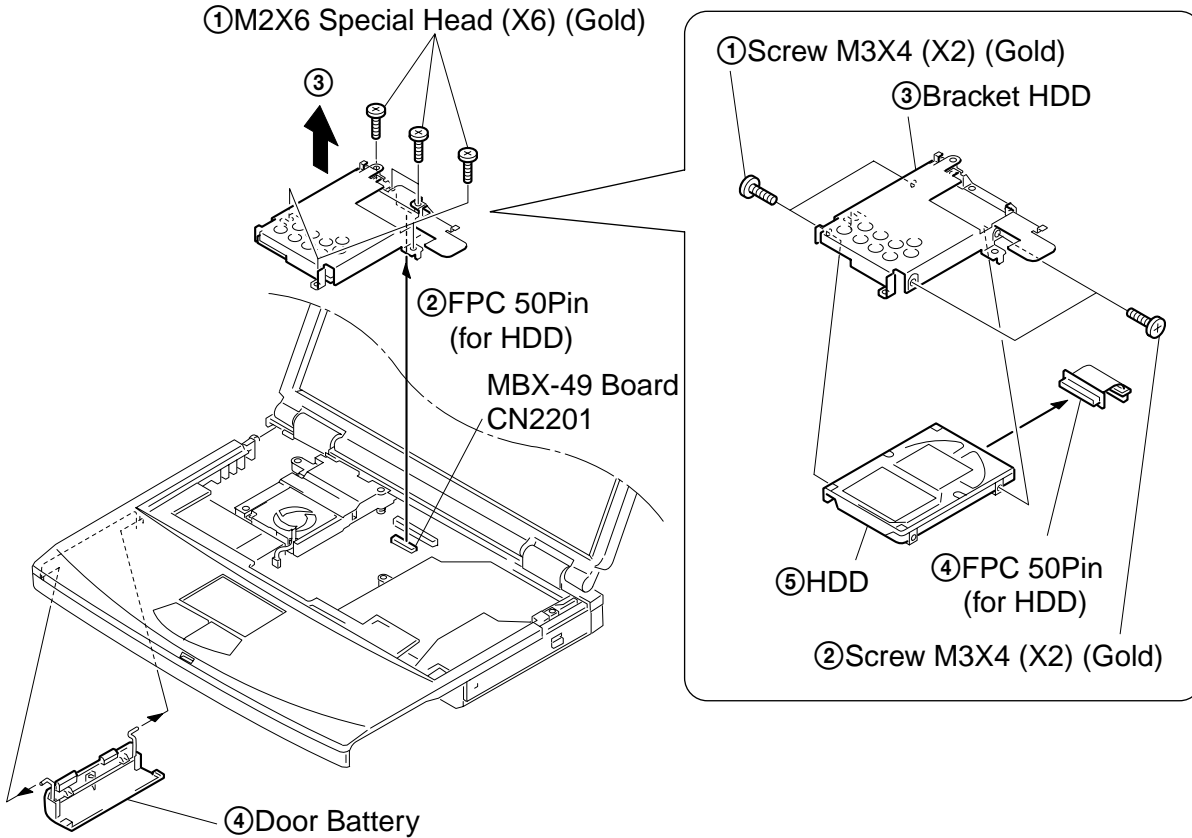

#### 5. Palm Rest Assy, Touch Pad, CNX-125 Board, Palm Rest Plate, Bracket Pad

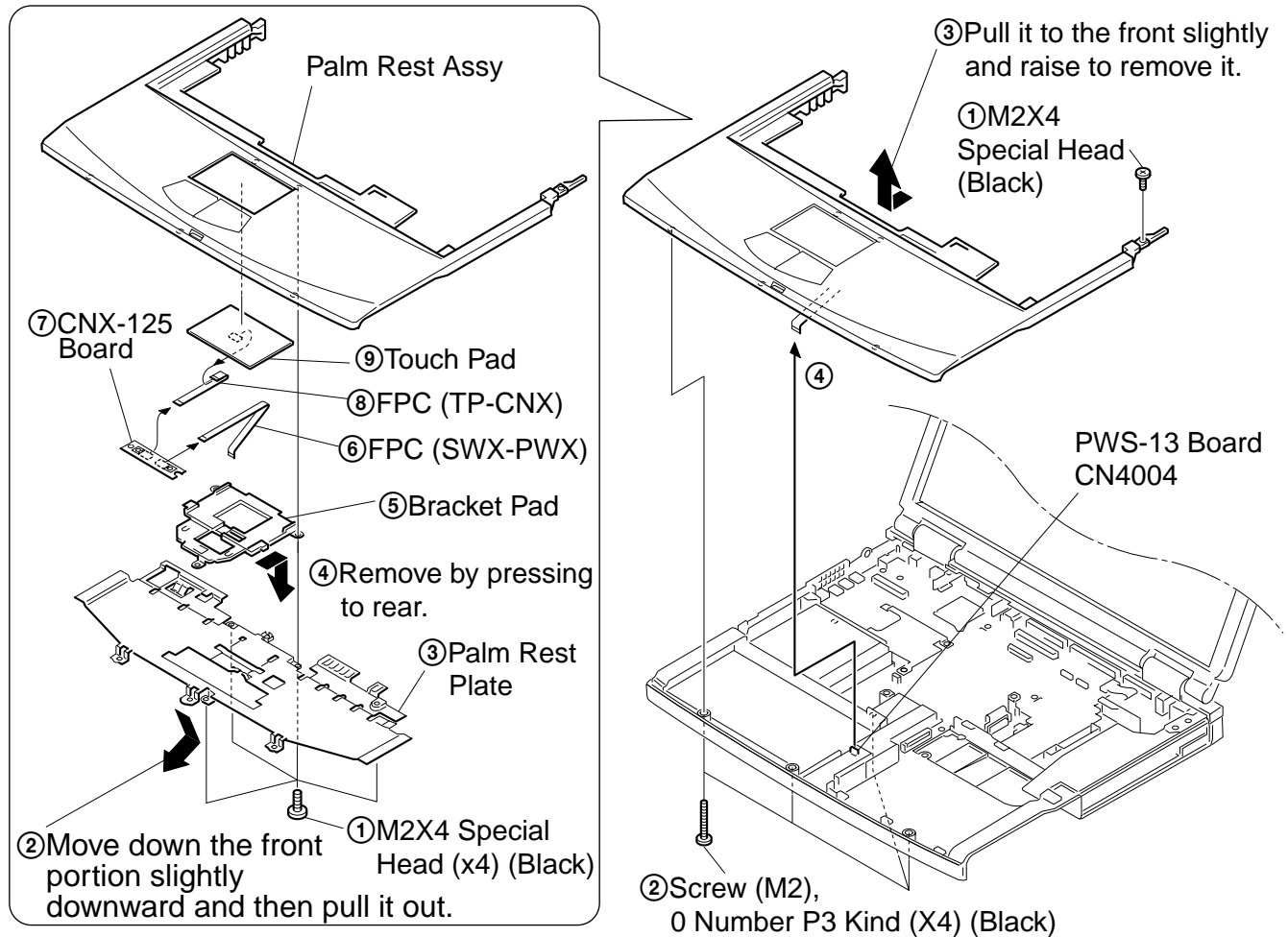

**Confidential**

## 6. Display Assy, Hinge Cover

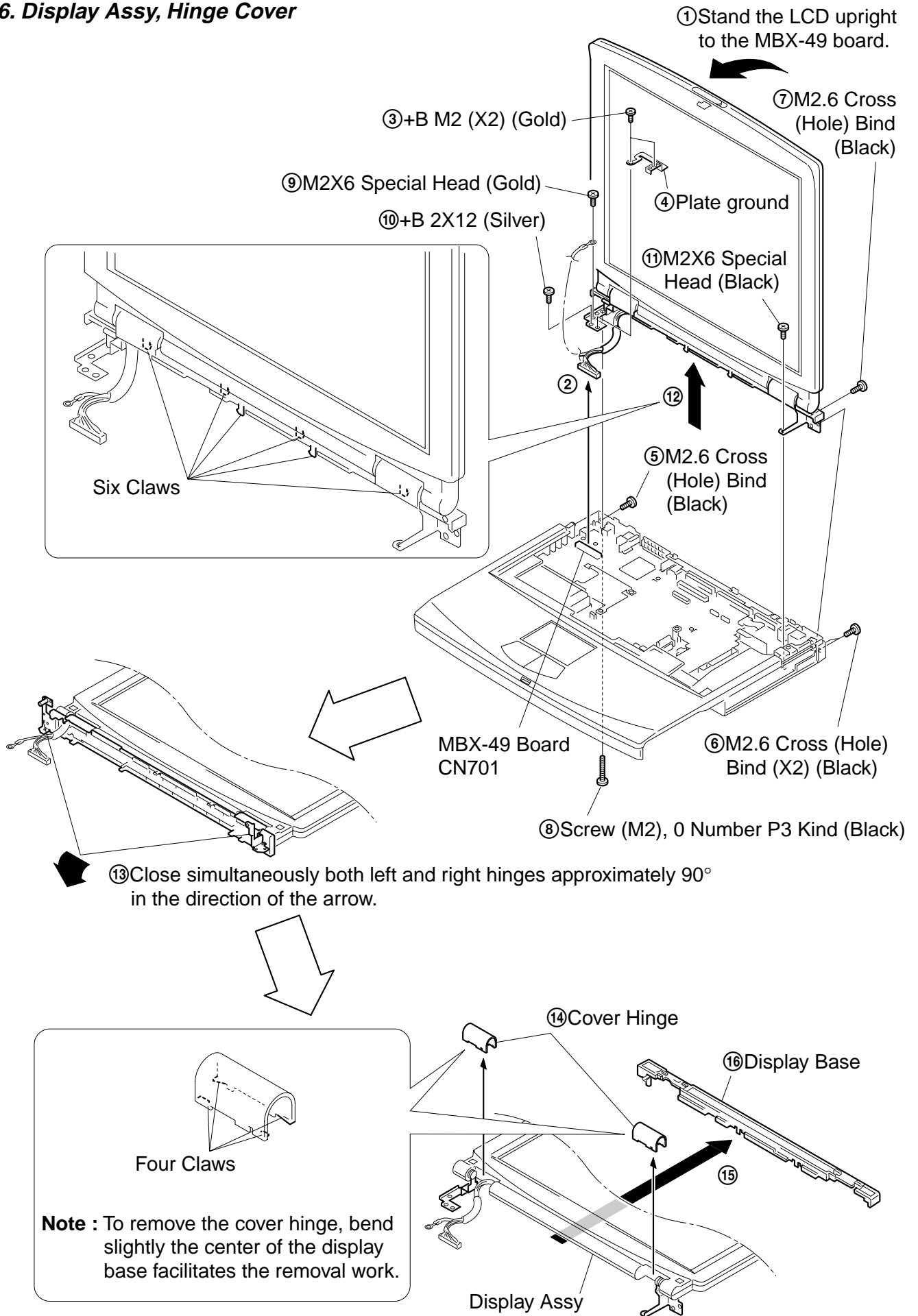

**Confidential**



## 7. PWS-13 Board, Latch Detector

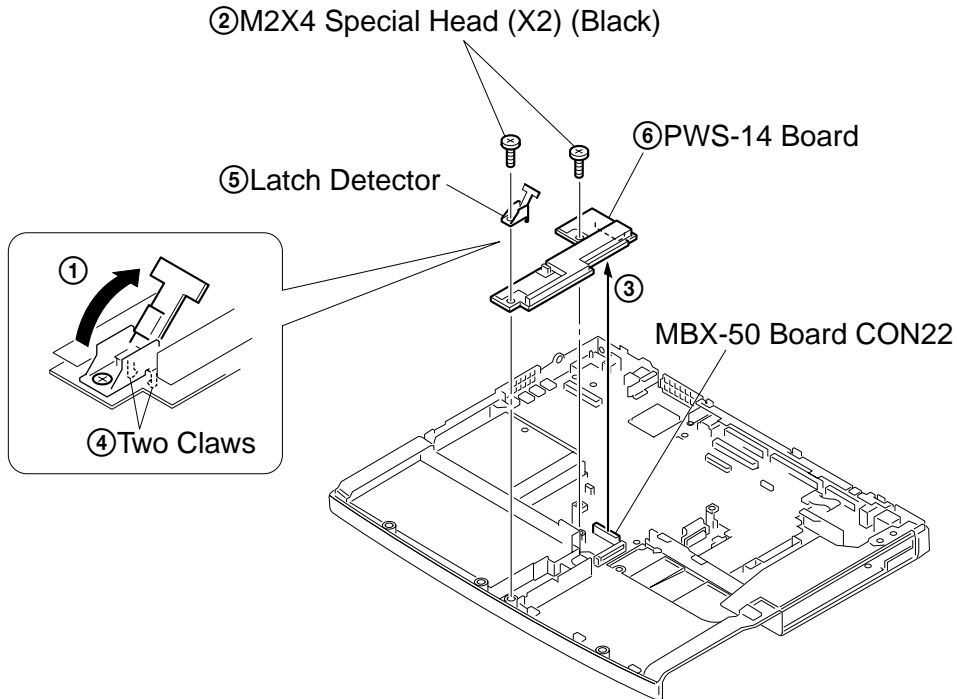

## 8. PC Card Connector, Modem Card, MBX-49 Board, I/O Bracket

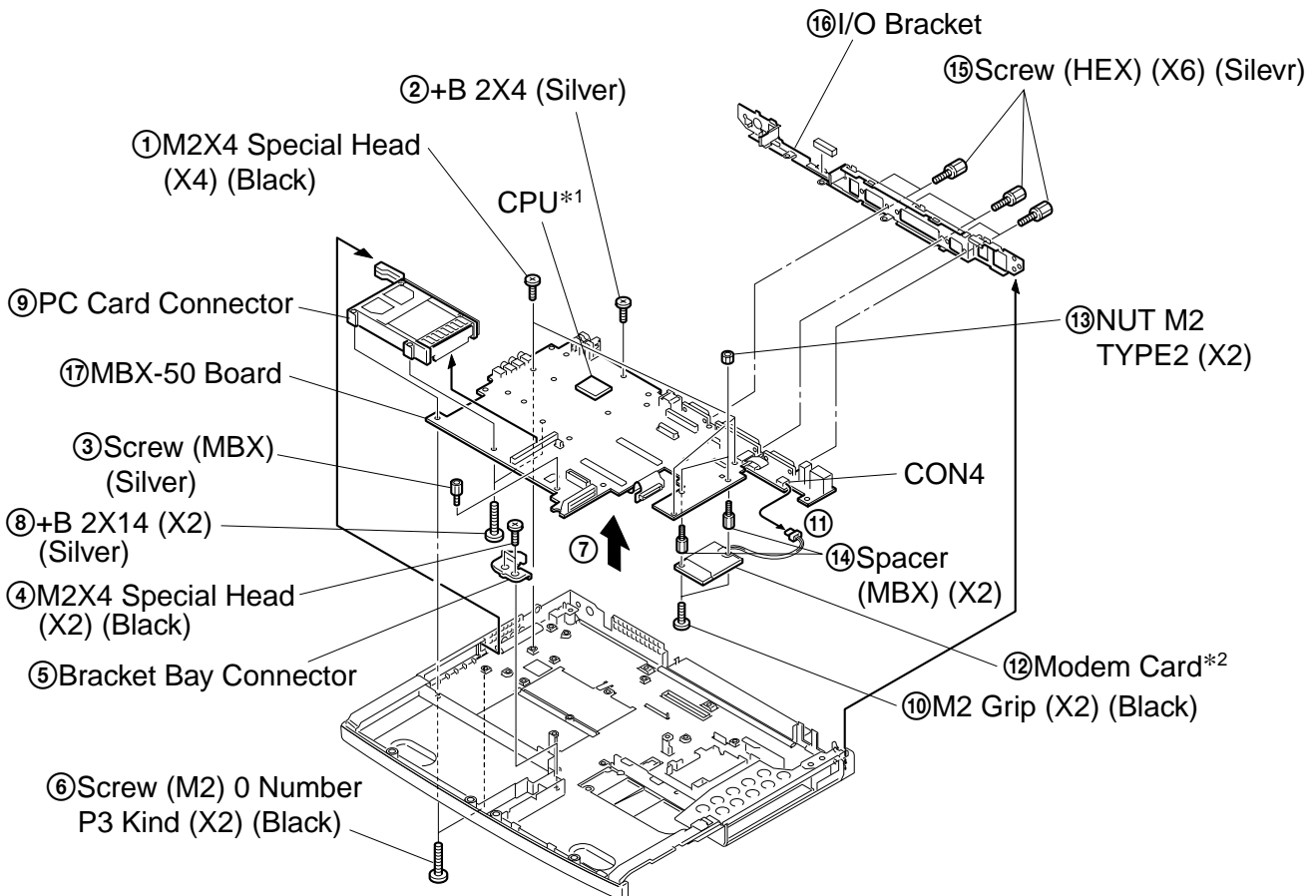

\*1 When removing the CPU, refer to " 1-4. Replacing the CPU ".

\*2 Modem card can be removed from the bottom.

Refer to the subsequent paragraph " 11. Modem card " for more details.

**Confidential**

## 9. Speaker Unit, SWX-73 Board

**Note :** When removing the speaker unit, be sure not to damage the hood keyboard.

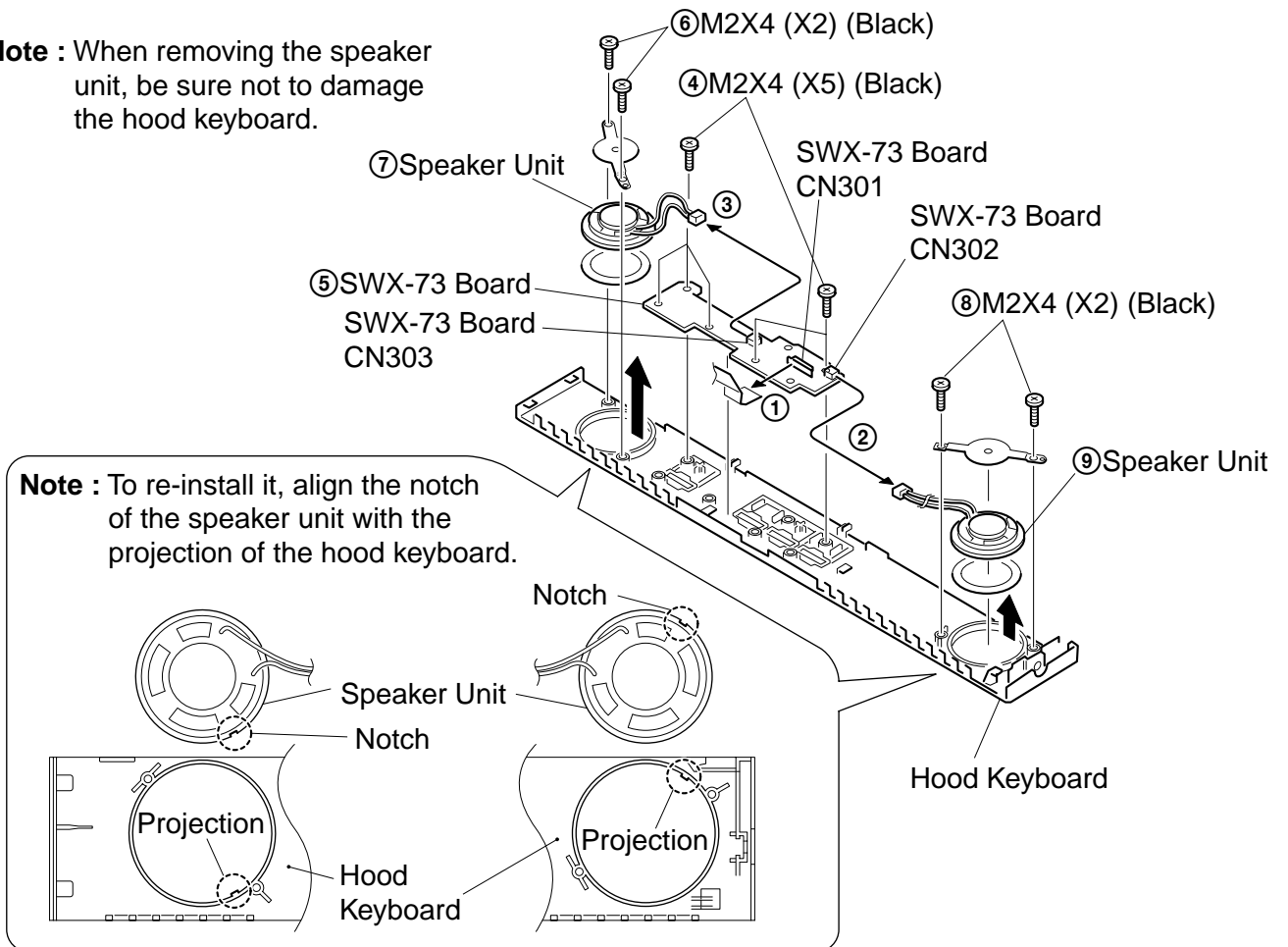

## 10. SO-DIMM

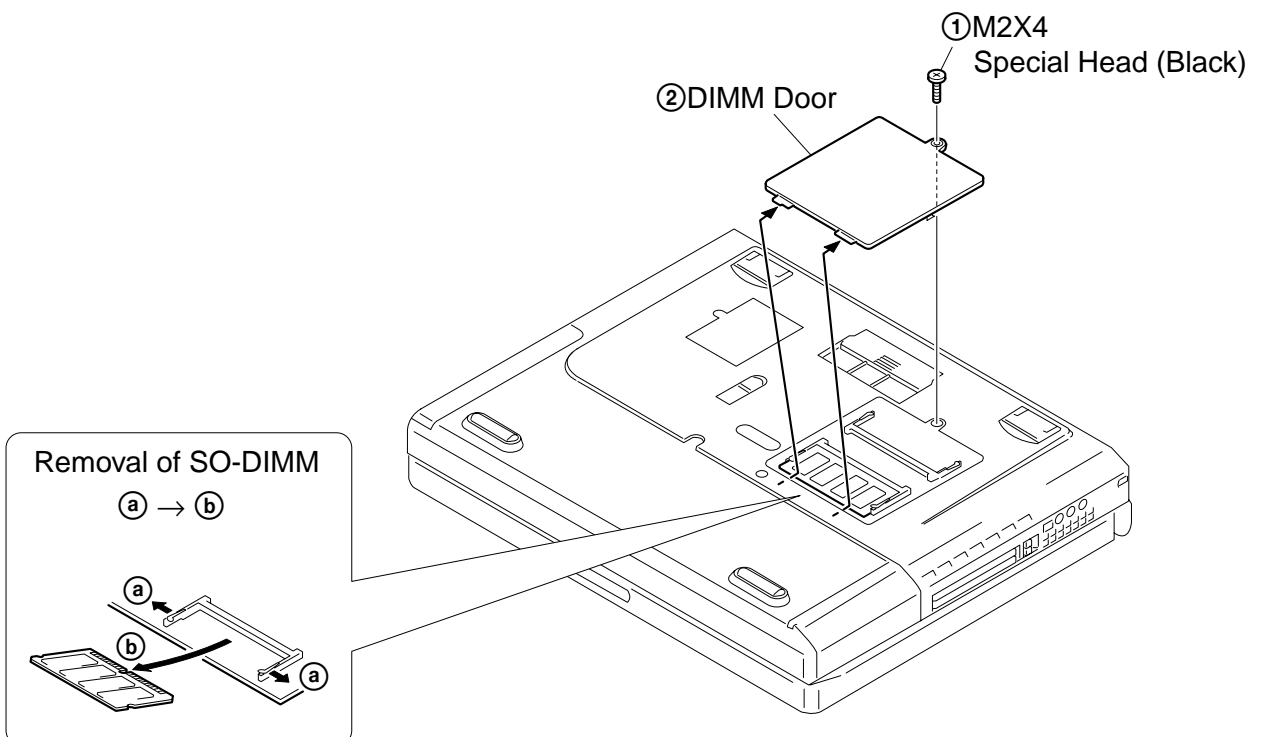

**Confidential**

## 11. Modem Card (Removing from the bottom)

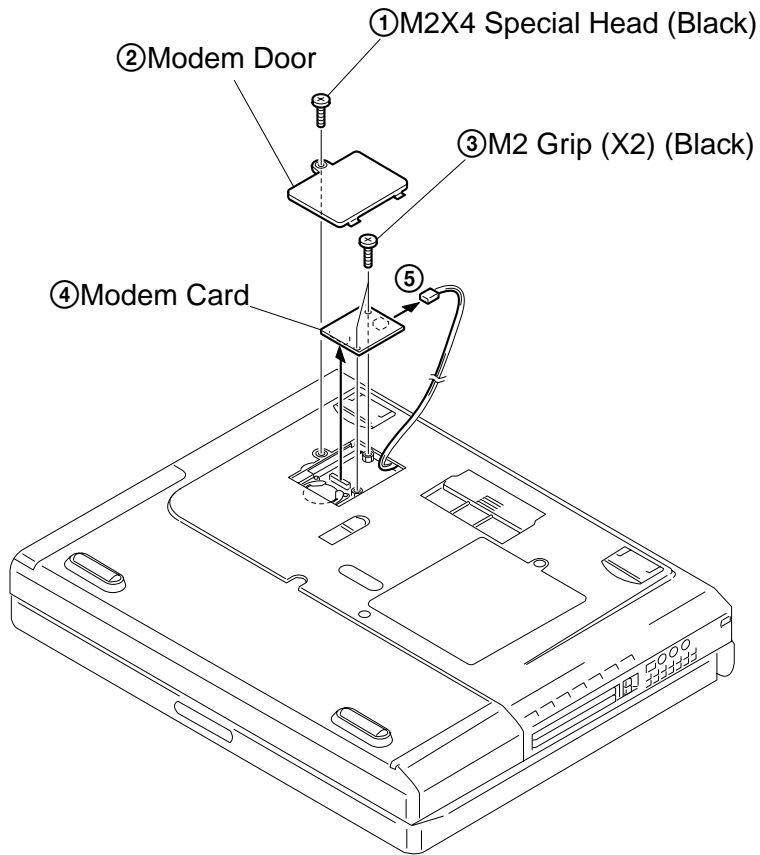

**Confidential**

**12. LCD Section (FX270/FX270K Model) – Made by HI –**

**1. Bezel Housing Assy, LCD unit (15 inch)**

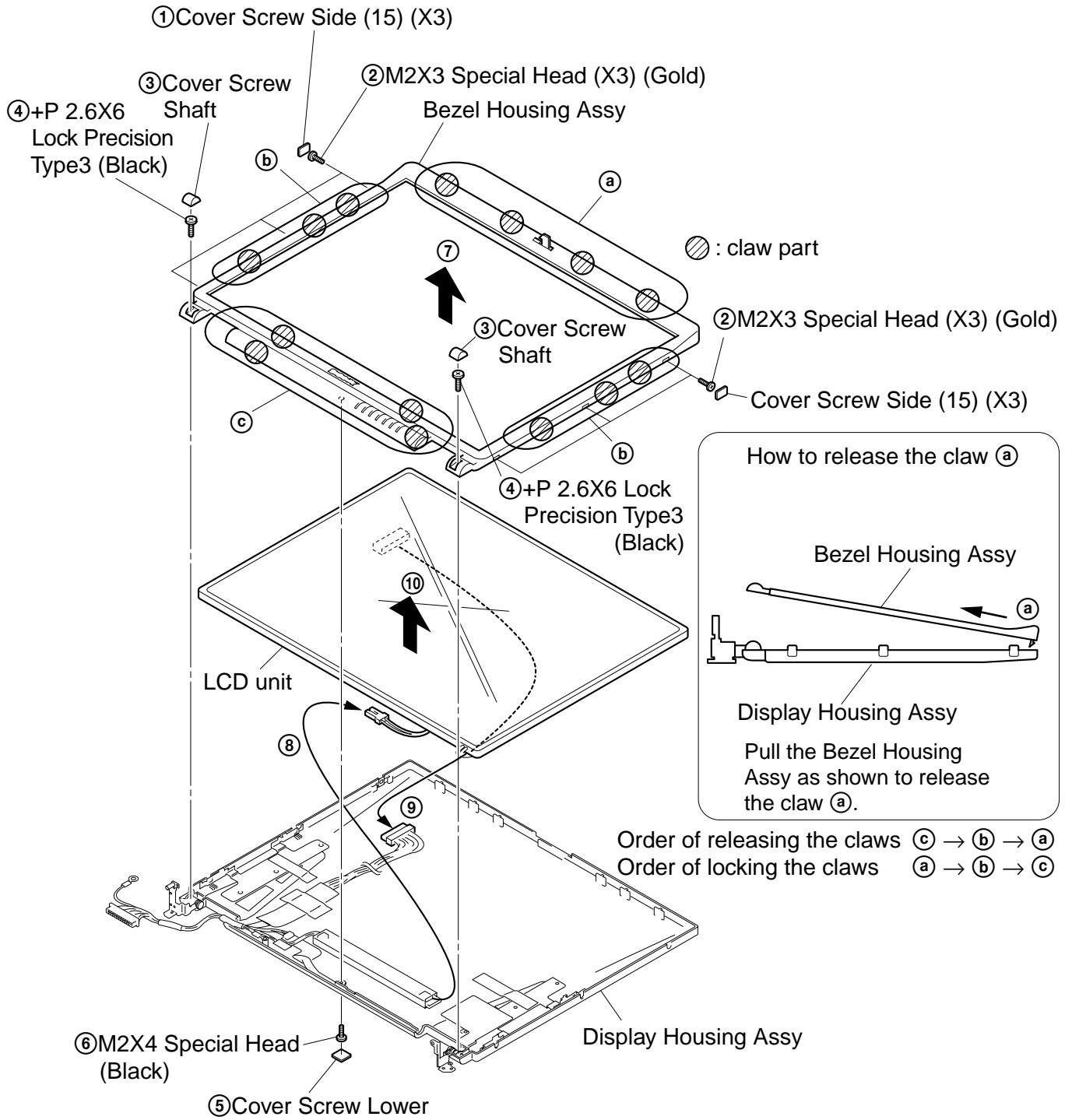

**Confidential**

## 2. Inverter Assy, LCD Harness, FPC, Display Hpusing Assy

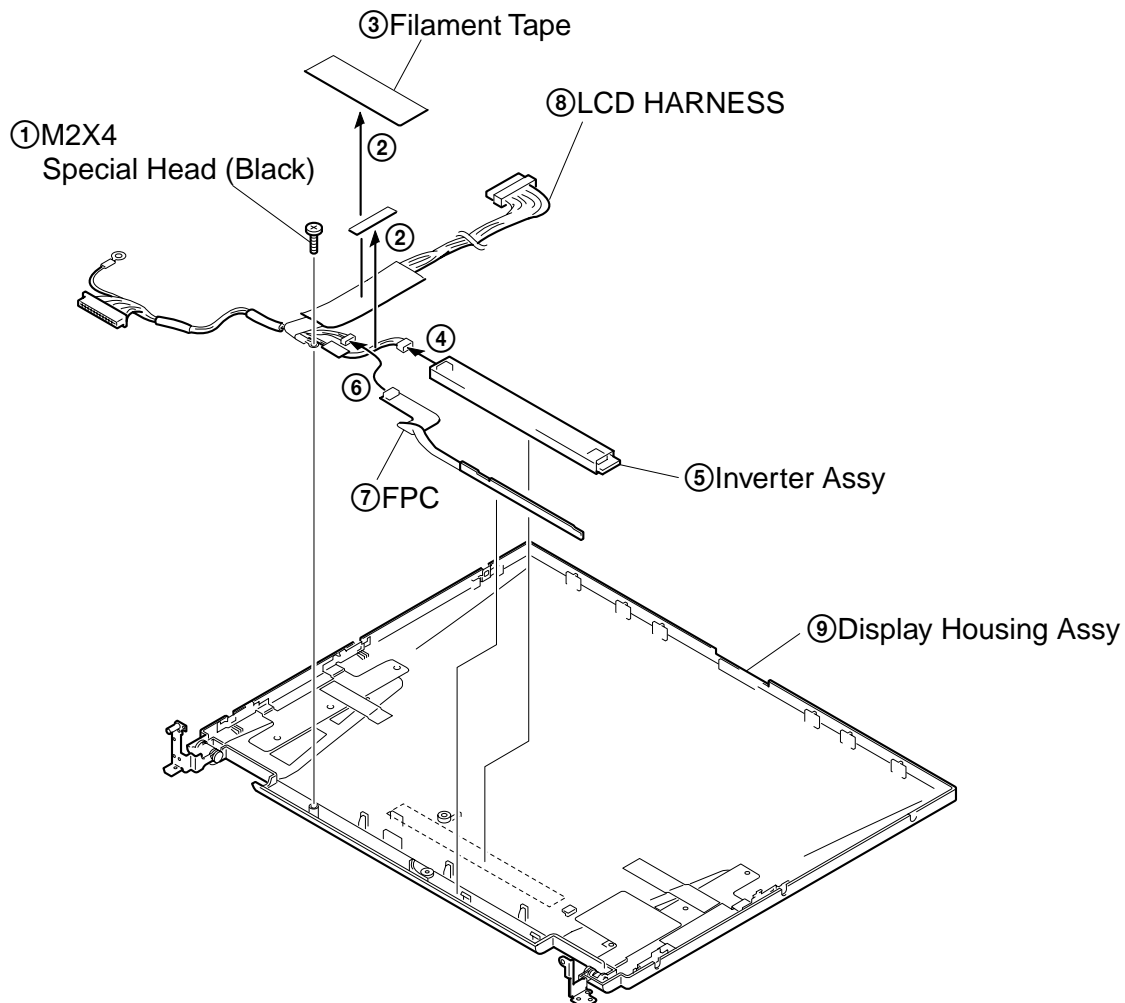

**Confidential**

**13. LCD Section (FX220/FX220K/FX250/FX250K Model) – Made by HI –**

**1. Bezel Housing Assy, LCD unit (15 inch)**

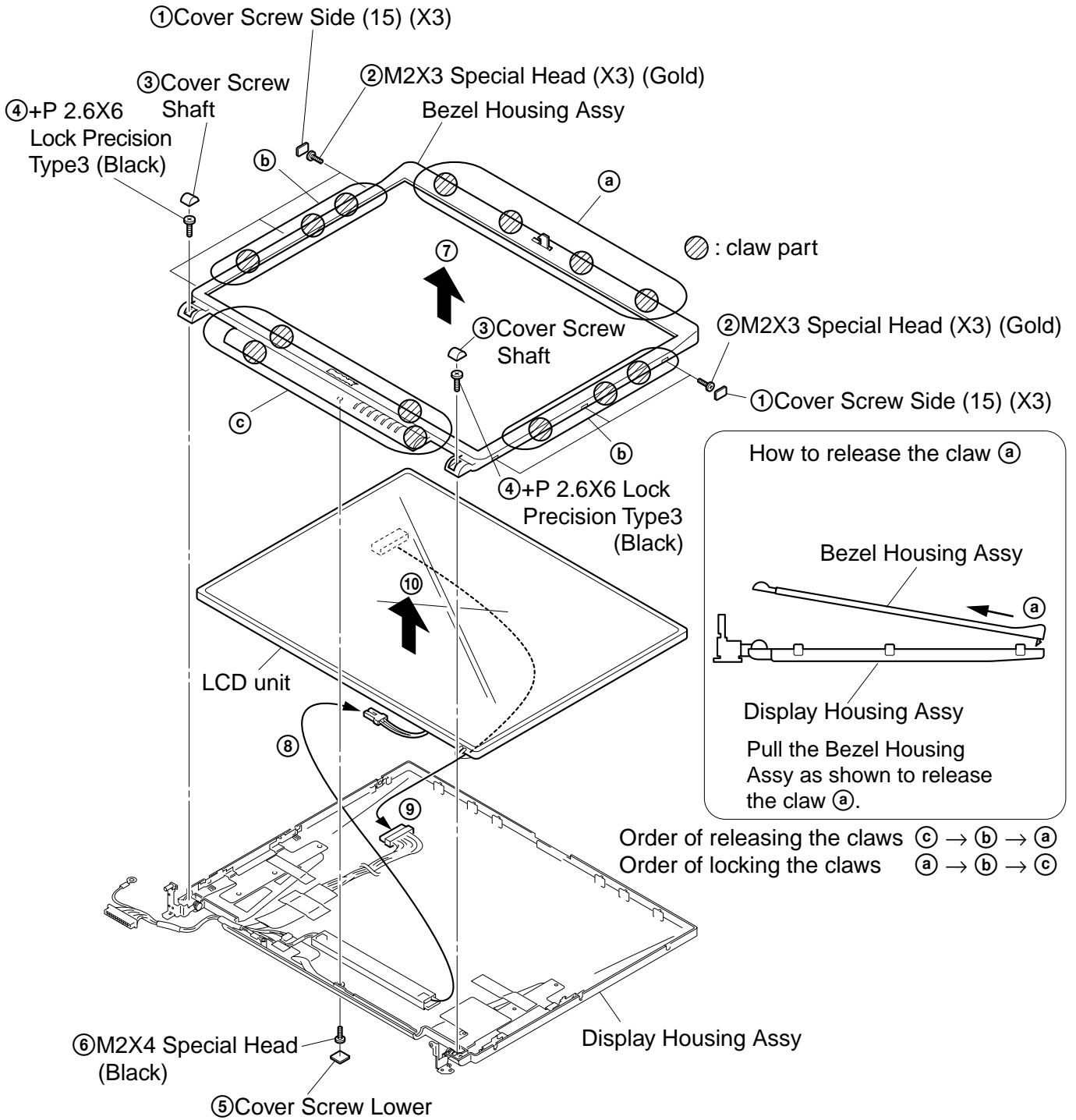

**Confidential**

## 2. Inverter Assy, LCD Harness, FPC, Display Hpusing Assy

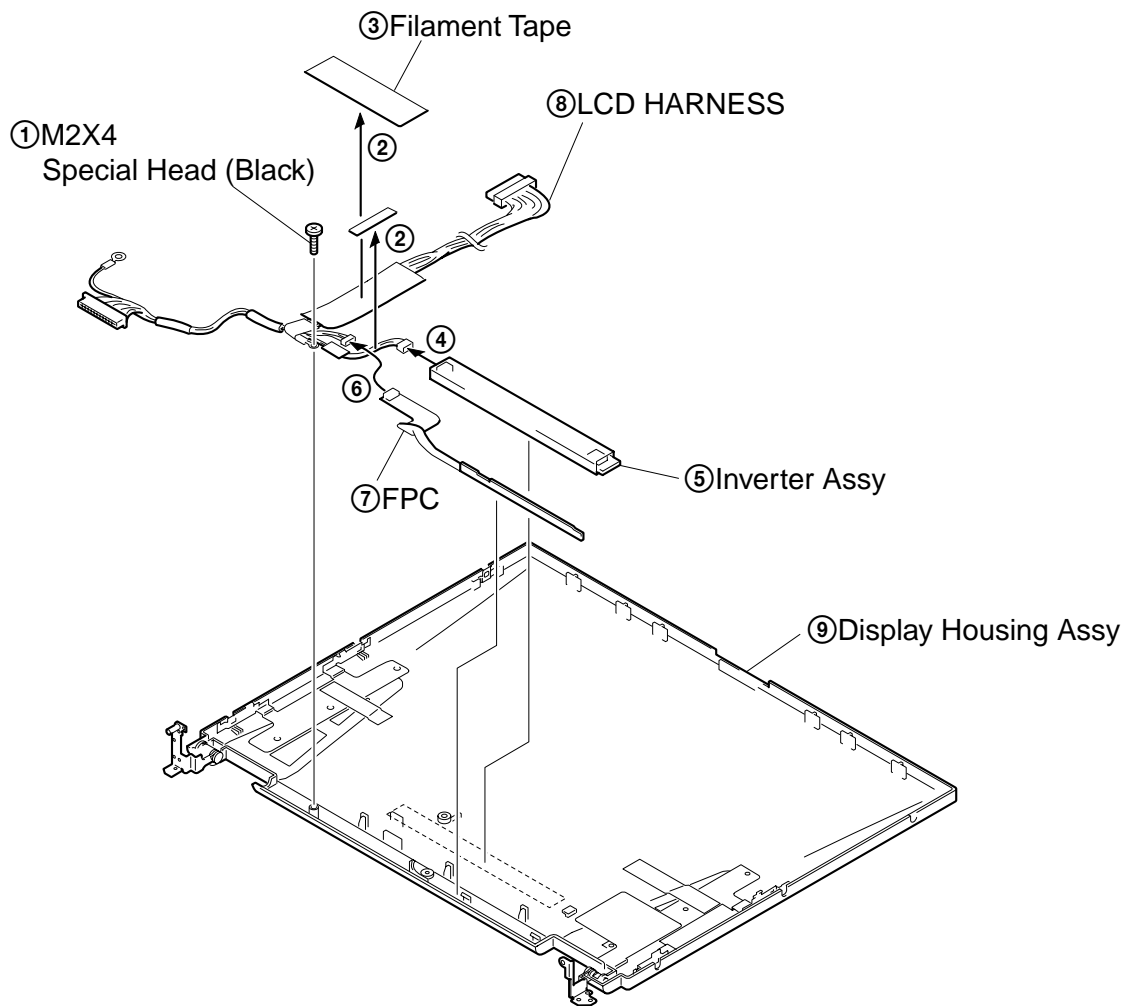

**Confidential**

**14. LCD Section (FX240/FX240K Model) – Made by HI –**  
**1. Bezel Housing Assy (14 inch)**

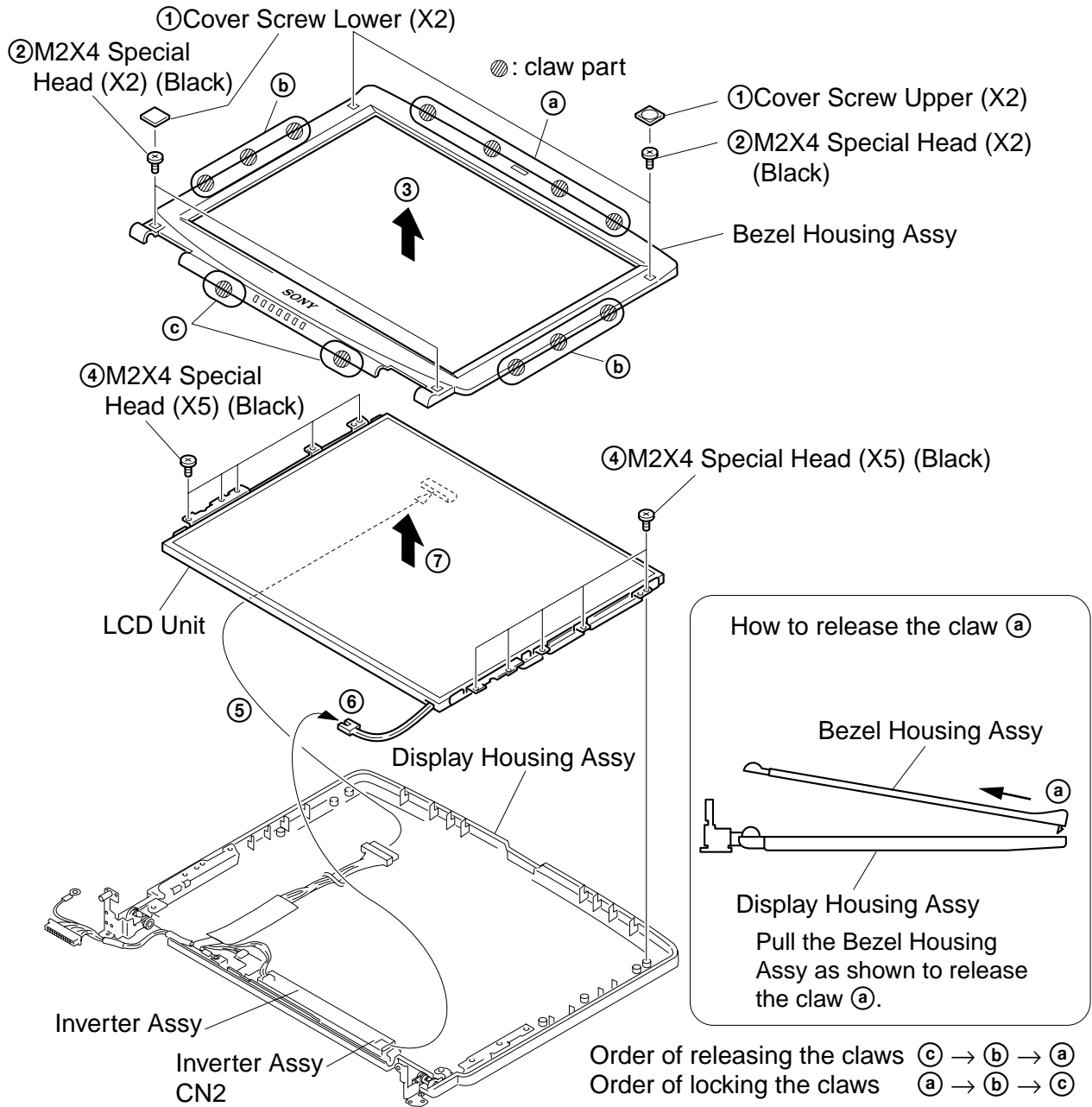

**Confidential**



## 2. Bracket LCD Left, Bracket LCD Right, LCD Unit (14 inch)

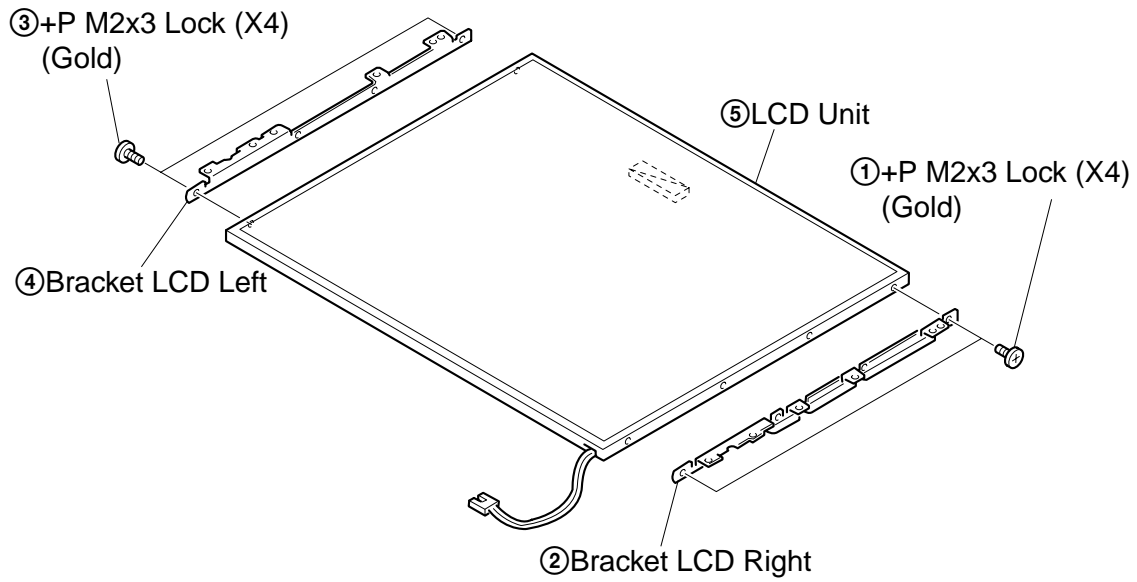

## 3. FPC, Inverter Assy, Display Housing Assy, LCD Harness

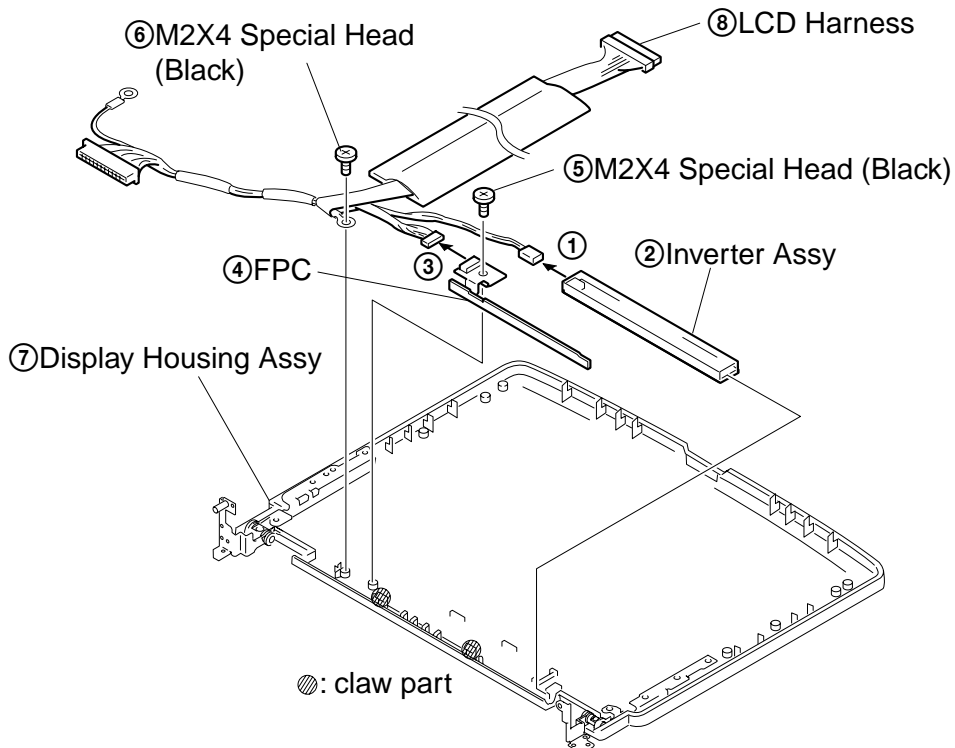

**Confidential**

# 1-4.Replacing the CPU

## NOTE:

This computer uses either one of the two types of CPU socket.

The CPU locking position and the lock-release position are different depending on the types of the CPU socket.

## 1. Socket type 1, 2

### 1. Removing the CPU

- ① Insert a flat-blade screwdriver into the notch as shown in the illustration and rotate it so that the protrusion comes to the lock release position.
- ② Pull the CPU gently upward to lift it out of the CPU socket.

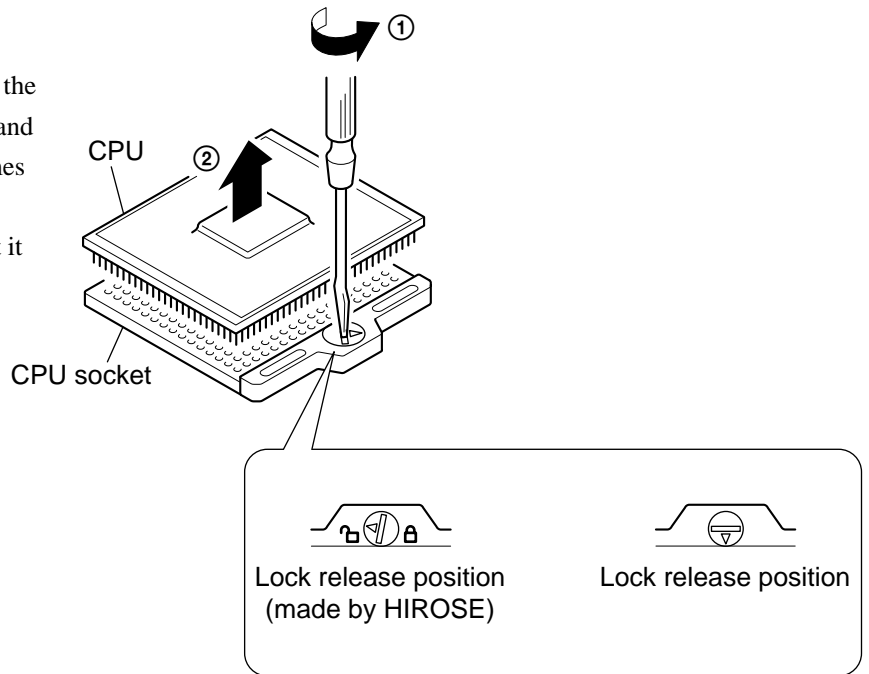

### 2. Installing the CPU

- ① Align the triangle reference mark of the CPU with that of the CPU socket and insert all the pins of the CPU to the corresponding holes of the CPU socket.
- ② Insert a flat-blade screwdriver into the notch as shown in the illustration and rotate it so that the protrusion comes to the lock position.

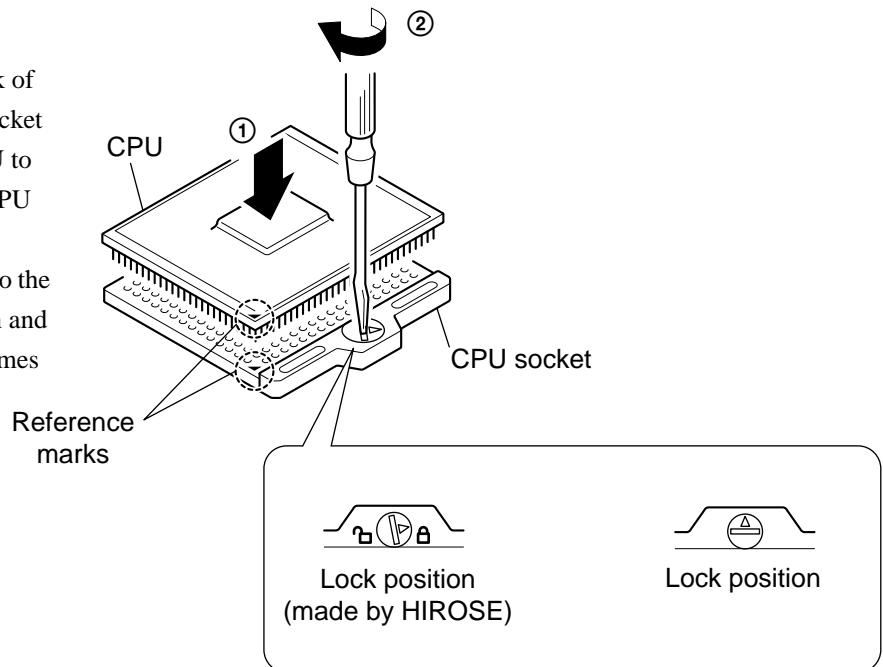

## NOTE:

Rotate a flat-blade screwdriver to the lock position securely. If not, the operation of the CPU may become unstable.

## 2. Socket type 3

### 1. Removing the CPU

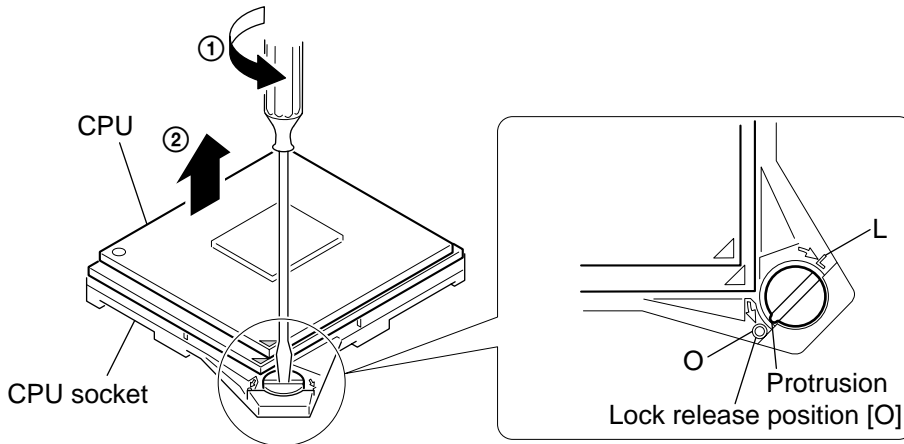

- ① Insert a flat-blade screwdriver into the notch as shown in the illustration and rotate it so that the protrusion comes to the “O” (lock release) position.
- ② Pull the CPU gently upward to lift it out of the CPU socket.

### 2. Installing the CPU

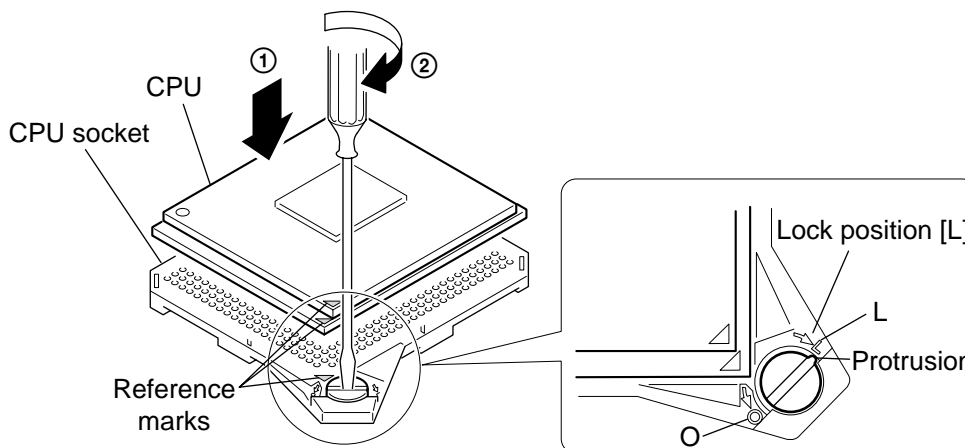

- ① Align the triangle reference mark of the CPU with that of the CPU socket and insert all the pins of the CPU to the corresponding holes of the CPU socket.
- ② Insert a flat-blade screwdriver into the notch as shown in the illustration and rotate it so that the protrusion comes to the “L” (lock) position.

#### NOTE:

- Considerable force is required to rotate a flat-blade screwdriver.
- Rotate a flat-blade screwdriver to the “L” (lock) position securely. If not, the operation of the CPU may become unstable.

**Confidential**

## 1-5. Replacing Various Connectors on the MBX-49 Board

Replace the connectors of “5-5. Connector Section” as follows.

### 1. Removing the I/O Bracket

When removing the connectors of reference numbers 164, 165 and 167 (refer to page 5-13), remove the I/O bracket first.

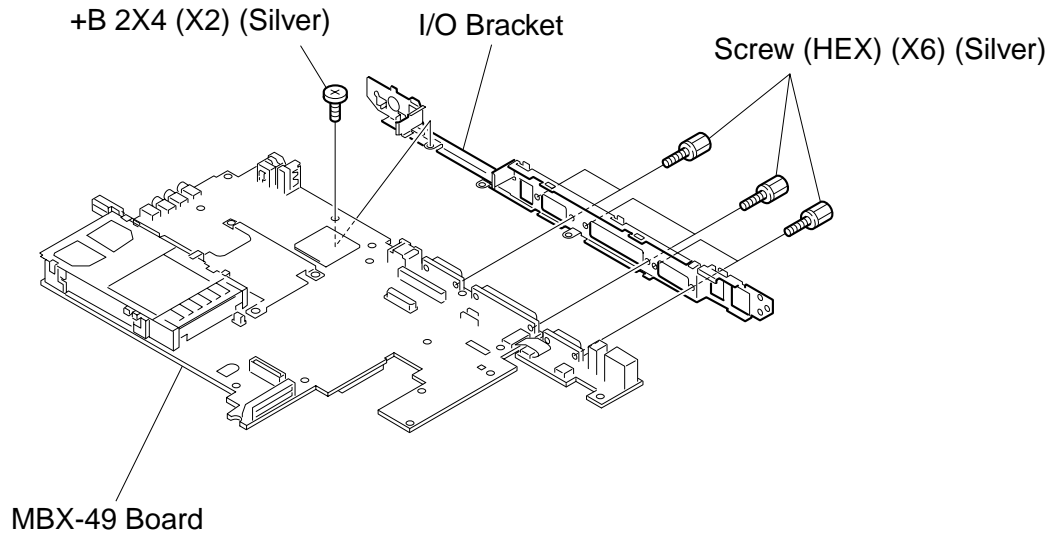

### 2. Removing the Various Connectors

The connectors of reference numbers 164, 165 and 167 (Refer to page 5-13, 5-14) are connected by soldering, remove the soldering first then remove the connectors.

## 1-6. DIP Switch Setting of the MBX-49 Board

Set the DIP switch on the MBX-49 board (main board) to match with the LCD that is used in this computer, because several types of LCD are used as shown in the following table and the DIP switch setting differs depending on the LCD type.

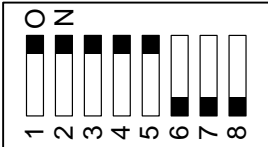
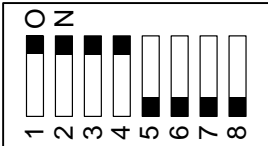
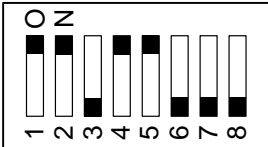
| MODEL                        | Name of LCD | Part No.     | DIP switch setting  |     |   |   |   |   |   |   |   |   |        |   |   |   |   |   |   |   |   |
|------------------------------|-------------|--------------|---|-----|---|---|---|---|---|---|---|---|--------|---|---|---|---|---|---|---|---|
| FX270/FX270K                 | HI          | 1-476-300-11 |  <p>The upper position where ON indication is shown is the ON position. The lower position is the OFF position.</p> <table border="1"> <thead> <tr> <th>No.</th> <th>1</th> <th>2</th> <th>3</th> <th>4</th> <th>5</th> <th>6</th> <th>7</th> <th>8</th> </tr> </thead> <tbody> <tr> <td>ON/OFF</td> <td>0</td> <td>0</td> <td>0</td> <td>0</td> <td>0</td> <td>1</td> <td>1</td> <td>1</td> </tr> </tbody> </table> <p>0 : ON 1: OFF</p>   | No. | 1 | 2 | 3 | 4 | 5 | 6 | 7 | 8 | ON/OFF | 0 | 0 | 0 | 0 | 0 | 1 | 1 | 1 |
| No.                          | 1           | 2            | 3   | 4   | 5 | 6 | 7 | 8 |   |   |   |   |        |   |   |   |   |   |   |   |   |
| ON/OFF                       | 0           | 0            | 0   | 0   | 0 | 1 | 1 | 1 |   |   |   |   |        |   |   |   |   |   |   |   |   |
| FX220/FX220K<br>FX250/FX250K | HI          | 1-476-186-12 |  <p>The upper position where ON indication is shown is the ON position. The lower position is the OFF position.</p> <table border="1"> <thead> <tr> <th>No.</th> <th>1</th> <th>2</th> <th>3</th> <th>4</th> <th>5</th> <th>6</th> <th>7</th> <th>8</th> </tr> </thead> <tbody> <tr> <td>ON/OFF</td> <td>0</td> <td>0</td> <td>0</td> <td>0</td> <td>1</td> <td>1</td> <td>1</td> <td>1</td> </tr> </tbody> </table> <p>0 : ON 1: OFF</p>  | No. | 1 | 2 | 3 | 4 | 5 | 6 | 7 | 8 | ON/OFF | 0 | 0 | 0 | 0 | 1 | 1 | 1 | 1 |
| No.                          | 1           | 2            | 3   | 4   | 5 | 6 | 7 | 8 |   |   |   |   |        |   |   |   |   |   |   |   |   |
| ON/OFF                       | 0           | 0            | 0   | 0   | 1 | 1 | 1 | 1 |   |   |   |   |        |   |   |   |   |   |   |   |   |
| FX240/FX240K                 | HI          | 1-476-789-11 |  <p>The upper position where ON indication is shown is the ON position. The lower position is the OFF position.</p> <table border="1"> <thead> <tr> <th>No.</th> <th>1</th> <th>2</th> <th>3</th> <th>4</th> <th>5</th> <th>6</th> <th>7</th> <th>8</th> </tr> </thead> <tbody> <tr> <td>ON/OFF</td> <td>0</td> <td>0</td> <td>1</td> <td>0</td> <td>0</td> <td>1</td> <td>1</td> <td>1</td> </tr> </tbody> </table> <p>0 : ON 1: OFF</p> | No. | 1 | 2 | 3 | 4 | 5 | 6 | 7 | 8 | ON/OFF | 0 | 0 | 1 | 0 | 0 | 1 | 1 | 1 |
| No.                          | 1           | 2            | 3   | 4   | 5 | 6 | 7 | 8 |   |   |   |   |        |   |   |   |   |   |   |   |   |
| ON/OFF                       | 0           | 0            | 1   | 0   | 0 | 1 | 1 | 1 |   |   |   |   |        |   |   |   |   |   |   |   |   |

**Confidential**

## **CHAPTER 2.**

# **SELF DIAGNOSTICS**

---

### **ATTENTION**

Please confirm “Self Diagnostics” method which will be informed you with distribution of “Self Diagnostics” software.

**Confidential**



# CHAPTER 4. FRAME HARNESS DIAGRAM

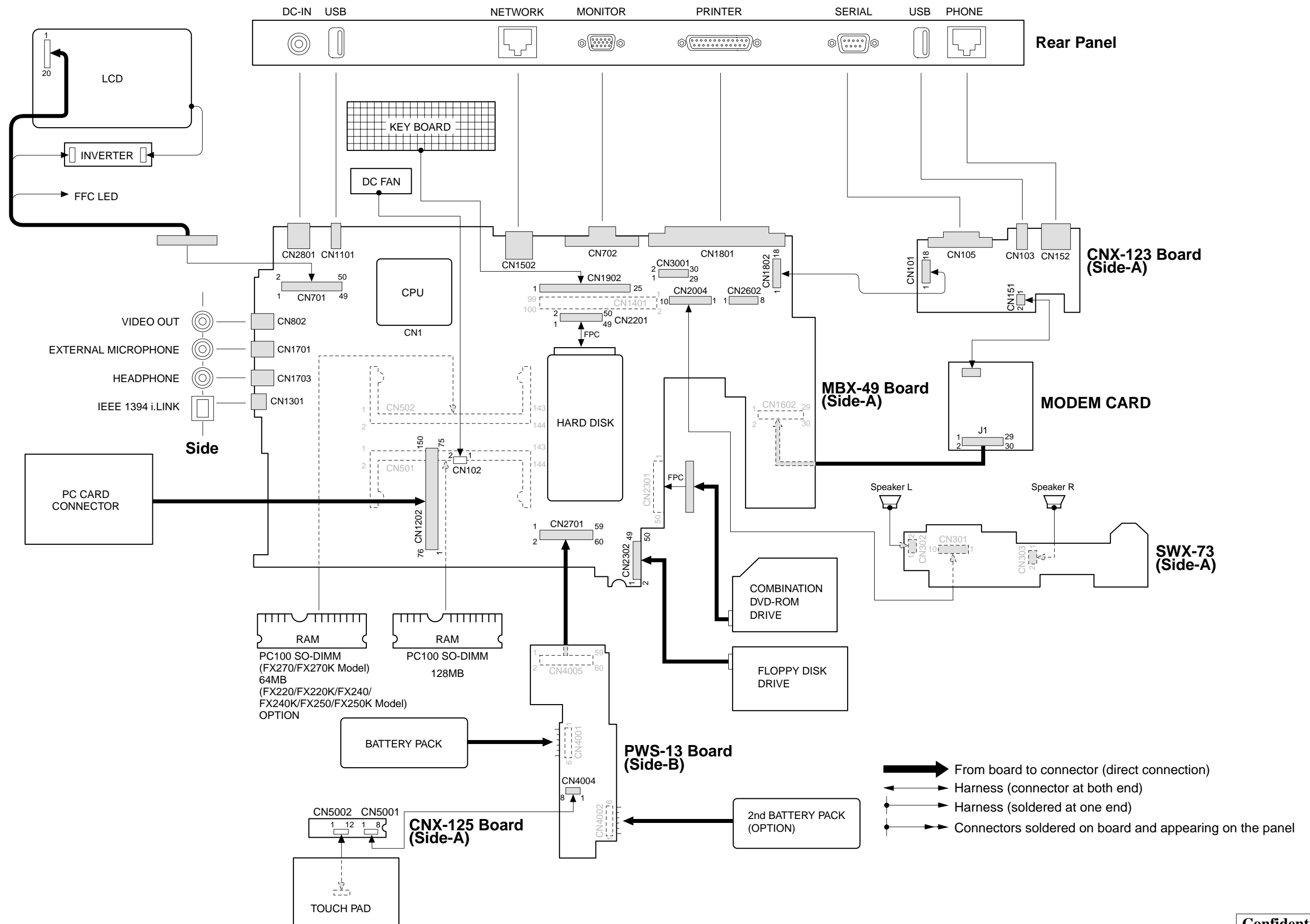



# CHAPTER 5.

## EXPLODED VIEWS AND PARTS LIST

**NOTE:**

- The mechanical parts with no reference number in the exploded views are not supplied.
- Items marked “ \* ” are not stocked since they are seldom required for routine service. Some delay should be anticipated when ordering these items.
- When two or more parts are shown in parallel, use the part described first as the main part.

The components identified by mark  $\Delta$  or dotted line with mark  $\Delta$  are critical for safety. Replace only with part number specified.

Les composants identifiés par une marque  $\Delta$  sont critiques pour la sécurité. Ne les remplacer que par une pièce portant le numéro spécifié.

### How to use properly the repair parts.

There are some parts that use the 2 types ; the [CH] parts or alternately the [JP] parts, in this series. Use the [CH] repair parts for the [CH] type product, vice versa.

[ How to identify the parts ]

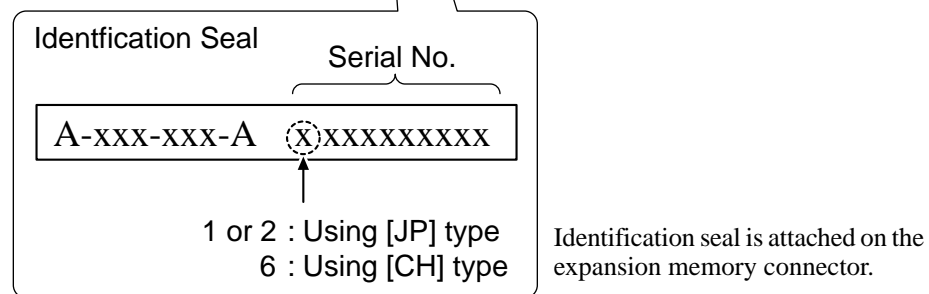
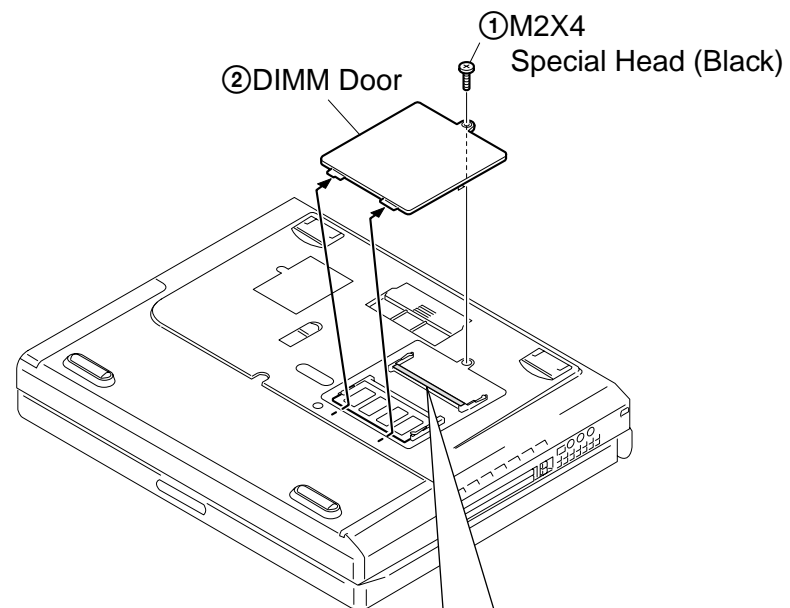

[ Repair part description example ]

| Ref.No. | Part No.     | Description                 |
|---------|--------------|-----------------------------|
| 999     | A-8025-235-A | (CH)...MBX-49 (CH) ASSY (S) |
| 999     | 4-8025-236-A | (JP)...MBX-49 (JP) ASSY (S) |

## 5-1. Main Section

| Ref.No. | Part No.     | Description  | Ref.No. | Part No.     | Description   | Ref.No. | Part No.     | Description                     |
|---------|--------------|--|---------|--------------|---|---------|--------------|---------------------------------|
| 1       | X-4623-780-1 | ASSY BOTTOM (AM2)  | 71      | 4-641-851-02 | SPRING (FDD), PLATE   | B1      | 4-641-726-41 | SCREW (M2), SPECIAL HEAD        |
| 3       | 4-640-837-31 | DOOR BATTERY   | 72      | 4-651-709-41 | (CH)...BRACKET IO   | B3      | 4-644-899-01 | SCREW (M2), 0 NUMBER P3 KIND    |
| 3       | 4-640-837-22 | DOOR BATTERY   | 72      | 4-651-709-01 | (JP)...BRACKET IO   | B4      | 4-639-112-01 | SCREW M2X4                      |
| * 8     | 4-651-706-21 | HEATSINK BOTTOM  | 74      | 4-651-702-11 | DOOR DIMM   | B6      | 4-646-807-01 | 0 PLATE M2.5 (FDD)              |
| * 8     | 4-651-706-01 | HEATSINK BOTTOM  | * 76    | 4-644-361-01 | BRACKET SPK   | B7      | 4-644-402-12 | SCREW (MBX)                     |
| * 11    | 4-651-707-11 | INSULATOR HEATSINK BOTTOM  | * 78    | 4-644-362-21 | PLATE PALMREST  | B10     | 4-652-498-01 | +B M2 (NOJI)                    |
| * 11    | 4-651-707-21 | INSULATOR HEATSINK BOTTOM  | * 78    | 4-644-362-11 | PLATE PALMREST  | B12     | 4-645-177-01 | SCREW (M1.7X3.5)                |
| 12      | 1-763-658-21 | FAN, DC (WITH HEAT SINK)   | 81      | 8-749-019-00 | IC HYM71V16M655AT6-P<br>(PC-100 SO-DIMM (128MB CL2))                      | B14     | 4-645-497-01 | SCREW (M2.6), CROSS (HOLE) BIND |
| 15      | 4-643-832-31 | DUMMY CARD   | 81      | 8-749-019-29 | IC MC-4516CD641PS-A80<br>(PC-100 SO-DIMM (128MB CL2))                     | B15     | 4-635-301-01 | SCREW M3X4                      |
| 15      | 4-643-832-21 | DUMMY CARD   | 82      | 8-749-018-97 | (FX270/FX270K)...<br>IC HYM71V8M655AT6-P<br>(PC-100 SO-DIMM (64MB CL2))   | B18     | 4-635-966-01 | SCREW (HEX)                     |
| 18      | A-8025-266-A | SWX-73 (CH) ASSY (S)   | 82      | 8-759-695-59 | (FX270/FX270K)...<br>IC MT4LSDT864HG-10EB1<br>(PC-100 SO-DIMM (64MB CL2)) | B31     | 4-645-214-11 | GRIP, M2                        |
| 18      | A-8066-695-A | COMPLETE PWB SWX-73CH  | 84      | 1-960-827-21 | HARNES (2 PIN)  | B32     | 7-621-772-68 | SCREW +B 2X12                   |
| 19      | X-4623-388-2 | ASSY HOOD KEYBOARD (Z)   | 88      | A-8025-235-A | (CH)...MBX-49 (CH) ASSY (S)   | B33     | 4-642-852-21 | +B M2                           |
| 20      | 1-529-287-11 | SPEAKER UNIT   | 88      | A-8025-236-A | (JP)...MBX-49 (JP) ASSY (S)   | B34     | 4-641-726-11 | SCREW (M2), SPECIAL HEAD        |
| 21      | 3-718-233-01 | NUT, PLATE   | 105     | 4-641-630-11 | COVER BAY HOLE  | B35     | 7-621-772-70 | SCREW +B 2X14                   |
| 22      | 1-790-639-22 | FPC 50PIN (FOR HDD)  | 112     | 1-815-505-12 | CONNECTOR, 2 SLOT CARD BUS  | B36     | 7-622-205-05 | NUT (M2 TYPE2), HEXAGON         |
| 24      | 1-772-727-11 | (FX250/FX250K/FX270/FX270K)...<br>HDD (DJSA-220 20.0GB)                      | 123     | 1-790-711-21 | FFC (PPK)   | B37     | 4-650-481-01 | SCREW (B1.7), TAPPING           |
| 24      | 1-796-187-11 | (FX220/FX220K/FX240/FX240K)...<br>HDD (15.0GB)-DJSA220                       | 124     | 1-757-767-11 | FFC (TP-CNX)  |         |              |                                 |
| 25      | 1-476-647-12 | KEY BOARD UNIT (US)  | 125     | 1-790-710-11 | FFC (SWX-PWS)   |         |              |                                 |
| 26      | X-4623-390-1 | ASSY PALMREST  | 126     | 4-644-053-01 | SPACER FDD  |         |              |                                 |
| 27      | 1-772-529-72 | PAD, TOUCH   | * 128   | 4-653-452-01 | PLATE, GROUND   |         |              |                                 |
| 28      | A-8025-267-A | CNX-125 (CH) ASSY (S)  | * 134   | 4-645-433-01 | BRACKET BAY CONNECTOR   |         |              |                                 |
| 28      | A-8066-693-A | COMPLETE PWB CNX-125CH   | 136     | 4-644-357-01 | CUSHION SPK   |         |              |                                 |
| 29      | 4-651-699-01 | BRACKET PAD  | 139     | A-8048-966-A | ASSY BAY FD (TE)  |         |              |                                 |
| * 30    | 4-651-708-21 | BRACKET (HDD)  | 147     | 6-700-620-01 | (FX220/FX220K)...<br>IC KP80526GY750256-2 (PIII 750 MHz)                  |         |              |                                 |
| 31      | 4-640-861-11 | BRACKET CD-ROM R   | 147     | 6-700-619-01 | (FX240/FX240K/FX250/FX250K)...<br>IC KP80526GY800256-2 (PIII 800 MHz)     |         |              |                                 |
| 32      | 1-796-171-11 | (FX220/FX220K)...<br>DVD-ROM DRIVE (SDR-081)                                 | 147     | 6-700-618-01 | (FX270/FX270K)...<br>IC KP80526GY850256-2 (PIII 850 MHz)                  |         |              |                                 |
| 32      | 1-796-072-12 | (FX240/FX240K/FX250/<br>FX250K/FX270/FX270K)...<br>COMBO DRIVE (UJDA710)     | 148     | X-4623-561-2 | ASSY LATCH DETECTOR   |         |              |                                 |
| 33      | X-4623-749-1 | (FX220/FX220K)...<br>ASSY DOOR DVD-RW Q (EXP)                                | * 152   | 4-651-871-01 | HEAT SINK   |         |              |                                 |
| 33      | X-4623-442-1 | (FX240/FX240K/FX250/<br>FX250K/FX270/FX270K)...<br>ASSY DOOR DVD-RW PA (EXP) | 153     | 4-652-012-01 | SHEET, ELECTRIC HEAT  |         |              |                                 |
| 34      | 4-640-860-12 | BRACKET (CD-ROM L)   | 154     | 4-651-989-01 | SPACER (MBX)  |         |              |                                 |
| 35      | 4-640-828-01 | PLATE FDD  | 155     | 4-651-701-11 | DOOR MODEM  |         |              |                                 |
| 36      | 1-772-034-21 | FDD (FD-5HG-5760)  | 156     | 4-653-151-11 | SPACER (KBF)  |         |              |                                 |
| 37      | X-4623-528-1 | ASSY BOTTOM FDD Z (TCY2)   | 157     | 4-653-466-01 | CUSHION (HD-M)  |         |              |                                 |
| 38      | 4-651-713-11 | (CH)...DOOR (IO)   | 159     | 4-653-963-01 | SHIELD (CNX)  |         |              |                                 |
| 38      | 4-651-713-01 | (JP)...DOOR I/O  | 160     | 4-653-964-01 | SPACER (B/P)  |         |              |                                 |
| 39      | 4-651-844-01 | FOOT REAR  | 161     | 4-654-019-01 | GASKET (AV)   |         |              |                                 |
| 40      | 4-651-714-21 | DOOR DOCKING CONNECTOR   | 162     | 4-654-047-01 | SHIELD (AV)   |         |              |                                 |
| 41      | 4-640-851-11 | FOOT FRONT   | 163     | 4-653-936-01 | GASKET (HB/M)   |         |              |                                 |
| 46      | A-8025-233-A | (CH)...PWS-13 (CH) ASSY (S)  | 164     | 1-779-745-21 | JACK, DC  |         |              |                                 |
| 46      | A-8025-234-A | (JP)...PWS-13 (JP) ASSY (S)  | 165     | 1-815-422-11 | USB CONNECTOR (VERTICAL)  |         |              |                                 |
| 48      | 1-761-380-23 | CARD, MODEM  | 166     | 1-695-514-21 | JACK (SMALL TYPE) 1P  |         |              |                                 |
| 52      | 1-790-640-11 | FPC 50PIN (FOR CD-ROM)   | 167     | 1-815-221-21 | CONNECTOR, USB (VERTICAL)   |         |              |                                 |
| 53      | 1-790-641-11 | FPC 50PIN (FOR FDD)  | 169     | 4-653-962-01 | SHIELD (USB)  |         |              |                                 |
| 55      | 4-640-845-11 | BUTTON BAY   | 170     | 4-644-667-11 | COVER RJ-11   |         |              |                                 |
| 56      | 4-644-349-01 | LATCH BAY  | 170     | 4-644-667-01 | COVER RJ-11   |         |              |                                 |
| * 57    | 4-640-854-01 | SPRING BAY   | 171     | 4-654-350-11 | SHEET (CPU), THERMAL  |         |              |                                 |
| * 58    | 4-651-850-01 | BRACKET BOTTOM   | 184     | 4-654-776-01 | INSULATOR (SCREW)   |         |              |                                 |
| * 59    | 4-640-857-01 | DOOR BATTERY SPRING  |         |              |   |         |              |                                 |
| 60      | 4-651-698-21 | DISPLAY BASE   |         |              |   |         |              |                                 |
| 63      | 4-651-928-01 | COVER BATTERY CONNECTOR  |         |              |   |         |              |                                 |
| 67      | 4-652-099-21 | (CH)...LABEL I/O   |         |              |   |         |              |                                 |
| 67      | 4-652-099-01 | (JP)...LABEL I/O   |         |              |   |         |              |                                 |
| 68      | 4-641-629-01 | INSULATOR FDD  |         |              |   |         |              |                                 |
| 69      | 4-641-763-21 | LABEL FD   |         |              |   |         |              |                                 |

Confidential

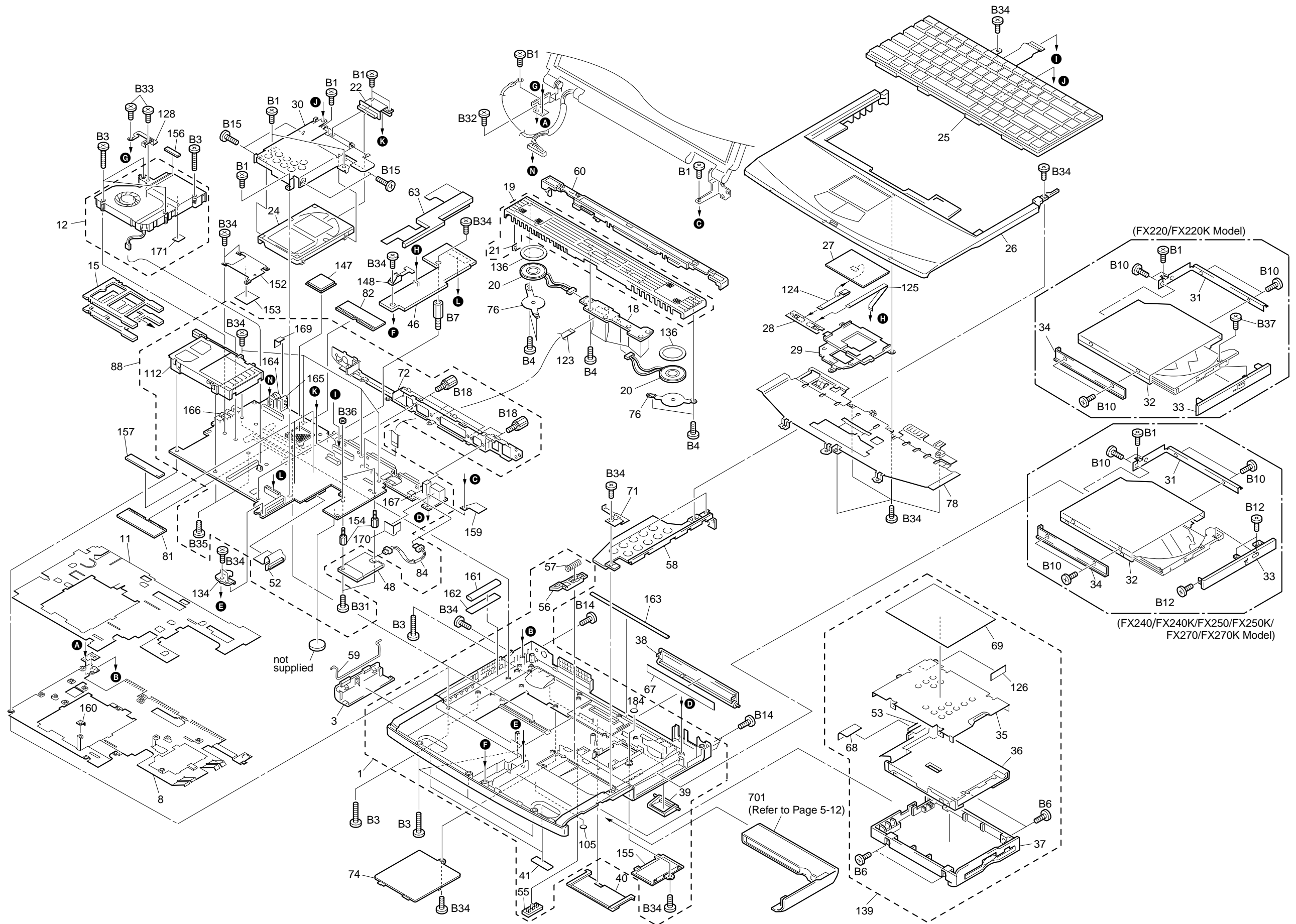

## 5-2. LCD Section (FX270/FX270K Model) – Made by HI –

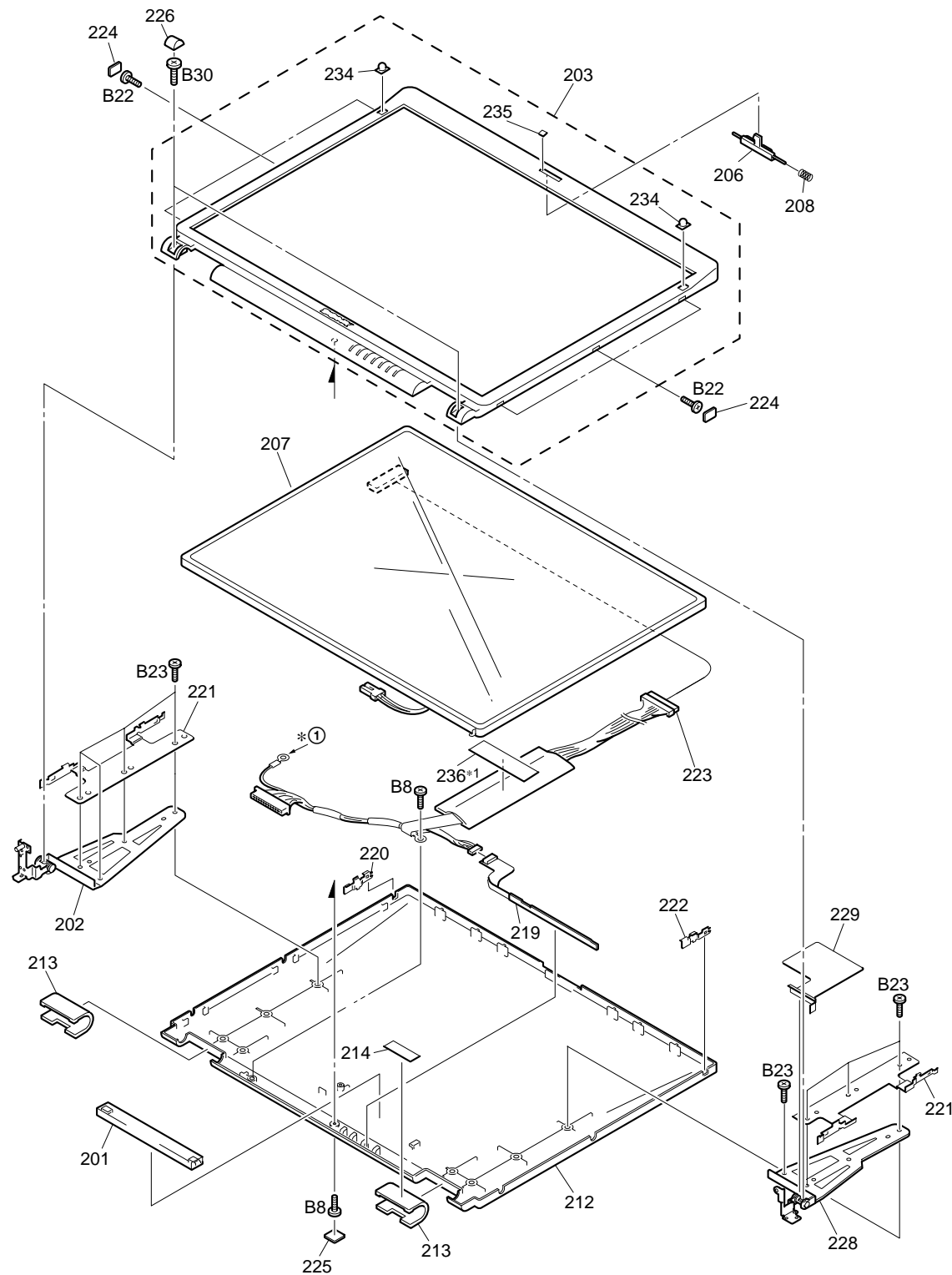

| Ref.No. | Part No.     | Description                  |
|---------|--------------|------------------------------|
| 201     | 1-476-316-11 | INVERTER UNIT                |
| 202     | X-4623-380-1 | HINGE LEFT 15                |
| 203     | X-4623-690-1 | ASSY HOU,BEZEL 15H-Z (EXP)   |
| 206     | 4-637-902-41 | LATCH                        |
| 207     | 1-476-300-11 | ASSY LCD 15SXGA (HI) (S)     |
| 208     | 4-637-903-01 | SPRING LATCH                 |
| 212     | X-4623-689-1 | ASSY HOU,DISPLAY 15H-Z (EXP) |
| 213     | 4-642-762-41 | COVER HINGE (15)             |
| 214     | 4-655-380-11 | (FX270)...LABEL ID (U)       |
| 214     | 4-655-380-51 | (FX270K)...LABEL ID (U)      |
| 219     | 1-757-604-11 | PWB, FLEXIBLE PRINT (SINGLE) |
| * 220   | 4-647-506-01 | BRACKET LCD (L) 15SX         |
| * 221   | 4-647-508-11 | BRACKET LCD (LR) SX          |
| * 222   | 4-647-507-01 | BRACKET LCD (R) 15SX         |
| 223     | 1-961-017-11 | HARNES, LCD (SXGA+)          |
| 224     | 4-646-217-11 | COVER SCREW SIDE (15)        |
| 225     | 4-635-277-22 | COVER SCREW LOWER            |
| 226     | 4-643-549-12 | COVER SCREW SHAFT            |
| 228     | X-4623-381-1 | HINGE RIGHT 15               |
| 229     | 4-643-366-11 | EDGE GUARD HINGE (15)        |
| 234     | 4-635-276-22 | COVER SCREW UPPER            |
| 235     | 4-642-760-12 | CUSHION CENTER               |
| 236     | —————        | FILAMENT TAPE (W12X50)(*1)   |

\*1 : Use the FILAMENT TAPE.

| Ref.No. | Part No.     | Description                     |
|---------|--------------|---------------------------------|
| B8      | 4-641-726-11 | SCREW (M2), SPECIAL HEAD        |
| B22     | 4-641-726-81 | SCREW (M2), SPECIAL HEAD        |
| B23     | 4-644-165-01 | SCREW (M2.6X4), 0 PLATE P1 MAIN |
| B30     | 4-643-550-01 | +P 2.6X6 LOCK PRECISION TYPE3   |

### NOTE :

Set the DIP switch on the MBX-49 board (Main board) to match with the LCD (1-476-300-11) that is used in this computer.



The upper position where ON indication is shown is the ON position . The lower position is the OFF position.

| No.    | 1 | 2 | 3 | 4 | 5 | 6 | 7 | 8 |
|--------|---|---|---|---|---|---|---|---|
| ON/OFF | 0 | 0 | 0 | 0 | 0 | 1 | 1 | 1 |

0 : ON 1 : OFF

\*① For the installation position, refer to page 5-5.

**Confidential**

## 5-3. LCD Section (FX220/FX220K/FX250/FX250K Model) – Made by HI –

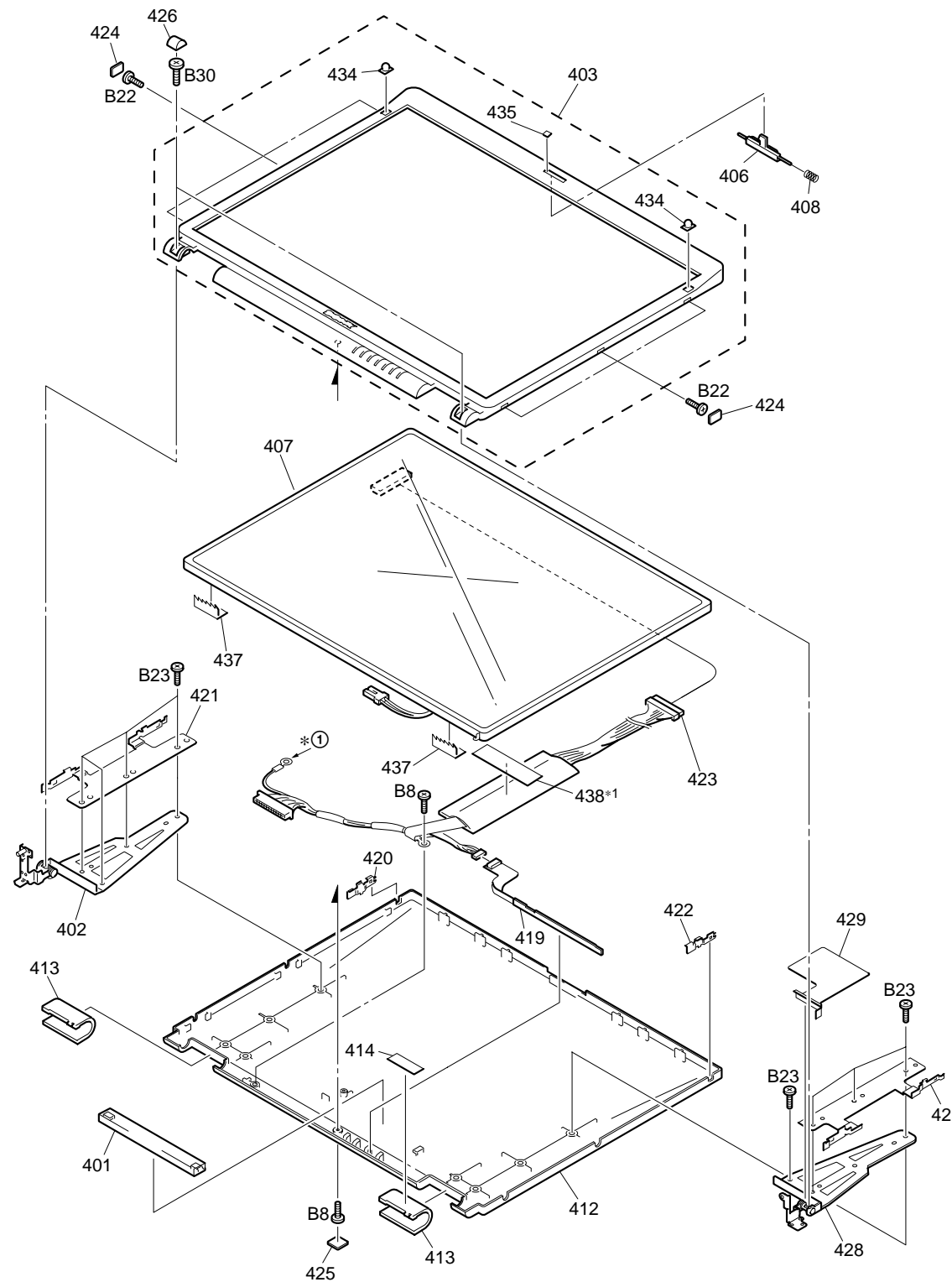

| Ref.No. | Part No.     | Description                   |
|---------|--------------|-------------------------------|
| 401     | 1-476-316-11 | INVERTER UNIT                 |
| 402     | X-4623-380-1 | HINGE LEFT 15                 |
| 403     | X-4623-690-1 | ASSY HOU,BEZEL 15H-Z (EXP)    |
| 406     | 4-637-902-41 | LATCH                         |
| 407     | 1-476-186-12 | ASSY LCD 15HI (S)             |
| 408     | 4-637-903-01 | SPRING LATCH                  |
| 412     | X-4623-689-1 | ASSY HOU, DISPLAY 15H-Z (EXP) |
| 413     | 4-642-762-41 | COVER HINGE (15)              |
| 414     | 4-655-380-41 | (FX220)...LABEL ID (U)        |
| 414     | 4-655-380-81 | (FX220K)...LABEL ID (U)       |
| 414     | 4-655-380-21 | (FX250)...LABEL ID (U)        |
| 414     | 4-655-380-61 | (FX250K)...LABEL ID (U)       |
| 419     | 1-757-604-11 | PWB, FLEXIBLE PRINT (SINGLE)  |
| * 420   | 4-647-506-01 | BRACKET LCD (L) 15SX          |
| * 421   | 4-647-508-11 | BRACKET LCD (LR) SX           |
| * 422   | 4-647-507-01 | BRACKET LCD (R) 15SX          |
| 423     | 1-961-018-11 | HARNESS, LCD (XGA-F-N)        |
| 424     | 4-646-217-11 | COVER SCREW SIDE (15)         |
| 425     | 4-635-277-22 | COVER SCREW LOWER             |
| 426     | 4-643-549-12 | COVER SCREW SHAFT             |
| 428     | X-4623-381-1 | HINGE RIGHT 15                |
| 429     | 4-643-366-11 | EDGE GUARD HINGE (15)         |
| 434     | 4-635-276-22 | COVER SCREW UPPER             |
| 435     | 4-642-760-12 | CUSHION CENTER                |
| 437     | 4-643-837-01 | SHIELD (LCD)                  |
| 438     |              | FILAMENT TAPE (W12X50)(*1)    |

\*1 : Use the FILAMENT TAPE.

| Ref.No. | Part No.     | Description                     |
|---------|--------------|---------------------------------|
| B8      | 4-641-726-11 | SCREW (M2), SPECIAL HEAD        |
| B22     | 4-641-726-81 | SCREW (M2), SPECIAL HEAD        |
| B23     | 4-644-165-01 | SCREW (M2.6X4), 0 PLATE P1 MAIN |
| B30     | 4-643-550-01 | +P 2.6X6 LOCK PRECISION TYPE3   |

### NOTE :

Set the DIP switch on the MBX-49 board (Main board) to match with the LCD (1-476-186-12) that is used in this computer.

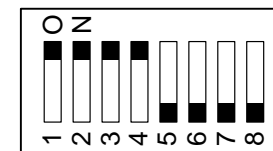

The upper position where ON indication is shown is the ON position . The lower position is the OFF position.

| No.    | 1 | 2 | 3 | 4 | 5 | 6 | 7 | 8 |
|--------|---|---|---|---|---|---|---|---|
| ON/OFF | 0 | 0 | 0 | 0 | 1 | 1 | 1 | 1 |

0 : ON 1 : OFF

\*① For the installation position, refer to page 5-5.

## 5-4. LCD Section (FX240/FX240K Model) – Made by HI –

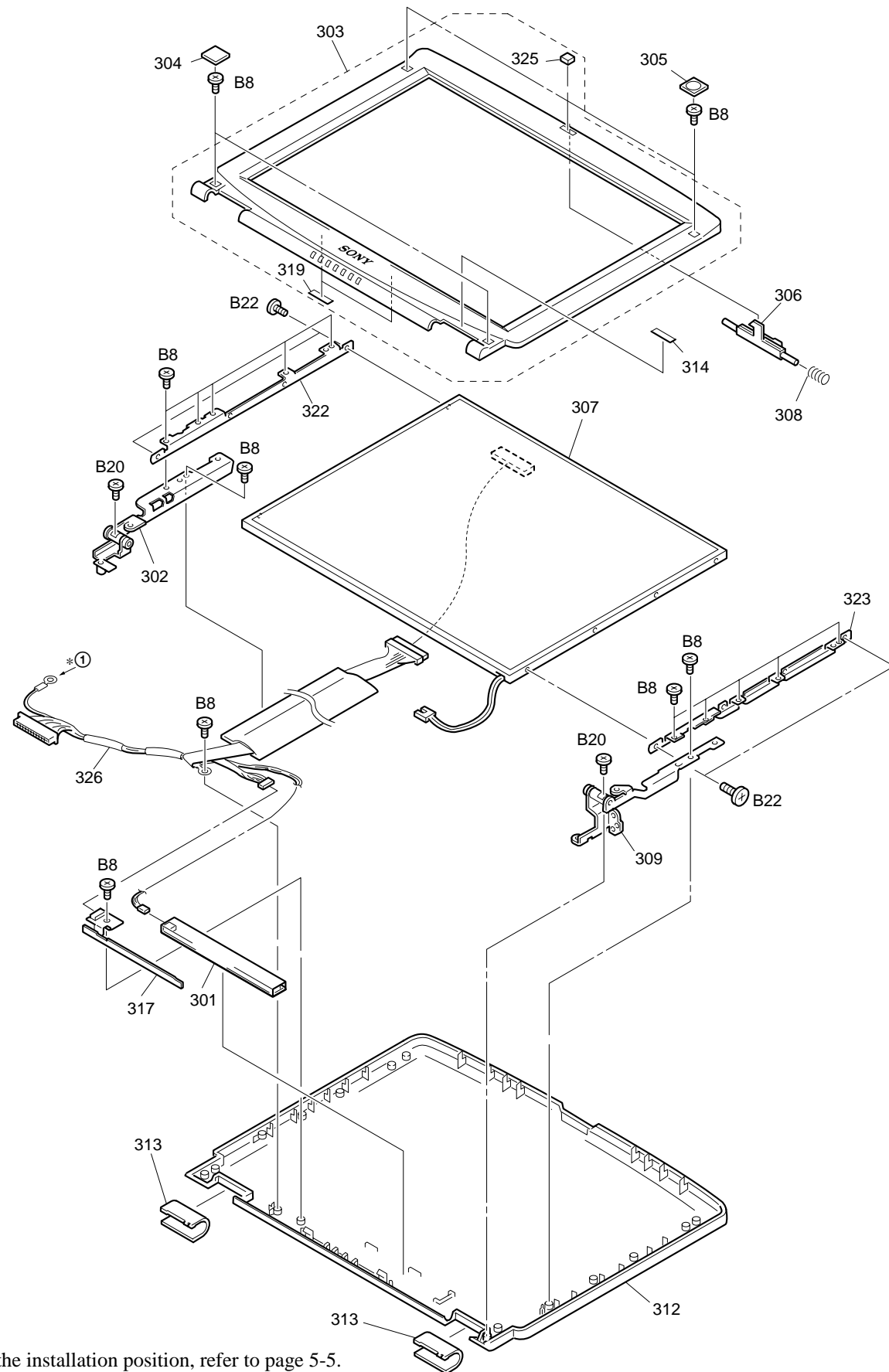

\*① For the installation position, refer to page 5-5.

**Confidential**

| Ref.No. | Part No.     | Description                    |
|---------|--------------|--------------------------------|
| 301     | 1-476-316-11 | INVERTER UNIT                  |
| 302     | X-4623-378-1 | HINGE LEFT MV                  |
| 303     | X-4623-775-1 | ASSY HOU, BEZEL 14H-Z (EXP)    |
| 304     | 4-635-277-22 | COVER SCREW LOWER              |
| 305     | 4-635-276-22 | COVER SCREW UPPER              |
| 306     | 4-637-902-41 | LATCH                          |
| 307     | 1-476-789-11 | LCD UNIT (14XGA HITACHI)       |
| 308     | 4-637-903-01 | SPRING LATCH                   |
| 309     | X-4623-379-1 | HINGE RIGHT MV                 |
| 312     | X-4623-693-1 | ASSY HOU, DISPLAY 14SA-Z (EXP) |
| 313     | 4-642-762-41 | COVER HINGE (15)               |
| 314     | 4-655-380-31 | (FX240)...LABEL ID (U)         |
| 314     | 4-655-380-71 | (FX240K)...LABEL ID (U)        |
| 317     | 1-757-605-11 | PWB, FLEXIBLE PRINT (SINGLE)   |
| 319     | 4-654-966-01 | SHEET (BEZEL), ADHESIVE        |
| * 322   | 4-644-163-01 | BRACKET LCD LEFT 14 (SA)       |
| * 323   | 4-644-164-01 | BRACKET LCD RIGHT 14 (SA)      |
| 325     | 4-642-760-12 | CUSHION CENTER                 |
| 326     | 1-961-018-31 | HARNESS, LCD (XGA-F-N)         |
| B8      | 4-641-726-11 | SCREW (M2), SPECIAL HEAD       |
| B20     | 7-628-254-00 | SCREW +PS 2.6X5                |
| B22     | 4-642-761-01 | +P M2X3 LOCK                   |

### NOTE :

Set the DIP switch on the MBX-49 board (Main board) to match with the LCD (1-476-789-11) that is used in this computer.

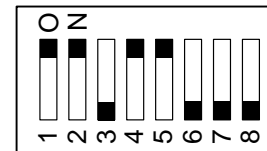

The upper position where ON indication is shown is the ON position . The lower position is the OFF position.

| No.    | 1 | 2 | 3 | 4 | 5 | 6 | 7 | 8 |
|--------|---|---|---|---|---|---|---|---|
| ON/OFF | 0 | 0 | 1 | 0 | 0 | 1 | 1 | 1 |

0 : ON 1 : OFF

| Ref.No.              | Part No.     | Description   |
|----------------------|--------------|---|
| ACCESSORIES<br>***** |              |   |
| 701                  | A-8048-965-A | ASSY WEIGHT SAVER (Z)<br>(Refer to P.5-4)                   |
| △ 702                | 1-476-342-21 | ADAPTOR, AC   |
| 703                  | 1-528-935-21 | (FX250/FX250K/FX270/FX270K)...<br>BATTERY PACK, LITHIUM ION |
| 703                  | 1-756-147-11 | (FX220/FX220K/FX240/FX240K)...<br>BATTERY PACK, LITHIUM ION |
| 704                  | 1-575-875-51 | CORD, CONNECTION  |
| △                    | 1-757-562-21 | CORD,POWER  |
|                      | 4-655-567-11 | QUICK START FX200SERIES                                     |

**701**  
Weight saver (1)

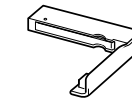

**703**  
Battery pack (1)

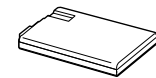

**702**  
AC adaptor (1)

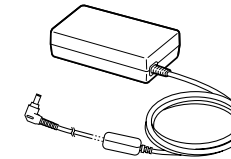

**704**  
Video cable (1)

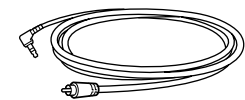

The components identified by mark △ or dotted line with mark △ are critical for safety. Replace only with part number specified.

Les composants identifiés par une marque △ sont critiques pour la sécurité. Ne les remplacer que par une pièce portant le numéro spécifié.

## 5-5. Connector Section

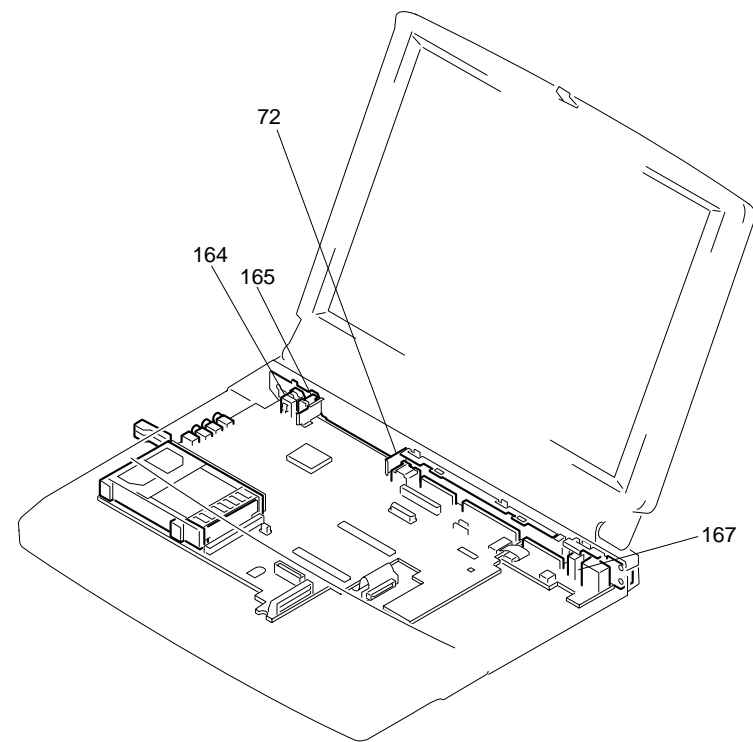

\*Before replacing the connector of reference number 164, 165 and 167, remove the I/O bracket. For the disassembling procedure, refer to page 1-17.

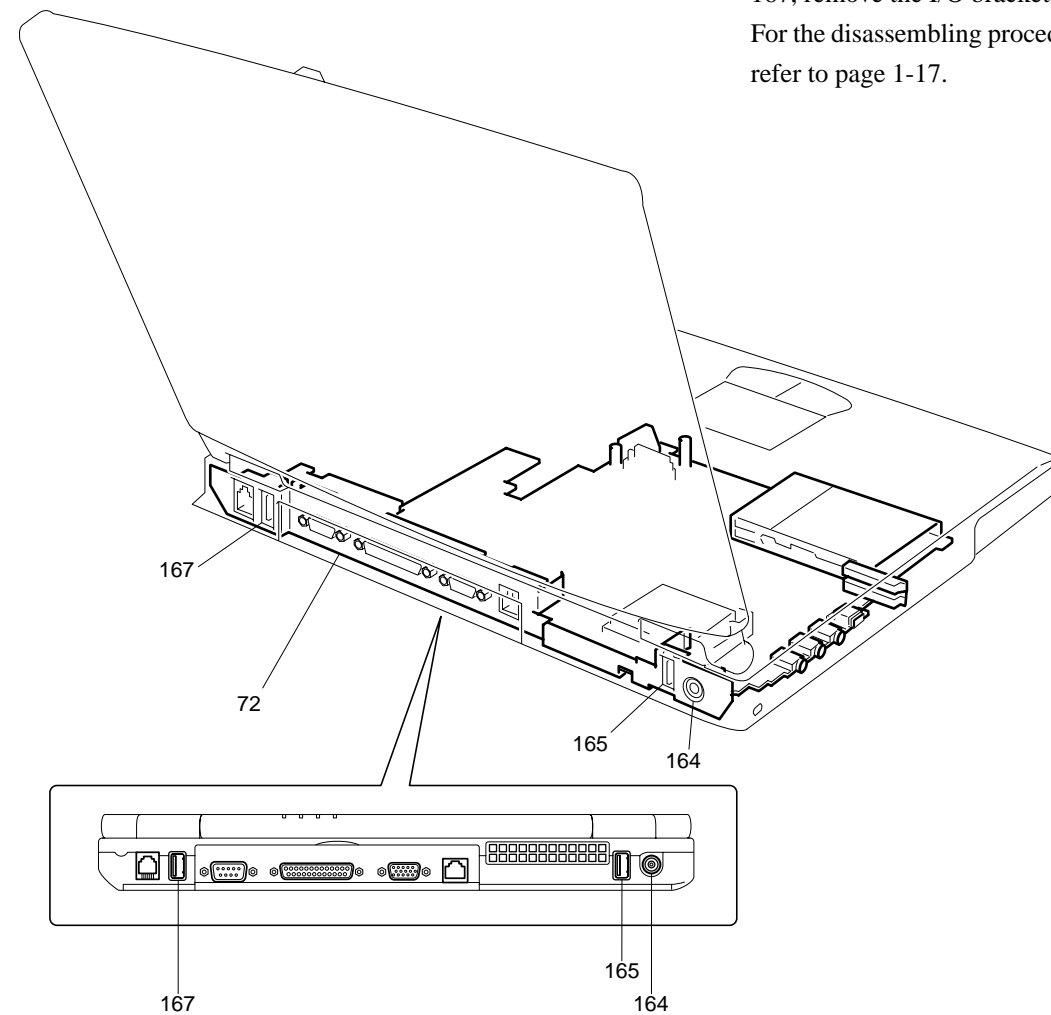

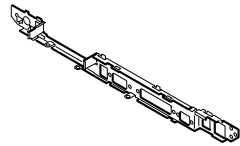
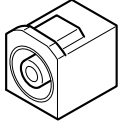
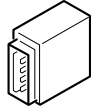
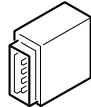
| Ref.No. | Fig.  | Part No.   | Description                                |
|---------|---|--|--|
| 72      |  | 4-651-709-41 (CH)...BRACKET IO<br>4-651-709-01 (JP)...BRACKET IO | I/O BRACKET                                |
| 164     |  | 1-779-745-21   | JACK, DC<br>DC IN connector                |
| 165     |  | 1-815-422-11   | CONNECTOR (VERTICAL)<br>USB connector      |
| 167     |  | 1-815-221-21   | CONNECTOR, USB (VERTICAL)<br>USB connector |

**List of PCG-FX Series (As of May, 2001)**

| <b>Model Name</b>  | <b>Service Manual Part No.</b> |
|--|--------------------------------|
| PCG-FX290K<br>PCG-FX290  | 9-872-209-11                   |
| PCG-FX190K<br>PCG-FX170K<br>PCG-FX150K<br>PCG-FX140K<br>PCG-FX120K                                       | 9-872-194-11                   |
| PCG-FX190<br>PCG-FX170<br>PCG-FX150<br>PCG-FX140<br>PCG-FX120  | 9-872-179-11                   |
| PCG-FX270K<br>PCG-FX270<br>PCG-FX250K<br>PCG-FX250<br>PCG-FX240K<br>PCG-FX240<br>PCG-FX220K<br>PCG-FX220 | 9-872-227-11                   |
| PCG-FX210  | 9-872-204-11                   |
| PCG-FX215  | 9-872-232-11                   |

 : Additional Models

This manual and the constituent data may not be replicated, copied nor reprinted in whole or in part without prior written authorization of Sony Corporation.