



VAIO User Guide

How to Use

Parts Description

Setup

Network / Internet

Connections

Settings

Backup / Recovery

Security

Other Operations

Notifications

SVE1111 Series

Use this manual if you encounter any problems, or have any questions about your VAIO computer.

[Read This First](#)



[▶ Troubleshooting](#)

How to Use

Parts Description

Setup

Network / Internet

Connections

Settings

Backup / Recovery

Security

Other Operations

Notifications

Parts Description

[VAIO computer](#)



[▶ Troubleshooting](#)

How to Use

Parts Description

Setup

Network / Internet

Connections

Settings

Backup / Recovery

Security

Other Operations

Notifications

Setup

[Battery](#)

[Power](#)

[VAIO computer](#)

[Memory module](#)

[Supplied items](#)



[▶ Troubleshooting](#)

How to Use

Parts Description

Setup

Network / Internet

Connections

Settings

Backup / Recovery

Security

Other Operations

Notifications

Network / Internet

[Internet](#)

[LAN](#)

[Wireless LAN](#)



[▶ Troubleshooting](#)

How to Use

Parts Description

Setup

Network / Internet

Connections

Settings

Backup / Recovery

Security

Other Operations

Notifications

Connections

[Audio](#)

[Battery](#)

[Display](#)

[Headphones](#)

[LAN](#)

[Optical digital output](#)

[Power](#)

[USB](#)

[BLUETOOTH](#)

[CD/DVD/BD](#)

[HDMI](#)

[Internet](#)

[Microphone](#)

[Peripheral device](#)

[Speakers](#)

[Wireless LAN](#)



[▶ Troubleshooting](#)

How to Use

Parts Description

Setup

Network / Internet

Connections

Settings

Backup / Recovery

Security

Other Operations

Notifications

Settings

[Audio](#)

[Battery](#)

[CD/DVD/BD](#)

[Display](#)

[Keyboard](#)

[Microphone](#)

[Password](#)

[Power](#)

[Service and support](#)

[Touch pad](#)

[BIOS](#)

[Button](#)

[Camera](#)

[HDMI](#)

[Memory module](#)

[Optical digital output](#)

[Peripheral device](#)

[Security](#)

[Speakers](#)

[VAIO computer](#)



[▶ Troubleshooting](#)

How to Use

Parts Description

Setup

Network / Internet

Connections

Settings

Backup / Recovery

Security

Other Operations

Notifications

Backup / Recovery

[BIOS](#)

[Built-in storage device](#)

[CD/DVD/BD](#)

[Recovery](#)

[VAIO computer](#)

[Backup](#)

[Button](#)

[Partition](#)

[Service and support](#)



[▶ Troubleshooting](#)

How to Use

Parts Description

Setup

Network / Internet

Connections

Settings

Backup / Recovery

Security

Other Operations

Notifications

Security

[BIOS](#)

[Password](#)

[VAIO computer](#)

[Internet](#)

[Service and support](#)



[▶ Troubleshooting](#)

How to Use

[Parts Description](#)

[Setup](#)

[Network / Internet](#)

[Connections](#)

[Settings](#)

[Backup / Recovery](#)

[Security](#)

[Other Operations](#)

[Notifications](#)

Other Operations

[Battery](#)

[Camera](#)

[Memory card](#)

[Partition](#)

[Touch pad](#)

[VAIO computer](#)

[Built-in storage device](#)

[Keyboard](#)

[Memory module](#)

[Power](#)

[USB](#)



[▶ Troubleshooting](#)

How to Use

Parts Description

Setup

Network / Internet

Connections

Settings

Backup / Recovery

Security

Other Operations

Notifications

Notifications

[Care and maintenance](#)

[Product registration](#)

[Security](#)

[Supplied items](#)

[Important notice](#)

[Read this first](#)

[Service and support](#)

[VAIO computer](#)



[▶ How to Use](#)

Troubleshooting

Hardware

Software

Network / Internet

Backup / Recovery

Security

Peripheral Devices

VAIO User Guide

SVE1111 Series

Use this manual if you encounter any problems, or have any questions about your VAIO computer.

[▶ Troubleshooting](#)

How to Use

[Parts Description](#)

[Setup](#)

[Network / Internet](#)

[Connections](#)

[Settings](#)

[Backup / Recovery](#)

[Security](#)

[Other Operations](#)

[Notifications](#)

Read This First

Congratulations on your purchase of this VAIO(R) computer and welcome to the on-screen User Guide.

About your VAIO computer's configuration

To find out about the configuration of your VAIO computer, visit the Sony online support website. [\[Details\]](#)

Some features, options, and supplied items may not be available on your VAIO computer.

Features

Available features vary depending on the model or options you selected. Not all features described in this manual are available depending on your model.

Illustrations

Illustrations, photos, or screenshots in this manual may look slightly different depending on the model or options you selected.

Software

The preinstalled software may vary depending on the model or options you selected. The software described in this manual may not be preinstalled on your VAIO computer.

Supplied manuals

The following manuals are supplied with your VAIO computer.

On-screen documentation

- User Guide - Introduction version [\[Details\]](#)
A preinstalled manual with limited information of your VAIO computer, focused on support and Internet connection. The User Guide - Introduction version is replaced with a complete version of the User Guide (this manual), after update.
- User Guide (this manual)
General information and operation instructions about your VAIO computer including support and troubleshooting information

Printed documentation

- Quick Start Guide
An overview of how to set up and get started with your VAIO computer
- Recovery, Backup and Troubleshooting Guide
Information on how to recover and back up your VAIO computer, as well as troubleshooting information
- Safety Regulations
Read carefully before activating the wireless functions such as the wireless LAN and BLUETOOTH technology.

Other references

- Help and Support
General information and technical support for your VAIO computer.
To access Help and Support, click  (Start), then Help and Support. Next, choose a category to find answers to your questions.
 - Get started with my VAIO
Get help with Internet and wireless setup, security setup, personalizing your VAIO computer, creating Recovery Media, and more.
 - Use my VAIO
Get assistance with your VAIO computer by accessing useful information such as interactive VAIO tutorials, how-to articles, the VAIO technology page, specifications, and system and software information. Available information may vary depending on your model. Documentation such as the General User Guide and Model Specific User Guide are available on your computer.
 - Troubleshoot my VAIO
Maintain and troubleshoot your VAIO computer with VAIO Care, system restore, backup and recovery, and contact Sony support.
- Software help files
Software help files may be included with the preinstalled software on your VAIO computer. You may be able to access the help files from the help menu.

Notice

- Copyright 2012 Sony Corporation. All rights reserved.
- This manual and the software described herein, in whole or in part, may not be reproduced, translated, or reduced to any machine-readable form without prior written approval.
- Sony Corporation provides no warranty with regard to this manual, the software, or other information contained herein and hereby expressly disclaims any implied warranties or merchantability or fitness for any particular purpose with regard to this manual, the software, or such other information. In no event shall Sony Corporation be liable for any incidental, consequential, or special damages, whether based on tort, contract, or otherwise, arising out of or in connection with this manual, the software, or other information contained herein or the use thereof.
- In the manual, the (TM) or (R) marks are not specified.
- Sony Corporation reserves the right to make any modification to this manual or the information contained herein at any time without notice. The software described herein is governed by the terms of a separate user license agreement.
- Sony Corporation is not liable and will not compensate for any lost recordings made to your VAIO computer, external recording media, or recording devices or any relevant losses, including when recordings are not made due to reasons including the computer failure, or when the contents of a recording are lost or damaged as a result of the computer failure or repair undertaken to the computer. Sony Corporation will not restore, recover, or replicate the recorded contents made to the computer, external recording media, or recording devices under any circumstances.
- Features and specifications are subject to change without notice.

Related Topic

[About Online Support Website](#)

[▶ Troubleshooting](#)**How to Use****Parts Description**

[Setup](#)

[Network / Internet](#)

[Connections](#)

[Settings](#)

[Backup / Recovery](#)

[Security](#)

[Other Operations](#)

[Notifications](#)

VAIO computer[Parts and Controls on the Bottom](#)

Describes the features on the bottom of the VAIO computer.

[Parts and Controls on the Front](#)

Describes the features on the front of the VAIO computer, such as buttons and indicator lights.

[Parts and Controls on the Sides](#)

Describes the features on the sides of the VAIO computer, such as connection ports.

You might be looking for the following topics:

[About the ASSIST Button](#)[Adding and Removing Memory Modules](#)[Booting Your VAIO Computer from External Devices](#)[Checking Supplied Items](#)[Customizing Your VAIO Computer](#)[Keeping Your VAIO Computer in Optimum Condition \(VAIO Care\)](#)[Notes on Adding and Removing Memory Modules](#)[Setting Up an Appropriate Work Environment](#)[Updating Your VAIO Computer](#)[Using VAIO Update](#)[Viewing the System Information](#)

[▶ Troubleshooting](#)

How to Use

[Parts Description](#)[Setup](#)[Network / Internet](#)

[Connections](#)

[Settings](#)

[Backup / Recovery](#)

[Security](#)

[Other Operations](#)

[Notifications](#)

Battery

[Charging the Battery Pack](#)

The battery pack can be charged even while you are using your VAIO computer when the computer is connected to a power source.

[Installing/Removing the Battery Pack](#)

Install the battery pack into the battery compartment on the bottom of your VAIO computer.

You might be looking for the following topics:

[Changing the Rapid Wake \(Sleep Mode\) Settings](#)[Charge Indicator Status List](#)[Checking the Battery Charge Capacity](#)[Extending the Battery Life](#)[Notes on Using the Battery Pack](#)

[▶ Troubleshooting](#)

How to Use

[Parts Description](#)[Setup](#)[Network / Internet](#)

[Connections](#)

[Settings](#)

[Backup / Recovery](#)

[Security](#)

[Other Operations](#)

[Notifications](#)

Power

[Charging the Battery Pack](#)

The battery pack can be charged even while you are using your VAIO computer when the computer is connected to a power source.

[Connecting a Power Source](#)

Connect your VAIO computer to an AC power source. Carefully read the precautions in [Notes on Using the Power Source](#) before connection. [Details]

[Installing/Removing the Battery Pack](#)

Install the battery pack into the battery compartment on the bottom of your VAIO computer.

[Shutting Down Your VAIO Computer](#)

Shut down your VAIO computer properly to avoid losing unsaved data.

[Turning on Your VAIO Computer](#)

Turn on your VAIO computer to start Windows. Carefully read the precautions in [Notes on Using the Power Source](#) before turning on. [Details]

You might be looking for the following topics:

[Changing the Rapid Wake \(Sleep Mode\) Settings](#)[Charge Indicator Status List](#)[Notes on Sleep Mode](#)[Notes on Using the Power Source](#)[Restarting Your VAIO Computer](#)[Selecting a Power Plan](#)[Using Sleep Mode](#)

[▶ Troubleshooting](#)

How to Use

[Parts Description](#)[Setup](#)[Network / Internet](#)

[Connections](#)

[Settings](#)

[Backup / Recovery](#)

[Security](#)

[Other Operations](#)

[Notifications](#)

VAIO computer

[Adding and Removing Memory Modules](#)

If you want to increase your computer's speed or improve performance when running programs simultaneously, increase the amount of memory by installing optional memory modules.

[Checking Supplied Items](#)

Check all items packed with the product before use.

[Notes on Adding and Removing Memory Modules](#)

Before adding or removing memory modules, read the following precautions thoroughly.

[Setting Up an Appropriate Work Environment](#)

This topic describes where to or not to place your VAIO computer and ergonomic instructions.

You might be looking for the following topics:

[About the ASSIST Button](#)[Booting Your VAIO Computer from External Devices](#)[Customizing Your VAIO Computer](#)[Keeping Your VAIO Computer in Optimum Condition \(VAIO Care\)](#)[Parts and Controls on the Bottom](#)[Parts and Controls on the Front](#)[Parts and Controls on the Sides](#)[Updating Your VAIO Computer](#)[Using VAIO Update](#)[Viewing the System Information](#)

[▶ Troubleshooting](#)

How to Use

[Parts Description](#)[Setup](#)[Network / Internet](#)

[Connections](#)

[Settings](#)

[Backup / Recovery](#)

[Security](#)

[Other Operations](#)

[Notifications](#)

Memory module

[Adding and Removing Memory Modules](#)

If you want to increase your computer's speed or improve performance when running programs simultaneously, increase the amount of memory by installing optional memory modules.

[Notes on Adding and Removing Memory Modules](#)

Before adding or removing memory modules, read the following precautions thoroughly.

You might be looking for the following topics:

[Viewing the System Information](#)



[▶ Troubleshooting](#)

How to Use

Parts Description

Setup

Network / Internet

Connections

Settings

Backup / Recovery

Security

Other Operations

Notifications

Supplied items

[Checking Supplied Items](#)

Check all items packed with the product before use.

[▶ Troubleshooting](#)**How to Use**[Parts Description](#)[Setup](#)[Network / Internet](#)[Connections](#)[Settings](#)[Backup / Recovery](#)[Security](#)[Other Operations](#)[Notifications](#)

Internet

[About a Security Key for a Wireless LAN](#)

A security key is a security protocol for a wireless LAN that encrypts data transmitted on the wireless LAN.

[About the Internet Connection Services](#)

The following types of Internet connection services are available.

[About the Network \(LAN\)](#)

The network (LAN) enables you to connect your VAIO computer to the Internet and transfer data between the computer and other devices.

[About the Wireless LAN Standards](#)

The Wireless Local Area Network (WLAN) allows your VAIO computer to connect to a network through a wireless connection.

[Before Using the Wireless LAN](#)

You first need to establish wireless LAN communications between your VAIO computer and an access point (not supplied) before connecting the computer to the Internet using the wireless LAN. Refer to Windows Help and Support and the manual that came with your access point for more information.

[Connecting to the Internet with a Wired Connection](#)

Before using the Internet, you need to sign up with an Internet Service Provider (ISP) and set up devices required for connecting your VAIO computer to the Internet.

[Launching the Web Browser \(WEB Button\)](#)

By pressing the WEB button, you can launch the default web browser.

[Notes on Using the Wireless LAN Function](#)

Before using the wireless LAN function, read the following precautions for correct use.

[Starting Wireless LAN Communications](#)

You can establish wireless LAN communications between your VAIO computer and an access point (not supplied) using VAIO Smart Network. Before using the wireless LAN, make sure your access point is on and operating.

[Stopping Wireless LAN Communications](#)

Stop wireless LAN communications using VAIO Smart Network.

[Using the Antivirus Software for Your VAIO Computer](#)

Protect your VAIO computer against computer viruses by using the antivirus software.

[▶ Troubleshooting](#)

How to Use

[Parts Description](#)

[Setup](#)

[Network / Internet](#)

[Connections](#)

[Settings](#)

[Backup / Recovery](#)

[Security](#)

[Other Operations](#)

[Notifications](#)

Wireless LAN

[About a Security Key for a Wireless LAN](#)

A security key is a security protocol for a wireless LAN that encrypts data transmitted on the wireless LAN.

[About the Internet Connection Services](#)

The following types of Internet connection services are available.

[About the Wireless LAN Standards](#)

The Wireless Local Area Network (WLAN) allows your VAIO computer to connect to a network through a wireless connection.

[Before Using the Wireless LAN](#)

You first need to establish wireless LAN communications between your VAIO computer and an access point (not supplied) before connecting the computer to the Internet using the wireless LAN. Refer to Windows Help and Support and the manual that came with your access point for more information.

[Notes on Using the Wireless LAN Function](#)

Before using the wireless LAN function, read the following precautions for correct use.

[Starting Wireless LAN Communications](#)

You can establish wireless LAN communications between your VAIO computer and an access point (not supplied) using VAIO Smart Network. Before using the wireless LAN, make sure your access point is on and operating.

[Stopping Wireless LAN Communications](#)

Stop wireless LAN communications using VAIO Smart Network.

[▶ Troubleshooting](#)

How to Use

[Parts Description](#)

[Setup](#)

[Network / Internet](#)

[Connections](#)

[Settings](#)

[Backup / Recovery](#)

[Security](#)

[Other Operations](#)

[Notifications](#)

LAN

[About the Internet Connection Services](#)

The following types of Internet connection services are available.

[About the Network \(LAN\)](#)

The network (LAN) enables you to connect your VAIO computer to the Internet and transfer data between the computer and other devices.

[About the Wireless LAN Standards](#)

The Wireless Local Area Network (WLAN) allows your VAIO computer to connect to a network through a wireless connection.

[Connecting to the Internet with a Wired Connection](#)

Before using the Internet, you need to sign up with an Internet Service Provider (ISP) and set up devices required for connecting your VAIO computer to the Internet.

[▶ Troubleshooting](#)

How to Use

[Parts Description](#)

[Setup](#)

[Network / Internet](#)

[Connections](#)

[Settings](#)

[Backup / Recovery](#)

[Security](#)

[Other Operations](#)

[Notifications](#)

Audio

[Changing the Sound Output Device](#)

If there is no sound from the device connected to your VAIO computer, you need to change the device for sound output.

[Connecting External Speakers or Headphones](#)

You can connect external sound output devices (such as speakers or headphones) to your VAIO computer.

[Connecting a High-Quality Digital Sound Output Device between Your VAIO Computer and a TV](#)

You can connect a high-quality home theater receiver or other surround sound decoder devices between your VAIO computer and a TV using an HDMI connection.

[Connecting an External Microphone](#)

You can connect an external microphone to your VAIO computer and enjoy voice chat, etc.

You might be looking for the following topics:

[Adjusting the Microphone Volume](#)[Adjusting the Speakers Volume](#)[Adjusting the Volume in Windows](#)

[▶ Troubleshooting](#)

How to Use

[Parts Description](#)

[Setup](#)

[Network / Internet](#)

[Connections](#)

[Settings](#)

[Backup / Recovery](#)

[Security](#)

[Other Operations](#)

[Notifications](#)

Battery

[Installing/Removing the Battery Pack](#)

Install the battery pack into the battery compartment on the bottom of your VAIO computer.

You might be looking for the following topics:

[Changing the Rapid Wake \(Sleep Mode\) Settings](#)[Charge Indicator Status List](#)[Charging the Battery Pack](#)[Checking the Battery Charge Capacity](#)[Extending the Battery Life](#)[Notes on Using the Battery Pack](#)

[▶ Troubleshooting](#)**How to Use**[Parts Description](#)[Setup](#)[Network / Internet](#)[Connections](#)[Settings](#)[Backup / Recovery](#)[Security](#)[Other Operations](#)[Notifications](#)

Display

[Changing the Resolution \(Size\) of the Screen Image on an HDMI-Connected Device](#)

You can change the screen resolution or size of your VAIO computer's screen image displayed on an external display, such as a TV, connected to the computer with an HDMI cable (not supplied).

[Connecting a TV with an HDMI Input Port](#)

You can connect a TV with an HDMI input port to your VAIO computer with an HDMI cable (not supplied).

[Connecting an External Display or Projector](#)

You can connect an external display (such as a computer display or a projector) to your VAIO computer with a display cable (not supplied).

[Notes on the LCD screen](#)

Read the following precautions for correct use of the LCD screen.

[Selecting Display Modes](#)

You can switch the display output between the computer screen and an external display connected to your VAIO computer.

[Using the Multiple Monitors Function](#)

The Multiple Monitors function allows you to distribute portions of your desktop across separate displays.

You might be looking for the following topics:

[Changing the LCD Brightness](#)

[Changing the Resolution \(Size\) of the Screen Image](#)

[▶ Troubleshooting](#)

How to Use

[Parts Description](#)

[Setup](#)

[Network / Internet](#)

[Connections](#)

[Settings](#)

[Backup / Recovery](#)

[Security](#)

[Other Operations](#)

[Notifications](#)

Headphones

[Connecting External Speakers or Headphones](#)

You can connect external sound output devices (such as speakers or headphones) to your VAIO computer.

[▶ Troubleshooting](#)

How to Use

[Parts Description](#)

[Setup](#)

[Network / Internet](#)

[Connections](#)

[Settings](#)

[Backup / Recovery](#)

[Security](#)

[Other Operations](#)

[Notifications](#)

LAN

[About the Internet Connection Services](#)

The following types of Internet connection services are available.

[About the Network \(LAN\)](#)

The network (LAN) enables you to connect your VAIO computer to the Internet and transfer data between the computer and other devices.

[About the Wireless LAN Standards](#)

The Wireless Local Area Network (WLAN) allows your VAIO computer to connect to a network through a wireless connection.

[Connecting to the Internet with a Wired Connection](#)

Before using the Internet, you need to sign up with an Internet Service Provider (ISP) and set up devices required for connecting your VAIO computer to the Internet.

[▶ Troubleshooting](#)

How to Use

[Parts Description](#)

[Setup](#)

[Network / Internet](#)

[Connections](#)

[Settings](#)

[Backup / Recovery](#)

[Security](#)

[Other Operations](#)

[Notifications](#)

Optical digital output

[Connecting a High-Quality Digital Sound Output Device between Your VAIO Computer and a TV](#)

You can connect a high-quality home theater receiver or other surround sound decoder devices between your VAIO computer and a TV using an HDMI connection.

[▶ Troubleshooting](#)

How to Use

[Parts Description](#)

[Setup](#)

[Network / Internet](#)

[Connections](#)

[Settings](#)

[Backup / Recovery](#)

[Security](#)

[Other Operations](#)

[Notifications](#)

Power

[Connecting a Power Source](#)

Connect your VAIO computer to an AC power source. Carefully read the precautions in [Notes on Using the Power Source](#) before connection. [\[Details\]](#)

[Installing/Removing the Battery Pack](#)

Install the battery pack into the battery compartment on the bottom of your VAIO computer.

You might be looking for the following topics:

[Changing the Rapid Wake \(Sleep Mode\) Settings](#)[Charge Indicator Status List](#)[Charging the Battery Pack](#)[Notes on Sleep Mode](#)[Notes on Using the Power Source](#)[Restarting Your VAIO Computer](#)[Selecting a Power Plan](#)[Shutting Down Your VAIO Computer](#)[Turning on Your VAIO Computer](#)[Using Sleep Mode](#)

[▶ Troubleshooting](#)

How to Use

[Parts Description](#)

[Setup](#)

[Network / Internet](#)

[Connections](#)

[Settings](#)

[Backup / Recovery](#)

[Security](#)

[Other Operations](#)

[Notifications](#)

USB

Charging a USB Device

You can charge a USB device even while your VAIO computer is off, in Hibernate mode, or Sleep mode by enabling the USB charging settings.

Connecting a USB Device

You can connect a Universal Serial Bus (USB) device such as a mouse, floppy disk drive, speaker or printer to your VAIO computer. Installation of the device driver software supplied with the USB device may be required when connecting. Refer to the manual that came with the device for more information.

[> Troubleshooting](#)

How to Use

[Parts Description](#)

[Setup](#)

[Network / Internet](#)

[Connections](#)

[Settings](#)

[Backup / Recovery](#)

[Security](#)

[Other Operations](#)

[Notifications](#)

BLUETOOTH

[About BLUETOOTH\(R\) Security<BLUETOOTH equipped models>](#)

The BLUETOOTH wireless technology has an authentication function, which allows you to control communication with other devices.

[About the BLUETOOTH\(R\) Function<BLUETOOTH equipped models>](#)

You can establish wireless communications between your VAIO computer and other BLUETOOTH devices, such as another computer, a smartphone, a mobile phone, a headset, or a mouse.

[Communicating with Another BLUETOOTH\(R\) Device such as a Mouse<BLUETOOTH equipped models>](#)

You can connect BLUETOOTH devices to your VAIO computer. For details on BLUETOOTH communication, see [About the BLUETOOTH Function <BLUETOOTH equipped models>](#).
[Details]

[Notes on Using the BLUETOOTH\(R\) Function<BLUETOOTH equipped models>](#)

Before using the BLUETOOTH function, read the following precautions for correct use.

[Stopping BLUETOOTH\(R\) Communications<BLUETOOTH equipped models>](#)

Stop BLUETOOTH communications using VAIO Smart Network.

[▶ Troubleshooting](#)

How to Use

[Parts Description](#)

[Setup](#)

[Network / Internet](#)

[Connections](#)

[Settings](#)

[Backup / Recovery](#)

[Security](#)

[Other Operations](#)

[Notifications](#)

CD/DVD/BD

[Connecting an External DVD Drive](#)

Connect an external DVD drive or hard disk drive to a USB port on your VAIO computer.

You might be looking for the following topics:

[Booting Your VAIO Computer from External Devices](#)

[▶ Troubleshooting](#)

How to Use

[Parts Description](#)

[Setup](#)

[Network / Internet](#)

[Connections](#)

[Settings](#)

[Backup / Recovery](#)

[Security](#)

[Other Operations](#)

[Notifications](#)

HDMI

[Changing the Resolution \(Size\) of the Screen Image on an HDMI-Connected Device](#)

You can change the screen resolution or size of your VAIO computer's screen image displayed on an external display, such as a TV, connected to the computer with an HDMI cable (not supplied).

[Connecting a TV with an HDMI Input Port](#)

You can connect a TV with an HDMI input port to your VAIO computer with an HDMI cable (not supplied).

[▶ Troubleshooting](#)

How to Use

[Parts Description](#)

[Setup](#)

[Network / Internet](#)

[Connections](#)

[Settings](#)

[Backup / Recovery](#)

[Security](#)

[Other Operations](#)

[Notifications](#)

Internet

[About a Security Key for a Wireless LAN](#)

A security key is a security protocol for a wireless LAN that encrypts data transmitted on the wireless LAN.

[About the Internet Connection Services](#)

The following types of Internet connection services are available.

[About the Network \(LAN\)](#)

The network (LAN) enables you to connect your VAIO computer to the Internet and transfer data between the computer and other devices.

[About the Wireless LAN Standards](#)

The Wireless Local Area Network (WLAN) allows your VAIO computer to connect to a network through a wireless connection.

[Before Using the Wireless LAN](#)

You first need to establish wireless LAN communications between your VAIO computer and an access point (not supplied) before connecting the computer to the Internet using the wireless LAN. Refer to Windows Help and Support and the manual that came with your access point for more information.

[Connecting to the Internet with a Wired Connection](#)

Before using the Internet, you need to sign up with an Internet Service Provider (ISP) and set up devices required for connecting your VAIO computer to the Internet.

[Launching the Web Browser \(WEB Button\)](#)

By pressing the WEB button, you can launch the default web browser.

[Notes on Using the Wireless LAN Function](#)

Before using the wireless LAN function, read the following precautions for correct use.

[Starting Wireless LAN Communications](#)

You can establish wireless LAN communications between your VAIO computer and an access point (not supplied) using VAIO Smart Network. Before using the wireless LAN, make sure your access point is on and operating.

[Stopping Wireless LAN Communications](#)

Stop wireless LAN communications using VAIO Smart Network.

[Using the Antivirus Software for Your VAIO Computer](#)

Protect your VAIO computer against computer viruses by using the antivirus software.

[▶ Troubleshooting](#)

How to Use

[Parts Description](#)

[Setup](#)

[Network / Internet](#)

[Connections](#)

[Settings](#)

[Backup / Recovery](#)

[Security](#)

[Other Operations](#)

[Notifications](#)

Microphone

[Connecting an External Microphone](#)

You can connect an external microphone to your VAIO computer and enjoy voice chat, etc.

You might be looking for the following topics:

[Adjusting the Microphone Volume](#)

[▶ Troubleshooting](#)

How to Use

[Parts Description](#)

[Setup](#)

[Network / Internet](#)

[Connections](#)

[Settings](#)

[Backup / Recovery](#)

[Security](#)

[Other Operations](#)

[Notifications](#)

Peripheral device

[Changing the Sound Output Device](#)

If there is no sound from the device connected to your VAIO computer, you need to change the device for sound output.

[Connecting a High-Quality Digital Sound Output Device between Your VAIO Computer and a TV](#)

You can connect a high-quality home theater receiver or other surround sound decoder devices between your VAIO computer and a TV using an HDMI connection.

[Connecting a TV with an HDMI Input Port](#)

You can connect a TV with an HDMI input port to your VAIO computer with an HDMI cable (not supplied).

[Connecting an External Display or Projector](#)

You can connect an external display (such as a computer display or a projector) to your VAIO computer with a display cable (not supplied).

[Connecting an External Microphone](#)

You can connect an external microphone to your VAIO computer and enjoy voice chat, etc.

[Notes on the LCD screen](#)

Read the following precautions for correct use of the LCD screen.

[Selecting Display Modes](#)

You can switch the display output between the computer screen and an external display connected to your VAIO computer.

[Using the Multiple Monitors Function](#)

The Multiple Monitors function allows you to distribute portions of your desktop across separate displays.

[▶ Troubleshooting](#)

How to Use

[Parts Description](#)

[Setup](#)

[Network / Internet](#)

[Connections](#)

[Settings](#)

[Backup / Recovery](#)

[Security](#)

[Other Operations](#)

[Notifications](#)

Speakers

[Connecting External Speakers or Headphones](#)

You can connect external sound output devices (such as speakers or headphones) to your VAIO computer.

You might be looking for the following topics:

[Adjusting the Speakers Volume](#)

[▶ Troubleshooting](#)

How to Use

[Parts Description](#)

[Setup](#)

[Network / Internet](#)

[Connections](#)

[Settings](#)

[Backup / Recovery](#)

[Security](#)

[Other Operations](#)

[Notifications](#)

Wireless LAN

[About a Security Key for a Wireless LAN](#)

A security key is a security protocol for a wireless LAN that encrypts data transmitted on the wireless LAN.

[About the Internet Connection Services](#)

The following types of Internet connection services are available.

[About the Wireless LAN Standards](#)

The Wireless Local Area Network (WLAN) allows your VAIO computer to connect to a network through a wireless connection.

[Before Using the Wireless LAN](#)

You first need to establish wireless LAN communications between your VAIO computer and an access point (not supplied) before connecting the computer to the Internet using the wireless LAN. Refer to Windows Help and Support and the manual that came with your access point for more information.

[Notes on Using the Wireless LAN Function](#)

Before using the wireless LAN function, read the following precautions for correct use.

[Starting Wireless LAN Communications](#)

You can establish wireless LAN communications between your VAIO computer and an access point (not supplied) using VAIO Smart Network. Before using the wireless LAN, make sure your access point is on and operating.

[Stopping Wireless LAN Communications](#)

Stop wireless LAN communications using VAIO Smart Network.

[▶ Troubleshooting](#)

How to Use

[Parts Description](#)

[Setup](#)

[Network / Internet](#)

[Connections](#)

[Settings](#)

[Backup / Recovery](#)

[Security](#)

[Other Operations](#)

[Notifications](#)

Audio

[Adjusting the Microphone Volume](#)

You can adjust the volume level of the microphone.

[Adjusting the Speakers Volume](#)

You can change the volume level of the speakers and headphones.

[Adjusting the Volume in Windows](#)

You can adjust the volume on each software application from the Control Panel window.

[Changing the Sound Output Device](#)

If there is no sound from the device connected to your VAIO computer, you need to change the device for sound output.

[Connecting a High-Quality Digital Sound Output Device between Your VAIO Computer and a TV](#)

You can connect a high-quality home theater receiver or other surround sound decoder devices between your VAIO computer and a TV using an HDMI connection.

You might be looking for the following topics:

[Connecting External Speakers or Headphones](#)

[Connecting an External Microphone](#)

[▶ Troubleshooting](#)

How to Use

[Parts Description](#)

[Setup](#)

[Network / Internet](#)

[Connections](#)

[Settings](#)

[Backup / Recovery](#)

[Security](#)

[Other Operations](#)

[Notifications](#)

Battery

[Notes on Using the Battery Pack](#)

Before using the battery pack, read the following precautions for correct use.

You might be looking for the following topics:

[Changing the Rapid Wake \(Sleep Mode\) Settings](#)[Charge Indicator Status List](#)[Charging the Battery Pack](#)[Checking the Battery Charge Capacity](#)[Extending the Battery Life](#)[Installing/Removing the Battery Pack](#)

[▶ Troubleshooting](#)

How to Use

[Parts Description](#)

[Setup](#)

[Network / Internet](#)

[Connections](#)[Settings](#)[Backup / Recovery](#)

[Security](#)

[Other Operations](#)

[Notifications](#)

CD/DVD/BD

[Booting Your VAIO Computer from External Devices](#)

You can boot your VAIO computer from external devices, such as an optical disc drive or a USB floppy disk drive, by using the BIOS function.

You might be looking for the following topics:

[Connecting an External DVD Drive](#)

[▶ Troubleshooting](#)**How to Use**[Parts Description](#)[Setup](#)[Network / Internet](#)[Connections](#)[Settings](#)[Backup / Recovery](#)[Security](#)[Other Operations](#)[Notifications](#)

Display

[Changing the LCD Brightness](#)

You can adjust the LCD brightness.

[Changing the Resolution \(Size\) of the Screen Image](#)

You can change the screen resolution to adjust the size of the characters and images on the computer screen.

[Changing the Resolution \(Size\) of the Screen Image on an HDMI-Connected Device](#)

You can change the screen resolution or size of your VAIO computer's screen image displayed on an external display, such as a TV, connected to the computer with an HDMI cable (not supplied).

[Connecting a TV with an HDMI Input Port](#)

You can connect a TV with an HDMI input port to your VAIO computer with an HDMI cable (not supplied).

[Connecting an External Display or Projector](#)

You can connect an external display (such as a computer display or a projector) to your VAIO computer with a display cable (not supplied).

[Notes on the LCD screen](#)

Read the following precautions for correct use of the LCD screen.

[Selecting Display Modes](#)

You can switch the display output between the computer screen and an external display connected to your VAIO computer.

[Using the Multiple Monitors Function](#)

The Multiple Monitors function allows you to distribute portions of your desktop across separate displays.

[▶ Troubleshooting](#)

How to Use

[Parts Description](#)

[Setup](#)

[Network / Internet](#)

[Connections](#)

[Settings](#)

[Backup / Recovery](#)

[Security](#)

[Other Operations](#)

[Notifications](#)

Keyboard

[Changing the Button Assignment \(VAIO Button\)](#)

You can change the current task assigned to the VAIO button. [\[Details\]](#)

You might be looking for the following topics:

[Combinations and Functions with the Fn Key](#)

[▶ Troubleshooting](#)

How to Use

[Parts Description](#)

[Setup](#)

[Network / Internet](#)

[Connections](#)

[Settings](#)

[Backup / Recovery](#)

[Security](#)

[Other Operations](#)

[Notifications](#)

Microphone

[Adjusting the Microphone Volume](#)

You can adjust the volume level of the microphone.

You might be looking for the following topics:

[Connecting an External Microphone](#)

[▶ Troubleshooting](#)

How to Use

[Parts Description](#)

[Setup](#)

[Network / Internet](#)

[Connections](#)

[Settings](#)

[Backup / Recovery](#)

[Security](#)

[Other Operations](#)

[Notifications](#)

Password

[Creating/Changing/Removing Your Windows Password](#)

Setting the Windows password allows you to protect your VAIO computer from unauthorized access by making the user enter the password when the computer is turned on or returns from power saving mode to Normal mode.

[Removing the Power-on Password](#)

If power-on password input for booting up your VAIO computer is no longer necessary, follow these steps to remove the machine password and user password.

[Setting/Changing the Power-on Password](#)

You can set a password (power-on password) for booting up your VAIO computer, using the BIOS function. Entry of the power-on password will be prompted after the VAIO logo appears to start the computer.

[▶ Troubleshooting](#)

How to Use

[Parts Description](#)

[Setup](#)

[Network / Internet](#)

[Connections](#)

[Settings](#)

[Backup / Recovery](#)

[Security](#)

[Other Operations](#)

[Notifications](#)

Power

[Notes on Sleep Mode](#)

Read the following precautions before using Sleep mode.

[Notes on Using the Power Source](#)

Read the following precautions before plugging your VAIO computer into an AC power source.

[Selecting a Power Plan](#)

Power management helps you set up power plans to suit your requirements for power consumption.

[Using Sleep Mode](#)

In Sleep mode, all unnecessary devices of your VAIO computer are turned off, though some devices stay on to retain the computer's state including data you are working on. Sleep mode is useful when you take a short rest, for example.

You might be looking for the following topics:

[Changing the Rapid Wake \(Sleep Mode\) Settings](#)

[Charge Indicator Status List](#)

[Charging the Battery Pack](#)

[Connecting a Power Source](#)

[Installing/Removing the Battery Pack](#)

[Restarting Your VAIO Computer](#)

[Shutting Down Your VAIO Computer](#)

[Turning on Your VAIO Computer](#)

[▶ Troubleshooting](#)

How to Use

[Parts Description](#)

[Setup](#)

[Network / Internet](#)

[Connections](#)

[Settings](#)

[Backup / Recovery](#)

[Security](#)

[Other Operations](#)

[Notifications](#)

Service and support

[Keeping Your VAIO Computer in Optimum Condition \(VAIO Care\)](#)

With VAIO Care, you can perform the following operations to keep your VAIO computer running at an optimum level.

[Updating Your VAIO Computer](#)

Be sure to update your VAIO computer with the following software applications to enhance the computer's efficiency, security, and functionality.

[Using VAIO Update](#)

VAIO Update provides a service that informs you of available update information, such as important notices or update programs, to keep your VAIO computer up to date.

You might be looking for the following topics:

[About Online Support Website](#)[Solving Common Problems with Your VAIO Computer](#)

[▶ Troubleshooting](#)

How to Use

[Parts Description](#)

[Setup](#)

[Network / Internet](#)

[Connections](#)

[Settings](#)

[Backup / Recovery](#)

[Security](#)

[Other Operations](#)

[Notifications](#)

Touch pad

[Disabling the Tapping Function on the Touch Pad](#)

You can disable the tapping function to avoid unintentional movements of the pointer caused by a light touch on the touch pad.

[Enabling/Disabling the Multi-Touch Function](#)

You can enable/disable the multi-touch function of the touch pad on your VAIO computer.

[Enabling/Disabling the Touch Pad](#)

You can enable/disable the touch pad on your VAIO computer.

[Using the Touch Pad](#)

By sliding your finger on the touch pad, you can move the pointer on the computer screen.

[▶ Troubleshooting](#)

How to Use

[Parts Description](#)

[Setup](#)

[Network / Internet](#)

[Connections](#)

[Settings](#)

[Backup / Recovery](#)

[Security](#)

[Other Operations](#)

[Notifications](#)

BIOS

[Booting Your VAIO Computer from External Devices](#)

You can boot your VAIO computer from external devices, such as an optical disc drive or a USB floppy disk drive, by using the BIOS function.

[Removing the Power-on Password](#)

If power-on password input for booting up your VAIO computer is no longer necessary, follow these steps to remove the machine password and user password.

[Setting/Changing the Power-on Password](#)

You can set a password (power-on password) for booting up your VAIO computer, using the BIOS function. Entry of the power-on password will be prompted after the VAIO logo appears to start the computer.

[▶ Troubleshooting](#)

How to Use

[Parts Description](#)

[Setup](#)

[Network / Internet](#)

[Connections](#)

[Settings](#)

[Backup / Recovery](#)

[Security](#)

[Other Operations](#)

[Notifications](#)

Button

[Changing the Button Assignment \(VAIO Button\)](#)

You can change the current task assigned to the VAIO button. [\[Details\]](#)

You might be looking for the following topics:

[About the ASSIST Button](#)

[▶ Troubleshooting](#)

How to Use

[Parts Description](#)

[Setup](#)

[Network / Internet](#)

[Connections](#)[Settings](#)[Backup / Recovery](#)

[Security](#)

[Other Operations](#)

[Notifications](#)

Camera

[Using the Built-in Camera<Built-in camera equipped models>](#)

If your VAIO computer is equipped with a built-in camera, you can make a video call through the Internet using communication software, such as Windows Live Messenger. For detailed information on how to use the software, refer to the help file included with the software.

You might be looking for the following topics:

[Notes on the Built-in Camera<Built-in camera equipped models>](#)

[▶ Troubleshooting](#)

How to Use

[Parts Description](#)

[Setup](#)

[Network / Internet](#)

[Connections](#)[Settings](#)[Backup / Recovery](#)

[Security](#)

[Other Operations](#)

[Notifications](#)

HDMI

[Changing the Resolution \(Size\) of the Screen Image on an HDMI-Connected Device](#)

You can change the screen resolution or size of your VAIO computer's screen image displayed on an external display, such as a TV, connected to the computer with an HDMI cable (not supplied).

[Connecting a TV with an HDMI Input Port](#)

You can connect a TV with an HDMI input port to your VAIO computer with an HDMI cable (not supplied).

[▶ Troubleshooting](#)

How to Use

[Parts Description](#)

[Setup](#)

[Network / Internet](#)

[Connections](#)[Settings](#)[Backup / Recovery](#)

[Security](#)

[Other Operations](#)

[Notifications](#)

Memory module

[Viewing the System Information](#)

You can view the system information of your VAIO computer.

You might be looking for the following topics:

[Adding and Removing Memory Modules](#)[Notes on Adding and Removing Memory Modules](#)

[▶ Troubleshooting](#)

How to Use

[Parts Description](#)

[Setup](#)

[Network / Internet](#)

[Connections](#)

[Settings](#)

[Backup / Recovery](#)

[Security](#)

[Other Operations](#)

[Notifications](#)

Optical digital output

[Connecting a High-Quality Digital Sound Output Device between Your VAIO Computer and a TV](#)

You can connect a high-quality home theater receiver or other surround sound decoder devices between your VAIO computer and a TV using an HDMI connection.

[▶ Troubleshooting](#)

How to Use

[Parts Description](#)

[Setup](#)

[Network / Internet](#)

[Connections](#)

[Settings](#)

[Backup / Recovery](#)

[Security](#)

[Other Operations](#)

[Notifications](#)

Peripheral device

[Changing the Sound Output Device](#)

If there is no sound from the device connected to your VAIO computer, you need to change the device for sound output.

[Connecting a High-Quality Digital Sound Output Device between Your VAIO Computer and a TV](#)

You can connect a high-quality home theater receiver or other surround sound decoder devices between your VAIO computer and a TV using an HDMI connection.

[Connecting a TV with an HDMI Input Port](#)

You can connect a TV with an HDMI input port to your VAIO computer with an HDMI cable (not supplied).

[Connecting an External Display or Projector](#)

You can connect an external display (such as a computer display or a projector) to your VAIO computer with a display cable (not supplied).

[Notes on the LCD screen](#)

Read the following precautions for correct use of the LCD screen.

[Selecting Display Modes](#)

You can switch the display output between the computer screen and an external display connected to your VAIO computer.

[Using the Multiple Monitors Function](#)

The Multiple Monitors function allows you to distribute portions of your desktop across separate displays.

You might be looking for the following topics:

[Connecting an External Microphone](#)

[▶ Troubleshooting](#)

How to Use

[Parts Description](#)

[Setup](#)

[Network / Internet](#)

[Connections](#)

[Settings](#)

[Backup / Recovery](#)

[Security](#)

[Other Operations](#)

[Notifications](#)

Security

Updating Your VAIO Computer

Be sure to update your VAIO computer with the following software applications to enhance the computer's efficiency, security, and functionality.

[▶ Troubleshooting](#)

How to Use

[Parts Description](#)

[Setup](#)

[Network / Internet](#)

[Connections](#)

[Settings](#)

[Backup / Recovery](#)

[Security](#)

[Other Operations](#)

[Notifications](#)

Speakers

[Adjusting the Speakers Volume](#)

You can change the volume level of the speakers and headphones.

You might be looking for the following topics:

[Connecting External Speakers or Headphones](#)

[▶ Troubleshooting](#)

How to Use

[Parts Description](#)

[Setup](#)

[Network / Internet](#)

[Connections](#)

[Settings](#)

[Backup / Recovery](#)

[Security](#)

[Other Operations](#)

[Notifications](#)

VAIO computer

[Booting Your VAIO Computer from External Devices](#)

You can boot your VAIO computer from external devices, such as an optical disc drive or a USB floppy disk drive, by using the BIOS function.

[Customizing Your VAIO Computer](#)

VAIO Control Center allows you to access system information and to change settings of various kinds of functions such as display and sounds.

[Keeping Your VAIO Computer in Optimum Condition \(VAIO Care\)](#)

With VAIO Care, you can perform the following operations to keep your VAIO computer running at an optimum level.

[Updating Your VAIO Computer](#)

Be sure to update your VAIO computer with the following software applications to enhance the computer's efficiency, security, and functionality.

[Using VAIO Update](#)

VAIO Update provides a service that informs you of available update information, such as important notices or update programs, to keep your VAIO computer up to date.

[Viewing the System Information](#)

You can view the system information of your VAIO computer.

You might be looking for the following topics:

[About the ASSIST Button](#)[Adding and Removing Memory Modules](#)[Checking Supplied Items](#)[Notes on Adding and Removing Memory Modules](#)[Parts and Controls on the Bottom](#)[Parts and Controls on the Front](#)[Parts and Controls on the Sides](#)[Setting Up an Appropriate Work Environment](#)

[▶ Troubleshooting](#)

How to Use

[Parts Description](#)

[Setup](#)

[Network / Internet](#)

[Connections](#)

[Settings](#)

[Backup / Recovery](#)

[Security](#)

[Other Operations](#)

[Notifications](#)

BIOS

[Booting Your VAIO Computer from External Devices](#)

You can boot your VAIO computer from external devices, such as an optical disc drive or a USB floppy disk drive, by using the BIOS function.

You might be looking for the following topics:

[Removing the Power-on Password](#)[Setting/Changing the Power-on Password](#)

[▶ Troubleshooting](#)

How to Use

[Parts Description](#)

[Setup](#)

[Network / Internet](#)

[Connections](#)

[Settings](#)

[Backup / Recovery](#)

[Security](#)

[Other Operations](#)

[Notifications](#)

Built-in storage device

[Checking the Volume of the Recovery Area](#)

Your built-in storage device contains the recovery area where the data for the system recovery is stored.

[Creating Other Drives \(Modifying Partitions\)](#)

Partitions are divided areas on your built-in storage device. Dividing the built-in storage device into more than one partition may have various advantages, such as separating the system files from your data files.

[Creating Partitions during Recovery](#)

This topic describes how to create partitions.

[Creating Partitions in Windows](#)

The Windows feature allows you to create a partition without recovering your VAIO computer system.

[Removing Recovery Contents to Free up Disk Space](#)

Your built-in storage device contains the recovery area where the data for system recovery is stored. If your VAIO computer includes a solid state drive (SSD), you might want to minimize the recovery area by removing such data.

[▶ Troubleshooting](#)

How to Use

[Parts Description](#)

[Setup](#)

[Network / Internet](#)

[Connections](#)

[Settings](#)[Backup / Recovery](#)[Security](#)

[Other Operations](#)

[Notifications](#)

CD/DVD/BD

[Booting Your VAIO Computer from External Devices](#)

You can boot your VAIO computer from external devices, such as an optical disc drive or a USB floppy disk drive, by using the BIOS function.

You might be looking for the following topics:

[Connecting an External DVD Drive](#)

[▶ Troubleshooting](#)

How to Use

[Parts Description](#)

[Setup](#)

[Network / Internet](#)

[Connections](#)

[Settings](#)

[Backup / Recovery](#)

[Security](#)

[Other Operations](#)

[Notifications](#)

Recovery

[About Recovery](#)

Recovery is the process of restoring your VAIO computer back to its original factory condition.

[About the ASSIST Button](#)

Press the ASSIST button to perform regular maintenance of your VAIO computer or to solve problems you might encounter when using the computer.

[Checking the Volume of the Recovery Area](#)

Your built-in storage device contains the recovery area where the data for the system recovery is stored.

[Creating Recovery Media](#)

Follow the instructions below to create Recovery Media.

[Notes on Recovery](#)

Read the following notes thoroughly before recovering your VAIO computer.

[Recovering from Recovery Media](#)

If the recovery area data has been corrupted or erased, you can use Recovery Media to recover your VAIO computer. However, it takes longer time to recover using Recovery Media than using the recovery area.

[Recovering from the Recovery Area](#)

Recovery from the recovery area on the built-in storage device is faster than recovery using Recovery Media.

[Removing Recovery Contents to Free up Disk Space](#)

Your built-in storage device contains the recovery area where the data for system recovery is stored. If your VAIO computer includes a solid state drive (SSD), you might want to minimize the recovery area by removing such data.

[▶ Troubleshooting](#)

How to Use

[Parts Description](#)

[Setup](#)

[Network / Internet](#)

[Connections](#)

[Settings](#)[Backup / Recovery](#)[Security](#)

[Other Operations](#)

[Notifications](#)

VAIO computer

[About the ASSIST Button](#)

Press the ASSIST button to perform regular maintenance of your VAIO computer or to solve problems you might encounter when using the computer.

[Booting Your VAIO Computer from External Devices](#)

You can boot your VAIO computer from external devices, such as an optical disc drive or a USB floppy disk drive, by using the BIOS function.

[Keeping Your VAIO Computer in Optimum Condition \(VAIO Care\)](#)

With VAIO Care, you can perform the following operations to keep your VAIO computer running at an optimum level.

You might be looking for the following topics:

[Adding and Removing Memory Modules](#)[Checking Supplied Items](#)[Customizing Your VAIO Computer](#)[Notes on Adding and Removing Memory Modules](#)[Parts and Controls on the Bottom](#)[Parts and Controls on the Front](#)[Parts and Controls on the Sides](#)[Setting Up an Appropriate Work Environment](#)[Updating Your VAIO Computer](#)[Using VAIO Update](#)[Viewing the System Information](#)

[▶ Troubleshooting](#)

How to Use

[Parts Description](#)

[Setup](#)

[Network / Internet](#)

[Connections](#)

[Settings](#)

[Backup / Recovery](#)

[Security](#)

[Other Operations](#)

[Notifications](#)

Backup

[About Backup](#)

The backup process creates a backup copy of your data stored on the built-in storage device and saves it to another location.

[About Types of Backup](#)

You can use the Windows Backup and Restore feature to back up your valuable data.

[Backing Up Your Data when You cannot Start Windows](#)

If you cannot start Windows, back up your data with VAIO Care Rescue.

[Creating a Restore Point](#)

A restore point enables you to restore your computer system files to a previous state, depending on when the restore point was created.

[Restoring System Files Using the Restore Point when You cannot Start Windows](#)

When you cannot start Windows, follow these steps to restore computer system files.

[Restoring Your Data with VAIO Data Restore Tool](#)

If you backed up files previously using VAIO Care Rescue, use VAIO Data Restore Tool to restore these files.

[▶ Troubleshooting](#)

How to Use

[Parts Description](#)

[Setup](#)

[Network / Internet](#)

[Connections](#)

[Settings](#)[Backup / Recovery](#)[Security](#)

[Other Operations](#)

[Notifications](#)

Button

[About the ASSIST Button](#)

Press the ASSIST button to perform regular maintenance of your VAIO computer or to solve problems you might encounter when using the computer.

You might be looking for the following topics:

[Changing the Button Assignment \(VAIO Button\)](#)

[▶ Troubleshooting](#)

How to Use

[Parts Description](#)

[Setup](#)

[Network / Internet](#)

[Connections](#)

[Settings](#)

[Backup / Recovery](#)

[Security](#)

[Other Operations](#)

[Notifications](#)

Partition

[Creating Other Drives \(Modifying Partitions\)](#)

Partitions are divided areas on your built-in storage device. Dividing the built-in storage device into more than one partition may have various advantages, such as separating the system files from your data files.

[Creating Partitions during Recovery](#)

This topic describes how to create partitions.

[Creating Partitions in Windows](#)

The Windows feature allows you to create a partition without recovering your VAIO computer system.

[▶ Troubleshooting](#)

How to Use

[Parts Description](#)

[Setup](#)

[Network / Internet](#)

[Connections](#)

[Settings](#)[Backup / Recovery](#)[Security](#)

[Other Operations](#)

[Notifications](#)

Service and support

[Keeping Your VAIO Computer in Optimum Condition \(VAIO Care\)](#)

With VAIO Care, you can perform the following operations to keep your VAIO computer running at an optimum level.

You might be looking for the following topics:

[About Online Support Website](#)[Solving Common Problems with Your VAIO Computer](#)[Updating Your VAIO Computer](#)[Using VAIO Update](#)

[▶ Troubleshooting](#)

How to Use

[Parts Description](#)

[Setup](#)

[Network / Internet](#)

[Connections](#)

[Settings](#)

[Backup / Recovery](#)

[Security](#)

[Other Operations](#)

[Notifications](#)

BIOS

[Removing the Power-on Password](#)

If power-on password input for booting up your VAIO computer is no longer necessary, follow these steps to remove the machine password and user password.

[Setting/Changing the Power-on Password](#)

You can set a password (power-on password) for booting up your VAIO computer, using the BIOS function. Entry of the power-on password will be prompted after the VAIO logo appears to start the computer.

You might be looking for the following topics:

[Booting Your VAIO Computer from External Devices](#)

[▶ Troubleshooting](#)

How to Use

[Parts Description](#)

[Setup](#)

[Network / Internet](#)

[Connections](#)

[Settings](#)

[Backup / Recovery](#)

[Security](#)

[Other Operations](#)

[Notifications](#)

Password

[Creating/Changing/Removing Your Windows Password](#)

Setting the Windows password allows you to protect your VAIO computer from unauthorized access by making the user enter the password when the computer is turned on or returns from power saving mode to Normal mode.

[Removing the Power-on Password](#)

If power-on password input for booting up your VAIO computer is no longer necessary, follow these steps to remove the machine password and user password.

[Setting/Changing the Power-on Password](#)

You can set a password (power-on password) for booting up your VAIO computer, using the BIOS function. Entry of the power-on password will be prompted after the VAIO logo appears to start the computer.

[▶ Troubleshooting](#)

How to Use

[Parts Description](#)

[Setup](#)

[Network / Internet](#)

[Connections](#)

[Settings](#)

[Backup / Recovery](#)

[Security](#)

[Other Operations](#)

[Notifications](#)

VAIO computer

[Keeping Your VAIO Computer in Optimum Condition \(VAIO Care\)](#)

With VAIO Care, you can perform the following operations to keep your VAIO computer running at an optimum level.

[Using VAIO Update](#)

VAIO Update provides a service that informs you of available update information, such as important notices or update programs, to keep your VAIO computer up to date.

You might be looking for the following topics:

[About the ASSIST Button](#)[Adding and Removing Memory Modules](#)[Booting Your VAIO Computer from External Devices](#)[Checking Supplied Items](#)[Customizing Your VAIO Computer](#)[Notes on Adding and Removing Memory Modules](#)[Parts and Controls on the Bottom](#)[Parts and Controls on the Front](#)[Parts and Controls on the Sides](#)[Setting Up an Appropriate Work Environment](#)[Updating Your VAIO Computer](#)[Viewing the System Information](#)

[▶ Troubleshooting](#)

How to Use

[Parts Description](#)

[Setup](#)

[Network / Internet](#)

[Connections](#)

[Settings](#)

[Backup / Recovery](#)

[Security](#)

[Other Operations](#)

[Notifications](#)

Internet

[Launching the Web Browser \(WEB Button\)](#)

By pressing the WEB button, you can launch the default web browser.

[Using the Antivirus Software for Your VAIO Computer](#)

Protect your VAIO computer against computer viruses by using the antivirus software.

You might be looking for the following topics:

[About a Security Key for a Wireless LAN](#)[About the Internet Connection Services](#)[About the Network \(LAN\)](#)[About the Wireless LAN Standards](#)[Before Using the Wireless LAN](#)[Connecting to the Internet with a Wired Connection](#)[Notes on Using the Wireless LAN Function](#)[Starting Wireless LAN Communications](#)[Stopping Wireless LAN Communications](#)

[▶ Troubleshooting](#)

How to Use

[Parts Description](#)

[Setup](#)

[Network / Internet](#)

[Connections](#)

[Settings](#)

[Backup / Recovery](#)

[Security](#)

[Other Operations](#)

[Notifications](#)

Service and support

[Keeping Your VAIO Computer in Optimum Condition \(VAIO Care\)](#)

With VAIO Care, you can perform the following operations to keep your VAIO computer running at an optimum level.

[Using VAIO Update](#)

VAIO Update provides a service that informs you of available update information, such as important notices or update programs, to keep your VAIO computer up to date.

You might be looking for the following topics:

[About Online Support Website](#)

[Solving Common Problems with Your VAIO Computer](#)

[Updating Your VAIO Computer](#)

[▶ Troubleshooting](#)

How to Use

[Parts Description](#)

[Setup](#)

[Network / Internet](#)

[Connections](#)

[Settings](#)

[Backup / Recovery](#)

[Security](#)

[Other Operations](#)

[Notifications](#)

Battery

[Changing the Rapid Wake \(Sleep Mode\) Settings](#)

You can change the Rapid Wake settings on VAIO Control Center.

[Charge Indicator Status List](#)

The charge indicator light turns on or blinks differently according to conditions.

[Charging the Battery Pack](#)

The battery pack can be charged even while you are using your VAIO computer when the computer is connected to a power source.

[Checking the Battery Charge Capacity](#)

The battery pack is consumable. The capacity gradually declines through repeated cycles of recharging and discharging. As a result, the battery life becomes short even if it is fully charged and eventually the battery pack reaches the end of its life.

[Extending the Battery Life](#)

When your VAIO computer is running on battery power, you can extend the battery life using the following methods.

You might be looking for the following topics:

[Installing/Removing the Battery Pack](#)

[Notes on Using the Battery Pack](#)

[▶ Troubleshooting](#)

How to Use

[Parts Description](#)

[Setup](#)

[Network / Internet](#)

[Connections](#)

[Settings](#)

[Backup / Recovery](#)

[Security](#)

[Other Operations](#)

[Notifications](#)

Camera

[Notes on the Built-in Camera<Built-in camera equipped models>](#)[Using the Built-in Camera<Built-in camera equipped models>](#)

If your VAIO computer is equipped with a built-in camera, you can make a video call through the Internet using communication software, such as Windows Live Messenger. For detailed information on how to use the software, refer to the help file included with the software.

[▶ Troubleshooting](#)

How to Use

[Parts Description](#)

[Setup](#)

[Network / Internet](#)

[Connections](#)

[Settings](#)

[Backup / Recovery](#)

[Security](#)

[Other Operations](#)

[Notifications](#)

Memory card

About “Memory Stick”

“Memory Stick” is a compact, portable, and versatile IC recording media especially designed for exchanging and sharing digital data with compatible products, such as digital cameras and other devices. Because it is removable, it can be used for external data storage.

Compatible “Memory Stick”

The “Memory Stick” slot on your VAIO computer can accommodate the following sizes and types of media:

Formatting “Memory Stick”

“Memory Stick” is formatted in the specific FAT format by default and is ready for use. Be sure to use the device that is designed to format the media and supports “Memory Stick” when formatting the media.

Inserting/Removing SD Memory Cards

Your VAIO computer is equipped with an SD memory card slot. You can use this slot to transfer data among digital cameras, camcorders, music players, and other audio/video devices.

Inserting/Removing “Memory Stick”

You can use “Memory Stick” to save data or transfer images between a digital camera and your VAIO computer. To insert/remove “Memory Stick”, follow these steps.

Notes on Using SD Memory Cards

Before using SD memory cards, read the following precautions for correct use.

Notes on Using “Memory Stick”

Before using “Memory Stick”, read the following precautions for correct use.

[▶ Troubleshooting](#)

How to Use

[Parts Description](#)

[Setup](#)

[Network / Internet](#)

[Connections](#)

[Settings](#)

[Backup / Recovery](#)

[Security](#)

[Other Operations](#)

[Notifications](#)

Partition

[Creating Other Drives \(Modifying Partitions\)](#)

Partitions are divided areas on your built-in storage device. Dividing the built-in storage device into more than one partition may have various advantages, such as separating the system files from your data files.

[Creating Partitions during Recovery](#)

This topic describes how to create partitions.

[Creating Partitions in Windows](#)

The Windows feature allows you to create a partition without recovering your VAIO computer system.

[▶ Troubleshooting](#)

How to Use

[Parts Description](#)

[Setup](#)

[Network / Internet](#)

[Connections](#)

[Settings](#)

[Backup / Recovery](#)

[Security](#)

[Other Operations](#)

[Notifications](#)

Touch pad

Using the Touch Pad

By sliding your finger on the touch pad, you can move the pointer on the computer screen.

You might be looking for the following topics:

[Disabling the Tapping Function on the Touch Pad](#)[Enabling/Disabling the Multi-Touch Function](#)[Enabling/Disabling the Touch Pad](#)

[▶ Troubleshooting](#)

How to Use

[Parts Description](#)

[Setup](#)

[Network / Internet](#)

[Connections](#)

[Settings](#)

[Backup / Recovery](#)

[Security](#)

[Other Operations](#)

[Notifications](#)

VAIO computer

[Adding and Removing Memory Modules](#)

If you want to increase your computer's speed or improve performance when running programs simultaneously, increase the amount of memory by installing optional memory modules.

[Notes on Adding and Removing Memory Modules](#)

Before adding or removing memory modules, read the following precautions thoroughly.

You might be looking for the following topics:

[About the ASSIST Button](#)[Booting Your VAIO Computer from External Devices](#)[Checking Supplied Items](#)[Customizing Your VAIO Computer](#)[Keeping Your VAIO Computer in Optimum Condition \(VAIO Care\)](#)[Parts and Controls on the Bottom](#)[Parts and Controls on the Front](#)[Parts and Controls on the Sides](#)[Setting Up an Appropriate Work Environment](#)[Updating Your VAIO Computer](#)[Using VAIO Update](#)[Viewing the System Information](#)

[▶ Troubleshooting](#)

How to Use

[Parts Description](#)

[Setup](#)

[Network / Internet](#)

[Connections](#)

[Settings](#)

[Backup / Recovery](#)

[Security](#)

[Other Operations](#)

[Notifications](#)

Built-in storage device

[Creating Other Drives \(Modifying Partitions\)](#)

Partitions are divided areas on your built-in storage device. Dividing the built-in storage device into more than one partition may have various advantages, such as separating the system files from your data files.

[Creating Partitions during Recovery](#)

This topic describes how to create partitions.

[Creating Partitions in Windows](#)

The Windows feature allows you to create a partition without recovering your VAIO computer system.

You might be looking for the following topics:

[Checking the Volume of the Recovery Area](#)

[Removing Recovery Contents to Free up Disk Space](#)

[▶ Troubleshooting](#)

How to Use

[Parts Description](#)

[Setup](#)

[Network / Internet](#)

[Connections](#)

[Settings](#)

[Backup / Recovery](#)

[Security](#)

[Other Operations](#)

[Notifications](#)

Keyboard

[Combinations and Functions with the Fn Key](#)

Press and hold down the Fn key and another key simultaneously to perform a keyboard shortcut action.

You might be looking for the following topics:

[Changing the Button Assignment \(VAIO Button\)](#)

[▶ Troubleshooting](#)

How to Use

[Parts Description](#)

[Setup](#)

[Network / Internet](#)

[Connections](#)

[Settings](#)

[Backup / Recovery](#)

[Security](#)

[Other Operations](#)

[Notifications](#)

Memory module

[Adding and Removing Memory Modules](#)

If you want to increase your computer's speed or improve performance when running programs simultaneously, increase the amount of memory by installing optional memory modules.

[Notes on Adding and Removing Memory Modules](#)

Before adding or removing memory modules, read the following precautions thoroughly.

You might be looking for the following topics:

[Viewing the System Information](#)

[▶ Troubleshooting](#)

How to Use

[Parts Description](#)

[Setup](#)

[Network / Internet](#)

[Connections](#)

[Settings](#)

[Backup / Recovery](#)

[Security](#)

[Other Operations](#)

[Notifications](#)

Power

[Changing the Rapid Wake \(Sleep Mode\) Settings](#)

You can change the Rapid Wake settings on VAIO Control Center.

[Charge Indicator Status List](#)

The charge indicator light turns on or blinks differently according to conditions.

[Charging the Battery Pack](#)

The battery pack can be charged even while you are using your VAIO computer when the computer is connected to a power source.

[Restarting Your VAIO Computer](#)

After changing the settings or installing software on your VAIO computer, you may be required to restart the computer.

[Shutting Down Your VAIO Computer](#)

Shut down your VAIO computer properly to avoid losing unsaved data.

[Turning on Your VAIO Computer](#)

Turn on your VAIO computer to start Windows. Carefully read the precautions in Notes on Using the Power Source before turning on. [Details]

[Using Sleep Mode](#)

In Sleep mode, all unnecessary devices of your VAIO computer are turned off, though some devices stay on to retain the computer's state including data you are working on. Sleep mode is useful when you take a short rest, for example.

You might be looking for the following topics:

[Connecting a Power Source](#)[Installing/Removing the Battery Pack](#)[Notes on Sleep Mode](#)[Notes on Using the Power Source](#)[Selecting a Power Plan](#)

[▶ Troubleshooting](#)

How to Use

[Parts Description](#)

[Setup](#)

[Network / Internet](#)

[Connections](#)

[Settings](#)

[Backup / Recovery](#)

[Security](#)

[Other Operations](#)

[Notifications](#)

USB

Charging a USB Device

You can charge a USB device even while your VAIO computer is off, in Hibernate mode, or Sleep mode by enabling the USB charging settings.

Connecting a USB Device

You can connect a Universal Serial Bus (USB) device such as a mouse, floppy disk drive, speaker or printer to your VAIO computer. Installation of the device driver software supplied with the USB device may be required when connecting. Refer to the manual that came with the device for more information.

[▶ Troubleshooting](#)

How to Use

[Parts Description](#)

[Setup](#)

[Network / Internet](#)

[Connections](#)

[Settings](#)

[Backup / Recovery](#)

[Security](#)

[Other Operations](#)

[Notifications](#)

Care and maintenance

[Cleaning Your VAIO computer/LCD screen](#)

Before cleaning your VAIO computer, read the following precautions for the correct cleaning procedure.

[▶ Troubleshooting](#)

How to Use

[Parts Description](#)

[Setup](#)

[Network / Internet](#)

[Connections](#)

[Settings](#)

[Backup / Recovery](#)

[Security](#)

[Other Operations](#)

[Notifications](#)

Product registration

[About Online Support Website](#)

The online support website provides information about frequently asked questions about your VAIO computer.

[▶ Troubleshooting](#)

How to Use

[Parts Description](#)

[Setup](#)

[Network / Internet](#)

[Connections](#)

[Settings](#)

[Backup / Recovery](#)

[Security](#)

[Other Operations](#)[Notifications](#)

Security

Updating Your VAIO Computer

Be sure to update your VAIO computer with the following software applications to enhance the computer's efficiency, security, and functionality.

[▶ Troubleshooting](#)

How to Use

[Parts Description](#)

[Setup](#)

[Network / Internet](#)

[Connections](#)

[Settings](#)

[Backup / Recovery](#)

[Security](#)

[Other Operations](#)

[Notifications](#)

Supplied items

Checking Supplied Items

Check all items packed with the product before use.

[▶ Troubleshooting](#)

How to Use

[Parts Description](#)

[Setup](#)

[Network / Internet](#)

[Connections](#)

[Settings](#)

[Backup / Recovery](#)

[Security](#)

[Other Operations](#)

[Notifications](#)

Important notice

[About the International ENERGY STAR\(R\) Program](#)

The following information is applicable to ENERGY STAR qualified products only.

[About the Software License](#)

This product contains software owned by Sony and licensed by third parties. Use of such software is subject to the terms and conditions of license agreements enclosed with this product.

[Handling the Built-in Storage Device](#)

The built-in storage device (hard disk drive or solid state drive) has a high storage density and reads or writes data in a short time. However, it can be easily damaged if improperly used.

[Safety Information](#)

Refer to the supplied safety manual for detailed safety information.

[Trademarks](#)

[▶ Troubleshooting](#)

How to Use

[Parts Description](#)

[Setup](#)

[Network / Internet](#)

[Connections](#)

[Settings](#)

[Backup / Recovery](#)

[Security](#)

[Other Operations](#)[Notifications](#)

Read this first

[Read This First](#)

Congratulations on your purchase of this VAIO(R) computer and welcome to the on-screen User Guide.

[▶ Troubleshooting](#)

How to Use

[Parts Description](#)

[Setup](#)

[Network / Internet](#)

[Connections](#)

[Settings](#)

[Backup / Recovery](#)

[Security](#)

[Other Operations](#)

[Notifications](#)

Service and support

[About Online Support Website](#)

The online support website provides information about frequently asked questions about your VAIO computer.

[Solving Common Problems with Your VAIO Computer](#)

If you have any problem operating your VAIO computer, try these suggestions before contacting an authorized Sony service/support center or your local Sony dealer directly.

[Updating Your VAIO Computer](#)

Be sure to update your VAIO computer with the following software applications to enhance the computer's efficiency, security, and functionality.

You might be looking for the following topics:

[Keeping Your VAIO Computer in Optimum Condition \(VAIO Care\)](#)

[Using VAIO Update](#)

[▶ Troubleshooting](#)

How to Use

[Parts Description](#)

[Setup](#)

[Network / Internet](#)

[Connections](#)

[Settings](#)

[Backup / Recovery](#)

[Security](#)

[Other Operations](#)

[Notifications](#)

VAIO computer

[Checking Supplied Items](#)

Check all items packed with the product before use.

[Setting Up an Appropriate Work Environment](#)

This topic describes where to or not to place your VAIO computer and ergonomic instructions.

[Updating Your VAIO Computer](#)

Be sure to update your VAIO computer with the following software applications to enhance the computer's efficiency, security, and functionality.

You might be looking for the following topics:

[About the ASSIST Button](#)[Adding and Removing Memory Modules](#)[Booting Your VAIO Computer from External Devices](#)[Customizing Your VAIO Computer](#)[Keeping Your VAIO Computer in Optimum Condition \(VAIO Care\)](#)[Notes on Adding and Removing Memory Modules](#)[Parts and Controls on the Bottom](#)[Parts and Controls on the Front](#)[Parts and Controls on the Sides](#)[Using VAIO Update](#)[Viewing the System Information](#)



[> How to Use](#)

Troubleshooting

Hardware

Software

Network / Internet

Backup / Recovery

Security

Peripheral Devices

Hardware

[Audio](#)

[BLUETOOTH](#)

[Camera](#)

[Display](#)

[HDMI](#)

[LAN](#)

[Microphone](#)

[Power](#)

[Touch pad](#)

[Wireless LAN](#)

[BIOS](#)

[Battery](#)

[Computer](#)

[Floppy disk](#)

[Keyboard](#)

[Memory card](#)

[Password](#)

[Software](#)

[USB](#)

[▶ How to Use](#)

Troubleshooting

Hardware

Software

Network / Internet

Backup / Recovery

Security

Peripheral Devices

Software

[Display](#)

[Software](#)



[▶ How to Use](#)

Troubleshooting

Hardware

Software

Network / Internet

Backup / Recovery

Security

Peripheral Devices

Network / Internet

[BLUETOOTH](#)

[LAN](#)

[Wireless LAN](#)

[▶ How to Use](#)

Troubleshooting

Hardware

Software

Network / Internet

Backup / Recovery

Security

Peripheral Devices

Backup / Recovery

[Floppy disk](#)

[Recovery](#)

[USB](#)

[▶ How to Use](#)

Troubleshooting

Hardware

Software

Network / Internet

Backup / Recovery

Security

Peripheral Devices

Security

[BIOS](#)

[Password](#)

[▶ How to Use](#)

Troubleshooting

Hardware

Software

Network / Internet

Backup / Recovery

Security

Peripheral Devices

Peripheral Devices

[Floppy disk](#)

[Printer](#)

[USB](#)

[▶ Troubleshooting](#)

How to Use

[Parts Description](#)[Setup](#)[Network / Internet](#)[Connections](#)[Settings](#)[Backup / Recovery](#)[Security](#)[Other Operations](#)[Notifications](#)

About Online Support Website

The online support website provides information about frequently asked questions about your VAIO computer.

Sony online support website

- USA
<http://esupport.sony.com/EN/VAIO/>
- Canada
<http://www.sony.ca/support/> (English)
<http://fr.sony.ca/support/> (French)
- Spanish-speaking Latin American countries or areas
<http://esupport.sony.com/ES/VAIO/LA/>
- Brazil
<http://esupport.sony.com/PT/VAIO/BR/>

Hint

- If you experience any problem and have a technical question about your VAIO computer, launch VAIO Care first, which offers you various options to help you solve the problem.[\[Details\]](#)
- When you contact VAIO support, you may be asked for the serial number and the model number of your VAIO computer. The serial number is a 15-digit number that can be found:
 - in the VAIO Care window;
 - on the bottom, the back panel of the computer, inside the back panel or inside the battery compartment;
 - on the original VAIO box.

The model number is located at the lower right corner of the display on the VAIO computer.

Other websites

You can find other useful information from the following URL.

Sony products

<http://www.sony.net/>

<http://www.sony.net/electronics/>

Operating system online support website

For Microsoft Windows operating system support, visit the Microsoft customer support site.

<http://support.microsoft.com/>

In Store Service & Support (available in USA only)

Make an appointment with a Sony certified technician at a U.S. Sony Store and get personalized service and support for your VAIO computer. Sony Technicians can assist with the setup of your new VAIO computer, system optimization, data rescue, and any repair service you might need.

<http://www.sony.com/store/>

Hint

- You can find a link to register your computer online in VAIO Care. Click  (Start), All Programs, and VAIO Care.

Related Topic

[Read This First](#)

[Keeping Your VAIO Computer in Optimum Condition \(VAIO Care\)](#)

[▶ Troubleshooting](#)**How to Use**[Parts Description](#)[Setup](#)[Network / Internet](#)[Connections](#)[Settings](#)[Backup / Recovery](#)[Security](#)[Other Operations](#)[Notifications](#)

Welcome

Congratulations on the purchase of this VAIO(R) computer.

This User Guide - Introduction Version provides you with limited information about your VAIO computer. To update this file to the complete version of the User Guide, see [Updating the User Guide to the Latest Version \[Details\]](#) for more information.

[Updating the User Guide to the Latest Version](#)[Connecting to the Internet](#)[Updating Your VAIO Computer](#)[Solving Problems on Your VAIO Computer Using VAIO Care](#)[Finding Support Information](#)[Trademarks](#)[^ Go to top](#)

Updating the User Guide to the Latest Version

By updating this User Guide - Introduction Version through the Internet, you can get the complete version of the User Guide with detailed information on your VAIO computer. Once the User Guide is updated to the complete version, you can access it anytime even if you are offline.

With the complete version of the User Guide, you can view information about:

- Parts description
- Feature and operating instructions
- Precautions
- Troubleshooting information

Below is an example of a screenshot in English.



* Design and content of the screen are subject to change.

To get the complete version of the User Guide

1. Connect your VAIO computer to the Internet. [\[Details\]](#)
2. Close this window, and then click  (Start), All Programs, and VAIO Manual again.

3. A window prompting you to update the manual appears. Follow the on-screen instructions.
This file will automatically update to the complete version of the User Guide.
If the window prompting you to update the User Guide does not appear, make sure your VAIO computer is connected to the Internet and repeat the above steps.
If the update window still does not appear, launch VAIO Update so you can find and download the User Guide manually. See [Updating Your VAIO Computer \[Details\]](#) for more information on VAIO Update.

Hint

- It may take some time to complete the update.

To view help files for Windows OS and software operations

When you have trouble operating your VAIO computer, try referring to Windows Help and Support or help files included with your applications.

To access Windows Help and Support, click  (Start) and Help and Support.

[^ Go to top](#)

Connecting to the Internet

You will need to connect your VAIO computer to the Internet before updating to the complete version of the User Guide.

Before connecting to the Internet

Before using the Internet, you will need to sign up with an Internet Service Provider (ISP) and set up devices required for connecting your VAIO computer to the Internet.

The following types of Internet connection services may be available from your ISP:

- Fiber to the Home (FTTH)
- Digital Subscriber Line (DSL)
- Cable modem
- Satellite
- Dial-up

For more information on devices required for Internet access and how to connect your VAIO computer to the Internet, ask your ISP.

The following is one of the Internet connection methods as an example.

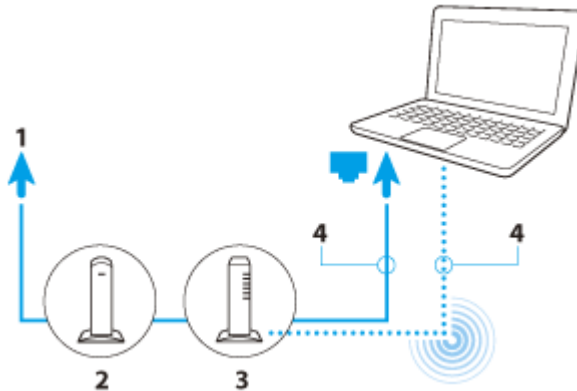

1. Internet
2. Modem
3. Router/access point
4. LAN cable (not supplied) or wireless LAN

To use the network (LAN)

You can connect your VAIO computer to networks with a LAN cable. Connect one end of a LAN cable to the LAN port on the computer and the other end to your network. For detailed settings and devices required for LAN access, ask your network administrator.

Note

- The connection, setting method, or required devices may vary depending on your network environment.

To use the wireless LAN network (Wi-Fi)

You first need to establish wireless LAN communications between your VAIO computer and an access point (not supplied). Refer to Windows Help and Support for more information.

To start wireless LAN communications with VAIO Easy Connect

You can easily set up wireless LAN communications by following the instructions in VAIO Easy Connect. VAIO Easy Connect supports you especially when you first set up a wireless Internet connection at home or when you connect to a public wireless network (Wi-Fi hotspot).

1. Click  (Start), All Programs, VAIO Easy Connect, and Easy Internet Connection Setup.
2. Follow the on-screen instructions to setup wireless LAN communications.

[^ Go to top](#)

Updating Your VAIO Computer

Be sure to update your VAIO computer with the following software applications to enhance the computer's efficiency, security, and functionality.

Note

- Your VAIO computer must be connected to the Internet to download the updates.

To use Windows Update

Windows Update enables you to make your VAIO computer more stable.

1. Click  (Start), All Programs, and Windows Update.
2. Follow the on-screen instructions.

To use VAIO Update

VAIO Update automatically notifies you of new updates available on the Internet then downloads and installs them on your VAIO computer.

1. Click  (Start), All Programs, and VAIO Care.
2. After VAIO Care starts, click VAIO Software and VAIO Update.
3. Follow the on-screen instructions.

To update antivirus software

Help protect your VAIO computer against security threats by keeping Internet security

programs current with the latest updates. You can download and install the updates from the website of the manufacturer.

1. Click  (Start), All Programs, and select the antivirus software.
2. Follow the on-screen instructions to complete the updates.

[^ Go to top](#)

Solving Problems on Your VAIO Computer Using VAIO Care

With VAIO Care, you can regularly conduct performance checks and system tune-ups on your VAIO computer to keep it running at optimum level. Launch VAIO Care whenever a problem arises.

VAIO Care will provide appropriate measures and support information to solve the problem.

To launch VAIO Care

Press the ASSIST button while your VAIO computer is on.
Below is an example of a screenshot in English.



* Design and content of the screen are subject to change.

Hint

- Alternatively, click  (Start), All Programs, and VAIO Care to launch VAIO Care.
- Refer to the help file included with VAIO Care for more information.
- Pressing the ASSIST button while your VAIO computer is off launches VAIO Care Rescue. VAIO Care Rescue can be used to recover the computer in case of emergency, for example, when Windows does not start.

[^ Go to top](#)

Finding Support Information

The Sony online support website provides instant access to information on commonly encountered problems. You can find support information such as the support website URL in Contact & Support on VAIO Care or the supplied Quick Start Guide.

[^ Go to top](#)

Trademarks

- SONY and the SONY logo are registered trademarks of Sony Corporation.

- VAIO, the VAIO logo, and other Sony product or service names are trademarks or registered trademarks of Sony Corporation or any of its affiliates.
- Windows and the Windows logo are either registered trademarks or trademarks of Microsoft Corporation in the United States and/or other countries.
- All other names of system, products, and services are trademarks of their respective owners.
- In the manual, the TM or (R) marks are not specified.

[^ Go to top](#)

Copyright 2012 Sony Corporation

[▶ Troubleshooting](#)

How to Use

[Parts Description](#)

[Setup](#)

[Network / Internet](#)

[Connections](#)

[Settings](#)

[Backup / Recovery](#)

[Security](#)

[Other Operations](#)

[Notifications](#)

Parts and Controls on the Bottom

Describes the features on the bottom of the VAIO computer.

- Air intake vents
- Battery connector [\[Details\]](#)
- Memory module compartment cover [\[Details\]](#)

Related Topic

[Parts and Controls on the Front](#)[Parts and Controls on the Sides](#)

[▶ Troubleshooting](#)

How to Use



- [Parts Description](#)
- [Setup](#)
- [Network / Internet](#)
- [Connections](#)
- [Settings](#)
- [Backup / Recovery](#)
- [Security](#)
- [Other Operations](#)
- [Notifications](#)

Parts and Controls on the Front

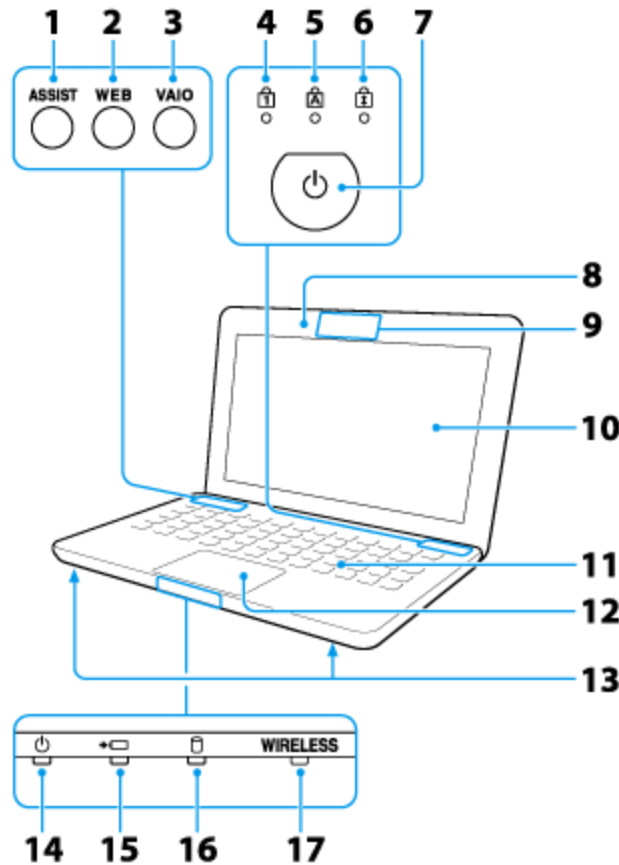
Describes the features on the front of the VAIO computer, such as buttons and indicator lights.



1. ASSIST button [\[Details\]](#)
2. WEB button [\[Details\]](#)
3. VAIO button [\[Details\]](#)
4. Num lock indicator
5. Caps lock indicator
6. Scroll lock indicator
7. Power button [\[Details\]](#)
8. Built-in microphone (monaural)
9. Built-in camera / Built-in camera indicator [\[Details\]](#)
10. LCD screen
11. Keyboard
12. Touch pad [\[Details\]](#)
13. Built-in speakers (stereo)
14. Power indicator [\[Details\]](#)

15.  Charge indicator [\[Details\]](#)
16.  Disc drive indicator
17. WIRELESS indicator [\[Details\]](#)

Related Topic

[Parts and Controls on the Sides](#)

[Parts and Controls on the Bottom](#)

[▶ Troubleshooting](#)

How to Use

- [Parts Description](#)
- [Setup](#)
- [Network / Internet](#)
- [Connections](#)
- [Settings](#)
- [Backup / Recovery](#)
- [Security](#)
- [Other Operations](#)
- [Notifications](#)



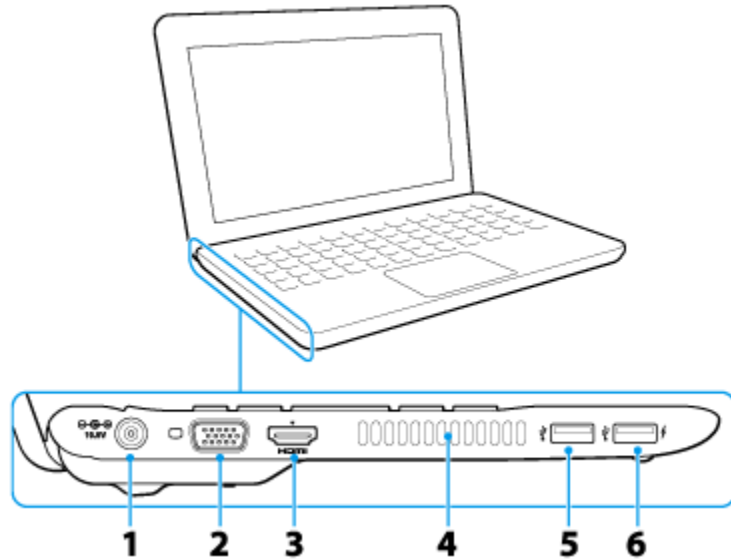

Parts and Controls on the Sides

Describes the features on the sides of the VAIO computer, such as connection ports.

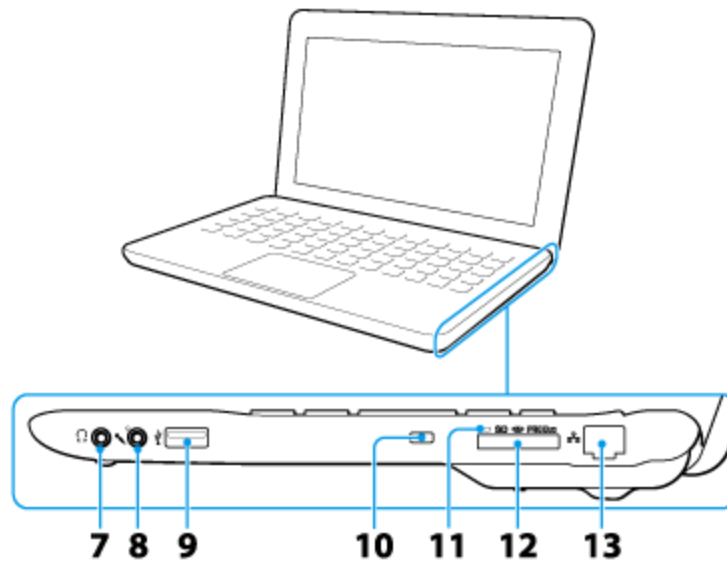

1. DC IN port [\[Details\]](#)
2. Monitor port [\[Details\]](#)
3. HDMI output port [\[Details\]](#)
4. Air exhaust vent
5. USB port [\[Details\]](#)
6. USB port [\[Details\]](#)
This USB port supports USB charging. [\[Details\]](#)



7.  Headphones jack [\[Details\]](#)
8.  Microphone jack [\[Details\]](#)
9.  USB port [\[Details\]](#)
10. Security slot
11. Media access indicator (“Memory Stick Duo” [\[Details\]](#), SD memory card [\[Details\]](#))
12. “Memory Stick Duo” / SD memory card combined slot (“Memory Stick Duo” [\[Details\]](#), SD memory card [\[Details\]](#))
“Memory Stick Duo” and an SD memory card cannot be inserted into the slot simultaneously.
13.  LAN port [\[Details\]](#)

Related Topic

[Parts and Controls on the Front](#)

[Parts and Controls on the Bottom](#)

[▶ Troubleshooting](#)

How to Use

[Parts Description](#)

[Setup](#)

[Network / Internet](#)

[Connections](#)

[Settings](#)

[Backup / Recovery](#)

[Security](#)

[Other Operations](#)

[Notifications](#)

About the ASSIST Button

Press the ASSIST button to perform regular maintenance of your VAIO computer or to solve problems you might encounter when using the computer.

While the computer is on, the ASSIST button starts VAIO Care.

While the computer is off, the ASSIST button starts VAIO Care Rescue.

VAIO Care Rescue can be used to recover the computer in case of emergency, for example, when Windows does not start.

Related Topic

[Keeping Your VAIO Computer in Optimum Condition \(VAIO Care\)](#)

[Recovering from the Recovery Area](#)

[Backing Up Your Data when You cannot Start Windows](#)

[Restoring Your Data with VAIO Data Restore Tool](#)

▶ Troubleshooting

How to Use

Parts Description

Setup

Network / Internet

Connections

Settings

Backup / Recovery

Security

Other Operations

Notifications

Adding and Removing Memory Modules

If you want to increase your computer's speed or improve performance when running programs simultaneously, increase the amount of memory by installing optional memory modules.

Before you upgrade your computer's memory, see Notes on Adding and Removing Memory Modules.[\[Details\]](#)

The type of module and the amount of memory installed on your computer may differ depending on the model.

1. Turn off your VAIO computer and peripheral devices, disconnect the power cord and all connection cables, and remove the battery pack.
2. Wait for a while until your VAIO computer cools down.
The inner parts of your VAIO computer may be hot just after turning off. Be careful to avoid burns while handling your VAIO computer in this state.
3. Lay a clean cloth on a level, flat surface, place your VAIO computer on it as illustrated below. Remove the screws with a cross slot screwdriver to open the memory module compartment cover.
The screw locations are indicated by the arrows in the illustration below.
On some models, captive screws are used on the memory module compartment cover and cannot be detached from the cover.

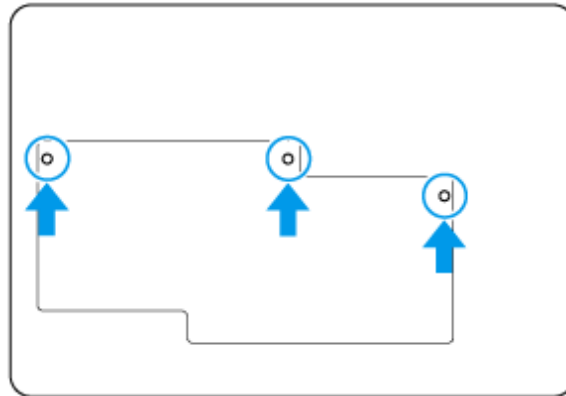

4. Touch an external metal object to discharge static electricity.
Do not touch any metal parts inside your VAIO computer.
5. If there is no free slot, remove the currently installed memory module. Pull the latches in the direction of the arrows to pop up the module at an angle (1), then pull the module out in the direction of the arrow (2).

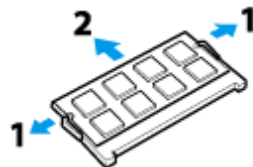

6. Remove the new memory module from its antistatic bag.
7. Hold the memory module by its edge and slide it into the memory module slot with its

end terminal facing downward while aligning the notch on the module with the small projection in the slot.



8. Hold the memory module by its edge and push in until it clicks into place as shown in the illustration.

The latches on both sides of the slot snap into place to secure the module. Do not touch any ICs (black components) on the memory module.

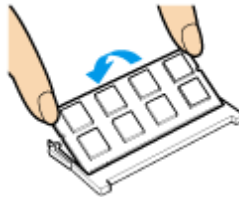

9. Replace the memory module compartment cover and secure it with the screws you removed in step 3.
10. Install the battery pack and connect all connection cables and peripherals that you removed in Step 1, and turn on the computer.
11. Check that the amount of system memory has correctly changed. [\[Details\]](#)
If the amount of indicated system memory is correct, memory module installation was successful.

Related Topic

[Notes on Adding and Removing Memory Modules](#)

[▶ Troubleshooting](#)

How to Use

[Parts Description](#)

[Setup](#)

[Network / Internet](#)

[Connections](#)

[Settings](#)

[Backup / Recovery](#)

[Security](#)

[Other Operations](#)

[Notifications](#)

Booting Your VAIO Computer from External Devices

You can boot your VAIO computer from external devices, such as an optical disc drive or a USB floppy disk drive, by using the BIOS function.

1. Connect an external device to your VAIO computer and turn on the computer.
2. Press the F11 key repeatedly until the VAIO logo disappears.
The booting process from the external device starts. If your VAIO computer does not boot up, restart the computer and try again.

Note

- Disconnect all devices from your VAIO computer except for the external device from which you intend to boot up. Some devices cannot be used to boot the computer, or cannot be used with the computer.
 - If an AC adapter is supplied with the external device, be sure to connect it to an AC power source in advance.
-

[▶ Troubleshooting](#)

How to Use

[Parts Description](#)

[Setup](#)

[Network / Internet](#)

[Connections](#)

[Settings](#)

[Backup / Recovery](#)

[Security](#)

[Other Operations](#)

[Notifications](#)

Checking Supplied Items

Check all items packed with the product before use.

AC adapter

Power cord

Battery pack

Hint

- No Recovery Media is included because your VAIO computer can be recovered using data stored in the hard disk drive or SSD. See Recovering from the Recovery Area for more information.[\[Details\]](#)
-

[▶ Troubleshooting](#)

How to Use

[Parts Description](#)

[Setup](#)

[Network / Internet](#)

[Connections](#)

[Settings](#)

[Backup / Recovery](#)

[Security](#)

[Other Operations](#)

[Notifications](#)

Customizing Your VAIO Computer

VAIO Control Center allows you to access system information and to change settings of various kinds of functions such as display and sounds.

1. Click  (Start), All Programs, and VAIO Control Center.
2. Select your desired item and change the settings.

Hint

- Refer to the help file included with VAIO Control Center for more information on each option.
 - Some of the items will not be visible if you log on as a user without administrative rights.
-

[▶ Troubleshooting](#)

How to Use

[Parts Description](#)

[Setup](#)

[Network / Internet](#)

[Connections](#)

[Settings](#)

[Backup / Recovery](#)

[Security](#)

[Other Operations](#)

[Notifications](#)

Keeping Your VAIO Computer in Optimum Condition (VAIO Care)

With VAIO Care, you can perform the following operations to keep your VAIO computer running at an optimum level.

- Conduct regular performance checks and tune-ups.
 - Find support information (the support website URL, the contact information phone number, etc.).
 - Launch VAIO Care just by pressing the ASSIST button and search for appropriate measures if you have any problem.
1. Press the ASSIST button while your VAIO computer is on.
VAIO Care starts.
Refer to the help file included with VAIO Care for more information.

Hint

- Alternatively, click  (Start), All Programs, and VAIO Care to start VAIO Care.
- Pressing the ASSIST button while your VAIO computer is off launches VAIO Care Rescue. VAIO Care Rescue can be used to recover the computer in case of emergency, for example, if Windows does not start.

Related Topic

[Recovering from the Recovery Area](#)[Backing Up Your Data when You cannot Start Windows](#)[Restoring Your Data with VAIO Data Restore Tool](#)

[▶ Troubleshooting](#)**How to Use**[Parts Description](#)[Setup](#)[Network / Internet](#)[Connections](#)[Settings](#)[Backup / Recovery](#)[Security](#)[Other Operations](#)[Notifications](#)

Notes on Adding and Removing Memory Modules

Before adding or removing memory modules, read the following precautions thoroughly.

- Your VAIO computer and memory modules use high precision components and electronic connector technology. To avoid invalidation of the warranty during your product warranty period, we recommend that:
 - You should contact your dealer to install a new memory module.
 - You should not install a memory module by yourself, if you are not familiar with upgrading memory on a computer.
 - You should not touch the connectors or open the memory module compartment cover.
- For assistance, contact an authorized Sony service/support center. To find the nearest center or agent, refer to online support website. [\[Details\]](#)
- If you add or remove memory modules by yourself, your VAIO computer may result in malfunction or accident caused by breakage of slot and module, or connection mistake. In this case, repair fee will be charged.
- Be careful not to injure your hands or fingers with sharp edges of the memory module, inner components, or circuit boards of your VAIO computer.
- Be careful not to catch your fingers on any inner cables of your VAIO computer, as the cable may become loose or disconnected.
- If your VAIO computer is turned on while liquid such as water or other foreign object remains inside, it may cause a fire. Be sure to remove any foreign objects and attach the memory module compartment cover before turning on your VAIO computer.
- Sony does not guarantee that third party memory modules will work in your VAIO computer. For information on third party memory modules, consult the respective sales dealers.
- Be sure to turn off your VAIO computer and peripherals and disconnect all attachments and connection cables before adding or removing memory modules. Failure to do so may cause damage to the memory module, your VAIO computer, or peripheral devices.
- To prevent damage from electrostatic discharge to memory modules, follow the instructions below:
 - Do not work at a place that produces static electricity easily, such as on a carpet.
 - Before adding or removing memory modules, touch an external metal object from your VAIO computer to eliminate static electricity. Do not touch any metal parts inside the computer.
 - Do not open the memory module package before you are ready to install the module. The package protects the module from ESD (electrostatic discharge). To store the module, cover it with an antistatic bag or a sheet of aluminum foil.
- When holding a memory module, do not touch the chips or electrical terminal of the module.
- Do not insert a memory module into the slot facing in wrong direction. It may cause damage to the module or slot, or cause the circuit board to catch fire.
- Use a screwdriver that matches the size of the screw (such as a miniature screwdriver).
- Do not remove or loosen screws that are not specified to be removed.

Related Topic

[Adding and Removing Memory Modules](#)[Viewing the System Information](#)

[▶ Troubleshooting](#)**How to Use**[Parts Description](#)[Setup](#)[Network / Internet](#)[Connections](#)[Settings](#)[Backup / Recovery](#)[Security](#)[Other Operations](#)[Notifications](#)

Setting Up an Appropriate Work Environment

This topic describes where to or not to place your VAIO computer and ergonomic instructions.

Where to place your VAIO computer

When placing your VAIO computer, ensure that:

- You have easy access to a power source and necessary ports.
- You leave enough space around the computer.
- The computer is placed on a flat surface that is wide enough and you can face the computer screen as you operate it.
- You can place the computer in front of you where you can sit upright and keep your forearms parallel to the floor.

Where not to place your VAIO computer

Placing your VAIO computer in an inappropriate location may cause damage or a malfunction. Do not place the computer in a location subject to:

- Direct sunlight
- Magnetic items or sources
- Heat sources, such as residential heating equipment
- Excessive dust
- High humidity
- Poor ventilation

Note

- The area around the air exhaust vent may become extremely hot while your VAIO computer is on. Be careful before touching the area.
- Do not place any object near the air exhaust vent that may block the vent.

Hint

- Your VAIO computer uses high-frequency radio signals and may cause interference to radio or TV reception. If this occurs, move the computer a suitable distance away from the radio or TV.

Ergonomic considerations

Whenever possible, you should attempt to take account of the following ergonomic considerations.

Furniture and posture

Sit in a chair with good back support. Adjust the level of the chair so your feet are flat on the floor. A footrest may make you more comfortable.

Sit in a relaxed, upright posture and avoid slouching forward or leaning far backwards.

Viewing angle of the computer screen

Use the screen tilting feature to find the best position. Make sure the computer screen is at or slightly below eye level when you are sitting in front of your VAIO computer. Adjust the

brightness level of the display as well.

You can reduce eye strain and muscle fatigue by adjusting the tilt and brightness level of the computer screen to the proper position.

Lighting

Choose a location where windows and lights do not cause glare and reflection on the computer screen. Use indirect lighting to avoid bright spots on the computer screen. Proper lighting adds to your comfort and work efficiency.

Note

- While adjusting the viewing angle, do not exert excessive pressure on your VAIO computer to eliminate a risk of mechanical damage.

Hint

- The same considerations apply when you use an external display.

Notes on handling your VAIO computer

Observe the following to avoid malfunctions and damage to your VAIO computer.

- Place your VAIO computer gently on a flat surface to avoid a mechanical shock.
 - Be sure to turn off your VAIO computer before moving the computer. Moving the computer that is turned on may cause a hard disk malfunction. Be sure to disconnect all cables connected to the computer before moving it.
 - Do not drop or hit your VAIO computer. Even a slight shock or vibration may cause a hard disk malfunction.
 - Do not place your VAIO computer in an unstable position.
-

[▶ Troubleshooting](#)

How to Use

[Parts Description](#)

[Setup](#)

[Network / Internet](#)

[Connections](#)

[Settings](#)

[Backup / Recovery](#)

[Security](#)

[Other Operations](#)

[Notifications](#)

Updating Your VAIO Computer

Be sure to update your VAIO computer with the following software applications to enhance the computer's efficiency, security, and functionality.

Note

- Your VAIO computer must be connected to the Internet to download the updates.

Windows Update

Windows Update enables you to make your VAIO computer more stable.

1. Click  (Start), All Programs, and Windows Update.
2. Follow the on-screen instructions.

VAIO Update

VAIO Update automatically notifies you of new updates available on the Internet, and downloads and installs them on your VAIO computer.

1. Click  (Start), All Programs, and VAIO Care.
2. After VAIO Care starts, click VAIO Software and VAIO Update.
Follow the on-screen instructions.

Related Topic

[Using VAIO Update](#)

[▶ Troubleshooting](#)

How to Use

[Parts Description](#)

[Setup](#)

[Network / Internet](#)

[Connections](#)

[Settings](#)

[Backup / Recovery](#)

[Security](#)

[Other Operations](#)

[Notifications](#)

Using VAIO Update

VAIO Update provides a service that informs you of available update information, such as important notices or update programs, to keep your VAIO computer up to date. Through the Internet, VAIO Update automatically detects the update programs that are necessary for enhancing your computer's performance or new software that is available, and let you download and install with simple steps.

1. Click  (Start), All Programs, and VAIO Care.
2. After VAIO Care starts, click VAIO Software and VAIO Update.
Follow the on-screen instructions.

Related Topic

[Keeping Your VAIO Computer in Optimum Condition \(VAIO Care\)](#)

[▶ Troubleshooting](#)

How to Use

[Parts Description](#)

[Setup](#)

[Network / Internet](#)

[Connections](#)

[Settings](#)

[Backup / Recovery](#)

[Security](#)

[Other Operations](#)

[Notifications](#)

Viewing the System Information

You can view the system information of your VAIO computer.

For example, after installing a memory module, you can view the information to confirm system memory changes.

1. Click  (Start), All Programs, and VAIO Control Center.
2. Click System Information and System Information.
The system information of your VAIO computer is displayed.

Related Topic

[Notes on Adding and Removing Memory Modules](#)
[Adding and Removing Memory Modules](#)

[▶ Troubleshooting](#)

How to Use



[Parts Description](#)[Setup](#)[Network / Internet](#)[Connections](#)[Settings](#)[Backup / Recovery](#)[Security](#)[Other Operations](#)[Notifications](#)

Charging the Battery Pack

The battery pack can be charged even while you are using your VAIO computer when the computer is connected to a power source. The charging time may vary depending on operating conditions.

1. Install the battery pack into your VAIO computer. [\[Details\]](#)
2. Plug your VAIO computer into an AC outlet. [\[Details\]](#)

Hint

- The charging time varies depending on ambient temperature.
Note that at a low ambient temperature, it takes longer time to charge the battery pack.
- To check the battery status of your VAIO computer, click the battery icon, such as  (on battery) or  (plugged in), in the desktop notification area.

Related Topic

[Charge Indicator Status List](#)[Checking the Battery Charge Capacity](#)[Extending the Battery Life](#)

[▶ Troubleshooting](#)**How to Use**[Parts Description](#)[Setup](#)[Network / Internet](#)[Connections](#)[Settings](#)[Backup / Recovery](#)[Security](#)[Other Operations](#)[Notifications](#)

Installing/Removing the Battery Pack

Install the battery pack into the battery compartment on the bottom of your VAIO computer.

To install the battery pack

1. Turn off your VAIO computer and close the LCD screen lid.
2. Slide the battery LOCK switch to the unlock position.
3. Slide the battery pack diagonally into the battery compartment until the projection (1) on each side of the battery compartment fits into the groove (2) on each side of the battery pack.

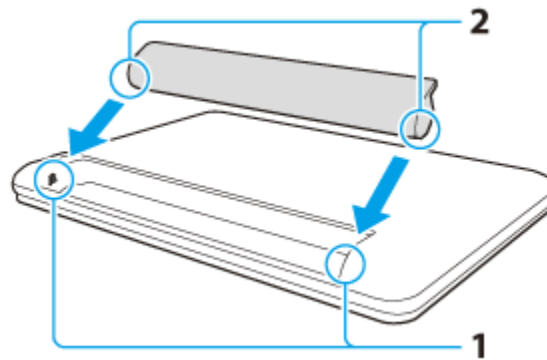

4. Turn the battery pack in the direction of the arrow and push the battery pack down into the compartment until it clicks into place.

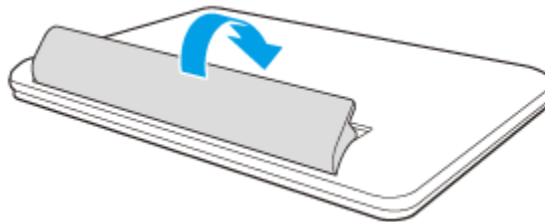

5. Slide the battery LOCK switch to the LOCK position to secure the battery pack on your VAIO computer.

To remove the battery pack

1. Turn off your VAIO computer and close the LCD screen lid.
2. Slide the battery LOCK switch to the unlock position.
3. Slide and hold the battery RELEASE latch, put your fingertip underneath the tab on the battery pack, and lift the battery pack in the direction of the arrow.

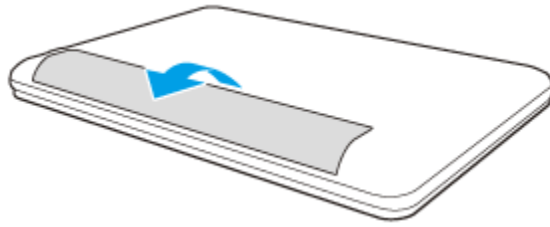

4. Slide the battery pack diagonally to take out from your VAIO computer.

Note

- You will lose all unsaved data if you remove the battery pack while your VAIO computer is on or in Sleep mode and not connected to the AC adapter.
Be sure to turn off the computer before removing the battery pack.

Related Topic

[Charging the Battery Pack](#)

[Notes on Using the Battery Pack](#)

[Shutting Down Your VAIO Computer](#)

[▶ Troubleshooting](#)

How to Use

[Parts Description](#)

[Setup](#)

[Network / Internet](#)

[Connections](#)

[Settings](#)

[Backup / Recovery](#)

[Security](#)

[Other Operations](#)

[Notifications](#)

Changing the Rapid Wake (Sleep Mode) Settings

You can change the Rapid Wake settings on VAIO Control Center.

Rapid Wake is enabled by default. With this function, you can keep your VAIO computer in Sleep mode without risk of data loss because the computer enters Sleep mode after your working data is saved on the built-in storage device.

For models that support Rapid Wake + Eco, you can conserve more battery power by reducing power consumption when the computer is in Sleep mode.

1. Click  (Start), All Programs, and VAIO Control Center.
2. Click Power Management and Rapid Wake.
Click to select or clear the check box for Rapid Wake.
Select the check box to enable Rapid Wake or clear it to disable the function.

Note

- With Rapid Wake disabled, your working data is not saved on the built-in storage device when the computer enters Sleep mode. Therefore, if the computer is turned off during Sleep mode because, for example, the battery pack runs out of power or the computer is disconnected from an AC power source, the working data will be lost and cannot be restored. To avoid data loss, be sure to save the data before the computer enters Sleep mode. With Rapid Wake disabled, the power indicator light blinks slowly in orange during Sleep mode, and the charge and power indicator lights blink simultaneously when the battery pack runs out of power during Sleep mode.
When you use the Hibernate mode, you need to disable Rapid Wake.

Related Topic

[Using Sleep Mode](#)[Notes on Sleep Mode](#)

[▶ Troubleshooting](#)

How to Use

[Parts Description](#)

[Setup](#)

[Network / Internet](#)

[Connections](#)

[Settings](#)

[Backup / Recovery](#)

[Security](#)

[Other Operations](#)

[Notifications](#)

Charge Indicator Status List

The charge indicator light  turns on or blinks differently according to conditions.

Lit in orange

The battery pack is charging. (Turns off when charging is completed.)

Blinks in orange along with the green power indicator 

The battery pack is running out of power. (Normal mode)

Blinks fast in orange

A battery error has occurred due to a failed battery pack or an unlocked battery pack.

Related Topic

[Charging the Battery Pack](#)

[Checking the Battery Charge Capacity](#)

[Extending the Battery Life](#)

[▶ Troubleshooting](#)

How to Use

[Parts Description](#)

[Setup](#)

[Network / Internet](#)

[Connections](#)

[Settings](#)

[Backup / Recovery](#)

[Security](#)

[Other Operations](#)

[Notifications](#)

Checking the Battery Charge Capacity

The battery pack is consumable. The capacity gradually declines through repeated cycles of recharging and discharging. As a result, the battery life becomes short even if it is fully charged and eventually the battery pack reaches the end of its life.

If the battery life has become short, replace the battery pack with a new one specified by Sony. Refer to the help file for more information on battery charge status and capacity decrease.

1. Click  (Start), All Programs, and VAIO Control Center.
2. Click Power Management and Battery.

Detailed battery pack information, such as charging capacity, is displayed.

Hint

- Enable the battery care function to maximize the battery lifespan. With this function, you can reduce battery degradation by limiting the maximum charging capacity.

Related Topic

[Extending the Battery Life](#)[Notes on Using the Battery Pack](#)[Charging the Battery Pack](#)

[▶ Troubleshooting](#)

How to Use

[Parts Description](#)

[Setup](#)

[Network / Internet](#)

[Connections](#)

[Settings](#)

[Backup / Recovery](#)

[Security](#)

[Other Operations](#)

[Notifications](#)

Extending the Battery Life

When your VAIO computer is running on battery power, you can extend the battery life using the following methods.

- Use Sleep mode. [\[Details\]](#)

When you do not need to use your VAIO computer temporarily, you can use Sleep mode. To extend the battery life, use Sleep mode frequently. If you do not intend to use the computer for an extended period of time, turn off the computer.

Resuming the computer from Sleep mode is faster than from booting up the computer.

- Decrease the LCD brightness of the computer screen. [\[Details\]](#)
- Turn down the volume of the speakers and headphones. [\[Details\]](#)
- Disconnect peripheral devices that are not in use.

Related Topic

[Checking the Battery Charge Capacity](#)[Charging the Battery Pack](#)[Notes on Using the Battery Pack](#)[Using Sleep Mode](#)

[▶ Troubleshooting](#)

How to Use

[Parts Description](#)

[Setup](#)

[Network / Internet](#)

[Connections](#)

[Settings](#)

[Backup / Recovery](#)

[Security](#)

[Other Operations](#)

[Notifications](#)

Notes on Using the Battery Pack

Before using the battery pack, read the following precautions for correct use.

About the battery pack

- The supplied battery pack is designed specifically for your VAIO computer.
- For your safety, only use the supplied battery pack or an optional battery pack that is specified by Sony.
- For safety reasons, battery charging may be suspended at higher or lower temperatures.
- While your VAIO computer is connected to an AC outlet with the AC adapter, it runs on AC power, even if the battery pack is installed.
- The battery pack is not fully charged at the time of delivery.
- While the battery pack is in use or being charged, heat builds up in the battery pack. This is normal and is not cause for concern.
- Do not use your VAIO computer without installing the battery pack as it may cause the computer to malfunction.

About battery discharge

After battery charge, the battery pack will gradually discharge over time even while not in use. If it is left unused for an extended period of time, the battery power may be depleted. It is recommended that you recharge the battery pack before use.

About battery life

Battery life varies depending on usage and settings.

About battery deterioration and replacement

- The battery pack is consumable. The capacity gradually declines through repeated cycles of recharging and discharging. As a result, the battery life becomes short even if it is fully charged and eventually the battery pack reaches the end of its life.
- If the battery pack quickly runs out of power after being fully charged or it has reached the end of its life, replace it with a new one.

When the battery pack is running out of power

If the battery pack runs out during your absence, power will be cut off and any data you are working on will be lost.

While your VAIO computer is running on battery power, save data frequently.

Related Topic

[Notes on Using the Power Source](#)

[▶ Troubleshooting](#)

How to Use

[Parts Description](#)[Setup](#)[Network / Internet](#)[Connections](#)[Settings](#)[Backup / Recovery](#)[Security](#)[Other Operations](#)[Notifications](#)

Connecting a Power Source

Connect your VAIO computer to an AC power source. Carefully read the precautions in [Notes on Using the Power Source](#) before connection. [\[Details\]](#)

1. Plug one end of the power cord (1) into the AC adapter (3).
2. Plug the other end of the power cord into an AC outlet (2).
3. Plug the cable from the AC adapter (3) into the DC IN port (4) on your VAIO computer.

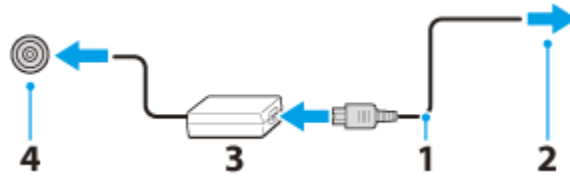

Note

- Do not plug more than one device into the same AC outlet.
- The shape of the AC adapter varies depending on the model you purchased.
- Make sure that the power plug is firmly plugged into your VAIO computer.

Hint

- You can purchase a power strip with a surge protector to help prevent damage to your VAIO computer caused by sudden power surges (in an electrical storm, for example).

Related Topic

[Installing/Removing the Battery Pack](#)[Charging the Battery Pack](#)[Notes on Using the Battery Pack](#)[Turning on Your VAIO Computer](#)[Shutting Down Your VAIO Computer](#)[Notes on Using the Power Source](#)

[▶ Troubleshooting](#)

How to Use

[Parts Description](#)

[Setup](#)

[Network / Internet](#)

[Connections](#)

[Settings](#)

[Backup / Recovery](#)

[Security](#)

[Other Operations](#)

[Notifications](#)

Shutting Down Your VAIO Computer

Shut down your VAIO computer properly to avoid losing unsaved data.

1. Turn off any peripherals connected to your VAIO computer.
2. Save your data and close all running software applications.
3. Click  (Start) and the Shut down button.

After a short time, your VAIO computer automatically turns off and the green power indicator light turns off.

Before closing the LCD screen lid, make sure the power indicator is off.

Note

- An improper shutdown may cause loss of unsaved data or your VAIO computer to malfunction.
- To disconnect your VAIO computer completely from an AC power source, turn off the computer and unplug the power cord from the AC outlet.

Related Topic

[Turning on Your VAIO Computer](#)[Restarting Your VAIO Computer](#)[Using Sleep Mode](#)[Notes on Using the Power Source](#)

[▶ Troubleshooting](#)

How to Use

[Parts Description](#)[Setup](#)[Network / Internet](#)[Connections](#)[Settings](#)[Backup / Recovery](#)[Security](#)[Other Operations](#)[Notifications](#)



Turning on Your VAIO Computer

Turn on your VAIO computer to start Windows. Carefully read the precautions in Notes on Using the Power Source before turning on. [\[Details\]](#)

1. Install the battery pack on your VAIO computer [\[Details\]](#), and then connect to an AC outlet. [\[Details\]](#)
2. Lift the LCD screen lid.
3. Press and hold down the  (Power) button until the power indicator light turns on in green.

Your VAIO computer is turned on, and Windows starts after a while.

Note

- If you press and hold down the  (Power) button for more than four seconds, your VAIO computer will not turn on. Press the  (Power) button lightly, and release it immediately when the power indicator light turns on.
- Do not use your VAIO computer without installing the battery pack as it may cause the computer to malfunction.
- When opening the LCD screen lid, do not hold the built-in camera as it may cause your VAIO computer to malfunction. (Built-in camera equipped models)
- If you press the  (Power) button with the LCD screen lid closed, your VAIO computer will not turn on.

Hint

- By default, your VAIO computer automatically enters Sleep mode after a certain period of inactivity while the computer is connected to an AC outlet. [\[Details\]](#)

Related Topic

[Installing/Removing the Battery Pack](#)[Charging the Battery Pack](#)[Notes on Using the Battery Pack](#)[Connecting a Power Source](#)[Shutting Down Your VAIO Computer](#)[Restarting Your VAIO Computer](#)[Notes on Using the Power Source](#)

[▶ Troubleshooting](#)

How to Use

[Parts Description](#)

[Setup](#)

[Network / Internet](#)

[Connections](#)

[Settings](#)

[Backup / Recovery](#)

[Security](#)

[Other Operations](#)

[Notifications](#)

Notes on Sleep Mode

Read the following precautions before using Sleep mode.

- Some software applications may not support Sleep mode. When running such applications, exit them before placing your VAIO computer into Sleep mode.
- Some USB devices may not support Sleep mode. When your VAIO computer resumes from Sleep mode, the computer may not recognize such USB devices, depending on the type and number of connected USB devices.
If you cannot place the computer into Sleep mode, disconnect all USB devices before placing the computer into Sleep mode.
- If your VAIO computer enters Sleep mode when Windows or the computer is unstable, it may not resume from Sleep mode. The following operations are recommended:
 - Before placing your VAIO computer into Sleep mode, save your files and close running software.
 - Shut down your VAIO computer periodically.
- Depending on the condition of Windows, your VAIO computer cannot enter Sleep mode.
- If your VAIO computer enters Sleep mode while running a task, such as DVD writing, the task may be suspended.

Related Topic

[Using Sleep Mode](#)[Notes on Using the Power Source](#)[Notes on Using the Battery Pack](#)

[▶ Troubleshooting](#)

How to Use

[Parts Description](#)

[Setup](#)

[Network / Internet](#)

[Connections](#)

[Settings](#)

[Backup / Recovery](#)

[Security](#)

[Other Operations](#)

[Notifications](#)

Notes on Using the Power Source

Read the following precautions before plugging your VAIO computer into an AC power source.

- If you remove the battery pack while your VAIO computer is turned on or in Sleep mode but it is disconnected from an AC power source, you may lose all unsaved data.
- If you leave your VAIO computer without connecting it to an AC power source for an extended period of time, turn off the computer.

Notes on the AC adapter

- Use the AC adapter supplied with your VAIO computer or genuine Sony products. Do not use any other AC adapter as it may cause a malfunction.
- Do not connect the AC adapter to a power conversion device such as a travel power converter. It may cause overheating or a malfunction.
- If the AC adapter cable becomes damaged or broken, do not use it.

Notes on turning on your VAIO computer

- Because your VAIO computer contains magnetic components, keep magnetic storage media, such as floppy disks, away from the computer, as it may cause data corruption.
- Your VAIO computer will automatically enter Sleep mode (with the default settings) when you move magnetic devices closer to the computer. Keep magnetic devices away from the computer.

Related Topic

[Connecting a Power Source](#)[Turning on Your VAIO Computer](#)[Shutting Down Your VAIO Computer](#)[Restarting Your VAIO Computer](#)

[▶ Troubleshooting](#)

How to Use

[Parts Description](#)

[Setup](#)

[Network / Internet](#)

[Connections](#)

[Settings](#)

[Backup / Recovery](#)



[Security](#)

[Other Operations](#)

[Notifications](#)

Restarting Your VAIO Computer

After changing the settings or installing software on your VAIO computer, you may be required to restart the computer.

1. Save your data and close all running software applications.
2. Click  (Start),  (arrow) next to the Shut down button, and Restart.
Your VAIO computer will restart.

Related Topic

[Turning on Your VAIO Computer](#)[Shutting Down Your VAIO Computer](#)

[▶ Troubleshooting](#)

How to Use

[Parts Description](#)

[Setup](#)

[Network / Internet](#)

[Connections](#)

[Settings](#)

[Backup / Recovery](#)

[Security](#)

[Other Operations](#)

[Notifications](#)

Selecting a Power Plan

Power management helps you set up power plans to suit your requirements for power consumption.

1. Click  (Start), Control Panel, Hardware and Sound, and Power Options.
2. Select your desired power plan.
3. If you want to change the power plan settings, click Change plan settings on the right of your desired power plan in the Power Options window.
By clicking Change advanced power settings, you can change the advanced settings.
Refer to Windows Help and Support for more information on the power plan settings.

Hint

- The power status icon indicates what kind of power source your VAIO computer is currently using, and you can see the computer's power status by clicking this icon.
-

[▶ Troubleshooting](#)

How to Use

[Parts Description](#)[Setup](#)[Network / Internet](#)[Connections](#)[Settings](#)[Backup / Recovery](#)[Security](#)[Other Operations](#)[Notifications](#)

Using Sleep Mode

In Sleep mode, all unnecessary devices of your VAIO computer are turned off, though some devices stay on to retain the computer's state including data you are working on. Sleep mode is useful when you take a short rest, for example.

With the default Sleep mode settings, Rapid Wake is enabled and the computer's state is saved to the built-in storage device.

To activate Sleep mode

1. Click (Start), (arrow) next to the Shut down button, and Sleep.
The power indicator light turns off when your VAIO computer enters Sleep mode.

Hint

- By default, your VAIO computer enters Sleep mode automatically after about 30 minutes of inactivity while running on AC power.
- The operations below also place your VAIO computer into Sleep mode.
 - Press the (Power) button (with the default setting).
Note that if you press and hold down the (Power) button for more than four seconds, your VAIO computer will turn off automatically. Doing this will erase all unsaved data.
 - Close the LCD screen lid and leave the computer unused for a few seconds.

To return to Normal mode

1. Press the (Power) button.

Note

- Your VAIO computer does not return to Normal mode with keyboard and touch pad operations.
- By default, your VAIO computer automatically enters Hibernate mode when the battery pack becomes weak. However, depending on the currently running software and connected devices, Windows may not allow their tasks to be suspended, resulting in failure to enter Hibernate mode. If this occurs and the battery pack is running out of power, the computer will be turned off, resulting in loss of unsaved data.
While the computer is running on battery power, save data frequently.
- Before moving your VAIO computer, make sure that the power indicator light is off to avoid impact or vibration to the running hard disk drive.

Hint

- If you press and hold down the (Power) button for more than four seconds, your VAIO computer will turn off automatically. Doing this will erase all unsaved data.
- You can restore your VAIO computer from Sleep mode to Normal mode by opening the LCD screen lid. To change the action when you open the lid, change the settings in Lid Action Settings under Power Management on VAIO Control Center.

Related Topic

[Notes on Using the Power Source](#)

[▶ Troubleshooting](#)

How to Use

[Parts Description](#)

[Setup](#)

[Network / Internet](#)

[Connections](#)

[Settings](#)

[Backup / Recovery](#)

[Security](#)

[Other Operations](#)

[Notifications](#)

About a Security Key for a Wireless LAN

A security key is a security protocol for a wireless LAN that encrypts data transmitted on the wireless LAN. It is also referred to as an encryption key or a WEP (Wired Equivalent Privacy) key.

The security key allows wireless devices that have the same key, such as a wireless LAN access point and a computer, to communicate with each other on the wireless LAN.

The security key is assigned to each access point by default. (Make sure the default security key has been changed to protect data from unauthorized use.) If you cannot find the default security key, refer to the manual that came with your access point.

If you enter a wrong security key, follow these steps to re-enter the security key.

1. Click  (Start) and Control Panel.
2. Click Network and Internet and Network and Sharing Center.
3. Click Manage wireless networks in the left pane.
4. Right-click the desired network in the Networks you can view and modify list, and then click Properties.
5. Click the Security tab.
6. Enter a security key in the Network security key field and click OK.

Related Topic

[About the Wireless LAN Standards](#)[Before Using the Wireless LAN](#)[Starting Wireless LAN Communications](#)[Notes on Using the Wireless LAN Function](#)

[▶ Troubleshooting](#)

How to Use

[Parts Description](#)

[Setup](#)

[Network / Internet](#)

[Connections](#)

[Settings](#)

[Backup / Recovery](#)

[Security](#)

[Other Operations](#)

[Notifications](#)

About the Internet Connection Services

The following types of Internet connection services are available. You can select from among the services according to your preference, for example, communication speed or a usage fee. For detailed information on a variety of connection services, contact Internet Service Providers (ISPs).

- Fiber to the Home (FTTH)
- Cable modem
- Digital Subscriber Line (DSL)
- Satellite
- Dial-up

Related Topic

[Connecting to the Internet with a Wired Connection](#)[Starting Wireless LAN Communications](#)

[▶ Troubleshooting](#)

How to Use

[Parts Description](#)

[Setup](#)

[Network / Internet](#)

[Connections](#)

[Settings](#)

[Backup / Recovery](#)

[Security](#)

[Other Operations](#)

[Notifications](#)

About the Network (LAN)

The network (LAN) enables you to connect your VAIO computer to the Internet and transfer data between the computer and other devices.

You can connect your VAIO computer to 1000BASE-T/100BASE-TX/10BASE-T type networks with a LAN cable (not supplied). Connect one end of a LAN cable to the LAN port on the computer and the other end to your network.

For information on peripheral devices required for LAN access, ask your Internet Service Provider (ISP) or refer to the manual that came with your modem.

For information on how to connect your VAIO computer to the network, refer to your ISP's instructions or the manual that came with the modem and other peripheral devices. If you require information on the network settings at your workplace, ask the network administrator.

Related Topic

[About the Internet Connection Services](#)[Starting Wireless LAN Communications](#)

[▶ Troubleshooting](#)

How to Use

[Parts Description](#)

[Setup](#)

[Network / Internet](#)

[Connections](#)

[Settings](#)

[Backup / Recovery](#)

[Security](#)

[Other Operations](#)

[Notifications](#)

About the Wireless LAN Standards

The Wireless Local Area Network (WLAN) allows your VAIO computer to connect to a network through a wireless connection.

The WLAN uses the following IEEE 802.11a/b/g/n standard, which specifies the type of technology used.

Refer to the specifications to find out about the configuration of the computer.

IEEE 802.11a (Frequency band:5 GHz)

Exclusive to models compliant with the IEEE 802.11a/b/g/n standard.

IEEE 802.11b/g (Frequency band:2.4 GHz)

The IEEE 802.11g standard provides higher-speed communications than the IEEE 802.11b.

IEEE 802.11n (Frequency band:2.4 GHz/5 GHz)

For models compliant with the IEEE 802.11b/g/n standard, only 2.4 GHz band can be used.

Related Topic

[Before Using the Wireless LAN](#)

[Starting Wireless LAN Communications](#)

[Stopping Wireless LAN Communications](#)

[Notes on Using the Wireless LAN Function](#)

[▶ Troubleshooting](#)

How to Use

[Parts Description](#)

[Setup](#)

[Network / Internet](#)

[Connections](#)

[Settings](#)

[Backup / Recovery](#)

[Security](#)

[Other Operations](#)

[Notifications](#)

Before Using the Wireless LAN

You first need to establish wireless LAN communications between your VAIO computer and an access point (not supplied) before connecting the computer to the Internet using the wireless LAN. Refer to Windows Help and Support and the manual that came with your access point for more information.

For a quick and easy connection to the wireless LAN

When the first time you connect your VAIO computer to the Internet using the wireless LAN at home or connect the computer to a public wireless network (hotspot), use VAIO Easy Connect that helps you establish a connection to the wireless LAN quickly and easily.

1. Click  (Start), All Programs, VAIO Easy Connect, and follow the on-screen instructions in the Easy Internet Connection Setup window.

Related Topic

[About the Wireless LAN Standards](#)[Starting Wireless LAN Communications](#)[Stopping Wireless LAN Communications](#)[Notes on Using the Wireless LAN Function](#)[About a Security Key for a Wireless LAN](#)

▶ Troubleshooting

How to Use

Parts Description

Setup

Network / Internet

Connections

Settings

Backup / Recovery

Security

Other Operations

Notifications

Connecting to the Internet with a Wired Connection

Before using the Internet, you need to sign up with an Internet Service Provider (ISP) and set up devices required for connecting your VAIO computer to the Internet. Connect one end of a LAN cable (not supplied) to the LAN port on your VAIO computer and the other end to your network.

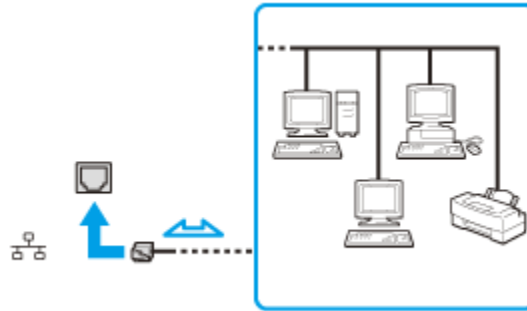

Note

- For detailed information on devices required for Internet access and how to connect your VAIO computer to the Internet, ask your ISP.
- When connecting your VAIO computer to the Internet, be sure to use a cable with network or Ethernet printed on it.
- Do not plug a telephone cable into the LAN port on your VAIO computer. If the computer is connected to the one of the networks or the LAN port is connected to the telephone lines mentioned below, high electric current to the port may cause damage, overheating, or fire.
 - Any network, except 1000BASE-T/100BASE-TX/10BASE-T type networks
 - Public telephone subscriber line
 - Private branch exchange (PBX)
 - Home (intercom speakerphone) or business-use telephone lines (multi-line business telephone)

Hint

- To connect your VAIO computer to the Internet using the wireless LAN function, you need to set up the wireless LAN network. [\[Details\]](#)

Related Topic

[About the Internet Connection Services](#)

[About the Network \(LAN\)](#)

[Starting Wireless LAN Communications](#)

[▶ Troubleshooting](#)

How to Use

[Parts Description](#)

[Setup](#)

[Network / Internet](#)

[Connections](#)

[Settings](#)

[Backup / Recovery](#)

[Security](#)

[Other Operations](#)

[Notifications](#)

Launching the Web Browser (WEB Button)

By pressing the WEB button, you can launch the default web browser.

Even when your VAIO computer is off, pressing the WEB button starts Windows, and launches the web browser.

[▶ Troubleshooting](#)**How to Use**[Parts Description](#)[Setup](#)[Network / Internet](#)[Connections](#)[Settings](#)[Backup / Recovery](#)[Security](#)[Other Operations](#)[Notifications](#)

Notes on Using the Wireless LAN Function

Before using the wireless LAN function, read the following precautions for correct use.

- In some countries or regions, using the wireless LAN products may be restricted by the local regulations.
- Wireless LAN devices work on the 2.4 GHz band, which is used by a variety of devices. Wireless LAN devices use the technology to minimize radio interference from other devices that use the same band; however, radio interference may still slow communication speeds, reduce communication range, or cause communication failure.
- If both the BLUETOOTH function and the 2.4 GHz wireless LAN function of your VAIO computer are enabled, interference may occur and cause slower communication speeds or other problems.
- To communicate via a wireless LAN while you are on the road, you may need to contract with a wireless LAN connection service provider.
- If your VAIO computer is equipped with the IEEE 802.11a/b/g/n standard, outdoor use of the 5 GHz wireless LAN function is prohibited by law.
- The communication speed and range may vary depending on the following conditions:
 - Distance between devices
 - Existence of obstacles between devices
 - Device configuration
 - Radio conditions
 - Ambient environment (including wall material, etc.)
 - Software in use

Communications may be cut off depending on radio conditions.
- The data transfer rate specified in the specification is the theoretical maximum, and may not reflect actual data transfer rate.
- Actual communication speed may not be as fast as the one displayed on your VAIO computer.
- The 2.4 GHz wireless LAN and 5 GHz wireless LAN frequency bands are not communicable with one another.
- The data transfer rate of IEEE 802.11g and IEEE 802.11n (2.4 GHz) may be affected by interference when used with an IEEE 802.11b product. Also, IEEE 802.11g and IEEE 802.11n automatically lower the transfer rate to maintain compatibility with an IEEE 802.11b product. The transfer rate may be regained by changing the channel settings of your access point.
- The IEEE 802.11a standard and the IEEE 802.11n standard are not available on ad-hoc networks.
- To stop the wireless LAN function abruptly, turn off your VAIO computer.
- The WLAN standard includes the encryption methods: Wired Equivalent Privacy (WEP), which is a security protocol, Wi-Fi Protected Access 2 (WPA2), and Wi-Fi Protected Access (WPA). Proposed jointly by the IEEE and Wi-Fi Alliance, both WPA2 and WPA are specifications of standards based on interoperable security enhancements that increase the level of data protection and access control for existing Wi-Fi networks. WPA is designed to be forward compatible with the IEEE 802.11i specification. It utilizes the enhanced data encryption Temporal Key Integrity Protocol (TKIP) in addition to user authentication using 802.1X and Extensible Authentication Protocol (EAP). Data encryption protects the vulnerable wireless link between clients and access points. Besides that, there are other typical LAN security mechanisms to ensure privacy, such

as: password protection, end-to-end encryption, virtual private networks, and authentication. WPA2, the second generation of WPA, provides stronger data protection and network access control and is also designed to secure all versions of 802.11 devices, including 802.11b, 802.11a, 802.11g, and 802.11n standards, multi-band and multi-mode. In addition, based on the ratified IEEE 802.11i standard, WPA2 provides government grade security by implementing the National Institute of Standards and Technology (NIST) FIPS 140-2 compliant AES encryption algorithm and 802.1X-based authentication. WPA2 is backward compatible with WPA.

Related Topic

[About the Wireless LAN Standards](#)

[Before Using the Wireless LAN](#)

[Starting Wireless LAN Communications](#)

[Stopping Wireless LAN Communications](#)

[Notes on Using the BLUETOOTH\(R\) Function<BLUETOOTH equipped models>](#)

[▶ Troubleshooting](#)**How to Use**[Parts Description](#)[Setup](#)[Network / Internet](#)[Connections](#)[Settings](#)[Backup / Recovery](#)[Security](#)[Other Operations](#)[Notifications](#)

Starting Wireless LAN Communications

You can establish wireless LAN communications between your VAIO computer and an access point (not supplied) using VAIO Smart Network. Before using the wireless LAN, make sure your access point is on and operating.

Read the instructions in [Before Using the Wireless LAN](#) for correct use. [\[Details\]](#)

1. Click (Start), All Programs, and VAIO Smart Network or click (the VAIO Smart Network icon) in the desktop notification area.
2. Make sure each switch next to Wireless Functions and Wireless LAN (or Wi-Fi) is toggled to On.
If it is set to Off, click it to toggle to On.

Hint

- Make sure the WIRELESS indicator light [\[Details\]](#) is on.
 - You can use the Wi-Fi Direct function if Wi-Fi Direct is displayed in the VAIO Smart Network window. Refer to the help file included with VAIO Smart Network for more information.
3. In the VAIO Smart Network window, select a mode that suits your wireless LAN. Refer to the help file included with VAIO Smart Network for more information about operations.
 4. Click or (the Network icon) in the desktop notification area.
 5. Select the desired access point and click Connect.
After the connection is established, Connected appears in the selected wireless access point field.
If you cannot find the desired access point, click (Refresh).
If a security key [\[Details\]](#) entry window appears, enter the security key as required and click OK. Note that security keys are case-sensitive.

Note

- On IEEE 802.11a/b/g/n equipped models, when only the 2.4 GHz wireless LAN function is enabled, your VAIO computer cannot connect to a 5 GHz wireless LAN access point. Also, when only the 5 GHz wireless LAN function is enabled, the computer cannot connect to a 2.4 GHz wireless LAN access point.
On IEEE 802.11b/g/n equipped models, when the 2.4 GHz wireless LAN function is disabled, the computer cannot connect to an access point. Also, the computer cannot connect to a 5 GHz wireless LAN access point.
- It may take some time to find and connect to a wireless LAN access point before starting communications via the wireless LAN.

Hint

- Once you connect your VAIO computer to the access point by entering the security key, the access point will be registered in the computer. You do not have to enter the security key for subsequent connections.

To check wireless LAN connection status

You can move the mouse pointer over or (the Network icon) in the desktop notification area to check the wireless LAN connection status, such as the access point

currently connected to your VAIO computer.

Related Topic

[About the Wireless LAN Standards](#)

[Before Using the Wireless LAN](#)

[Stopping Wireless LAN Communications](#)

[Notes on Using the Wireless LAN Function](#)

[About a Security Key for a Wireless LAN](#)

[▶ Troubleshooting](#)

How to Use

[Parts Description](#)

[Setup](#)

[Network / Internet](#)

[Connections](#)

[Settings](#)

[Backup / Recovery](#)

[Security](#)

[Other Operations](#)

[Notifications](#)

Stopping Wireless LAN Communications

Stop wireless LAN communications using VAIO Smart Network.

1. Click the switch next to Wireless LAN or Wi-Fi to toggle it to Off in the VAIO Smart Network window.

The wireless LAN function is disabled and the WIRELESS indicator light turns off.

Note

- Do not disable the wireless LAN function while accessing remote documents, files, or resources, as it may result in data loss.

Hint

- When another wireless communication function is enabled in the VAIO Smart Network window, the WIRELESS indicator light on your VAIO computer stays on.

Related Topic

[About the Wireless LAN Standards](#)[Starting Wireless LAN Communications](#)[Notes on Using the Wireless LAN Function](#)

[▶ Troubleshooting](#)

How to Use

[Parts Description](#)

[Setup](#)

[Network / Internet](#)

[Connections](#)

[Settings](#)

[Backup / Recovery](#)

[Security](#)

[Other Operations](#)

[Notifications](#)

Using the Antivirus Software for Your VAIO Computer

Protect your VAIO computer against computer viruses by using the antivirus software. You can keep the antivirus software current with the latest updates by downloading and installing the updates from the website of the software publisher. To update the antivirus software, find the antivirus software installed on your VAIO computer from the following and follow these steps.

Trend Micro:

1. Make sure your VAIO computer is connected to the Internet, click  (Start), All Programs, Trend Micro Titanium Maximum Security 2012, and Trend Micro Titanium Maximum Security 2012.
2. Follow the on-screen instructions.

McAfee:

1. Make sure your VAIO computer is connected to the Internet, click  (Start), All Programs, McAfee, and McAfee Internet Security or McAfee Total Protection.
2. Follow the on-screen instructions.

Kaspersky Internet Security:

1. Make sure your VAIO computer is connected to the Internet, click  (Start), All Programs, Kaspersky Internet Security, and Kaspersky Internet Security.
2. Follow the on-screen instructions.

Note

- The actual procedure may be different from the above depending on the version of the software installed on your VAIO computer. In such a case, follow the on-screen instructions.

Hint

- Refer to the help file included with your software for more information.

[▶ Troubleshooting](#)

How to Use

[Parts Description](#)

[Setup](#)

[Network / Internet](#)

[Connections](#)

[Settings](#)

[Backup / Recovery](#)

[Security](#)

[Other Operations](#)

[Notifications](#)

Changing the Sound Output Device

If there is no sound from the device connected to your VAIO computer, you need to change the device for sound output.

1. Click  (Start) and Control Panel.
2. Click Hardware and Sound.
3. Click Sound.
4. Click the Playback tab.
5. Ensure there is a check mark next to the icon of the device you intend to output computer sound from.
If there is no check mark next to the icon, select it and click Set Default.
6. Click OK.

To change the sound rate and bit depth

The sound rate and bit depth of the digital audio output signal should be set according to your digital audio device. Follow these steps.

1. Click  (Start) and Control Panel.
2. Click Hardware and Sound.
3. Click Sound.
4. Click the Playback tab.
5. Select the icon of your HDMI device or OPTICAL OUT (optical digital audio output) and click Properties.
6. Click the Advanced tab.
7. Select the sample rate and bit depth (for example, 16 bit, 48000 Hz (DVD quality)) which the device supports.
8. Click OK.

Related Topic

[Connecting External Speakers or Headphones](#)

[Connecting a High-Quality Digital Sound Output Device between Your VAIO Computer and a TV](#)

[▶ Troubleshooting](#)**How to Use**[Parts Description](#)[Setup](#)[Network / Internet](#)[Connections](#)[Settings](#)[Backup / Recovery](#)[Security](#)[Other Operations](#)[Notifications](#)

Connecting External Speakers or Headphones

You can connect external sound output devices (such as speakers or headphones) to your VAIO computer.

1. Connect external speakers to the headphones jack  [\[Details\]](#) with a speaker cable (not supplied).

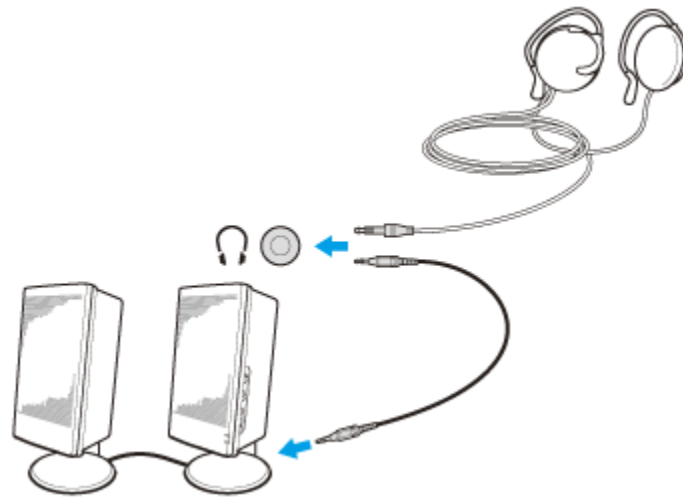
**Note**

- Turn down the volume of the speakers before turning them on.

Hint

- Refer to the manual that came with your speakers or headphones.

Related Topic[Adjusting the Speakers Volume](#)[Connecting an External Microphone](#)[Changing the Sound Output Device](#)[Adjusting the Volume in Windows](#)

[▶ Troubleshooting](#)

How to Use

[Parts Description](#)

[Setup](#)

[Network / Internet](#)

[Connections](#)

[Settings](#)

[Backup / Recovery](#)

[Security](#)

[Other Operations](#)

[Notifications](#)

Connecting a High-Quality Digital Sound Output Device between Your VAIO Computer and a TV

You can connect a high-quality home theater receiver or other surround sound decoder devices between your VAIO computer and a TV using an HDMI connection.

1. Make sure the HDMI connection has been set up between the TV and the home theater receiver or surround sound decoder device.
2. Change the device for sound output to the HDMI output. [\[Details\]](#)
3. Turn on the TV and set its input to the HDMI input.
4. Turn on the home theater receiver or surround sound decoder device and set its input to the HDMI input.
5. Plug one end of an HDMI cable to the HDMI input port on the home theater receiver or surround sound decoder device and the other end to the HDMI output port on your VAIO computer.

Hint

- You can adjust the screen resolution of the connected TV with your VAIO computer. [\[Details\]](#)
- With the HDMI connection, the volume can be adjusted by the connected audio device only. Your VAIO computer has no control over the output volume of any connected devices.

Related Topic

[Changing the Sound Output Device](#)[Changing the Resolution \(Size\) of the Screen Image](#)[Connecting a TV with an HDMI Input Port](#)

[▶ Troubleshooting](#)

How to Use

[Parts Description](#)[Setup](#)[Network / Internet](#)[Connections](#)[Settings](#)[Backup / Recovery](#)[Security](#)[Other Operations](#)[Notifications](#)

Connecting an External Microphone

You can connect an external microphone to your VAIO computer and enjoy voice chat, etc.

1. Plug the microphone cable into the microphone jack [\[Details\]](#).



Note

- If you connect or disconnect the microphone to/from your VAIO computer while running voice recording software, voice recording may fail or the software may exit. Connect the microphone and select it as the sound recording device for Windows before starting the software.

Hint

- Use a plug-in-power microphone.
- Refer to the manual that came with your microphone.
- If microphone feedback occurs, move the microphone away from your speakers.

Related Topic

[Adjusting the Microphone Volume](#)[Connecting External Speakers or Headphones](#)

[▶ Troubleshooting](#)

How to Use

[Parts Description](#)

[Setup](#)

[Network / Internet](#)

[Connections](#)

[Settings](#)

[Backup / Recovery](#)

[Security](#)

[Other Operations](#)

[Notifications](#)

Adjusting the Microphone Volume

You can adjust the volume level of the microphone.

1. Click  (Start) and Control Panel.
2. Click Hardware and Sound.
3. Click Sound.
4. Click the Recording tab.
5. Double-click the microphone icon.
6. Click the Levels tab in the Microphone Properties window.
7. Move a slider in Microphone right and left to your desired volume level.
If the microphone volume is still not loud enough even at the maximum volume level, move a slider in Microphone Boost right and left to adjust the volume level.
8. Click OK.

Related Topic

[Connecting an External Microphone](#)[Adjusting the Speakers Volume](#)[Adjusting the Volume in Windows](#)

[▶ Troubleshooting](#)

How to Use

[Parts Description](#)

[Setup](#)

[Network / Internet](#)

[Connections](#)

[Settings](#)

[Backup / Recovery](#)

[Security](#)

[Other Operations](#)

[Notifications](#)

Adjusting the Speakers Volume

You can change the volume level of the speakers and headphones.

To reduce the volume using the Fn key

1. Press the F3 key while holding down the Fn key.
The volume is turned down.

To increase the volume using the Fn key

1. Press the F4 key while holding down the Fn key.
The volume is turned up.

Hint

- You can press the Fn+F2 keys to turn off the speakers and headphones. Press the Fn+F2 keys once more to turn on the volume.
- You can also press the Fn+F4 keys to turn on the volume.

Related Topic

[Adjusting the Volume in Windows](#)

[Adjusting the Microphone Volume](#)

[Connecting External Speakers or Headphones](#)

[▶ Troubleshooting](#)

How to Use

[Parts Description](#)

[Setup](#)

[Network / Internet](#)

[Connections](#)

[Settings](#)

[Backup / Recovery](#)

[Security](#)

[Other Operations](#)

[Notifications](#)

Adjusting the Volume in Windows

You can adjust the volume on each software application from the Control Panel window.

1. Click  (Start) and Control Panel.
2. Click Hardware and Sound.
3. Click Adjust system volume under Sound.
4. Move a slider in Device up and down to your desired volume level.

When the volume is turned off () , click  (Deactivate muting) to turn on the volume (). When the volume has been minimized, turn the volume up with the slider.

To turn off the Windows startup sound

1. Click  (Start) and Control Panel.
2. Click Hardware and Sound.
3. Click Sound.
4. Click the Sounds tab.
5. Click to clear the Play Windows Startup sound check box.
6. Click OK.

Related Topic

[Adjusting the Speakers Volume](#)[Adjusting the Microphone Volume](#)[Connecting External Speakers or Headphones](#)

[▶ Troubleshooting](#)

How to Use

[Parts Description](#)

[Setup](#)

[Network / Internet](#)

[Connections](#)

[Settings](#)

[Backup / Recovery](#)

[Security](#)

[Other Operations](#)

[Notifications](#)

Changing the Resolution (Size) of the Screen Image on an HDMI-Connected Device

You can change the screen resolution or size of your VAIO computer's screen image displayed on an external display, such as a TV, connected to the computer with an HDMI cable (not supplied).

1. Connect your VAIO computer to an HDMI equipped TV with an HDMI cable. [\[Details\]](#)
2. Turn on the TV.
3. Double-click  (HDMI Resolution Settings) in the desktop notification area. The settings window appears.
4. Click the Select Resolution tab to select the desired resolution, and then click Apply. After a few seconds, the selected resolution is applied.
5. If the computer image does not fit the displayable region of the TV, click the Adjust Resolution tab to adjust the display size.

Note

- Some resolution options may not be available, depending on the model or the HDMI-connected device.
- The function to adjust the screen resolution may be disabled depending on the selected resolution.

Related Topic

[Connecting a TV with an HDMI Input Port](#)[Selecting Display Modes](#)

[▶ Troubleshooting](#)**How to Use**[Parts Description](#)[Setup](#)[Network / Internet](#)[Connections](#)[Settings](#)[Backup / Recovery](#)[Security](#)[Other Operations](#)[Notifications](#)

Connecting a TV with an HDMI Input Port

You can connect a TV with an HDMI input port to your VAIO computer with an HDMI cable (not supplied).

Refer to the manual that came with your TV for more information on installation and use.

1. Plug the power cord of your TV into an AC outlet.
2. Connect one end of an HDMI cable to the HDMI output port [\[Details\]](#) on your VAIO computer and the other end to the TV.
3. Set the TV input to the external input.

The screen image of your VAIO computer is displayed on the TV.

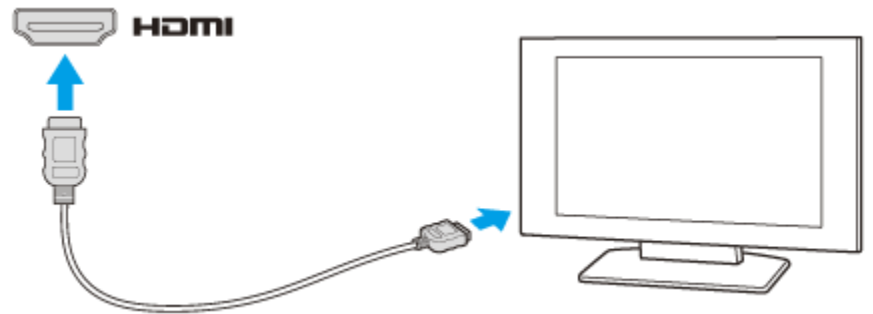
**Note**

- If a device driver other than the one provided by Sony is used, the image will not be displayed and audio will not be heard. Always use the device driver provided by Sony for updates.
- To hear sound from a device connected to the HDMI output port, you need to change the sound output device. For detailed instructions, see [Changing the Sound Output Device](#). [\[Details\]](#)
- You cannot use the HDMI output port and the monitor port on your VAIO computer at the same time.

Hint

- Your VAIO computer is compliant with the High-bandwidth Digital Content Protection (HDCP) standard and capable of encrypting the transmission channel of digital video signals for the purpose of copyright protection, which enables you to view a wide variety of copyright protected and high-quality content.

Related Topic[Selecting Display Modes](#)[Using the Multiple Monitors Function](#)[Changing the Resolution \(Size\) of the Screen Image](#)[Changing the Resolution \(Size\) of the Screen Image on an HDMI-Connected Device](#)[Connecting an External Display or Projector](#)

[▶ Troubleshooting](#)**How to Use**[Parts Description](#)[Setup](#)[Network / Internet](#)[Connections](#)[Settings](#)[Backup / Recovery](#)[Security](#)[Other Operations](#)[Notifications](#)

Connecting an External Display or Projector

You can connect an external display (such as a computer display or a projector) to your VAIO computer with a display cable (not supplied).

Refer to the manual that came with your external display or projector for more information on installation and use.

1. Plug the power cord (1) of your external display or the projector into an AC outlet and turn it on.
2. Connect the external display or the projector to the monitor port [\[Details\]](#) on your VAIO computer (2) with a display cable (3) (not supplied).
3. Press the Fn+F7 keys several times to select the external display or the projector, and then press the Enter key. [\[Details\]](#)
The screen image of the computer is displayed on the external display or the projector.
4. If necessary, connect the external display or the projector to the headphones jack on your VAIO computer (5) with a speaker cable (4) (not supplied).

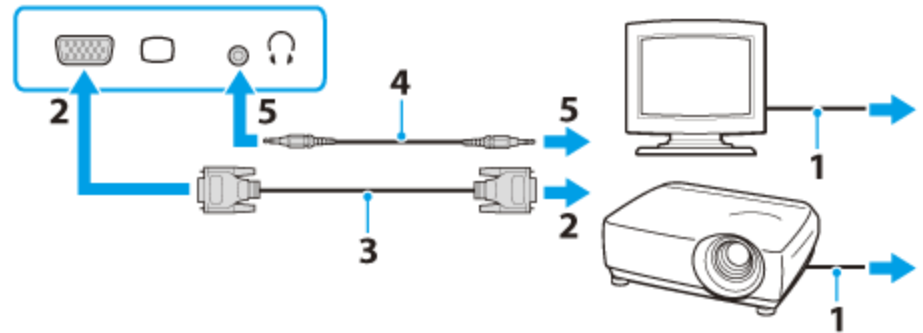
**Note**

- You cannot use the monitor port and the HDMI output port on your VAIO computer at the same time.
- Some external display and projector may not support some of the resolutions your VAIO computer can use. If your computer display does not support the selected resolution, lower the resolution setting of the computer [\[Details\]](#).

Related Topic[Selecting Display Modes](#)[Using the Multiple Monitors Function](#)[Connecting a TV with an HDMI Input Port](#)

[▶ Troubleshooting](#)

How to Use

[Parts Description](#)

[Setup](#)

[Network / Internet](#)

[Connections](#)

[Settings](#)

[Backup / Recovery](#)

[Security](#)

[Other Operations](#)

[Notifications](#)

Notes on the LCD screen

Read the following precautions for correct use of the LCD screen.

- The LCD screen is manufactured using high-precision technology. You may, however, see tiny black points and/or bright points (red, blue, or green) that continuously appear on the LCD screen. This is a normal result of the manufacturing process and does not indicate a malfunction.
- Do not scratch the surface of the LCD screen or exert pressure on it. This could cause damage.
- Do not exert pressure on the LCD screen lid with the lid closed as it may scratch the LCD screen or soil it.
- The LCD screen may become warm during operation. This is normal and does not indicate a malfunction.
- Do not leave the LCD screen facing the sun. This could damage the LCD screen. Be sure to block direct sunlight when using your VAIO computer near a window.
- Do not exert pressure on the LCD screen or its edges when opening the LCD screen lid or lifting your VAIO computer. The LCD screen may be sensitive to pressure or added stress, and exerting pressure may damage the screen or cause it to malfunction. When opening the computer, hold the base with one hand and gently lift the LCD screen lid with the other. To carry the computer with the lid open, be sure to hold the computer with both hands.
- Using your VAIO computer in low temperature conditions may produce a residual image on the LCD screen. This does not indicate a malfunction. When the computer returns to normal temperature, the screen returns to normal.
- A residual image may appear on the LCD screen if the same image is displayed for an extended period of time. The residual image disappears after a while. You can use a screen saver to prevent residual images.

[▶ Troubleshooting](#)

How to Use

[Parts Description](#)

[Setup](#)

[Network / Internet](#)

[Connections](#)

[Settings](#)

[Backup / Recovery](#)

[Security](#)

[Other Operations](#)

[Notifications](#)

Selecting Display Modes

You can switch the display output between the computer screen and an external display connected to your VAIO computer.

1. Turn on an external display.
2. Press the Fn+F7 keys several times to select your desired display output, and then press the Enter key.

Note

- If you disconnect a display cable (not supplied) while only an external display is selected as the display output, it is hard to operate your VAIO computer because the computer screen is blank.
To switch the display output to the computer screen, press the Fn+F7 keys twice, then the Enter key.
- The display switch may become unavailable or your VAIO computer may become unstable during video playback. Exit the video playback software before switching the display output.
- The display switch may not be available depending on the type of external display or projector.

Related Topic

[Using the Multiple Monitors Function](#)[Connecting a TV with an HDMI Input Port](#)[Connecting an External Display or Projector](#)

[▶ Troubleshooting](#)

How to Use

[Parts Description](#)

[Setup](#)

[Network / Internet](#)

[Connections](#)

[Settings](#)

[Backup / Recovery](#)

[Security](#)

[Other Operations](#)

[Notifications](#)

Using the Multiple Monitors Function

The Multiple Monitors function allows you to distribute portions of your desktop across separate displays.

For example, if you have an external display connected to the monitor port, the computer screen and the external display can function as a single desktop.

1. Right-click on the desktop and select Screen resolution.
2. Click the drop-down list next to Multiple Displays, select Extend these displays, and click OK.
The setting options vary depending on the number of the connected external displays.

Note

- If you set different colors on each display, do not expand a single window across two displays, or your software may not work properly.
- Your external display may not support the Multiple Monitors function.
- Certain software applications may not be compatible with the Multiple Monitors settings.
- High screen resolution and high color depth may not be displayed correctly. Set fewer colors or a lower resolution for each display.
- Do not change the display settings while using video/image software or playing DVDs, as it may cause unsuccessful playback/display or unstable system operations. Change the display settings after you exit the video/image software.

Hint

- You can set the screen resolution for each display used for the Multiple Monitors function.

Related Topic

[Changing the Resolution \(Size\) of the Screen Image](#)

[Selecting Display Modes](#)

[Connecting a TV with an HDMI Input Port](#)

[Connecting an External Display or Projector](#)

[▶ Troubleshooting](#)

How to Use

[Parts Description](#)

[Setup](#)

[Network / Internet](#)

[Connections](#)

[Settings](#)

[Backup / Recovery](#)

[Security](#)

[Other Operations](#)

[Notifications](#)

Changing the LCD Brightness

You can adjust the LCD brightness.

1. Press the Fn+F5 key or Fn+F6 keys.

To decrease lighting intensity, keep pressing the Fn+F5 keys. To increase lighting intensity, keep pressing the Fn+F6 keys.

When you press the keys, the brightness indicator is displayed for a few seconds.

Hint

- The LCD brightness setting is retained even after your VAIO computer is turned off and restarted.

Related Topic

[Combinations and Functions with the Fn Key](#)

[▶ Troubleshooting](#)

How to Use

[Parts Description](#)

[Setup](#)

[Network / Internet](#)

[Connections](#)

[Settings](#)

[Backup / Recovery](#)

[Security](#)

[Other Operations](#)

[Notifications](#)

Changing the Resolution (Size) of the Screen Image

You can change the screen resolution to adjust the size of the characters and images on the computer screen.

Refer to Windows Help and Support for more information.

1. Right-click on the desktop and select Screen resolution.
2. Click the current screen resolution next to Resolution and move the slider to change the screen resolution.

Note

- You may not be able to play high-resolution videos depending on the amount of video memory on your VAIO computer. In such a case, lower the screen resolution.
- Do not change the display resolution while using video/image software or playing DVDs, as it may cause unsuccessful playback/display or unstable system operations.

Related Topic

[Connecting an External Display or Projector](#)[Connecting a TV with an HDMI Input Port](#)[Notes on the LCD screen](#)

[▶ Troubleshooting](#)

How to Use

[Parts Description](#)

[Setup](#)

[Network / Internet](#)

[Connections](#)

[Settings](#)

[Backup / Recovery](#)

[Security](#)



[Other Operations](#)

[Notifications](#)

Charging a USB Device

You can charge a USB device even while your VAIO computer is off, in Hibernate mode, or Sleep mode by enabling the USB charging settings.

The USB charging settings are disabled by default.

1. Click  (Start), All Programs, and VAIO Control Center.
2. Click Power Management and USB Charging Settings to enable the settings.
3. Connect a USB device to the USB port with the  mark printed around it.

If charging does not start even when you connect a USB device to the USB port that supports USB charging, disconnect and connect the device.

Note

- With the USB charging settings enabled, power consumption when your VAIO computer is off or in Hibernate mode or Sleep mode increases because the computer supplies power to the USB port even when a USB device is not connected to the port.
- When the USB charging settings are enabled, you cannot use the remote wake-up function on the USB device connected to the USB port that supports USB charging.

[▶ Troubleshooting](#)**How to Use**[Parts Description](#)[Setup](#)[Network / Internet](#)[Connections](#)[Settings](#)[Backup / Recovery](#)[Security](#)[Other Operations](#)[Notifications](#)

Connecting a USB Device

You can connect a Universal Serial Bus (USB) device such as a mouse, floppy disk drive, speaker or printer to your VAIO computer. Installation of the device driver software supplied with the USB device may be required when connecting. Refer to the manual that came with the device for more information.

1. Choose the USB port (1) you prefer to use.
2. Plug the USB device cable (2) into the USB port.

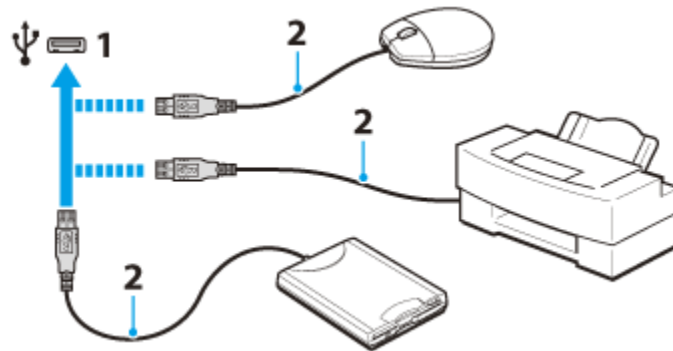
**Note**

- You may need to install the driver software supplied with your USB device before use. Refer to the manual that came with the USB device for more information.
- In order to print documents, be sure the USB printer is compatible with your version of Windows.
- Before disconnecting USB speakers from your VAIO computer, stop DVD or music playback or turn off the computer. If you disconnect the USB speakers during playback, it may cause a malfunction.
For information on how to remove a USB device, refer to the manual that came with the device.
- To protect your VAIO computer and/or USB devices from damage, observe the following:
 - When moving your VAIO computer with USB devices connected, avoid exposing the USB ports to shock or impact.
 - Do not put your VAIO computer in a bag or carrying case with USB devices connected.

Hint

- The USB ports on your VAIO computer are compliant with the USB 2.0 standard and USB 3.0 standard. USB ports that are compliant with the USB 3.0 standard are identifiable by their blue color.
- In addition to the USB 2.0 standard transfer modes, the USB 3.0 standard specifies the following transfer mode:
 - SuperSpeed: Transfer rate of 5 Gbps.

Related Topic[Connecting an External DVD Drive](#)

[▶ Troubleshooting](#)

How to Use

[Parts Description](#)

[Setup](#)

[Network / Internet](#)

[Connections](#)

[Settings](#)

[Backup / Recovery](#)

[Security](#)

[Other Operations](#)

[Notifications](#)

About BLUETOOTH(R) Security <BLUETOOTH equipped models>

The BLUETOOTH wireless technology has an authentication function, which allows you to control communication with other devices.

The authentication function helps you prevent unwanted anonymous BLUETOOTH devices from accessing your VAIO computer. The first time two BLUETOOTH devices communicate, a common passkey (a password required for authentication) should be identified to register both devices. Once a device is registered, there is no need to re-enter the passkey.

Your VAIO computer can prevent unauthorized BLUETOOTH devices from finding it and control which devices are allowed to connect with it.

For details, click  (Start) and Help and Support to open Windows Help and Support, and then enter "BLUETOOTH" in the search box.

Related Topic

[About the BLUETOOTH\(R\) Function<BLUETOOTH equipped models>](#)

[Communicating with Another BLUETOOTH\(R\) Device such as a Mouse<BLUETOOTH equipped models>](#)

[Stopping BLUETOOTH\(R\) Communications<BLUETOOTH equipped models>](#)

[Notes on Using the BLUETOOTH\(R\) Function<BLUETOOTH equipped models>](#)

[Notes on Using the Wireless LAN Function](#)

[▶ Troubleshooting](#)

How to Use

[Parts Description](#)[Setup](#)[Network / Internet](#)[Connections](#)[Settings](#)[Backup / Recovery](#)[Security](#)[Other Operations](#)[Notifications](#)

About the BLUETOOTH(R) Function <BLUETOOTH equipped models>

You can establish wireless communications between your VAIO computer and other BLUETOOTH devices, such as another computer, a smartphone, a mobile phone, a headset, or a mouse.

You can transfer data between these devices without cables at a range of up to 33 feet / 10 meters in an open area.



One BLUETOOTH device can connect with up to seven devices via wireless network to exchange data.

When a device requires connection to another device, it sends out an inquiry to neighboring BLUETOOTH devices. If any device responds to the inquiry, the two devices can connect with each other.

Related Topic

[Communicating with Another BLUETOOTH\(R\) Device such as a Mouse<BLUETOOTH equipped models>](#)

[Stopping BLUETOOTH\(R\) Communications<BLUETOOTH equipped models>](#)

[Notes on Using the BLUETOOTH\(R\) Function<BLUETOOTH equipped models>](#)

[About BLUETOOTH\(R\) Security<BLUETOOTH equipped models>](#)

[▶ Troubleshooting](#)**How to Use**[Parts Description](#)[Setup](#)[Network / Internet](#)[Connections](#)[Settings](#)[Backup / Recovery](#)[Security](#)[Other Operations](#)[Notifications](#)

Communicating with Another BLUETOOTH(R) Device such as a Mouse <BLUETOOTH equipped models>

You can connect BLUETOOTH devices to your VAIO computer.

For details on BLUETOOTH communication, see About the BLUETOOTH Function <BLUETOOTH equipped models>. [\[Details\]](#)

1. Click (Start), All Programs, and VAIO Smart Network or click (the VAIO Smart Network icon) in the desktop notification area.
2. Make sure each switch next to Wireless Functions and BLUETOOTH is toggled to On.

If it is set to Off, click it to toggle to On.

Hint

- If your VAIO computer is compliant with BLUETOOTH high speed technology and you intend to use it for high-speed communications, toggle the switch next to Wireless LAN or Wi-Fi to On, too.
 - Make sure that the WIRELESS indicator light on your VAIO computer is on.
3. Click (Start) and Devices and Printers.
 4. When connecting a BLUETOOTH mouse, turn it on and press the button to connect the mouse.

Hint

- Refer to the manual that came with your BLUETOOTH device for the procedure to have the device ready for connection.
5. Click Add a device.
Your VAIO computer searches for devices and displays a device list. Follow the on-screen instructions to register your device.

Note

- Depending on the BLUETOOTH device, it may take some time for your VAIO computer to find the device. If your device does not appear in the list, repeat the procedure to have the device ready for connection (for example, pressing the button for connection).
- Depending on the BLUETOOTH device, the procedure to establish connection may vary. Refer to the manual that came with the device for the procedure.

Hint

- To connect a BLUETOOTH mouse, select it from the device list and click the Next button. If the Select a pairing option window appears, select Pair without using a code and click the Next button. Click Close with the mouse you selected to close the window.
- For details on the operations, click (Start) and Help and Support to open Windows Help and Support, and then enter "BLUETOOTH" in the search box.
- A window appears for passkey input if a BLUETOOTH device is requesting authentication to establish connection. Follow the on-screen instructions to share the passkey between the BLUETOOTH device and your VAIO computer. If you do not wish to connect, click the Cancel button in the window.

A passkey is a secret number that is entered by a user to use for the authentication process to allow two BLUETOOTH devices to communicate with each other. Enter the

same alphanumeric string (case-sensitive) for both devices to allow them to communicate with each other. You can change the passkey every time you perform authentication, providing you enter the same passkey for both devices during the authentication process. For details on the passkey of a BLUETOOTH device, refer to the manual that came with the device. If no BLUETOOTH passkey is entered for a certain time, the connection process will be terminated for security. In this case, try again.

Related Topic

[About the BLUETOOTH\(R\) Function<BLUETOOTH equipped models>](#)

[Stopping BLUETOOTH\(R\) Communications<BLUETOOTH equipped models>](#)

[Notes on Using the BLUETOOTH\(R\) Function<BLUETOOTH equipped models>](#)

[About BLUETOOTH\(R\) Security<BLUETOOTH equipped models>](#)

[▶ Troubleshooting](#)**How to Use**[Parts Description](#)[Setup](#)[Network / Internet](#)[Connections](#)[Settings](#)[Backup / Recovery](#)[Security](#)[Other Operations](#)[Notifications](#)

Notes on Using the BLUETOOTH(R) Function <BLUETOOTH equipped models>

Before using the BLUETOOTH function, read the following precautions for correct use.

- In some countries or regions, using the BLUETOOTH function may be restricted by the local regulations.
- The BLUETOOTH function may not work with some devices, depending on the manufacturer or the software version employed by the manufacturer. Check the system requirements of the BLUETOOTH device before purchasing.
For information on BLUETOOTH devices, visit the VAIO Support website.
Some BLUETOOTH devices require authentication (pairing) before establishing connection with another device. Perform the authentication process before connecting to such devices.
- BLUETOOTH devices work on the 2.4 GHz band, which is used by a variety of devices. BLUETOOTH devices use the technology to minimize radio interference from other devices that use the same band; however, radio interference may still cause slower communication speeds, reduce communication range, or in some cases, cause communication failure.
- Communication speed and range may vary depending on the following conditions:
 - Distance between communication devices
 - Existence of obstacles between devices
 - Ambient environment that includes existence of walls and materials of such walls
 - Device configuration
 - Software in use
 - Radio conditions
 Communications may be cut off depending on radio conditions.
- If your VAIO computer is compliant with BLUETOOTH high speed technology and you intend to use it for high-speed communications, enable both the wireless LAN and BLUETOOTH functions on the computer.
- Large files may occasionally be corrupted during continuous transfer due to limitations of the BLUETOOTH standard and electromagnetic interference in the environment.
- Connecting multiple BLUETOOTH devices to your VAIO computer may cause channel congestion, resulting in poor device performance. This is normal with BLUETOOTH technology and does not indicate a malfunction.
- Video and audio may not be synchronized if you play videos on your VAIO computer with audio output from a connected BLUETOOTH device. This is a frequent occurrence with BLUETOOTH technology and does not indicate a malfunction.
- All BLUETOOTH devices must be certified through the procedure stipulated by Bluetooth SIG to ensure that they are compliant with the BLUETOOTH standard. Even if the BLUETOOTH devices are compliant with the BLUETOOTH standard, individual device performance, specifications, and operation procedures may vary. Data exchange may not be possible in all situations.
- Not all BLUETOOTH devices are guaranteed of compatibility with your VAIO computer.
- If you urgently need to disable the BLUETOOTH function, turn off your VAIO computer.

Related Topic[About the BLUETOOTH\(R\) Function<BLUETOOTH equipped models>](#)[Communicating with Another BLUETOOTH\(R\) Device such as a Mouse<BLUETOOTH](#)

[equipped models>](#)

[Stopping BLUETOOTH\(R\) Communications<BLUETOOTH equipped models>](#)

[About BLUETOOTH\(R\) Security<BLUETOOTH equipped models>](#)

[Notes on Using the Wireless LAN Function](#)

[▶ Troubleshooting](#)

How to Use

[Parts Description](#)

[Setup](#)

[Network / Internet](#)

[Connections](#)

[Settings](#)

[Backup / Recovery](#)

[Security](#)

[Other Operations](#)

[Notifications](#)

Stopping BLUETOOTH(R) Communications <BLUETOOTH equipped models>

Stop BLUETOOTH communications using VAIO Smart Network.

1. Turn off the BLUETOOTH device that is communicating with your VAIO computer.
2. In the VAIO Smart Network window, click the switch next to BLUETOOTH to toggle it to Off.

Hint

- When another wireless communication function is enabled in the VAIO Smart Network window, the WIRELESS indicator light on your VAIO computer stays on.

Related Topic

[About the BLUETOOTH\(R\) Function<BLUETOOTH equipped models>](#)

[Communicating with Another BLUETOOTH\(R\) Device such as a Mouse<BLUETOOTH equipped models>](#)

[Notes on Using the BLUETOOTH\(R\) Function<BLUETOOTH equipped models>](#)

[▶ Troubleshooting](#)**How to Use**[Parts Description](#)[Setup](#)[Network / Internet](#)[Connections](#)[Settings](#)[Backup / Recovery](#)[Security](#)[Other Operations](#)[Notifications](#)

Connecting an External DVD Drive

Connect an external DVD drive or hard disk drive to a USB port on your VAIO computer.

1. Plug the power cord of your external drive into an AC outlet (1).
2. Plug one end of a USB cable (3) (not supplied) into the USB port (2), and the other end to the external drive. [\[Details\]](#)

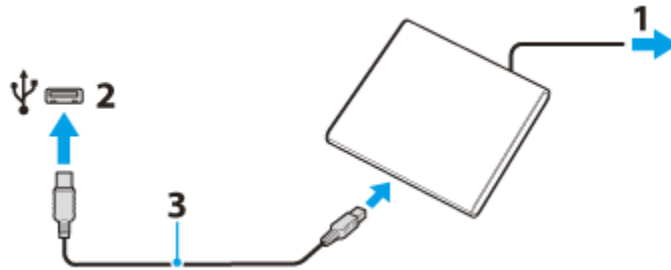
**Note**

- Be sure to connect an external drive to a power source with an AC adapter (if supplied).

Hint

- You may need to install a software driver depending on the external drive you use. In addition, procedures to connect and use an external drive vary depending on the drive you use. Refer to the manual that came with your external drive for more information.

Related Topic[Connecting a USB Device](#)

[▶ Troubleshooting](#)

How to Use

[Parts Description](#)

[Setup](#)

[Network / Internet](#)

[Connections](#)

[Settings](#)

[Backup / Recovery](#)

[Security](#)

[Other Operations](#)

[Notifications](#)

Changing the Button Assignment (VAIO Button)

You can change the current task assigned to the VAIO button. [\[Details\]](#)

To change the button assignment, you need to log onto your VAIO computer as a user with administrative rights, such as a computer administrator.

1. Press and hold down the VAIO button.
The settings window appears.
 2. Change the current task to your desired one.
You can select a task from the list.
 3. Click OK.
-

[▶ Troubleshooting](#)**How to Use**[Parts Description](#)[Setup](#)[Network / Internet](#)[Connections](#)[Settings](#)[Backup / Recovery](#)[Security](#)[Other Operations](#)[Notifications](#)

Combinations and Functions with the Fn Key

Press and hold down the Fn key and another key simultaneously to perform a keyboard shortcut action.

For example, to turn off the sound: Fn+F2 → Press and hold down the Fn key, then press the F2 key.

Some keyboard functions can only be used while Windows is running.

Fn +  (F1)

Disables and enables the touch pad. [\[Details\]](#)

Fn +  (F2)



Turns on and off the built-in speakers or the headphones.

Fn +  /  (F3/F4)

Press the button repeatedly to adjust the volume level of the built-in speakers and the headphones. [\[Details\]](#)

To decrease the volume, press the Fn+F3 keys.

To increase the volume, press the Fn+F4 keys.

Fn +  /  (F5/F6)

Press the button repeatedly to adjust the LCD brightness of your computer screen. [\[Details\]](#)

To decrease lighting intensity, press the Fn+F5 keys.

To increase lighting intensity, press the Fn+F6 keys.

Fn +  (F7)

Switches the display output to an external display.

Press the Fn+F7 keys several times to select the desired display output destination, and then press the Enter key to confirm. [\[Details\]](#)

Fn +  (F12)

Cuts off power to most of your VAIO computer, including LCD and CPU (Hibernate mode).

[▶ Troubleshooting](#)**How to Use**

[Parts Description](#)

[Setup](#)

[Network / Internet](#)

[Connections](#)

[Settings](#)

[Backup / Recovery](#)

[Security](#)

[Other Operations](#)

[Notifications](#)

Creating/Changing/Removing Your Windows Password

Setting the Windows password allows you to protect your VAIO computer from unauthorized access by making the user enter the password when the computer is turned on or returns from power saving mode to Normal mode.

Refer to Windows Help and Support for more information on the Windows password.

1. Click  (Start) and Control Panel.
2. Click User Accounts and Family Safety or User Accounts.
3. Click User Accounts.
4. Click Create a password for your account, Change your password, or Remove your password.
5. Follow the on-screen instructions to enter your password, and then press the Enter key.

Note

- Do not forget your password. Write down the password and keep it in a secure place.

Hint

- You can enter a hint in order to recall your password if you forget it. You can also create a password reset disc that can be used to create a new password. Refer to Windows Help and Support for more information on the Windows password.

Related Topic[Setting/Changing the Power-on Password](#)

[▶ Troubleshooting](#)

How to Use

[Parts Description](#)

[Setup](#)

[Network / Internet](#)

[Connections](#)

[Settings](#)

[Backup / Recovery](#)

[Security](#)

[Other Operations](#)

[Notifications](#)

Removing the Power-on Password

If power-on password input for booting up your VAIO computer is no longer necessary, follow these steps to remove the machine password and user password.

1. Turn on your VAIO computer and press the F2 key repeatedly until the VAIO logo disappears.
Enter a password if it has already been set.
The BIOS setup screen appears. If the screen does not appear, restart the computer and try again.
2. Press the **←** or **→** key to select the Security tab, select Set Machine Password or Set User Password, and then press the Enter key.
The password entry screen appears.
3. Leave the Enter New Password and Confirm New Password fields blank and press the Enter key.
4. Press the **←** or **→** key to select the Exit tab, select Exit Setup, and then press the Enter key.
At the confirmation prompt, press the Enter key.

Related Topic

[Setting/Changing the Power-on Password](#)[What should I do if I forget the power-on password to start my VAIO computer?](#)

[▶ Troubleshooting](#)**How to Use**[Parts Description](#)[Setup](#)[Network / Internet](#)[Connections](#)[Settings](#)[Backup / Recovery](#)[Security](#)[Other Operations](#)[Notifications](#)

Setting/Changing the Power-on Password

You can set a password (power-on password) for booting up your VAIO computer, using the BIOS function. Entry of the power-on password will be prompted after the VAIO logo appears to start the computer.

There are two types of passwords. Set the machine password first.

- **Machine password (for administrators):**
Allows users with administrative rights to change all the setup options in the BIOS setup screen, as well as to start your VAIO computer.
- **User password (for users without administrative rights):**
Allows standard users to change some of the BIOS setup options, as well as to start your VAIO computer. To set the user password, you must first set the machine password.

1. Turn on your VAIO computer and press the F2 key repeatedly until the VAIO logo disappears.
Enter a password if it has already been set. If you intend to change the current password, enter the password which you want to change. (For example, enter your machine password to change a machine password.)
The BIOS setup screen appears. If the screen does not appear, restart the computer and try again.
2. Press the **←** or **→** key to select the Security tab, select Set Machine Password or Set User Password, and then press the Enter key.
The password entry screen appears.
3. Enter the password and press the Enter key.
To change the password, enter the current password and a new password. The password can be set up to 32 alphanumeric characters long (including spaces) and it is case-sensitive.
4. Press the **↑** or **↓** key to select Password when Power On, press the Enter key, and select Enabled.
5. Press the **←** or **→** key to select the Exit tab, select Exit Setup, and then press the Enter key.
6. At the confirmation prompt, press the Enter key.

Note

- Be sure to write down the password to avoid forgetting it.
- If you forget the password, you cannot boot up your VAIO computer.
- You can reset the user password at the BIOS setup screen by entering the machine password.
- If you forget the machine password, the password must be reset by authorized Sony service/support center. (The reset fee will be charged.)

Related Topic[Removing the Power-on Password](#)[Creating/Changing/Removing Your Windows Password](#)[What should I do if I forget the power-on password to start my VAIO computer?](#)

[▶ Troubleshooting](#)

How to Use

[Parts Description](#)

[Setup](#)

[Network / Internet](#)

[Connections](#)

[Settings](#)

[Backup / Recovery](#)

[Security](#)

[Other Operations](#)

[Notifications](#)

Solving Common Problems with Your VAIO Computer

If you have any problem operating your VAIO computer, try these suggestions before contacting an authorized Sony service/support center or your local Sony dealer directly.

1. See other sections in this on-screen manual.
2. Start VAIO Care and perform necessary operations.
3. Visit the VAIO online support website and find necessary information.

Related Topic

[Keeping Your VAIO Computer in Optimum Condition \(VAIO Care\)](#)[Read This First](#)[About Online Support Website](#)

[▶ Troubleshooting](#)

How to Use

[Parts Description](#)

[Setup](#)

[Network / Internet](#)

[Connections](#)

[Settings](#)

[Backup / Recovery](#)

[Security](#)

[Other Operations](#)

[Notifications](#)

Disabling the Tapping Function on the Touch Pad

You can disable the tapping function to avoid unintentional movements of the pointer caused by a light touch on the touch pad.

1. Click  (Start), All Programs, and VAIO Control Center.
2. Click Keyboard and Mouse and Touchpad.
3. Click to clear the Enable tap functions check box.
4. Click OK.

Related Topic

[Using the Touch Pad](#)[Enabling/Disabling the Touch Pad](#)[Enabling/Disabling the Multi-Touch Function](#)

[▶ Troubleshooting](#)

How to Use

[Parts Description](#)

[Setup](#)

[Network / Internet](#)

[Connections](#)

[Settings](#)

[Backup / Recovery](#)

[Security](#)

[Other Operations](#)

[Notifications](#)

Enabling/Disabling the Multi-Touch Function

You can enable/disable the multi-touch function of the touch pad on your VAIO computer. With the multi-touch function, you can perform the following operations.

- Scroll
- Back/Forward
- Zoom in/Zoom out
- Rotate

1. Click  (Start), All Programs, and VAIO Control Center.
2. Click Keyboard and Mouse and Touchpad.
3. Click to select or clear the Enable multi-touch functions check box.
Select the check box to enable the function or clear it to disable the function.

Related Topic

[Using the Touch Pad](#)[Enabling/Disabling the Touch Pad](#)[Disabling the Tapping Function on the Touch Pad](#)

[▶ Troubleshooting](#)

How to Use

[Parts Description](#)

[Setup](#)

[Network / Internet](#)

[Connections](#)

[Settings](#)

[Backup / Recovery](#)

[Security](#)

[Other Operations](#)

[Notifications](#)

Enabling/Disabling the Touch Pad

You can enable/disable the touch pad on your VAIO computer.

1. Press and hold down the Fn key and press the F1 key.
Each time you press the keys, the touch pad is enabled/disabled.

Hint

- Be sure to connect a mouse before disabling the touch pad. If you disable the touch pad before connecting a mouse, you will be able to use only the keyboard for pointing operations.

Related Topic

[Using the Touch Pad](#)[Disabling the Tapping Function on the Touch Pad](#)[Enabling/Disabling the Multi-Touch Function](#)

[▶ Troubleshooting](#)**How to Use**[Parts Description](#)[Setup](#)[Network / Internet](#)[Connections](#)[Settings](#)[Backup / Recovery](#)[Security](#)[Other Operations](#)[Notifications](#)

Using the Touch Pad

By sliding your finger on the touch pad, you can move the pointer on the computer screen. With the pointer on your desired item or object, press the left button zone or the right button zone to execute various commands or display menus.

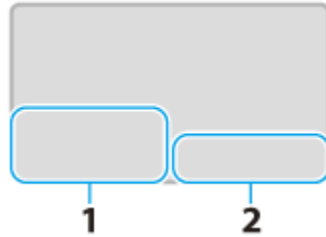

1. Left button zone
2. Right button zone

Hint

- The shape of the touch pad varies depending on the model you purchased.

To click

With the pointer on your desired item or object, press the left button zone once. Alternatively, tap on the touch pad once.

To double-click

With the pointer on your desired item or object, press the left button zone twice quickly. Alternatively, tap on the touch pad twice quickly.

To right-click

With the pointer on your desired item or object, press the right button zone once. Depending on the location of the pointer, you can display various shortcut menus.

To drag

With the pointer on your desired item or object, press the left button zone once, and while holding down the zone, slide your finger on the touch pad. Alternatively, tap on the touch pad twice quickly, and on the second tap, slide your finger.

To drag and drop

Drag an icon, such as a file, to a folder, a window, or a software icon and release your finger from the left button zone.

Alternatively, tap the icon twice quickly, and on the second tap, slide your finger to your desired location and lift the finger off the touch pad.

To scroll

Slide two fingers up and down on the touch pad to scroll vertically in the active window. Slide two fingers from side to side on the touch pad to scroll horizontally in the active window.

To back or forward without moving the pointer

On the software that supports the back/forward function, such as a web browser, put three

fingers on the touch pad and slide them from side to side to perform the back/forward operation without moving the pointer.

To zoom in or out

With some software applications, such as a photo viewer, pinch on the touch pad with two fingers for zooming. Pinch open to zoom in or pinch close to zoom out.

To rotate

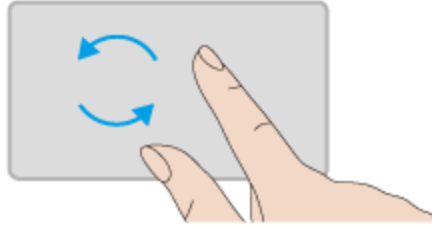

With some software applications, such as a photo viewer, slide two fingers in a circle on the touch pad to rotate an image.

Slide the fingers counterclockwise to rotate left and slide them clockwise to rotate right.

Note

- The multi-touch function (scroll, back/forward, zoom in/zoom out, rotate) may not work depending on the software you are using or the touch pad settings.

Hint

- For detailed information on how to use the touch pad, click  (Start), All Programs, and VAIO Control Center, and follow the instruction video on VAIO Control Center.

Related Topic

[Enabling/Disabling the Touch Pad](#)

[Disabling the Tapping Function on the Touch Pad](#)

[Enabling/Disabling the Multi-Touch Function](#)

[▶ Troubleshooting](#)

How to Use

[Parts Description](#)

[Setup](#)

[Network / Internet](#)

[Connections](#)

[Settings](#)

[Backup / Recovery](#)

[Security](#)

[Other Operations](#)

[Notifications](#)

Using the Built-in Camera <Built-in camera equipped models>

If your VAIO computer is equipped with a built-in camera, you can make a video call through the Internet using communication software, such as Windows Live Messenger. For detailed information on how to use the software, refer to the help file included with the software.

The built-in camera indicator light is on while the built-in camera is in use.

Hint

- The software installed on your VAIO computer varies depending on the computer's configurations.

To make a video call using Windows Live Messenger

1. Click  (Start), All Programs, and Windows Live Messenger.
You need to sign in to Windows Live Messenger to make a video call.

To display images from the built-in camera

1. Click  (Start), All Programs, ArcSoft Webcam Suite, and WebCam Companion 4.
2. Click Capture.

Hint

- If you cannot capture images properly, for example captured images are not displayed smoothly, click the current resolution of the capturing image in the upper right of the main window and lower the resolution.

Related Topic

[Notes on the Built-in Camera<Built-in camera equipped models>](#)

[▶ Troubleshooting](#)

How to Use

[Parts Description](#)

[Setup](#)

[Network / Internet](#)

[Connections](#)

[Settings](#)

[Backup / Recovery](#)

[Security](#)

[Other Operations](#)

[Notifications](#)

Notes on the Built-in Camera <Built-in camera equipped models>

- Do not scratch or soil the area on and around the built-in camera, as it may cause poor-quality images.
- Do not let direct sunlight enter the lens of the built-in camera regardless of your VAIO computer's power state, as it may cause the camera to malfunction.

Care and cleaning of the built-in camera

If the area on and around the built-in camera is soiled, gently wipe it with a soft cloth, such as a lens cleaning cloth. Do not rub the area too hard, as it can be easily scratched.

Related Topic

[Using the Built-in Camera<Built-in camera equipped models>](#)

[▶ Troubleshooting](#)

How to Use

[Parts Description](#)

[Setup](#)

[Network / Internet](#)

[Connections](#)

[Settings](#)

[Backup / Recovery](#)

[Security](#)

[Other Operations](#)

[Notifications](#)

Checking the Volume of the Recovery Area

Your built-in storage device contains the recovery area where the data for the system recovery is stored. To check the volume of the recovery area, follow these steps:

1. Click  (Start), right-click Computer, and select Manage.
 2. Click Disk Management under Storage in the left pane.
The volume of the recovery area and the total volume of the C: drive are displayed in the Disk 0 row in the center pane.
-

[▶ Troubleshooting](#)

How to Use

[Parts Description](#)

[Setup](#)

[Network / Internet](#)

[Connections](#)

[Settings](#)

[Backup / Recovery](#)

[Security](#)

[Other Operations](#)

[Notifications](#)

Creating Other Drives (Modifying Partitions)

Partitions are divided areas on your built-in storage device. Dividing the built-in storage device into more than one partition may have various advantages, such as separating the system files from your data files.

Your VAIO computer has only one partition (C: drive) as the factory default setting.*

If you want to store data in another partition, such as D: drive, change the partition size and create a new partition.

There are two ways to create partitions: using Windows and creating during recovery.

For more information on how to create partitions, refer to Windows Help and Support or see [Creating Partitions during Recovery](#). [\[Details\]](#)

* Some models may have D: drive as the factory default setting.

Related Topic

[Creating Partitions in Windows](#)[Creating Partitions during Recovery](#)[Removing Recovery Contents to Free up Disk Space](#)

[▶ Troubleshooting](#)

How to Use

[Parts Description](#)

[Setup](#)

[Network / Internet](#)

[Connections](#)

[Settings](#)

[Backup / Recovery](#)

[Security](#)

[Other Operations](#)

[Notifications](#)

Creating Partitions during Recovery

This topic describes how to create partitions.

There are two ways to create partitions: using Windows and creating during recovery. To create partitions during recovery, follow these steps:

1. Press the ASSIST button while your VAIO computer is turned off to start VAIO Care Rescue.
2. Click Tools and Start advanced recovery wizard.
Follow the on-screen instructions until a screen to select recovery type appears.
3. Click Custom recovery - Resize C: and create D: drive.
4. Enter the C: drive size and click Next.
5. Follow the on-screen instructions.

Note

- If you create partitions during recovery, all data on your built-in storage device will be erased.
- If you reduce the partition size of the C: drive, Recovery Media creation may fail due to disk space shortage.

Related Topic

[Creating Other Drives \(Modifying Partitions\)](#)[Creating Partitions in Windows](#)[Removing Recovery Contents to Free up Disk Space](#)

[▶ Troubleshooting](#)

How to Use

[Parts Description](#)

[Setup](#)

[Network / Internet](#)

[Connections](#)

[Settings](#)

[Backup / Recovery](#)

[Security](#)

[Other Operations](#)

[Notifications](#)

Creating Partitions in Windows

The Windows feature allows you to create a partition without recovering your VAIO computer system.

1. Click  (Start), Control Panel, System and Security, and Create and format hard disk partitions under Administrative Tools.
If the User Account Control window appears, click YES.

Hint

- If you are currently logged onto your VAIO computer as a standard user, you may be prompted to enter an administrator name and password.
2. Right-click the C: drive and select Shrink Volume.
 3. Enter the size of the partition to be created in Enter the amount of space to shrink in MB and click Shrink.
 4. Right-click Unallocated and select New Simple Volume.
 5. Follow the on-screen instructions.

Related Topic

[Creating Other Drives \(Modifying Partitions\)](#)[Creating Partitions during Recovery](#)[Removing Recovery Contents to Free up Disk Space](#)

[▶ Troubleshooting](#)**How to Use**[Parts Description](#)[Setup](#)[Network / Internet](#)[Connections](#)[Settings](#)[Backup / Recovery](#)[Security](#)[Other Operations](#)[Notifications](#)

Removing Recovery Contents to Free up Disk Space

Your built-in storage device contains the recovery area where the data for system recovery is stored. If your VAIO computer includes a solid state drive (SSD), you might want to minimize the recovery area by removing such data.

The above procedure involves system recovery. The applications and data you added on the storage device before removing the data for system recovery will all be lost.

Once you have removed the data for system recovery, you need the Recovery Media for later system recovery.

1. Create Recovery Media if you have not yet created it. [\[Details\]](#)
2. If you recover your VAIO computer from the Recovery Media (optical discs) on the model without a built-in optical disc drive, connect an external optical disc drive (not supplied) to the computer. [\[Details\]](#)
If an AC adapter is supplied with the external optical disc drive, plug the AC adapter into a power source.
3. Insert the disc into the optical disc drive or connect the USB flash drive (not supplied) to the USB port while your VAIO computer is in Normal mode.

Note

- If your VAIO computer is equipped with the USB port that is compliant with the USB 2.0 standard, connect a USB device to the port.
4. Turn off your VAIO computer and turn it on once again.
If you are using an external optical disc drive, restart the computer and press the F11 key repeatedly until the VAIO logo disappears.
 5. Press the or key to select VAIO Care Rescue and press the Enter key.
 6. Click Tools and Start advanced recovery wizard.
When the “Do you need to rescue data?” message appears, make a backup copy of your data, if needed.
 7. Follow the on-screen instructions until the Select recovery type window appears.
 8. Select Custom recovery - Remove recovery contents.
 9. Follow the on-screen instructions.

Related Topic[Creating Other Drives \(Modifying Partitions\)](#)[Creating Partitions in Windows](#)[Creating Partitions during Recovery](#)

[▶ Troubleshooting](#)

How to Use

[Parts Description](#)

[Setup](#)

[Network / Internet](#)

[Connections](#)

[Settings](#)

[Backup / Recovery](#)

[Security](#)

[Other Operations](#)

[Notifications](#)

About Recovery

Recovery is the process of restoring your VAIO computer back to its original factory condition.

There are two ways to recover the computer:

- From Recovery Media
- From the recovery area

When do I have to perform recovery?

- If your VAIO computer has become unstable
- If your VAIO computer has been infected with a computer virus
- If your VAIO computer is experiencing problems which cannot be solved through troubleshooting
- If you have formatted the C: drive by mistake

Which software should I use to maintain and recover my VAIO computer?

Use the following software.

VAIO Care

- Creating Recovery Media
- Checking your computer hardware

VAIO Care Rescue

- Rescuing (backing up) your data
- Recovering your VAIO computer
- Erasing all the data on your built-in storage device

Hint

- Refer to the help file included with VAIO Care and VAIO Care Rescue for more information.

What is a recovery area?

The recovery area on the built-in storage device contains data for system and application recovery. Typically, you cannot modify or delete data in this area, however, there is commercially available software designed for this purpose.

Why do I have to create Recovery Media?

Recovery Media are used to restore your VAIO computer back to its original factory condition. If Windows does not start and you have deleted the recovery area, you will need the Recovery Media to perform recovery.

Create the Recovery Media immediately after the computer is ready for use.

Related Topic

Creating Recovery Media
Recovering from the Recovery Area
Recovering from Recovery Media
Notes on Recovery

© 2012 Sony Corporation

[▶ Troubleshooting](#)**How to Use**[Parts Description](#)[Setup](#)[Network / Internet](#)[Connections](#)[Settings](#)[Backup / Recovery](#)[Security](#)[Other Operations](#)[Notifications](#)

Creating Recovery Media

Follow the instructions below to create Recovery Media.

To create Recovery Media

Hint

- You can use optical discs and a USB flash drive as Recovery Media. However, it is recommended that you use DVD-R or BD-R media, since you may accidentally delete the data on the USB flash drive.
The types of media your VAIO computer supports differ depending on the model you purchased.
- The types of media you can use for Recovery Media are DVD-R/BD-R/DVD+R/DVD+R DL/DVD-R DL/DVD+RW/DVD-RW/BD-RE/BD-R DL/BD-RE DL.
The types of media your VAIO computer supports, the number of necessary discs, and the capacity of the USB flash drive you need will be displayed during the Recovery Media creation process.

- Connect your VAIO computer to the Internet, download and install the latest updates using VAIO Update.
- If you create Recovery Media (optical discs) on the model without a built-in optical disc drive, connect an external optical disc drive (not supplied) to your VAIO computer.
[\[Details\]](#)
If an AC adapter is supplied with the external optical disc drive, plug the AC adapter into a power source.

- Click (Start), All Programs, and VAIO Care.

If the User Account Control window appears, click Yes.

Hint

- If you are currently logged onto your VAIO computer as a standard user, you may be prompted to enter an administrator name and a password.
- Click Advanced Tools, Restore and recovery, and Create Recovery Media.
 - Read the on-screen instructions carefully, and then click Next.
 - Follow the on-screen instructions.

Note

- It may take some time to display the current status of the procedure.
- Do not eject or disconnect the media while creating Recovery Media, as doing so may result in a failure of the process.
- Keep the Recovery Media in a secure place.

Notes on creating Recovery Media

- Recovery Media is specific to your VAIO computer on which it was created.
- Create Recovery Media immediately after your VAIO computer is ready for use. In the following cases, you may not be able to recover the computer from the recovery area and Recovery Media will be necessary:
 - You have modified the recovery area with software designed for data modification.

- You have installed an operating system different from the preinstalled operating system on the computer.
- You have formatted your built-in storage device without using VAIO Care Rescue.
- Do not touch or soil the surface of the discs. Fingerprints or dust on the surface may cause read/write errors.
- Depending on the model you purchased, you may not be able to create Recovery Media using optical discs except DVD-R due to disk space shortage.
- Refer to the help file included with VAIO Care beforehand when you use a USB flash drive as Recovery Media.

Related Topic

[About Recovery](#)

[Recovering from the Recovery Area](#)

[Recovering from Recovery Media](#)

[Notes on Recovery](#)

[▶ Troubleshooting](#)

How to Use

[Parts Description](#)

[Setup](#)

[Network / Internet](#)

[Connections](#)

[Settings](#)

[Backup / Recovery](#)

[Security](#)

[Other Operations](#)

[Notifications](#)

Notes on Recovery

Read the following notes thoroughly before recovering your VAIO computer.

Important notes on recovery

- Recovering your VAIO computer will delete all the data on the built-in storage device and restore all the settings to the original factory settings. Make sure you have a backup copy of your valuable data.
- Disconnect all peripherals from your VAIO computer except the power cord, the AC adapter, or devices required for recovery before recovering the computer.
- Do not stop the recovery process until the process is complete.
- If you have forgotten the password and cannot start the recovery process, contact an authorized Sony service/support center to reset it. A reset fee will be charged.

Notes on software

- Recovering your VAIO computer can restore only the preinstalled software. The software that has been installed on your own or the data you have created since purchase cannot be restored. In addition, you cannot restore only Windows.
- Certain preinstalled software includes options that allow the applications to uninstall or install themselves. However, the software may not work properly on your VAIO computer if such options are used.
- Installing software to modify partition sizes may disable recovery or Recovery Media creation.

Related Topic

[About Recovery](#)[Creating Recovery Media](#)[Recovering from the Recovery Area](#)[Recovering from Recovery Media](#)

[▶ Troubleshooting](#)**How to Use**[Parts Description](#)[Setup](#)[Network / Internet](#)[Connections](#)[Settings](#)[Backup / Recovery](#)[Security](#)[Other Operations](#)[Notifications](#)

Recovering from Recovery Media

If the recovery area data has been corrupted or erased, you can use Recovery Media to recover your VAIO computer. However, it takes longer time to recover using Recovery Media than using the recovery area.

1. If you recover your VAIO computer from Recovery Media (optical discs) on the model without a built-in optical disc drive, connect an external optical disc drive (not supplied) to the computer. [\[Details\]](#)

If an AC adapter is supplied with the external optical disc drive, plug the AC adapter into a power source.

Note

- If your VAIO computer is equipped with the USB port that is compliant with the USB 2.0 standard, connect a USB device to the port.
2. Insert the disc into the optical disc drive or connect a USB flash drive to the USB port on your VAIO computer while the computer is in Normal mode.

Note

- If your VAIO computer is equipped with the USB port that is compliant with the USB 2.0 standard, connect a USB device to the port.
3. Turn off your VAIO computer and turn it on once again.
If you are using the external optical disc drive or the USB flash drive, press the F11 key repeatedly until the VAIO logo screen disappears.
The Windows Boot Manager screen is displayed.
If the screen does not appear, restart the computer and try again.

4. Press the or key to select Start VAIO Care Rescue and press the Enter key.

Hint

- If the display language selection window appears, select your desired language and click OK.

5. Select Start recovery wizard.

6. Follow the on-screen instructions.

Hint

- To perform the custom recovery, select Tools and click Start advanced recovery wizard.
- If you cannot recover your VAIO computer using the USB flash drive, connect the drive to another USB port on the computer and try recovering the computer again.

Related Topic[About Recovery](#)[Creating Recovery Media](#)[Recovering from the Recovery Area](#)[Notes on Recovery](#)

[▶ Troubleshooting](#)

How to Use

[Parts Description](#)

[Setup](#)

[Network / Internet](#)

[Connections](#)

[Settings](#)

[Backup / Recovery](#)

[Security](#)

[Other Operations](#)

[Notifications](#)

Recovering from the Recovery Area

Recovery from the recovery area on the built-in storage device is faster than recovery using Recovery Media.

See Notes on Recovery [\[Details\]](#) before recovery.

1. Press the ASSIST button while your VAIO computer is off to start VAIO Care Rescue.

If the Edit Boot Options window is displayed, press the Enter key. VAIO Care Rescue starts.

Hint

- If the display language selection window appears, select your desired language and click OK.
2. Click Start recovery wizard.
 3. Follow the on-screen instructions.

Hint

- To perform the custom recovery, select Tools and click Start advanced recovery wizard.

Related Topic

[About Recovery](#)

[Creating Recovery Media](#)

[Recovering from Recovery Media](#)

[Notes on Recovery](#)

[▶ Troubleshooting](#)

How to Use

[Parts Description](#)

[Setup](#)

[Network / Internet](#)

[Connections](#)

[Settings](#)

[Backup / Recovery](#)

[Security](#)

[Other Operations](#)

[Notifications](#)

About Backup

The backup process creates a backup copy of your data stored on the built-in storage device and saves it to another location.

Due to unexpected events or computer viruses, you might lose various data stored on your built-in storage device. To restore the lost data, its backup copy is needed.

It is strongly recommended that you back up your data regularly.

If you can start Windows, back up and restore your data with the Windows feature.

To use the feature, click  (Start), Control Panel, System and Security, and Backup and Restore.

Related Topic

[About Types of Backup](#)[Backing Up Your Data when You cannot Start Windows](#)[Restoring Your Data with VAIO Data Restore Tool](#)[Creating a Restore Point](#)[Restoring System Files Using the Restore Point when You cannot Start Windows](#)

[▶ Troubleshooting](#)

How to Use

[Parts Description](#)[Setup](#)[Network / Internet](#)[Connections](#)[Settings](#)[Backup / Recovery](#)[Security](#)[Other Operations](#)[Notifications](#)

About Types of Backup

You can use the Windows Backup and Restore feature to back up your valuable data. There are several types of backup to meet your needs, as described below.

Backing up files

You can select and back up folders and files stored on your VAIO computer to a DVD or an external hard disk drive. For details on how to back up data, refer to Windows Help and Support.

Backing up system images

You can create a backup copy of the whole system of your VAIO computer. If the built-in storage device or the computer ever stops working, you can use the system image to restore the computer as it was when backed up.

To create a system image, you need an optional hard disk drive formatted in NTFS format. You can also back up a system image to optical discs such as Blu-ray Disc or DVD disc. For details on how to create a system image, refer to Windows Help and Support.

Restore point

After you install new software or change Windows settings, your VAIO computer may have some problems (such as slow response, unable to launch software, etc.).

You can create a restore point before such an installation or setting change to restore your system to an earlier point in time if it has a problem. For details on a restore point, see [Creating a Restore Point](#). [\[Details\]](#)

Note

- We will not restore or compensate for any lost or damaged data under any circumstances including failure of your VAIO computer.
- Create Recovery Media soon after purchasing your VAIO computer. In the event that you cannot make a backup copy of your data with the Windows feature due to computer malfunctions, you can use the backup tool included in Recovery Media to back up your data.

For information on how to create Recovery Media, see [Creating Recovery Media](#). [\[Details\]](#)

Hint

- If your VAIO computer is equipped with no disc drive, you need to connect an external device, such as an external hard disk drive or DVD drive, to the computer before backup, or you need to resize the partition of your C: drive and create another partition before backup. [\[Details\]](#)

Related Topic

[About Backup](#)[Backing Up Your Data when You cannot Start Windows](#)[Restoring Your Data with VAIO Data Restore Tool](#)[Creating a Restore Point](#)[Restoring System Files Using the Restore Point when You cannot Start Windows](#)

[▶ Troubleshooting](#)**How to Use**[Parts Description](#)[Setup](#)[Network / Internet](#)[Connections](#)[Settings](#)[Backup / Recovery](#)[Security](#)[Other Operations](#)[Notifications](#)

Backing Up Your Data when You cannot Start Windows

If you cannot start Windows, back up your data with VAIO Care Rescue.

To rescue your data

1. Press the ASSIST button while your VAIO computer is off to start VAIO Care Rescue.

Hint

- If the display language selection window appears, select your desired language and click OK.
2. Click Tools and Rescue Data.
 3. Follow the on-screen instructions.

Note

- If your VAIO computer is equipped with the USB port that is compliant with the USB 2.0 standard when you use a USB device to back up your data, connect the USB device to the port.

Hint

- Alternatively, you can start VAIO Care Rescue with Recovery Media. [\[Details\]](#)
- It is recommended that you select an external hard disk drive as a location to save rescued files if you select Custom rescue.

Notes on using Rescue Data

- Handle rescued files with care to protect from unauthorized access.
- Disable the Windows hard disk drive encryption feature before using Rescue Data to back up and restore your data.
However, rescued files which are not encrypted on the built-in storage device can be easily accessed by unauthorized users using Recovery Media and this software. Therefore, after using the software, be sure to set the power-on or hard disk password, enable the Windows hard disk drive encryption feature, and keep the Recovery Media in a secure place to protect rescued files from unauthorized access.
- To restore copyright protected data, such as music files organized by digital media playback software, use a backup tool specified by the software you used to import such data. Sony does not guarantee the playback compatibility of data which is not restored with the specified backup tool.
- Using Rescue Data does not guarantee to back up all the data on your built-in storage device.
Sony assumes no liabilities for any loss of your data arising out of the backup process.
- Use the power cord or the AC adapter to power your VAIO computer while using this software.
- Rescued files may be divided into two or more files and saved in a specified location or renamed, depending on the location you select. Use VAIO Data Restore Tool to restore the rescued files. [\[Details\]](#)
- If an external hard disk drive or optical disc drive does not support the USB connection,

you need to install a software driver.

Related Topic

[About Backup](#)

[About Types of Backup](#)

[Restoring Your Data with VAIO Data Restore Tool](#)

[Creating a Restore Point](#)

[Restoring System Files Using the Restore Point when You cannot Start Windows](#)

[▶ Troubleshooting](#)

How to Use

[Parts Description](#)

[Setup](#)

[Network / Internet](#)

[Connections](#)

[Settings](#)

[Backup / Recovery](#)

[Security](#)

[Other Operations](#)

[Notifications](#)

Creating a Restore Point

A restore point enables you to restore your computer system files to a previous state, depending on when the restore point was created.

Typically, restore points are created automatically, for example when you install a software driver. However, we recommend that you create a new restore point manually, using Control Panel, before installing any software or software drivers on your VAIO computer. Refer to Windows Help and Support for information on creating a restore point.

Related Topic

[About Backup](#)[About Types of Backup](#)[Backing Up Your Data when You cannot Start Windows](#)[Restoring Your Data with VAIO Data Restore Tool](#)[Restoring System Files Using the Restore Point when You cannot Start Windows](#)

[▶ Troubleshooting](#)

How to Use

[Parts Description](#)

[Setup](#)

[Network / Internet](#)

[Connections](#)

[Settings](#)

[Backup / Recovery](#)

[Security](#)

[Other Operations](#)

[Notifications](#)

Restoring System Files Using the Restore Point when You cannot Start Windows

When you cannot start Windows, follow these steps to restore computer system files. If you recover your VAIO computer from Recovery Media (optical discs) on the model without a built-in optical disc drive, connect an external optical disc drive (not supplied) to the computer. If an AC adapter is supplied with the external optical disc drive, plug the AC adapter into a power source.

1. Insert the disc into the optical disc drive or connect a USB flash drive to the USB port on your VAIO computer while the computer is in Normal mode.
2. Turn off your VAIO computer and turn it on once again.
If you are using an external optical disc drive or a USB flash drive, press the F11 key repeatedly until the VAIO logo screen disappears.
The Windows Boot Manager screen is displayed.
3. Press the **↑** or **↓** key to select Repair Windows 7 and press the Enter key.
4. Select a keyboard layout and click Next.
If the appropriate keyboard layout is not selected, you may not be able to enter the password correctly.
5. Select your operating system and click Next.
The system restore tool selection screen appears.
6. Click System Restore.
The System Restore window appears.
7. Click Next.
8. Select a restore point and click Next.
The confirmation window of the selected restore point appears.
9. Click Finish to confirm the restore point.
Restart your VAIO computer if the window prompts you to restart the computer.

Related Topic

[About Backup](#)[About Types of Backup](#)[Backing Up Your Data when You cannot Start Windows](#)[Restoring Your Data with VAIO Data Restore Tool](#)[Creating a Restore Point](#)

[▶ Troubleshooting](#)

How to Use

[Parts Description](#)

[Setup](#)

[Network / Internet](#)

[Connections](#)

[Settings](#)

[Backup / Recovery](#)

[Security](#)

[Other Operations](#)

[Notifications](#)

Restoring Your Data with VAIO Data Restore Tool

If you backed up files previously using VAIO Care Rescue, use VAIO Data Restore Tool to restore these files.

For instructions on how to use the software, refer to the help file included with the software.

1. Click  (Start), All Programs, and VAIO Data Restore Tool.

The VAIO Data Restore Tool window appears.

2. Click Next.

If the User Account Control window appears, click Yes.

Hint

- If you are currently logged onto your VAIO computer as a standard user, you may be prompted to enter an administrator name and password.
3. Follow the on-screen instructions.

Note

- To restore copyright protected data, such as music files organized by digital media playback software, use a backup tool specified by the software you used to import such data. Sony does not guarantee the playback compatibility of data which is not restored with the specified backup tool.

Hint

- If necessary, move the restored files to an original location.

Related Topic

[About Backup](#)

[About Types of Backup](#)

[Backing Up Your Data when You cannot Start Windows](#)

[Creating a Restore Point](#)

[Restoring System Files Using the Restore Point when You cannot Start Windows](#)

[▶ Troubleshooting](#)

How to Use

[Parts Description](#)

[Setup](#)

[Network / Internet](#)

[Connections](#)

[Settings](#)

[Backup / Recovery](#)

[Security](#)

[Other Operations](#)

[Notifications](#)

About “Memory Stick”

“Memory Stick” is a compact, portable, and versatile IC recording media especially designed for exchanging and sharing digital data with compatible products, such as digital cameras and other devices. Because it is removable, it can be used for external data storage. For the latest information about “Memory Stick”, visit <http://www.sony.net/memorycard/>.

Related Topic

[Compatible “Memory Stick”](#)[Inserting/Removing “Memory Stick”](#)[Formatting “Memory Stick”](#)[Notes on Using “Memory Stick”](#)

[▶ Troubleshooting](#)

How to Use

[Parts Description](#)[Setup](#)[Network / Internet](#)[Connections](#)[Settings](#)[Backup / Recovery](#)[Security](#)[Other Operations](#)[Notifications](#)

Compatible “Memory Stick”

The “Memory Stick” slot on your VAIO computer can accommodate the following sizes and types of media:

- “Memory Stick Duo”
- “Memory Stick PRO Duo”
- “Memory Stick PRO-HG Duo”*
- “Memory Stick Micro”

* The “Memory Stick Duo” slot on your VAIO computer does not support 8-bit parallel data transfer (high-speed data transfer).

Note

- Your VAIO computer supports only Duo-size “Memory stick”, and does not support standard-size “Memory Stick”.
- Before using “Memory Stick Micro” (“M2”), be sure to insert it into an “M2” Duo adaptor. If you insert the media directly into the “Memory Stick Duo” slot without the adaptor, you may not be able to remove it from the slot.
- Your VAIO computer has been tested and found compatible with any Sony branded “Memory Stick” of up to 32 GB, available as of January 2012. However, “Memory Stick” compatibility is not guaranteed in all cases.
- The “Memory Stick” slot on your VAIO computer does not support the copyright protection feature of “Memory Stick”.
- If you use “Memory Stick” in a place subject to static electricity or electrical noise, stored data may be lost.
- The maximum possible size for a file on “Memory Stick PRO Duo” or “Memory Stick PRO-HG Duo” is less than 4 GB, as defined in the file system specification.

Related Topic

[About “Memory Stick”](#)[Inserting/Removing “Memory Stick”](#)[Formatting “Memory Stick”](#)[Notes on Using “Memory Stick”](#)

[▶ Troubleshooting](#)**How to Use**[Parts Description](#)[Setup](#)[Network / Internet](#)[Connections](#)[Settings](#)[Backup / Recovery](#)[Security](#)[Other Operations](#)[Notifications](#)

Formatting “Memory Stick”

“Memory Stick” is formatted in the specific FAT format by default and is ready for use. Be sure to use the device that is designed to format the media and supports “Memory Stick” when formatting the media.

If you want to reformat the media with your VAIO computer, follow these steps.

Note

- Formatting “Memory Stick” erases the entire data stored on the media. Be sure to make a backup copy of important data to avoid erasing it.
- Do not remove “Memory Stick” from the slot while formatting. This could cause a malfunction.

1. Locate the “Memory Stick” slot.

Hint

- The “Memory Stick” slot on your computer also works as an SD memory card slot.

2. Carefully slide “Memory Stick” into the slot until it clicks into place. [\[Details\]](#)

3. Click  (Start) and Computer.

4. Right-click the “Memory Stick” icon and select Format. The Format Memory Stick window appears.

5. Click Restore device defaults.

The size of the allocation unit and file system will change to default settings.

Note

- Do not select NTFS from the File system drop-down list as it may cause a malfunction.

Hint

- The formatting process will be completed more quickly if you select Quick Format in Format options.

6. Click Start.

Follow the on-screen instructions.

Note

- It may take time to format “Memory Stick” depending on the media type.

Related Topic[About “Memory Stick”](#)[Compatible “Memory Stick”](#)[Inserting/Removing “Memory Stick”](#)[Notes on Using “Memory Stick”](#)

[▶ Troubleshooting](#)

How to Use

[Parts Description](#)[Setup](#)[Network / Internet](#)[Connections](#)[Settings](#)[Backup / Recovery](#)[Security](#)[Other Operations](#)[Notifications](#)

Inserting/Removing SD Memory Cards

Your VAIO computer is equipped with an SD memory card slot. You can use this slot to transfer data among digital cameras, camcorders, music players, and other audio/video devices.

The SD memory card slot on the computer can accommodate the following memory cards:

- SD memory card
- SDHC memory card
- SDXC memory card

To insert an SD memory card

1. Locate the SD memory card slot.

Hint

- The SD slot on your computer also works as a “Memory Stick” slot.
2. Hold the SD memory card with the arrow pointing toward the slot, and carefully slide it into the slot until it clicks into place.

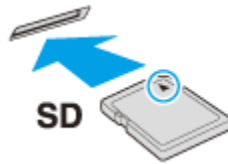

The SD memory card icon will appear in the Computer window after you insert the card into the slot.

Note

- Be careful not to insert an SD memory card with wrong orientation. If you force it into the slot upside down, the slot may be damaged. Refer to the manual that came with the SD memory card for more information.
- The SD memory card icon will not appear in the Computer window until you insert the card into the slot.

Hint

- When you insert the SD memory card into the slot for the first time, you may be prompted to install driver software. If prompted, follow the on-screen instructions to install the software.
- While data is being read from or written to the SD memory card, the media access indicator light is on.

To remove an SD memory card

1. Locate the SD memory card slot.

Hint

- The SD slot on your computer also works as a “Memory Stick” slot.
2. Check that the media access indicator light is off.
 3. Push in the SD memory card toward your VAIO computer and release.

4. Pull the SD memory card out of the slot.

Related Topic

[Notes on Using SD Memory Cards](#)

[▶ Troubleshooting](#)**How to Use**[Parts Description](#)[Setup](#)[Network / Internet](#)[Connections](#)[Settings](#)[Backup / Recovery](#)[Security](#)[Other Operations](#)[Notifications](#)

Inserting/Removing “Memory Stick”

You can use “Memory Stick” to save data or transfer images between a digital camera and your VAIO computer. To insert/remove “Memory Stick”, follow these steps.

To Insert “Memory Stick”

1. Locate the “Memory Stick” slot.

Hint

- The “Memory Stick” slot on your computer also works as an SD memory card slot.
2. Hold “Memory Stick” [\[Details\]](#) with the arrow pointing toward the slot, and carefully slide it into the slot until it clicks into place.



“Memory Stick” is automatically detected by your system and the contents of “Memory Stick” are displayed*. If nothing appears on the desktop, click (Start) and Computer, and double-click the “Memory Stick” icon*.

* The drive letter for the “Memory Stick” slot, such as “E:”, may vary depending on the system configuration of your VAIO computer.

Note

- The “Memory Stick” icon will appear in the Computer window after you insert “Memory Stick” into the slot.
- If “Memory Stick” cannot be inserted easily, remove it gently, and verify you are inserting it in the proper direction. Be sure to hold “Memory Stick” with the arrow pointing in the correct direction as you insert it into the slot. To avoid damaging your VAIO computer or the media, do not force “Memory Stick” into the slot if you cannot insert it smoothly.

Hint

- When you insert “Memory Stick” into the slot for the first time, you may be prompted to install driver software. If prompted, follow the on-screen instructions to install the software.

To remove “Memory Stick”

1. Locate the “Memory Stick” slot.

Hint

- The “Memory Stick” slot on your computer also works as an SD memory card slot.
2. Check that the Media Access indicator light is off.
 3. Push in “Memory Stick” toward your VAIO computer and release.
 4. Pull “Memory Stick” out of the slot.

Note

Do not remove “Memory Stick” while the Media Access indicator light is on. If you do, you may lose data. Large volumes of data may take time to load, so make sure the indicator light is off before removing “Memory Stick”.

- Be sure to remove “Memory Stick” gently, or it may pop out unexpectedly.

Related Topic

[About “Memory Stick”](#)

[Compatible “Memory Stick”](#)

[Formatting “Memory Stick”](#)

[Notes on Using “Memory Stick”](#)

[▶ Troubleshooting](#)**How to Use**[Parts Description](#)[Setup](#)[Network / Internet](#)[Connections](#)[Settings](#)[Backup / Recovery](#)[Security](#)[Other Operations](#)[Notifications](#)

Notes on Using SD Memory Cards

Before using SD memory cards, read the following precautions for correct use.

- Keep an SD memory card out of reach of children. There is a risk of swallowing it.
- Do not touch the SD memory card connector with your finger or metal objects.
- An SD memory card contains delicate electronic components. Do not impact, bend or drop it.
- Do not disassemble or modify an SD memory card.
- Do not wet an SD memory card.
- Do not use or store in a location subject to:
 - Extremely high temperature, such as in a car parked in the sun
 - Direct sunlight
 - High humidity or corrosive substances
 - Excessive dust
- Be sure to use SD memory cards and adaptors that are compliant with the standards supported by your VAIO computer. Incompatible cards and adaptors may get stuck in the slot, causing damage to the computer.
- You cannot write data to an SD memory card that is write-protected.
- It is recommended that you make a backup copy of important data.
- Stored data may be lost or corrupted if:
 - You remove an SD memory card or turn off your VAIO computer while the media access indicator light is on.
 - You use an SD memory card at a place where static electricity or electrical noise may disturb the card.
- When carrying an SD memory card, be sure to put it in its case to avoid static electricity.
- Before using an SD memory card with a device other than a computer, such as a digital camera or a portable audio, format (initialize) the SD memory card using the device. Some devices may not support the file format for computers and show you a message that recommends you to format the SD memory card. In this case, copy data from the card to your VAIO computer and format the card using the device. All data in the SD memory card will be deleted when you format it. Refer to the manual that came with the device for more information.
- Do not insert foreign objects into the SD memory card slot.
- The SD memory card slot can be used for reading/writing supported memory cards only, and cannot be used for other purposes.
- SD memory cards (up to 2 GB), SDHC memory cards (up to 32 GB) and SDXC memory cards (up to 64 GB) available as of January 2012 have been tested and found compatible with your VAIO computer. However, it is not guaranteed that all SD memory cards, SDHC memory cards or SDXC memory cards will be compatible with the computer.
- The SD memory card slot on your VAIO computer does not support the copyright protection feature of the SD memory card, the SDHC memory card, and the SDXC memory card.
- Do not attempt to insert a memory card or memory card adaptor of a different type into the memory card slot. An incompatible memory card or memory card adaptor may get stuck in the slot, causing damage to your VAIO computer.
- Some types of SD memory cards, for example ones with the UHS (Ultra High Speed data transfer feature), may become extremely hot due to continuous access to the memory cards. In such a case, wait for a while before removing the memory card until it

cools down.

Related Topic

[Inserting/Removing SD Memory Cards](#)

[▶ Troubleshooting](#)**How to Use**[Parts Description](#)[Setup](#)[Network / Internet](#)[Connections](#)[Settings](#)[Backup / Recovery](#)[Security](#)[Other Operations](#)[Notifications](#)

Notes on Using "Memory Stick"

Before using "Memory Stick", read the following precautions for correct use.

- Keep "Memory Stick" out of reach of children. There is a risk of swallowing it.
- Do not touch the "Memory Stick" connector with your finger or metal objects.



- "Memory Stick" contains delicate electronic components. Do not impact, bend or drop it.
- Do not disassemble or modify "Memory Stick".
- Do not wet "Memory Stick".
- Do not use or store in a location subject to:
 - Extremely high temperature, such as in a car parked in the sun
 - Direct sunlight
 - High humidity or corrosive substances
 - Excessive dust
- Be sure to use "Memory Stick" and adaptors that are compliant with the standards supported by your VAIO computer. Incompatible cards and adaptors may get stuck in the slot, causing damage to the computer.
- You cannot write data to "Memory Stick" that is write-protected.
- It is recommended that you make a backup copy of important data.
- Stored data may be lost or corrupted if:
 - You remove "Memory Stick" or turn off your VAIO computer while the media access indicator light is on.
 - You use "Memory Stick" at a place where static electricity or electrical noise may disturb the card.
- When carrying "Memory Stick", be sure to put it in its case to avoid static electricity.
- Before using "Memory Stick" with a device other than a computer, such as a digital camera or a portable audio, format (initialize) "Memory Stick" using the device. Some devices may not support the file format for computers and show you a message that recommends you to format "Memory Stick". In this case, copy data from "Memory Stick" to your VAIO computer and format "Memory Stick" using the device. All data in "Memory Stick" will be deleted when you format it. Refer to the manual that came with the device for more information.
- Do not insert foreign objects into the "Memory Stick" slot.
- The "Memory Stick" slot can be used for reading/writing supported "Memory Stick" only, and cannot be used for other purposes.

Notes on Using "Memory Stick Duo"

When using "Memory Stick Duo", do not use a fine-tipped pen to write on the label adhered to "Memory Stick Duo". Exerting pressure on the media may damage internal components.

Notes on Using "Memory Stick Micro"

Before using “Memory Stick Micro” (“M2”), be sure to insert it into an “M2” Duo adaptor. If you insert the media directly into the “Memory Stick Duo” slot without the adaptor, you may not be able to remove it from the slot.

- Keep “Memory Stick Micro” and “M2” Duo adaptors away from children. They are harmful if swallowed.

Related Topic

[About “Memory Stick”](#)

[Compatible “Memory Stick”](#)

[Inserting/Removing “Memory Stick”](#)

[Formatting “Memory Stick”](#)

[▶ Troubleshooting](#)

How to Use

[Parts Description](#)

[Setup](#)

[Network / Internet](#)

[Connections](#)

[Settings](#)

[Backup / Recovery](#)

[Security](#)

[Other Operations](#)

[Notifications](#)

Cleaning Your VAIO computer/LCD screen

Before cleaning your VAIO computer, read the following precautions for the correct cleaning procedure.

When cleaning your VAIO computer

- Turn off your VAIO computer, unplug the AC adapter, and remove the battery pack before cleaning the computer.
- Use a soft, dry cloth to wipe debris and dust off your VAIO computer.
- Be sure to use a soft, dry cloth when cleaning your VAIO computer. If the computer is badly soiled, fog the surface of the computer with your breath and wipe off the dirt, or clean off with a lightly wet cloth and then wipe remaining moisture away with a dry cloth.
- Do not use solvents such as benzine, acetone, alcohol, thinner, or commercially available cleaners, as these may cause damage to the surface or coating of your VAIO computer.
- Use an air duster for precision equipment to blow off debris and dust underneath the keys (keycaps). Do not remove any keycap from the keyboard.
Do not use a vacuum cleaner, as it may cause a malfunction.

When cleaning your LCD screen

- Be sure to use a soft, dry cloth when cleaning your VAIO computer. If the LCD screen is badly soiled, fog the surface of the LCD screen with your breath and wipe off the dirt, or clean off with a lightly wet cloth and then wipe remaining moisture away with a dry cloth.
- Do not use solvents such as benzine, acetone, alcohol, thinner, or commercially available cleaners, as these may cause damage to the LCD screen.

[▶ Troubleshooting](#)**How to Use**[Parts Description](#)[Setup](#)[Network / Internet](#)[Connections](#)[Settings](#)[Backup / Recovery](#)[Security](#)[Other Operations](#)[Notifications](#)

About the International ENERGY STAR(R) Program



The following information is applicable to ENERGY STAR qualified products only. As an ENERGY STAR Partner, Sony confirmed that this product meets the ENERGY STAR standards for energy efficiency.

The International ENERGY STAR Office Equipment Program is an international program that promotes energy saving through the use of computers and office equipment. The program backs the development and dissemination of products with functions that effectively reduce energy consumption.

For detailed information on the ENERGY STAR Program, visit the following websites:

- <http://www.energystar.gov> (USA)
- <http://www.eu-energystar.org> (Europe)

This computer is designed in compliance with the ENERGY STAR standards and delivered with the following power saving settings that apply to the computer running on AC power:

- The LCD backlight is turned off automatically after no more than 15 minutes of inactivity.
- The computer enters Sleep mode automatically after no more than 30 minutes of inactivity.

Press the  (Power) button to bring the computer back into Normal mode.

[▶ Troubleshooting](#)

How to Use

[Parts Description](#)

[Setup](#)

[Network / Internet](#)

[Connections](#)

[Settings](#)

[Backup / Recovery](#)

[Security](#)

[Other Operations](#)

[Notifications](#)

About the Software License

This product contains software owned by Sony and licensed by third parties. Use of such software is subject to the terms and conditions of license agreements enclosed with this product.

Related Topic

[Read This First](#)

[▶ Troubleshooting](#)

How to Use

[Parts Description](#)

[Setup](#)

[Network / Internet](#)

[Connections](#)

[Settings](#)

[Backup / Recovery](#)

[Security](#)

[Other Operations](#)

[Notifications](#)

Handling the Built-in Storage Device

The built-in storage device (hard disk drive or solid state drive) has a high storage density and reads or writes data in a short time. However, it can be easily damaged if improperly used.

If the built-in storage device is damaged, the data cannot be restored. To prevent losing data, you should be careful when handling your VAIO computer.

To avoid damaging your built-in storage device

- Do not subject your VAIO computer to sudden movements.
 - Keep your VAIO computer away from magnets.
 - Do not place your VAIO computer in a location subject to mechanical vibration or in an unstable position.
 - Do not turn off the power or restart your VAIO computer while reading or writing data to the storage device.
 - Do not use your VAIO computer in a place subject to extreme changes in temperature.
 - Do not remove the storage device from your VAIO computer.
-

[▶ Troubleshooting](#)

How to Use

[Parts Description](#)

[Setup](#)

[Network / Internet](#)

[Connections](#)

[Settings](#)

[Backup / Recovery](#)

[Security](#)

[Other Operations](#)

[Notifications](#)

Safety Information

Refer to the supplied safety manual for detailed safety information.

Computer

- If you drop a solid object or any liquid onto your VAIO computer, shut down the computer, unplug it, and remove the battery pack if it is removable. You may want to have the computer checked by qualified personnel before operating it again.
- Use only specified peripheral equipment and interface cables.
- Keep small parts such as “Memory Stick” and “Memory Stick” adaptors out of reach of children. There is a risk of swallowing them.
- The temperature of the surface and the bottom of your VAIO computer, the AC adapter, and the battery may rise due to the CPU load or an electric current generated while the battery is being charged. This is normal and does not indicate a malfunction. The amount of heat generation varies depending on external devices or software in use.
- If your VAIO computer or the AC adapter becomes extraordinarily hot, turn off the computer, unplug the AC adapter, remove the battery pack if it is removable, and then contact an authorized Sony service/support center.



Power source

- Do not place heavy objects on the power cord, or this could cause a fire.
- To disconnect the power cord, pull it out by holding the plug. Never pull the cord itself.
- Do not use cut or damaged connection cables.
- Unplug your VAIO computer from the AC outlet if you are not planning to use the computer for an extended period of time.
- If you are not using your VAIO computer for an extended period of time, remove the battery pack from the computer to prevent damage to the battery pack.

Headphones

- Do not use headphones while driving, cycling, or operating any motorized vehicle. It may create a traffic hazard and is illegal in some areas. It can also be potentially dangerous to play loud music while walking, especially at pedestrian crossings.
- Avoid using headphones at high volume. Hearing experts advise against continuous, loud and extended play. If you experience a ringing in your ears, reduce the volume or discontinue use.

[▶ Troubleshooting](#)**How to Use**[Parts Description](#)[Setup](#)[Network / Internet](#)[Connections](#)[Settings](#)[Backup / Recovery](#)[Security](#)[Other Operations](#)[Notifications](#)**Trademarks**

- © 2012 Sony Electronics Inc. All rights reserved. Reproduction in whole or in part without written permission is prohibited.
- Sony and the Sony logo are trademarks or registered trademarks of Sony Corporation.
- VAIO, the VAIO logo and other Sony product or service names are trademarks or registered trademarks of Sony Corporation or any of its affiliates.
- i.LINK is a name to denote IEEE 1394.
- Intel, Intel Inside, Intel Core, Pentium, Intel SpeedStep, and Atom are trademarks or registered trademarks of Intel Corporation in the United States and/or other countries.
- Microsoft, Windows, Windows Vista, BitLocker, Aero, and the Windows logo are either registered trademarks or trademarks of Microsoft Corporation in the United States and/or other countries.
- Blu-ray Disc™, Blu-ray™, Blu-ray 3D™, the Blu-ray Disc logo, and the Blu-ray 3D logo are trademarks of the Blu-ray Disc Association.
- The BLUETOOTH word mark and logos are registered trademarks owned by Bluetooth SIG, Inc. and any use of such marks by Sony Corporation is under license. Other trademarks and trade names are those of their respective owners.
- Roxio Easy Media Creator is a trademark of Sonic Solutions.
- PowerDVD is trademark of CyberLink.Inc.
- NVIDIA and 3D Vision are registered trademarks and/or trademarks of NVIDIA Corporation in the United States and other countries.
- ArcSoft and the ArcSoft logo are registered trademarks of ArcSoft, Inc. ArcSoft WebCam Companion is a trademark of ArcSoft, Inc.
- AMD, the AMD Arrow logo, ATI, and combinations thereof, Radeon, AMD Phenom, AMD Turion, AMD Athlon, AMD Virtualization, AMD-V are trademarks of Advanced Micro Devices, Inc.
- SD Logo is a trademark. 
- SDHC Logo is a trademark. 
- SDXC Logo is a trademark. 
- The ExpressCard word mark and logos are owned by the PCMCIA and any use of such marks by Sony Corporation is under license. Other trademarks and trade names are those of their respective owners.
- HDMI, the HDMI logo and High-Definition Multimedia Interface are trademarks or registered trademarks of HDMI Licensing LLC.
- CompactFlash® is a trademark of SanDisk Corporation.
- “PlaceEngine” is a registered trademark of Koozyt, Inc. “PlaceEngine” was developed by Sony Computer Science Laboratories, Inc. and is licensed by Koozyt, Inc.
- “AVCHD” is a trademark of Panasonic Corporation and Sony Corporation.
- Manufactured under license from Dolby Laboratories. Dolby and the double-D symbol are trademarks of Dolby Laboratories.
- ENERGY STAR and the ENERGY STAR mark are registered U.S. marks.

All other names of systems, products, and services are trademarks of their respective owners. In the manual, the ™ or ® marks are not specified.

Features and specifications are subject to change without notice.

All other trademarks are trademarks of their respective owners.

Not all the software listed above may be delivered with your model.

© 2012 Sony Corporation

[▶ How to Use](#)**Troubleshooting**[Hardware](#)[Software](#)[Network / Internet](#)[Backup / Recovery](#)[Security](#)[Peripheral Devices](#)**Audio**

[What should I do if I do not hear sound from a digital audio device connected to the digital output port, such as the HDMI output port?](#)

[What should I do if I do not hear sound from speakers or headphones?](#)

[What should I do if I hear microphone feedback from speakers when using my microphone?](#)

[What should I do if my microphone does not work?](#)

[What should I do if sound interruptions occur during video or audio playback?](#)

[▶ How to Use](#)**Troubleshooting**[Hardware](#)[Software](#)[Network / Internet](#)[Backup / Recovery](#)[Security](#)[Peripheral Devices](#)**BLUETOOTH**

[What should I do if I cannot find the BLUETOOTH\(R\) device I want to communicate with?](#)

[What should I do if I cannot use the BLUETOOTH\(R\) function?](#)

[What should I do if other BLUETOOTH\(R\) devices cannot connect to my VAIO computer?](#)

[What should I do if the BLUETOOTH\(R\) icon is not displayed in the desktop notification area?](#)

[Why can't I exchange business card data with a smartphone or a mobile phone?](#)

[Why can't I use BLUETOOTH\(R\) devices when I switch users?](#)

[Why can't I use the BLUETOOTH\(R\) function when I log onto my VAIO computer as a user with a standard user account?](#)

[Why is my BLUETOOTH\(R\) connection slow?](#)

[▶ How to Use](#)**Troubleshooting**[Hardware](#)[Software](#)[Network / Internet](#)[Backup / Recovery](#)[Security](#)[Peripheral Devices](#)**Camera**[What should I do if captured images contain dropped frames and audio interruptions?](#)[What should I do if captured images flicker?](#)[Why are captured images poor in quality?](#)[Why does the viewfinder show no images or poor-quality images?](#)[Why is the video input from the built-in camera suspended momentarily?](#)

[▶ How to Use](#)**Troubleshooting**[Hardware](#)[Software](#)[Network / Internet](#)[Backup / Recovery](#)[Security](#)[Peripheral Devices](#)

Display

[How do I change the LCD brightness?](#)[What should I do if I cannot see proper images on the computer screen?](#)[What should I do if black bars appear along the top, bottom, and sides of the computer screen or an external display when I display images?](#)[What should I do if captured images contain dropped frames and audio interruptions?](#)[What should I do if captured images flicker?](#)[What should I do if my VAIO computer screen freezes?](#)[What should I do if my computer screen goes blank?](#)[What should I do if no image is displayed on my TV screen or external display connected to the HDMI output port?](#)[What should I do if no image is displayed on my external display or TV screen?](#)[What should I do if some items do not fit on the computer screen?](#)[What should I do if the top, bottom, and sides of images are not displayed because they are too large to fit on the computer screen or an external display?](#)[What should I do if videos are not displayed on the computer screen?](#)[What should I do if videos are not displayed smoothly?](#)[Why do sound interruptions and/or dropped frames occur when I play high-definition videos, such as those recorded with the AVCHD digital video camcorder?](#)[Why does the viewfinder show no images or poor-quality images?](#)

[▶ How to Use](#)**Troubleshooting****Hardware**

Software

Network / Internet

Backup / Recovery

Security

Peripheral Devices

HDMI

What should I do if no image is displayed on my TV screen or external display connected to the HDMI output port?

[▶ How to Use](#)**Troubleshooting**[Hardware](#)[Software](#)[Network / Internet](#)[Backup / Recovery](#)[Security](#)[Peripheral Devices](#)**LAN**

[How can I find the physical address \(MAC address\) of the built-in wireless network interface of my VAIO computer?](#)

[What should I do if I cannot connect my VAIO computer to an access point \(or the Internet\)?](#)

[What should I do if I cannot find \(the VAIO Smart Network icon\) in the desktop notification area?](#)

[What should I do if I cannot play back movies or audio tracks received via wireless LAN, or their playback is interrupted? Why is the data transfer speed slow?](#)

[What should I do if I cannot use the wireless LAN function?](#)

[What should I do if I do not know the SSID or security key for the access point?](#)

[What should I do if the text size on the website is small or large?](#)

[What should I do if the website is not displayed?](#)

[▶ How to Use](#)**Troubleshooting****Hardware**

Software

Network / Internet

Backup / Recovery

Security

Peripheral Devices

Microphone

[What should I do if I hear microphone feedback from speakers when using my microphone?](#)

[What should I do if my microphone does not work?](#)

[▶ How to Use](#)**Troubleshooting**

Hardware

Software

Network / Internet

Backup / Recovery

Security

Peripheral Devices

Power

[What should I do if I cannot turn off my VAIO computer?](#)

[What should I do if VAIO Care Rescue starts when I turn on my VAIO computer?](#)

[What should I do if my VAIO computer does not enter Hibernate mode?](#)

[What should I do if my VAIO computer does not enter Sleep mode?](#)

[What should I do if my VAIO computer does not turn on \(the power indicator light does not turn on in green\)?](#)

[What should I do if my VAIO computer does not turn on or the power button does not work \(the power indicator light blinks fast\)?](#)

[What should I do if the power indicator light turns on in green when I press the power button but the screen remains blank?](#)

[Why does a message appear and Windows fail to start when I turn on my VAIO computer?](#)

[Why does my VAIO computer automatically turn off?](#)

[Why doesn't my VAIO computer enter Hibernate mode when the battery pack is running out of power?](#)

[Why doesn't my computer screen turn off after the automatic turn-off time has passed?](#)

[▶ How to Use](#)**Troubleshooting**[Hardware](#)[Software](#)[Network / Internet](#)[Backup / Recovery](#)[Security](#)[Peripheral Devices](#)

Touch pad

[How do I avoid unintentional clicks or movements of the pointer caused by a light touch on the touch pad?](#)[How do I disable the touch pad?](#)[What should I do if my VAIO computer screen freezes?](#)[What should I do if the pointer does not move?](#)[Why can't I use the touch pad?](#)

[▶ How to Use](#)

Troubleshooting

Hardware

Software

Network / Internet

Backup / Recovery

Security

Peripheral Devices

Wireless LAN

[How can I find the physical address \(MAC address\) of the built-in wireless network interface of my VAIO computer?](#)

[What should I do if I cannot connect my VAIO computer to an access point \(or the Internet\)?](#)

[What should I do if I cannot find \(the VAIO Smart Network icon\) in the desktop notification area?](#)

[What should I do if I cannot play back movies or audio tracks received via wireless LAN, or their playback is interrupted? Why is the data transfer speed slow?](#)

[What should I do if I cannot use the wireless LAN function?](#)

[What should I do if I do not know the SSID or security key for the access point?](#)

[What should I do if the text size on the website is small or large?](#)

[What should I do if the website is not displayed?](#)

[▶ How to Use](#)**Troubleshooting****Hardware**

Software

Network / Internet

Backup / Recovery

Security

Peripheral Devices

BIOS

[What should I do if I forget the power-on password to start my VAIO computer?](#)

[▶ How to Use](#)**Troubleshooting**[Hardware](#)[Software](#)[Network / Internet](#)[Backup / Recovery](#)[Security](#)[Peripheral Devices](#)

Battery

[What should I do if a message appears indicating that the battery pack is incompatible or has been incorrectly installed, after which my VAIO computer enters Hibernate mode?](#)

[Why can't I fully charge my battery pack?](#)

[Why doesn't my VAIO computer enter Hibernate mode when the battery pack is running out of power?](#)

[Why is my VAIO computer running slowly and the CPU clock frequency low while the computer is running on battery power?](#)

[▶ How to Use](#)**Troubleshooting****Hardware**

Software

Network / Internet

Backup / Recovery

Security

Peripheral Devices

Computer[Why does the System Properties window display a slower CPU speed than the maximum?](#)[Why is my VAIO computer running slowly and the CPU clock frequency low while the computer is running on battery power?](#)

[▶ How to Use](#)

Troubleshooting

Hardware

Software

Network / Internet

Backup / Recovery

Security

Peripheral Devices

Floppy disk

[What should I do if I cannot boot my VAIO computer from the floppy disk drive?](#)

You might be looking for the following topics:

[What should I do if I cannot remove my floppy disk?](#)[What should I do if I cannot save data on my floppy disk?](#)[What should I do if my VAIO computer does not recognize the floppy disk?](#)

[▶ How to Use](#)**Troubleshooting**[Hardware](#)[Software](#)[Network / Internet](#)[Backup / Recovery](#)[Security](#)[Peripheral Devices](#)

Keyboard

[What should I do if I cannot enter certain characters with my keyboard?](#)[What should I do if my VAIO computer screen freezes?](#)[What should I do if my keyboard configuration is wrong?](#)[What should I do if the pointer does not move?](#)

[▶ How to Use](#)**Troubleshooting****Hardware**

Software

Network / Internet

Backup / Recovery

Security

Peripheral Devices

Memory card

[Why can't I write data to a memory card?](#)[Why doesn't the memory card icon appear in the Computer window?](#)[Why doesn't the "Memory Stick" icon appear in the Computer window?](#)

[▶ How to Use](#)**Troubleshooting**[Hardware](#)[Software](#)[Network / Internet](#)[Backup / Recovery](#)[Security](#)[Peripheral Devices](#)

Password

[What should I do if I forget the Windows password?](#)[What should I do if I forget the power-on password to start my VAIO computer?](#)[What should I do if the Enter Onetime Password message appears and Windows does not start after I enter a wrong power-on password three times consecutively?](#)

[▶ How to Use](#)**Troubleshooting**[Hardware](#)[Software](#)[Network / Internet](#)[Backup / Recovery](#)[Security](#)[Peripheral Devices](#)

Software

[Why do sound interruptions and/or dropped frames occur when I play high-definition videos, such as those recorded with the AVCHD digital video camcorder?](#)

You might be looking for the following topics:

[What should I do if my game software does not work or it keeps crashing?](#)

[▶ How to Use](#)**Troubleshooting****Hardware**

Software

Network / Internet

Backup / Recovery

Security

Peripheral Devices

USB

[What should I do if I cannot boot my VAIO computer from the floppy disk drive?](#)

[What should I do if I cannot charge the device connected to the USB port that supports USB charging?](#)

You might be looking for the following topics:

[What should I do if I cannot print a document?](#)

[What should I do if I cannot remove my floppy disk?](#)

[What should I do if I cannot save data on my floppy disk?](#)

[What should I do if my VAIO computer does not recognize the USB device?](#)

[What should I do if my VAIO computer does not recognize the floppy disk?](#)

[▶ How to Use](#)

Troubleshooting

[Hardware](#)[Software](#)[Network / Internet](#)

[Backup / Recovery](#)

[Security](#)

[Peripheral Devices](#)

Display

[Why do sound interruptions and/or dropped frames occur when I play high-definition videos, such as those recorded with the AVCHD digital video camcorder?](#)

You might be looking for the following topics:

[How do I change the LCD brightness?](#)

[What should I do if I cannot see proper images on the computer screen?](#)

[What should I do if black bars appear along the top, bottom, and sides of the computer screen or an external display when I display images?](#)

[What should I do if captured images contain dropped frames and audio interruptions?](#)

[What should I do if captured images flicker?](#)

[What should I do if my VAIO computer screen freezes?](#)

[What should I do if my computer screen goes blank?](#)

[What should I do if no image is displayed on my TV screen or external display connected to the HDMI output port?](#)

[What should I do if no image is displayed on my external display or TV screen?](#)

[What should I do if some items do not fit on the computer screen?](#)

[What should I do if the top, bottom, and sides of images are not displayed because they are too large to fit on the computer screen or an external display?](#)

[What should I do if videos are not displayed on the computer screen?](#)

[What should I do if videos are not displayed smoothly?](#)

[Why does the viewfinder show no images or poor-quality images?](#)

[▶ How to Use](#)

Troubleshooting

[Hardware](#)[Software](#)[Network / Internet](#)

[Backup / Recovery](#)

[Security](#)

[Peripheral Devices](#)

Software

[What should I do if my game software does not work or it keeps crashing?](#)

[Why do sound interruptions and/or dropped frames occur when I play high-definition videos, such as those recorded with the AVCHD digital video camcorder?](#)

[▶ How to Use](#)**Troubleshooting**

[Hardware](#)

[Software](#)[Network / Internet](#)[Backup / Recovery](#)

[Security](#)

[Peripheral Devices](#)

BLUETOOTH

[What should I do if I cannot find the BLUETOOTH\(R\) device I want to communicate with?](#)

[What should I do if I cannot use the BLUETOOTH\(R\) function?](#)

[What should I do if other BLUETOOTH\(R\) devices cannot connect to my VAIO computer?](#)

[What should I do if the BLUETOOTH\(R\) icon is not displayed in the desktop notification area?](#)

[Why can't I exchange business card data with a smartphone or a mobile phone?](#)

[Why can't I use BLUETOOTH\(R\) devices when I switch users?](#)

[Why can't I use the BLUETOOTH\(R\) function when I log onto my VAIO computer as a user with a standard user account?](#)

[Why is my BLUETOOTH\(R\) connection slow?](#)

[▶ How to Use](#)

Troubleshooting

[Hardware](#)

[Software](#)[Network / Internet](#)[Backup / Recovery](#)

[Security](#)

[Peripheral Devices](#)

Wireless LAN

[How can I find the physical address \(MAC address\) of the built-in wireless network interface of my VAIO computer?](#)

[What should I do if I cannot connect my VAIO computer to an access point \(or the Internet\)?](#)

[What should I do if I cannot find \(the VAIO Smart Network icon\) in the desktop notification area?](#)

[What should I do if I cannot play back movies or audio tracks received via wireless LAN, or their playback is interrupted? Why is the data transfer speed slow?](#)

[What should I do if I cannot use the wireless LAN function?](#)

[What should I do if I do not know the SSID or security key for the access point?](#)

[What should I do if the text size on the website is small or large?](#)

[What should I do if the website is not displayed?](#)

[▶ How to Use](#)

Troubleshooting

[Hardware](#)

[Software](#)[Network / Internet](#)[Backup / Recovery](#)

[Security](#)

[Peripheral Devices](#)

LAN

[How can I find the physical address \(MAC address\) of the built-in wireless network interface of my VAIO computer?](#)

[What should I do if I cannot connect my VAIO computer to an access point \(or the Internet\)?](#)

[What should I do if I cannot find \(the VAIO Smart Network icon\) in the desktop notification area?](#)

[What should I do if I cannot play back movies or audio tracks received via wireless LAN, or their playback is interrupted? Why is the data transfer speed slow?](#)

[What should I do if I cannot use the wireless LAN function?](#)

[What should I do if I do not know the SSID or security key for the access point?](#)

[What should I do if the text size on the website is small or large?](#)

[What should I do if the website is not displayed?](#)

[▶ How to Use](#)

Troubleshooting

[Hardware](#)

[Software](#)

[Network / Internet](#)

[Backup / Recovery](#)

[Security](#)

[Peripheral Devices](#)

Floppy disk

[What should I do if I cannot boot my VAIO computer from the floppy disk drive?](#)

You might be looking for the following topics:

[What should I do if I cannot remove my floppy disk?](#)

[What should I do if I cannot save data on my floppy disk?](#)

[What should I do if my VAIO computer does not recognize the floppy disk?](#)

[▶ How to Use](#)

Troubleshooting

[Hardware](#)

[Software](#)

[Network / Internet](#)[Backup / Recovery](#)[Security](#)

[Peripheral Devices](#)

USB

[What should I do if I cannot boot my VAIO computer from the floppy disk drive?](#)

You might be looking for the following topics:

[What should I do if I cannot charge the device connected to the USB port that supports USB charging?](#)

[What should I do if I cannot print a document?](#)

[What should I do if I cannot remove my floppy disk?](#)

[What should I do if I cannot save data on my floppy disk?](#)

[What should I do if my VAIO computer does not recognize the USB device?](#)

[What should I do if my VAIO computer does not recognize the floppy disk?](#)

[▶ How to Use](#)**Troubleshooting**

[Hardware](#)

[Software](#)

[Network / Internet](#)

[Backup / Recovery](#)

[Security](#)

[Peripheral Devices](#)

Recovery[How can I reinstall the original software and drivers?](#)[How can I restore my VAIO computer system to its factory default settings?](#)[How do I create Recovery Media?](#)[What should I do if I cannot complete the recovery process?](#)[What should I do if I cannot create Recovery Media?](#)[What should I do if I cannot recover my VAIO computer from the recovery area?](#)[What should I do if my VAIO computer becomes unstable \(Windows does not start\)?](#)[What should I do if my VAIO computer becomes unstable \(Windows starts\)?](#)

[▶ How to Use](#)

Troubleshooting

Hardware

Software

Network / Internet

Backup / Recovery

Security

Peripheral Devices

BIOS

[What should I do if I forget the power-on password to start my VAIO computer?](#)

[▶ How to Use](#)**Troubleshooting**

[Hardware](#)

[Software](#)

[Network / Internet](#)

[Backup / Recovery](#)

[Security](#)

[Peripheral Devices](#)

Password[What should I do if I forget the Windows password?](#)[What should I do if I forget the power-on password to start my VAIO computer?](#)[What should I do if the Enter Onetime Password message appears and Windows does not start after I enter a wrong power-on password three times consecutively?](#)

[▶ How to Use](#)**Troubleshooting**

[Hardware](#)

[Software](#)

[Network / Internet](#)

[Backup / Recovery](#)

[Security](#)[Peripheral Devices](#)**Floppy disk**[What should I do if I cannot boot my VAIO computer from the floppy disk drive?](#)[What should I do if I cannot remove my floppy disk?](#)[What should I do if I cannot save data on my floppy disk?](#)[What should I do if my VAIO computer does not recognize the floppy disk?](#)

[▶ How to Use](#)**Troubleshooting**

[Hardware](#)

[Software](#)

[Network / Internet](#)

[Backup / Recovery](#)

[Security](#)[Peripheral Devices](#)**USB**[What should I do if I cannot boot my VAIO computer from the floppy disk drive?](#)[What should I do if I cannot print a document?](#)[What should I do if I cannot remove my floppy disk?](#)[What should I do if I cannot save data on my floppy disk?](#)[What should I do if my VAIO computer does not recognize the USB device?](#)[What should I do if my VAIO computer does not recognize the floppy disk?](#)

You might be looking for the following topics:

[What should I do if I cannot charge the device connected to the USB port that supports USB charging?](#)



[▶ How to Use](#)

Troubleshooting

Hardware

Software

Network / Internet

Backup / Recovery

Security

Peripheral Devices

Printer

[What should I do if I cannot print a document?](#)

[▶ How to Use](#)

Troubleshooting

[Hardware](#)

[Software](#)

[Network / Internet](#)

[Backup / Recovery](#)

[Security](#)

[Peripheral Devices](#)

What should I do if I forget the power-on password to start my VAIO computer?

- If you forget the password [\[Details\]](#), you cannot start your VAIO computer.
 - When you forget your user password:
Enter the machine password to reset the user password at the BIOS setup screen.
 - When you forget your machine password:
The password needs to be reset and a fee will be charged. To reset the password, contact an authorized Sony service/support center.
-

[▶ How to Use](#)**Troubleshooting**

[Hardware](#)

[Software](#)

[Network / Internet](#)

[Backup / Recovery](#)

[Security](#)

[Peripheral Devices](#)

What should I do if I do not hear sound from a digital audio device connected to the digital output port, such as the HDMI output port?

- To output sound from a digital audio device connected to the digital output port on your VAIO computer, you need to change the sound output to the digital audio device.

[\[Details\]](#)

[▶ How to Use](#)

Troubleshooting

[Hardware](#)

[Software](#)



[Network / Internet](#)

[Backup / Recovery](#)

[Security](#)

[Peripheral Devices](#)

What should I do if I do not hear sound from speakers or headphones?

- Check if the volume from speakers or headphones is not minimized.
 - Keep pressing the Fn+F4 keys to turn up the volume loud enough to hear sound. [\[Details\]](#)
 - Check if the volume in Windows is not turned off or minimized. [\[Details\]](#)
When the volume is turned off () , click  (Deactivate muting) to turn on the volume (). When the volume is minimized, turn up the volume.
 - When connecting external speakers or headphones, check the following:
 - Make sure external speakers or headphones are properly connected to your VAIO computer. [\[Details\]](#)
 - If external speakers require external power, make sure the speakers are securely connected to an AC outlet.
 - Make sure external speakers are turned on.
 - Make sure the volume from external speakers is not minimized.
 - Make sure the sound output device is correctly selected. [\[Details\]](#)
 - Check the volume on the playback software you are using.
-

[▶ How to Use](#)**Troubleshooting**

[Hardware](#)

[Software](#)

[Network / Internet](#)

[Backup / Recovery](#)

[Security](#)

[Peripheral Devices](#)

What should I do if I hear microphone feedback from speakers when using my microphone?

- Microphone feedback may occur when your microphone receives the sound from a sound output device, such as speakers.
 - Keep the microphone away from a sound output device.
 - Turn down the volume of the speakers and the microphone.
-

[▶ How to Use](#)

Troubleshooting

[Hardware](#)

[Software](#)

[Network / Internet](#)

[Backup / Recovery](#)

[Security](#)

[Peripheral Devices](#)

What should I do if my microphone does not work?

- Check if your microphone is selected as a recording device.
Click **Hardware** and **Sound** in the Control Panel window, select the **Recording** tab in the Sound window, and check if there is a check mark on your desired microphone icon. If not, select the icon and click **Set Default**. If the icon is not displayed, make sure the microphone is properly connected to your VAIO computer.
 - If you are using an external microphone, use a plug-in power microphone.
-

[▶ How to Use](#)

Troubleshooting

[Hardware](#)

[Software](#)

[Network / Internet](#)

[Backup / Recovery](#)

[Security](#)

[Peripheral Devices](#)

What should I do if sound interruptions occur during video or audio playback?

- Sound interruptions may occur when the CPU load is high. In this case, reduce the CPU load by exiting all running software other than playback software, or by disabling unnecessary audio effects applied to playback.
-

[▶ How to Use](#)**Troubleshooting**

[Hardware](#)

[Software](#)

[Network / Internet](#)

[Backup / Recovery](#)

[Security](#)

[Peripheral Devices](#)

What should I do if I cannot find the BLUETOOTH(R) device I want to communicate with?

- Shorten the distance between your VAIO computer and the BLUETOOTH device within 33 feet/10 meters.
If the computer is more than 33 feet/10 meters away from the BLUETOOTH device, communication will not be possible.
The computer may not be able to communicate with the BLUETOOTH device even within 33 feet/10 meters due to obstacles between the devices, radio wave quality, ambient environment that includes existence of walls and materials of such walls, or software in use. In such a case, move the computer away from obstructions or closer to the device.
- Check that the BLUETOOTH function of the device you want to communicate with is on, and the device is not in the power saving mode.
- Check that the BLUETOOTH function of the device you want to communicate with is enabled.
Refer to the manual that came with the device for more information.
- If the device you want to communicate with is already communicating with another BLUETOOTH device, it may not be found or it may not be able to communicate with your VAIO computer.

[▶ How to Use](#)

Troubleshooting

[Hardware](#)

[Software](#)



[Network / Internet](#)

[Backup / Recovery](#)

[Security](#)

[Peripheral Devices](#)

What should I do if I cannot use the BLUETOOTH(R) function?

- Make sure the WIRELESS indicator light on your VAIO computer is on.
 - When the WIRELESS indicator light is off, you cannot use the BLUETOOTH function.
 - Click  (Start), All Programs, and VAIO Smart Network or click  (the VAIO Smart Network icon) in the desktop notification area to open the VAIO Smart Network settings window.
Click each switch next to Wireless Functions and BLUETOOTH to toggle it to On.
 - Check whether the BLUETOOTH function is enabled.
Make sure the switch next to BLUETOOTH is toggled to On.
-

[▶ How to Use](#)

Troubleshooting

[Hardware](#)

[Software](#)



[Network / Internet](#)

[Backup / Recovery](#)

[Security](#)

[Peripheral Devices](#)

What should I do if other BLUETOOTH(R) devices cannot connect to my VAIO computer?

- See [What should I do if I cannot find the BLUETOOTH device I want to communicate with?](#). [\[Details\]](#)
- Make sure that the authentication (pairing) between the device and your VAIO computer has been properly performed.
Some BLUETOOTH devices require authentication (pairing) before establishing connection with another device. Perform the authentication process before connecting to such devices.
- Make sure that your VAIO computer allows BLUETOOTH devices to find the computer. Click  (arrow) in the desktop notification area, right-click  (the BLUETOOTH icon), and click Open Settings to open the settings window. Click the Options tab and make sure that the Allow Bluetooth devices to find this computer check box is selected.

[▶ How to Use](#)

Troubleshooting

[Hardware](#)

[Software](#)

[Network / Internet](#)

[Backup / Recovery](#)

[Security](#)

[Peripheral Devices](#)

What should I do if the BLUETOOTH(R) icon is not displayed in the desktop notification area?

- Make sure each switch next to Wireless Functions and BLUETOOTH is toggled to On in the VAIO Smart Network window.
 - Follow these steps to open the Bluetooth Settings window and check the settings: Click  (Start) and Devices and Printers. Right-click the BLUETOOTH device icon and click Bluetooth settings. Click the Options tab and select the Show the Bluetooth icon in the notification area check box.
-

[▶ How to Use](#)

Troubleshooting

[Hardware](#)

[Software](#)

[Network / Internet](#)

[Backup / Recovery](#)

[Security](#)

[Peripheral Devices](#)

Why can't I exchange business card data with a smartphone or a mobile phone?

- Your VAIO computer does not support the data transfer function (vCard Exchange), which exchanges business card data between BLUETOOTH devices (a smartphone, a mobile phone, etc.).
-

[▶ How to Use](#)

Troubleshooting

[Hardware](#)

[Software](#)

[Network / Internet](#)

[Backup / Recovery](#)

[Security](#)

[Peripheral Devices](#)

Why can't I use BLUETOOTH(R) devices when I switch users?

- If you switch users without logging off your system, BLUETOOTH devices will not work. Be sure to log off before switching users.
-

[▶ How to Use](#)**Troubleshooting**

[Hardware](#)

[Software](#)

[Network / Internet](#)

[Backup / Recovery](#)

[Security](#)

[Peripheral Devices](#)

Why can't I use the BLUETOOTH(R) function when I log onto my VAIO computer as a user with a standard user account?

- The BLUETOOTH function may not be available to a user with a standard user account on your VAIO computer.
Log onto the computer as a user with administrative rights.
-

[▶ How to Use](#)

Troubleshooting

[Hardware](#)

[Software](#)

[Network / Internet](#)

[Backup / Recovery](#)

[Security](#)

[Peripheral Devices](#)

Why is my BLUETOOTH(R) connection slow?

- Data transfer speed depends on obstructions and/or the distance between the two devices, radio wave quality, and the device configuration or software in use. Move your VAIO computer and BLUETOOTH device closer to each other.
 - If a version of a BLUETOOTH standard employed on the BLUETOOTH device with which you want to communicate is not the same version as the one employed on your VAIO computer, the communication speed may become slower.
 - If your VAIO computer is compliant with BLUETOOTH high speed technology and the following two conditions are met, high-speed communications are available. However, some BLUETOOTH profiles do not support high-speed communications.
 - The BLUETOOTH device with which you want to communicate supports BLUETOOTH high speed technology.
 - Both the wireless LAN and BLUETOOTH functions on the computer are enabled.
-

[▶ How to Use](#)

Troubleshooting

[Hardware](#)

[Software](#)

[Network / Internet](#)

[Backup / Recovery](#)

[Security](#)

[Peripheral Devices](#)

What should I do if captured images contain dropped frames and audio interruptions?

- The effect settings on your software application may cause dropped frames. Refer to the help file included with your software application for more information.
 - There may be more software applications running than your VAIO computer can handle. Exit the applications that you are not currently using.
 - This problem may occur while your VAIO computer is running on the power saving plan, which reduces the CPU performance. Check the current power plan. [\[Details\]](#)
-

[▶ How to Use](#)

Troubleshooting

[Hardware](#)

[Software](#)

[Network / Internet](#)

[Backup / Recovery](#)

[Security](#)

[Peripheral Devices](#)

What should I do if captured images flicker?

- This problem occurs when you use the built-in camera under fluorescent lights due to a mismatch between the lighting output frequency and the shutter speed.
To reduce flicker noise, change the direction of your VAIO computer so that you can adjust the direction of the built-in camera. Some software applications offer adjustable parameters, such as brightness, to eliminate flicker noise.
-

[▶ How to Use](#)

Troubleshooting

[Hardware](#)

[Software](#)

[Network / Internet](#)

[Backup / Recovery](#)

[Security](#)

[Peripheral Devices](#)

Why are captured images poor in quality?

- Images captured under fluorescent light may contain light reflections.
 - A dark portion in captured images may contain noise.
 - The area on and around the built-in camera is soiled. Clean the area. [\[Details\]](#)
-

[▶ How to Use](#)

Troubleshooting

[Hardware](#)

[Software](#)

[Network / Internet](#)

[Backup / Recovery](#)

[Security](#)

[Peripheral Devices](#)

Why does the viewfinder show no images or poor-quality images?

- The built-in camera cannot be shared by more than one software application. Exit the current application before starting another.
 - On models with VAIO Gesture Control or Media Gallery, you cannot use another camera application that uses the built-in camera while using the gesture function of the software.
 - The viewfinder may show some noise, for example horizontal streaks, when you are viewing a rapid-moving object. This is normal and does not indicate a malfunction.
 - If the problem persists, restart your VAIO computer.
-

[▶ How to Use](#)

Troubleshooting

[Hardware](#)

[Software](#)

[Network / Internet](#)

[Backup / Recovery](#)

[Security](#)

[Peripheral Devices](#)

Why is the video input from the built-in camera suspended momentarily?

- The video input may be suspended momentarily if:
 - A shortcut key with the Fn key is used.
 - The CPU load increases.
-

[▶ How to Use](#)

Troubleshooting

[Hardware](#)

[Software](#)

[Network / Internet](#)

[Backup / Recovery](#)

[Security](#)

[Peripheral Devices](#)

How do I change the LCD brightness?

- Press the Fn+F5 or Fn+F6 keys to adjust the LCD brightness of your VAIO computer.
[\[Details\]](#)
 - To adjust the LCD brightness of the connected external display, such as a computer display or a TV, use the brightness control on the external display.
-

[▶ How to Use](#)

Troubleshooting

[Hardware](#)

[Software](#)

[Network / Internet](#)

[Backup / Recovery](#)

[Security](#)

[Peripheral Devices](#)

What should I do if I cannot see proper images on the computer screen?

- Make sure the screen color setting is set to True Color (32 bit). Refer to Windows Help and Support for more information on how to change the setting.
-

[▶ How to Use](#)

Troubleshooting

[Hardware](#)

[Software](#)

[Network / Internet](#)

[Backup / Recovery](#)

[Security](#)

[Peripheral Devices](#)

What should I do if black bars appear along the top, bottom, and sides of the computer screen or an external display when I display images?

- Change the resolution (size) of the screen image. [\[Details\]](#)
 - If you are displaying images on an external display, such as a TV, connected to your VAIO computer with an HDMI cable (not supplied), adjust the screen resolution in the HDMI output resolution settings. [\[Details\]](#)
-

[▶ How to Use](#)

Troubleshooting

[Hardware](#)

[Software](#)



[Network / Internet](#)

[Backup / Recovery](#)

[Security](#)

[Peripheral Devices](#)

What should I do if my VAIO computer screen freezes?

- Restart your VAIO computer.
Press the Ctrl+Alt+Delete keys and click  (arrow) and Restart.
If the problem persists, press and hold down the  (Power) button for more than four seconds, or slide the  (Power) switch to the right for more than four seconds.
-

[▶ How to Use](#)

Troubleshooting

[Hardware](#)

[Software](#)



[Network / Internet](#)

[Backup / Recovery](#)

[Security](#)

[Peripheral Devices](#)

What should I do if my computer screen goes blank?

- Make sure your VAIO computer is on and not in a power saving mode. [\[Details\]](#)
- Make sure your VAIO computer is securely plugged into an AC outlet [\[Details\]](#) and the power indicator light is on.
- The computer screen may be off.
Press any key on the keyboard.
- The display output may be set to an external display.
Press the Fn+F7 keys several times to select your desired display output, and then press the Enter key. [\[Details\]](#)
- If your VAIO computer is running on battery power, make sure the battery pack is installed properly and is charged. [\[Details\]](#)
- If you wait for a while and the computer screen remains blank, follow the procedures below:
 - Press and hold down the  (Power) button for more than four seconds, check if the power indicator light is off, and then turn on your VAIO computer.
 - If the problem persists, press and hold down the  (Power) button for more than four seconds and check if the power indicator light is off. Disconnect all cables and peripheral devices, such as the power cord and the USB device, remove the battery pack, and wait about five minutes. Then, put them back in place and turn on your VAIO computer again.

[▶ How to Use](#)**Troubleshooting**

[Hardware](#)

[Software](#)

[Network / Internet](#)

[Backup / Recovery](#)

[Security](#)

[Peripheral Devices](#)

What should I do if no image is displayed on my TV screen or external display connected to the HDMI output port?

- Reconnect the HDMI cable (not supplied). [\[Details\]](#)
 - Make sure you are using an HDCP-compliant display. The copyright protected content is not displayed on a non-HDCP compliant display.
 - Change the screen resolution of the connected TV or external display. [\[Details\]](#) Images may appear on the screen.
-

[▶ How to Use](#)

Troubleshooting

[Hardware](#)

[Software](#)

[Network / Internet](#)

[Backup / Recovery](#)

[Security](#)

[Peripheral Devices](#)

What should I do if no image is displayed on my external display or TV screen?

- Press the Fn+F7 keys several times to select your desired display output, and then press the Enter key. [\[Details\]](#)
-

[▶ How to Use](#)

Troubleshooting

[Hardware](#)

[Software](#)

[Network / Internet](#)

[Backup / Recovery](#)

[Security](#)

[Peripheral Devices](#)

What should I do if some items do not fit on the computer screen?

- Check that the text size is set to 100%. If not, some items, for example a software menu, may not be displayed correctly, depending on the software you are using. Refer to Windows Help and Support for more information on how to change the text size.
-

[▶ How to Use](#)**Troubleshooting**

[Hardware](#)

[Software](#)

[Network / Internet](#)

[Backup / Recovery](#)

[Security](#)

[Peripheral Devices](#)

What should I do if the top, bottom, and sides of images are not displayed because they are too large to fit on the computer screen or an external display?

- Change the resolution (size) of the screen image. [\[Details\]](#)
 - If you are displaying images on an external display, such as a TV, connected to your VAIO computer with an HDMI cable (not supplied), adjust the screen resolution in the HDMI output resolution settings. [\[Details\]](#)
-

[▶ How to Use](#)

Troubleshooting

[Hardware](#)

[Software](#)

[Network / Internet](#)

[Backup / Recovery](#)

[Security](#)

[Peripheral Devices](#)

What should I do if videos are not displayed on the computer screen?

- The video memory of your VAIO computer may be insufficient for displaying high resolution videos. In such a case, lower the resolution of the LCD screen. [\[Details\]](#)
 - If the external display is selected as the display output with the Fn+F7 keys and is disconnected from your VAIO computer, the computer screen may become unable to display a video.
In such a case, stop video playback, press the Fn+F7 keys to select the computer screen as the display output, and then press the Enter key. Then, restart video playback.
-

[▶ How to Use](#)

Troubleshooting

[Hardware](#)

[Software](#)

[Network / Internet](#)

[Backup / Recovery](#)

[Security](#)

[Peripheral Devices](#)

What should I do if videos are not displayed smoothly?

- It is recommended you disable your screen saver.
If the screen saver is enabled, it may be activated during DVD playback and prevent the playback from running successfully. Some screen savers have been found to even change the display resolution and colors.
 - If you have set the display output to both the computer screen and an external display, change the display output to either of them.
 - If you have enabled Aero Themes for your desktop theme, change the current desktop theme.
Refer to Windows Help and Support for information on how to change the theme.
 - Some videos may not be displayed smoothly depending on the type or bit rate of videos. Lowering the screen resolution may improve video playback performance. [\[Details\]](#)
 - If data access to a memory card is in progress (the media access indicator light is on), wait until the data access ends and then start playback again.
 - If you are playing a video stored on the memory card, copy it to the built-in storage device and then play the copied video.
-

[▶ How to Use](#)**Troubleshooting**

[Hardware](#)

[Software](#)

[Network / Internet](#)

[Backup / Recovery](#)

[Security](#)

[Peripheral Devices](#)

Why do sound interruptions and/or dropped frames occur when I play high-definition videos, such as those recorded with the AVCHD digital video camcorder?

- Playing high-definition videos requires substantial hardware resources, such as CPU, GPU, or system memory performance on your VAIO computer. During the video playback, some operations and/or functions may become unavailable, and sound interruptions, dropped frames, and playback failure may occur depending on the configuration of the computer.
-

[▶ How to Use](#)**Troubleshooting**

[Hardware](#)

[Software](#)

[Network / Internet](#)

[Backup / Recovery](#)

[Security](#)

[Peripheral Devices](#)

How can I find the physical address (MAC address) of the built-in wireless network interface of my VAIO computer?

- If MAC address filtering of your access point is enabled, register the MAC address of your VAIO computer in the setup screen of the access point. Otherwise, the computer cannot connect to the access point.

Click  (Start), All Programs, Accessories, Command Prompt, and then enter "ipconfig /all" and press the Enter key. You can find the physical address (MAC address) in the Physical Address field under Wireless LAN adapter Wireless Network Connection:. Enter the address in the setup screen of the access point.

[▶ How to Use](#)**Troubleshooting**[Hardware](#)[Software](#)[Network / Internet](#)[Backup / Recovery](#)[Security](#)[Peripheral Devices](#)

What should I do if I cannot connect my VAIO computer to an access point (or the Internet)?

- See [What should I do if I cannot use the wireless LAN function?.](#) [\[Details\]](#)
- Make sure power to the access point is on.
- Check the access point settings.
In the following settings, your VAIO computer may fail to connect to an access point, or the connection may be unstable.
 - When the access point is set to refuse communication with a device whose SSID is set to “ANY,” and the SSID of your VAIO computer or the access point is set to “ANY.”
 - When the access point is in stealth mode.
For more information, refer to the manual that came with your access point, or consult your wireless LAN service provider.
- Make sure your VAIO computer and access point are connected to one another. [\[Details\]](#)
- Connection capability is affected by distance, obstructions, device configuration, radio wave strength/interference, wall materials, running software, etc.
Move your VAIO computer away from obstructions or closer to any access point you may be using.
- Check that your access point is displayed in the Currently connected to window. Click (Start), Control Panel, Network and Internet, Network and Sharing Center, and Connect to a network, and then check that your access point is displayed in the Currently connected to window.
- Make sure the security key is correct.
The security key is displayed as “*” for security reasons. Enter once more. [\[Details\]](#)
- Make sure that the wireless LAN function settings of your VAIO computer correspond with the settings of your access point. [\[Details\]](#)
- Make sure your VAIO computer is properly configured for Internet access.
If your antivirus software or firewall function of the Windows operating system imposes restrictions on Internet access, your VAIO computer may not connect to the Internet. Check the settings.
- Make sure Maximum Performance is selected for Wireless Adapter Settings in the Power Options window.
Click (Start), Control Panel, System and Security and Power Options. Click Change plan settings for the current power plan and Change advanced power settings. Select the Advanced settings tab and double-click Wireless Adapter Settings and Power Saving Mode, and then select Maximum Performance.

[▶ How to Use](#)**Troubleshooting**

[Hardware](#)

[Software](#)

[Network / Internet](#)

[Backup / Recovery](#)

[Security](#)

[Peripheral Devices](#)

What should I do if I cannot find  (the VAIO Smart Network icon) in the desktop notification area?

- Click  (arrow) in the desktop notification area to view all the icons.
-

[▶ How to Use](#)

Troubleshooting

[Hardware](#)

[Software](#)

[Network / Internet](#)

[Backup / Recovery](#)

[Security](#)

[Peripheral Devices](#)

What should I do if I cannot play back movies or audio tracks received via wireless LAN, or their playback is interrupted? Why is the data transfer speed slow?

- Move your VAIO computer away from obstructions, or closer to any access point you may be using.
Connection capability is affected by distance, obstructions, device configuration, radio wave strength/interference, wall materials, running software, etc.
- If you are using an access point, the device may be temporarily overloaded depending on how many other devices are communicating via the access point.
Wait for a while and try again.
- Change the channel setting of your access point. By changing the channel, interference on your wireless network may be reduced and data transfer speed may improve.
If access point channel interference occurs, data transfer speed may be reduced.
- If your access point interferes with other access points, change the access point channel.
Refer to the manual that came with your access point for more information.
- Make sure that a microwave oven is not operating near your wireless LAN devices.
The 2.4 GHz frequency band, on which the wireless LAN operates, is used by various devices and apparatus. If you use a microwave oven while communicating via wireless LAN, data transfer rate may slow down, communication range may narrow, or communication may be interrupted.
- Make sure Maximum Performance is selected for Wireless Adapter Settings in the Power Options window. [\[Details\]](#)

[▶ How to Use](#)

Troubleshooting

[Hardware](#)

[Software](#)

[Network / Internet](#)

[Backup / Recovery](#)

[Security](#)

[Peripheral Devices](#)

What should I do if I cannot use the wireless LAN function?

- Make sure each switch next to Wireless Functions and Wireless LAN (or Wi-Fi) is toggled to On in the VAIO Smart Network window.
 - To use the wireless LAN function on your VAIO computer, you need to set up the function.
Check the wireless LAN settings of the computer. [\[Details\]](#)
 - If connection utility software supplied with a third-party wireless LAN product is installed, uninstall it.
If connection utility software is installed, Windows may fail to configure the wireless LAN settings. Be sure to take a note of your settings, (such as security keys) before uninstalling.
-

[▶ How to Use](#)

Troubleshooting

[Hardware](#)

[Software](#)

[Network / Internet](#)

[Backup / Recovery](#)

[Security](#)

[Peripheral Devices](#)

What should I do if I do not know the SSID or security key for the access point?

- You can find the key in the setting screen of your access point.
Refer to the manual that came with your access point for more information.
-

[▶ How to Use](#)

Troubleshooting

[Hardware](#)

[Software](#)

[Network / Internet](#)

[Backup / Recovery](#)

[Security](#)

[Peripheral Devices](#)

What should I do if the text size on the website is small or large?

- Change the text size on your web browser.
If you use Internet Explorer, click Page and Text Size, and then select your desired text size.
-

[▶ How to Use](#)

Troubleshooting

[Hardware](#)

[Software](#)

[Network / Internet](#)

[Backup / Recovery](#)

[Security](#)



[Peripheral Devices](#)

What should I do if the website is not displayed?

- Depending on your Internet Service Provider (ISP), you may need to change the web browser settings.
Refer to the manual provided from your ISP to check the web browser settings.
 - Make sure the URL in the address bar is correct.
-

[▶ How to Use](#)**Troubleshooting**[Hardware](#)[Software](#)[Network / Internet](#)[Backup / Recovery](#)[Security](#)[Peripheral Devices](#)

What should I do if I cannot turn off my VAIO computer?

- Follow any of these procedures to exit all running software and then turn off your VAIO computer again.
 - Click the close button in the window of the running software.
 - Press the Alt+F4 keys.
 - If there is unsaved data, a message prompting you to save data appears. Click the button to save data.
 - Press the Alt+F4 keys until the Shut Down Windows window appears, select Shut down from the drop-down list, and click OK.
- If you have installed new software on your VAIO computer, check if the software is working properly, its data is normal, and you have operated it correctly.
- Contact the software publisher or designated provider for technical support.
- If you connect peripheral devices, such as a printer or a USB device, to your VAIO computer or connect the computer to your network, disconnect all peripheral devices or the computer's network connection and then turn off the computer.
 - While the computer is communicating with a peripheral device or the network, Windows does not allow you to turn off the computer. In addition, some peripheral device drivers for the peripheral devices do not support the feature to force the computer to shut down.
- If the computer screen freezes, press the Ctrl+Alt+Delete keys and click  (Shut down) in the lower right corner of the computer screen.
- If your VAIO computer freezes with a message indicating the settings are being saved or the computer is shutting down displayed, follow these procedures in order.
 - Press the Enter key.
 - Wait for a while.
 - If the problem persists, press the Ctrl+Alt+Delete keys.
 - Wait for a while.
- If you still cannot turn off your VAIO computer even after you follow all the above procedures in this topic, perform the following operations.
 - Note that performing these operations may cause working data to become corrupted. Be sure to disconnect the computer from the network before performing the following operations.
 - Press the Ctrl+Alt+Delete keys and click  (Shut down) in the lower right corner of the computer screen.
 - Press and hold down the  (Power) button for more than four seconds.
 - Unplug the AC adapter and remove the battery pack from your VAIO computer.

[▶ How to Use](#)

Troubleshooting

[Hardware](#)

[Software](#)



[Network / Internet](#)

[Backup / Recovery](#)

[Security](#)

[Peripheral Devices](#)

What should I do if VAIO Care Rescue starts when I turn on my VAIO computer?

- You may have pressed not the  (Power) button but the ASSIST button. Exit VAIO Care Rescue and check where the  (Power) button is located on your VAIO computer.
-

[▶ How to Use](#)

Troubleshooting

[Hardware](#)

[Software](#)

[Network / Internet](#)

[Backup / Recovery](#)

[Security](#)

[Peripheral Devices](#)

What should I do if my VAIO computer does not enter Hibernate mode?

- To place your VAIO computer into Hibernate mode, disable Rapid Wake in the Rapid Wake window on VAIO Control Center. [\[Details\]](#)
If you still cannot select Hibernate mode, click Change advanced power settings in the Power Options window and check if Allow hybrid sleep under Sleep is set to Off. If it is set to On, change it to Off. [\[Details\]](#)
-

[▶ How to Use](#)

Troubleshooting

[Hardware](#)

[Software](#)

[Network / Internet](#)

[Backup / Recovery](#)

[Security](#)

[Peripheral Devices](#)

What should I do if my VAIO computer does not enter Sleep mode?

- If the utility program, such as a printer utility program, is running, exit the program or temporarily disable it.
 - Depending on the type of your screen saver, your VAIO computer may not enter Sleep mode while the screen saver is activated.
 - Your VAIO computer may not enter Sleep mode if you execute a task on the computer before completely entering Sleep mode.
-

[▶ How to Use](#)

Troubleshooting

[Hardware](#)

[Software](#)



[Network / Internet](#)

[Backup / Recovery](#)

[Security](#)

[Peripheral Devices](#)

What should I do if my VAIO computer does not turn on (the power indicator light does not turn on in green)?

- Make sure all cables are securely connected to devices, such as between your VAIO computer and the AC adapter; the AC adapter and the power cord; and the power cord and an AC outlet. [\[Details\]](#)
- If you plug the power cord of your VAIO computer into a power strip with a switch, make sure the switch is turned on and the power cord of the power strip is securely plugged into an AC outlet.
- If you do not turn off your VAIO computer through the normal procedure, the power controller may be suspended due to a program error. Disconnect all cables and peripheral devices, such as the power cord and the USB device, remove the battery pack, and wait about five minutes. Then, put them back in place and turn on the computer again.
- Before using your VAIO computer for the first time, you need to connect the computer to a power source with the AC adapter.
- Check that you are using the supplied Sony AC adapter. For your safety, use only the genuine Sony rechargeable battery pack and AC adapter, which are supplied by Sony for your VAIO computer.
- Make sure the battery pack is installed properly.
- The battery pack may have run out of power.
- Make sure your VAIO computer is not in Hibernate mode by pressing the  (Power) button on the computer. Note that if you press and hold down the  (Power) button for more than four seconds, the computer will turn off.
- If you bring your VAIO computer directly from a cold location to a warm one, or use it in a high humidity location, moisture may condense inside the computer. In such a case, allow at least one hour before turning on the computer. Do not use the computer in a high humidity location (a relative humidity of more than 80 %), as it may cause the computer to malfunction.

[▶ How to Use](#)

Troubleshooting

[Hardware](#)

[Software](#)

[Network / Internet](#)

[Backup / Recovery](#)

[Security](#)



[Peripheral Devices](#)

What should I do if my VAIO computer does not turn on or the power button does not work (the power indicator light blinks fast)?

- The battery pack may not be installed properly.
Remove the battery pack and reinstall it properly. [\[Details\]](#)
 - If the problem persists, it means the installed battery is not compatible with your VAIO computer.
Remove the battery pack.
-

[▶ How to Use](#)**Troubleshooting**[Hardware](#)[Software](#)[Network / Internet](#)[Backup / Recovery](#)[Security](#)[Peripheral Devices](#)

What should I do if the power indicator light turns on in green when I press the power button but the screen remains blank?

- Make sure the brightness and contrast controls are adjusted correctly.
- An external display may be selected as the display output. Press the Fn+F7 keys several times to select your desired display output, and then press the Enter key.
- If you are using an external display, make sure it is plugged into an AC outlet and is on. Make sure the brightness and contrast controls are adjusted correctly. Refer to the manual that came with your display for information on how to change the settings.
- Press the Alt+F4 keys several times to close the application window. An application error may have occurred.
- If you wait for a while and the computer screen remains blank, restart your VAIO computer by following the procedures below in order. Note that following these procedures may cause working data to become corrupted.
 - Disconnect all peripheral devices, such as a printer or a USB device, and your VAIO computer from the network, if any.
 - Press and hold down the  (Power) button for more than four seconds and make sure the power indicator light is off. Then, turn on your VAIO computer again.
 - If the problem persists, press and hold down the  (Power) button for more than four seconds and make sure the power indicator light is off. Disconnect all cables connected to your VAIO computer, such as the AC adapter, remove the battery pack, and wait about five minutes. Then, put all cables, peripheral devices, and the battery pack back in place and turn on the computer again.
- If an extra memory module is not installed properly, your VAIO computer may not turn on. Use of memory modules not specified by Sony or improper installation of memory modules may cause the computer to fail to boot or to become unstable. In such a case, reinstall the memory module. If you use a memory module other than the Sony branded memory module, contact the sales dealer or the manufacturer of the memory module.
- If you bring your VAIO computer directly from a cold location to a warm one, or use it in a high humidity location, moisture may condense inside the computer. In such a case, allow at least one hour before turning on the computer. Do not use the computer in a high humidity location (a relative humidity of more than 80 %), as it may cause the computer to malfunction.

[▶ How to Use](#)

Troubleshooting

[Hardware](#)

[Software](#)

[Network / Internet](#)

[Backup / Recovery](#)

[Security](#)

[Peripheral Devices](#)

Why does a message appear and Windows fail to start when I turn on my VAIO computer?

- The BIOS boot options may have been incorrectly configured.
Turn on your VAIO computer, press the F2 key repeatedly until the VAIO logo disappears, and check if the Boot Mode option is available in the BIOS setup screen. If available, change the option.
-

[▶ How to Use](#)

Troubleshooting

[Hardware](#)

[Software](#)

[Network / Internet](#)

[Backup / Recovery](#)

[Security](#)

[Peripheral Devices](#)

Why does my VAIO computer automatically turn off?

- When the battery pack is running out of power, your VAIO computer automatically enters Hibernate mode and eventually turns off.
Connect the AC adapter to the computer or charge the battery pack.
-

[▶ How to Use](#)**Troubleshooting**

[Hardware](#)

[Software](#)

[Network / Internet](#)

[Backup / Recovery](#)

[Security](#)

[Peripheral Devices](#)

Why doesn't my VAIO computer enter Hibernate mode when the battery pack is running out of power?

- This problem occurs when Windows does not allow a task to be suspended, depending on the running software or the connected external device.
-

[▶ How to Use](#)

Troubleshooting

[Hardware](#)

[Software](#)

[Network / Internet](#)

[Backup / Recovery](#)

[Security](#)

[Peripheral Devices](#)

Why doesn't my computer screen turn off after the automatic turn-off time has passed?

- Some software applications or screen savers are designed to temporarily disable the feature of Windows that turns off the computer screen or places your VAIO computer into Sleep mode after a certain period of inactivity. To solve this problem, exit the running software application(s) or change the current screen saver.
-

[▶ How to Use](#)**Troubleshooting**

[Hardware](#)

[Software](#)

[Network / Internet](#)

[Backup / Recovery](#)

[Security](#)

[Peripheral Devices](#)

How do I avoid unintentional clicks or movements of the pointer caused by a light touch on the touch pad?

- To avoid unintentional operations, disable the tapping function. [\[Details\]](#)
-

[> How to Use](#)

Troubleshooting

[Hardware](#)

[Software](#)

[Network / Internet](#)

[Backup / Recovery](#)

[Security](#)

[Peripheral Devices](#)

How do I disable the touch pad?

- Press the Fn+F1 keys to disable the touch pad. [\[Details\]](#)
Alternatively, you can disable the touch pad in the VAIO Control Center window.
Click  (Start), All Programs, and VAIO Control Center to display the window.
-

[▶ How to Use](#)

Troubleshooting

[Hardware](#)

[Software](#)





[Network / Internet](#)

[Backup / Recovery](#)

[Security](#)

[Peripheral Devices](#)

What should I do if the pointer does not move?

- When the pointer does not move because your finger reached an edge of the touch pad, lift the finger off the touch pad and put it back on the center of the touch pad.
 - The pointer may not temporarily move against your intention depending on the software you are using.
In such a case, wait for a while before moving the pointer again.
If the pointer still does not move, press the Ctrl+Alt+Delete keys and click  (Shut down) in the lower right corner of the computer screen to turn off your VAIO computer.
If the problem persists, press and hold down the  (Power) button or slide the  (Power) switch to the right for more than four seconds.
Turning off the computer with the Ctrl+Alt+Delete keys, the  (Power) button, or the  (Power) switch may cause loss of unsaved data.
 - The touch pad may be disabled. [\[Details\]](#)
-

[▶ How to Use](#)

Troubleshooting

[Hardware](#)

[Software](#)

[Network / Internet](#)

[Backup / Recovery](#)

[Security](#)

[Peripheral Devices](#)

Why can't I use the touch pad?

- The touch pad is disabled.
 - Press the Fn+F1 keys to enable the touch pad. [\[Details\]](#)
Alternatively, you can click  (Start), All Programs, and VAIO Control Center, and then enable the touch pad in the VAIO Control Center window.
 - Disconnect a mouse from your VAIO computer, if it is connected.
-

[▶ How to Use](#)

Troubleshooting

[Hardware](#)

[Software](#)

[Network / Internet](#)

[Backup / Recovery](#)

[Security](#)

[Peripheral Devices](#)

What should I do if a message appears indicating that the battery pack is incompatible or has been incorrectly installed, after which my VAIO computer enters Hibernate mode?

- This problem could be due to the battery pack not being installed properly. To solve this problem, turn off your VAIO computer, remove the battery pack, and then reinstall it. [\[Details\]](#)
 - If the problem persists, it is likely that the installed battery pack is not compatible with your VAIO computer or has failed. Turn off the computer, remove the battery pack, and then replace it with a new one specified by Sony.
-

[▶ How to Use](#)**Troubleshooting**

[Hardware](#)

[Software](#)

[Network / Internet](#)

[Backup / Recovery](#)

[Security](#)

[Peripheral Devices](#)

Why can't I fully charge my battery pack?

- The battery care function is enabled on the VAIO Control Center to extend the life of your battery pack. Check the settings on the VAIO Control Center.
 - If ambient temperature is outside the specified range or the power consumption of your VAIO computer is high when you charge the battery pack, the charge current may be reduced.
-

[▶ How to Use](#)**Troubleshooting**

[Hardware](#)

[Software](#)

[Network / Internet](#)

[Backup / Recovery](#)

[Security](#)

[Peripheral Devices](#)

Why is my VAIO computer running slowly and the CPU clock frequency low while the computer is running on battery power?

- While your VAIO computer is running on battery power, the CPU clock frequency is reduced for power conserving purposes, which causes the computer to run slowly. This is normal and does not indicate a malfunction.
-

[▶ How to Use](#)**Troubleshooting**

[Hardware](#)

[Software](#)

[Network / Internet](#)

[Backup / Recovery](#)

[Security](#)

[Peripheral Devices](#)

Why does the System Properties window display a slower CPU speed than the maximum?

- This is normal. Because your VAIO computer's CPU utilizes a type of CPU speed controlling technology for power conservation purposes, the System Properties window may display the current CPU speed instead of the maximum speed.
-

[▶ How to Use](#)

Troubleshooting

[Hardware](#)

[Software](#)

[Network / Internet](#)

[Backup / Recovery](#)

[Security](#)

[Peripheral Devices](#)

What should I do if I cannot boot my VAIO computer from the floppy disk drive?

- Turn on your VAIO computer and press the F11 key repeatedly until the VAIO logo disappears.
If the computer does not boot, restart the computer and try again.
-

[▶ How to Use](#)**Troubleshooting**

[Hardware](#)

[Software](#)

[Network / Internet](#)

[Backup / Recovery](#)

[Security](#)

[Peripheral Devices](#)

What should I do if I cannot remove my floppy disk?

- Close open file(s), make sure the indicator light on the USB floppy disk drive is off, and then remove your floppy disk from the drive.
-

[▶ How to Use](#)

Troubleshooting

[Hardware](#)

[Software](#)

[Network / Internet](#)

[Backup / Recovery](#)

[Security](#)

[Peripheral Devices](#)

What should I do if I cannot save data on my floppy disk?

- Make sure your floppy disk is properly inserted in the USB floppy disk drive connected to your VAIO computer.
Make sure the floppy disk is right-side up before inserting it into the drive.
 - If a message indicating that your floppy disk is full appears, your floppy disk does not have enough free space.
Change the floppy disk to another with enough free space and then save data again.
 - If a message indicating that your floppy disk is write-protected appears, slide a write-protect tab on the floppy disk to disable the write-protect feature.
Sliding the write-protect tab to the open position enables the write-protect feature.
-

[▶ How to Use](#)

Troubleshooting

[Hardware](#)

[Software](#)

[Network / Internet](#)

[Backup / Recovery](#)

[Security](#)

[Peripheral Devices](#)

What should I do if my VAIO computer does not recognize the floppy disk?

- Make sure the floppy disk is properly inserted in the USB floppy disk drive connected to your VAIO computer.
Make sure the floppy disk is right-side up before inserting it into the drive.
 - Make sure the USB floppy disk drive is securely connected to your VAIO computer.
 - Remove the floppy disk from the USB floppy disk drive and then insert it again.
-

[▶ How to Use](#)

Troubleshooting

[Hardware](#)

[Software](#)

[Network / Internet](#)

[Backup / Recovery](#)

[Security](#)

[Peripheral Devices](#)

What should I do if I cannot enter certain characters with my keyboard?

- Check if the Num lock indicator light is on or off.
When the indicator light is on, you can enter the numbers printed on the keys.
When the indicator light is off, you can enter the letters and symbols printed on the keys.
Press the Num Lk key to turn the Num Lock indicator light on or off. [\[Details\]](#)
 - Check if the Caps Lock indicator light is on or off.
When the indicator light is on, characters typed will appear in uppercase (or lowercase if you also hold down the Shift key).
When the indicator light is off, characters typed will appear in lowercase (or uppercase if you also hold down the Shift key).
Press the Shift+Caps Lock keys to turn the Caps Lock indicator light on or off.
[\[Details\]](#)
-

[▶ How to Use](#)

Troubleshooting

[Hardware](#)

[Software](#)

[Network / Internet](#)

[Backup / Recovery](#)

[Security](#)

[Peripheral Devices](#)

What should I do if my keyboard configuration is wrong?

- The language layout of your keyboard is labeled on the packaging box. If you choose a different regional keyboard when you complete the Windows setup, the key configuration will be mismatched. To change the keyboard configuration, refer to Windows Help and Support.
-

[▶ How to Use](#)

Troubleshooting

[Hardware](#)

[Software](#)

[Network / Internet](#)

[Backup / Recovery](#)

[Security](#)

[Peripheral Devices](#)

Why can't I write data to a memory card?

- Some types of memory cards are equipped with an erasure prevention switch to protect data from unintentional erasure or overwriting. Make sure the erasure prevention switch is off.
-

[▶ How to Use](#)**Troubleshooting**

[Hardware](#)

[Software](#)

[Network / Internet](#)

[Backup / Recovery](#)

[Security](#)

[Peripheral Devices](#)

Why doesn't the memory card icon appear in the Computer window?

- The icon will not appear if no memory card is inserted in the slot.
-

[▶ How to Use](#)

Troubleshooting

[Hardware](#)

[Software](#)

[Network / Internet](#)

[Backup / Recovery](#)

[Security](#)

[Peripheral Devices](#)

Why doesn't the "Memory Stick" icon appear in the Computer window?

- The icon does not appear when no "Memory Stick" is inserted into the slot.
-

[▶ How to Use](#)

Troubleshooting

[Hardware](#)

[Software](#)

[Network / Internet](#)

[Backup / Recovery](#)

[Security](#)

[Peripheral Devices](#)

What should I do if I forget the Windows password?

- The Windows password is case-sensitive. Check your password and enter again.
 - Log on using a user account that has system administrator privileges to reset your password.
 - If you forget all passwords for system administrator accounts, you cannot reset any Windows passwords. You need to perform system recovery. [\[Details\]](#)
-

[▶ How to Use](#)

Troubleshooting

[Hardware](#)

[Software](#)

[Network / Internet](#)

[Backup / Recovery](#)

[Security](#)

[Peripheral Devices](#)

What should I do if the Enter Onetime Password message appears and Windows does not start after I enter a wrong power-on password three times consecutively?

- Press and hold down the  (Power) button for more than four seconds and check if the power indicator light is off. Then, restart your VAIO computer and enter the correct password.
The password is case-sensitive, so be sure to check letters for the current case before you enter the password.
 - If you forget the power-on password, you cannot start your VAIO computer. [\[Details\]](#)
-

[▶ How to Use](#)

Troubleshooting

[Hardware](#)

[Software](#)

[Network / Internet](#)

[Backup / Recovery](#)

[Security](#)

[Peripheral Devices](#)

What should I do if my game software does not work or it keeps crashing?

- Check the website of the game if there are any patches or updates to download.
 - Make sure you have installed the latest video driver software.
 - On some VAIO computer models, the graphics memory is shared with the system. The optimal graphics performance in such a case is not guaranteed.
-

[▶ How to Use](#)**Troubleshooting**

[Hardware](#)

[Software](#)

[Network / Internet](#)

[Backup / Recovery](#)

[Security](#)

[Peripheral Devices](#)

What should I do if I cannot charge the device connected to the USB port that supports USB charging?

- Make sure that USB Charging Settings is enabled. [\[Details\]](#)
-

[▶ How to Use](#)

Troubleshooting

[Hardware](#)

[Software](#)

[Network / Internet](#)

[Backup / Recovery](#)

[Security](#)

[Peripheral Devices](#)

What should I do if I cannot print a document?

- Make sure the printer settings are correctly configured.
For information on the printer settings, refer to the manual that came with your printer.
- Make sure your printer is on.
Refer to the manual that came with your printer for more information.
- Make sure the connections between the printer's power cord and AC adapter and between the AC adapter and an AC outlet are securely made.
- Make sure the appropriate printer driver is installed.
When you connect a new printer, you first need to set up the printer driver. For information on how to set up the printer driver, refer to the manual that came with your printer, or visit the website of the manufacturer.
- Make sure the status of your printer is displayed as online or ready. Then, make sure the printer settings are correctly configured as instructed in the manual that came with the printer.
- Make sure your printer is set to Set as Default Printer. Refer to Windows Help and Support for more information.
- Make sure your printer is compatible with Windows installed on your VAIO computer.
- Make sure your printer is connected to your network (LAN).
If the printer is directly connected to the network (LAN), make sure a router or a hub is on.
If the printer is connected to a printer server, make sure an error message is not displayed on the printer server.
- Make sure your software is working properly.
The software may not support your document format. In such a case, your document will not be printed properly. Contact the software publisher or the manufacturer of your printer.
- Make sure the correct printer port for your printer is selected.
For more information on the printer port settings, refer to the manual that came with the printer, or contact the manufacturer.

[▶ How to Use](#)

Troubleshooting

[Hardware](#)

[Software](#)

[Network / Internet](#)

[Backup / Recovery](#)

[Security](#)

[Peripheral Devices](#)

What should I do if my VAIO computer does not recognize the USB device?

- Check if the USB device is on and using its own power supply.
 - If you are using a digital camera, check if the battery is charged.
 - If you are using a printer, check if the power cable is connected properly to an AC outlet.
 - You may need to install a USB driver for the USB device before connecting the device. Refer to the manual that came with the USB device for more information.
 - Try using another USB port on your VAIO computer. The USB driver could be installed to the specific port you used the first time you connected the device.
 - USB hubs may prevent the USB device from working because of a power distribution failure. We recommend you connect the device directly to your VAIO computer without a hub.
-

[▶ How to Use](#)

Troubleshooting

[Hardware](#)

[Software](#)

[Network / Internet](#)

[Backup / Recovery](#)

[Security](#)

[Peripheral Devices](#)

How can I reinstall the original software and drivers?

- You can restore the preinstalled software and drivers using VAIO Care. To restore them, start VAIO Care [\[Details\]](#) and then click Advanced Tools, Restore and recovery, and Reinstall applications and drivers. Refer to the help file included with VAIO Care for more information.
-

[▶ How to Use](#)

Troubleshooting

[Hardware](#)

[Software](#)

[Network / Internet](#)

[Backup / Recovery](#)

[Security](#)

[Peripheral Devices](#)

How can I restore my VAIO computer system to its factory default settings?

- There are two ways to recover your VAIO computer system: from Recovery Media [\[Details\]](#) and from the recovery area [\[Details\]](#).
-

[▶ How to Use](#)**Troubleshooting**

[Hardware](#)

[Software](#)

[Network / Internet](#)

[Backup / Recovery](#)

[Security](#)

[Peripheral Devices](#)

How do I create Recovery Media?

- You can create Recovery Media using VAIO Care. [\[Details\]](#)
-

[▶ How to Use](#)

Troubleshooting

[Hardware](#)

[Software](#)

[Network / Internet](#)

[Backup / Recovery](#)

[Security](#)

[Peripheral Devices](#)

What should I do if I cannot complete the recovery process?

- Disconnect all unnecessary external devices from your VAIO computer.
 - Try the suggestions below:
 - Check the condition of Recovery Media. If you are using optical discs, check the discs for dirt or damage. If the discs are not clean, clean them and try recovering your VAIO computer again.
 - If you cannot recover your VAIO computer from the recovery area, restart the computer and recover the computer from the recovery area again, or use Recovery Media.
 - If you cannot recover your VAIO computer using a USB optical drive or USB flash drive, connect the drive to another USB port on the computer, then turn off the computer and try recovering it again.
 - If the problem persists, visit the VAIO online support website for further assistance.
-

[▶ How to Use](#)

Troubleshooting

[Hardware](#)

[Software](#)

[Network / Internet](#)

[Backup / Recovery](#)

[Security](#)

[Peripheral Devices](#)

What should I do if I cannot create Recovery Media?

- Try the suggestions below:
 - Download and install the latest updates using VAIO Update.
 - Restart your VAIO computer. And then, try to create Recovery Media again.
 - If an AC adapter is supplied with an external optical disc drive, plug the AC adapter into a power source.
 - Try other reliable media.
 - If the problem persists, visit the VAIO online support website for further assistance.
-

[▶ How to Use](#)

Troubleshooting

[Hardware](#)

[Software](#)

[Network / Internet](#)

[Backup / Recovery](#)

[Security](#)

[Peripheral Devices](#)

What should I do if I cannot recover my VAIO computer from the recovery area?

- Recover your VAIO computer from Recovery Media if you have used software to modify the recovery area, installed a different operating system from the preinstalled one, or formatted the built-in storage device without using VAIO Care Rescue.
 - If the problem persists, visit the VAIO online support website for further assistance.
-

[▶ How to Use](#)

Troubleshooting

[Hardware](#)

[Software](#)

[Network / Internet](#)

[Backup / Recovery](#)

[Security](#)

[Peripheral Devices](#)

What should I do if my VAIO computer becomes unstable (Windows does not start)?

- Try the suggestions below:
 - Restore computer system files. [\[Details\]](#)
Use the restore point that you created before your VAIO computer becomes unstable.
 - Restore your VAIO computer from a system image backup if you have created the backup. Refer to Windows Help and Support for more information.
Any file you have created or changed after you created the system image backup will not be restored. You need to back up such a file with VAIO Care Rescue. [\[Details\]](#)
- Use VAIO Hardware Diagnostics to identify problems on your VAIO computer.
 - With the software, you can check if the computer hardware (a CPU, a memory module, and a built-in storage device) needs to be replaced. To start VAIO Hardware Diagnostics, click Tools and VAIO Hardware Diagnostics in VAIO Care Rescue.
- Follow the instructions in Recovering from the Recovery Area to recover your VAIO computer. [\[Details\]](#)
 - If you have not backed up your data, be sure to make a backup copy of your valuable data using VAIO Care Rescue before recovering your VAIO computer. [\[Details\]](#)
If you have a backup created with the Windows backup feature before your VAIO computer becomes unstable, but you have created or changed the file after that, back up such a file with VAIO Care Rescue.

Note

- Recovering your VAIO computer will delete all the data on the built-in storage device.

[▶ How to Use](#)

Troubleshooting

[Hardware](#)

[Software](#)

[Network / Internet](#)

[Backup / Recovery](#)

[Security](#)

[Peripheral Devices](#)

What should I do if my VAIO computer becomes unstable (Windows starts)?

- Try the suggestions below:
 - Start VAIO Care to search for a solution. [\[Details\]](#)
 - Restore computer system files. [\[Details\]](#)
Use the restore point that you created before your VAIO computer becomes unstable.
 - Uninstall software or a software driver if your VAIO computer has become unstable after you installed the software or the software driver.
 - Reinstall the preinstalled software or software drivers on your VAIO computer if such software or software drivers have not been working properly. [\[Details\]](#)
 - Restore your VAIO computer from a system image backup if you have created the backup. Refer to Windows Help and Support for more information.
- If the problem persists, follow the instructions in Recovering from the Recovery Area to recover your VAIO computer. [\[Details\]](#)
 - If you have not yet created Recovery Media, create the Recovery Media. [\[Details\]](#)
 - Be sure to make a backup copy of your valuable data before recovering your VAIO computer. Refer to Windows Help and Support for more information.

Note

- Recovering your VAIO computer will delete all the data on the built-in storage device.