



VAIO Digital Studio® Computer

VGC-RA820G Series

VGC-RA920G Series

Quick Start

SONY®

Notice

© 2004 Sony Electronics Inc. Reproduction in whole or in part without written permission is prohibited. All rights reserved. This manual and the software described herein, in whole or in part, may not be reproduced, translated, or reduced to any machine-readable form without prior written approval.

SONY ELECTRONICS INC. PROVIDES NO WARRANTY WITH REGARD TO THIS MANUAL, THE SOFTWARE, OR OTHER INFORMATION CONTAINED HEREIN AND HEREBY EXPRESSLY DISCLAIMS ANY IMPLIED WARRANTIES OF MERCHANTABILITY OR FITNESS FOR ANY PARTICULAR PURPOSE WITH REGARD TO THIS MANUAL, THE SOFTWARE, OR SUCH OTHER INFORMATION. IN NO EVENT SHALL SONY ELECTRONICS INC. BE LIABLE FOR ANY INCIDENTAL, CONSEQUENTIAL, OR SPECIAL DAMAGES, WHETHER BASED ON TORT, CONTRACT, OR OTHERWISE, ARISING OUT OF OR IN CONNECTION WITH THIS MANUAL, THE SOFTWARE, OR OTHER INFORMATION CONTAINED HEREIN OR THE USE THEREOF.

SONY CANNOT WARRANT THAT THE FUNCTIONS DESCRIBED IN THIS GUIDE WILL BE UNINTERRUPTED OR ERROR-FREE. SONY ALSO ASSUMES NO RESPONSIBILITY, AND SHALL NOT BE LIABLE FOR ANY DAMAGES TO, OR VIRUSES THAT MAY INFECT, YOUR COMPUTER EQUIPMENT, OR OTHER PROPERTY ON ACCOUNT OF YOUR ACCESS TO, USE OF, OR BROWSING IN ANY DESCRIBED WEB SITE, OR YOUR DOWNLOADING OF ANY MATERIALS, DATA, TEXT, IMAGES, VIDEO, OR AUDIO FROM ANY DESCRIBED WEB SITE. WEB SITE INFORMATION IS OBTAINED FROM VARIOUS SOURCES AND MAY BE INACCURATE. COPIES OF COPYRIGHTED INFORMATION MAY ONLY BE MADE FOR LEGALLY PERMISSIBLE PURPOSES.

Sony Electronics Inc. reserves the right to make any modification to this manual or the information contained herein at any time without notice. The software described herein is governed by the terms of a separate user license agreement.

This product contains software owned by Sony and licensed by third parties. Use of such software is subject to the terms and conditions of license agreements enclosed with this product. Some of the software may not be transported or used outside the United States. Software specifications are subject to change without notice and may not necessarily be identical to current retail versions.

Certain product(s) included with this computer may include features such as copy protection and content management technology. USE OF THE SOFTWARE PRODUCT(S) REQUIRES AGREEMENT TO APPLICABLE END USER AGREEMENTS AND FULL COMPLIANCE WITH APPLICABLE PRODUCT ACTIVATION PROCEDURES. Product activation procedures and privacy policies will be detailed during initial launch of the software product(s), or upon certain reinstallations of the software product(s), or reconfigurations of the computer, and may be completed by Internet or telephone (toll charges may apply).

Updates and additions to software may require an additional charge. Subscriptions to online service providers may require a fee and credit card information. Financial services may require prior arrangements with participating financial institutions.

Important information for Canadian customers: Your new VAIO computer includes certain software versions or upgrades, and Internet services or offers that are available to U.S. customers only.

Sony, VAIO, the VAIO logo, VAIO Digital Studio, VAIO Media, VAIO Media Music Server, VAIO Media Photo Server, VAIO Media Video Server, Click to DVD, CLIE, DVgate Plus, Handycam, MagicGate, Memory Stick, Memory Stick Duo, the Memory Stick logo, OpenMG, MICROMV, SonicStage, PictureGear, ImageStation, ATRAC3, and i.LINK are trademarks or registered trademarks of Sony.

Intel and Pentium are trademarks or registered trademarks of the Intel Corporation.

Microsoft, Windows, and the Windows logo are trademarks or registered trademarks of the Microsoft Corporation.

PS/2 is a registered trademark of the IBM Corporation.

All other trademarks are trademarks or registered trademarks of their respective owners.



As an ENERGY STAR® Partner, Sony Corporation has determined that this product meets the ENERGY STAR® guidelines for energy efficiency.

The International ENERGY STAR® Office Equipment Program is an international program that promotes energy saving through the use of computers and other office equipment. The program backs the development and dissemination of products with functions that effectively reduce energy consumption. It is an open system in which business proprietors can participate voluntarily. The targeted products are office equipment such as computers, displays, printers, facsimiles and copiers. Their standards and logos are uniform among participating nations. ENERGY STAR is a U.S. registered trademark of the Environmental Protection Agency.

Owner's Record

The model number and serial number are located on the back panel of your Sony VAIO® computer. Record the model and serial number in the space provided here, and keep in a secure location. Refer to the model and serial numbers when you call your Sony Service Center.

Model Number:	
Serial Number:	

Safety Information and Caution

Your computer's installed optical drives may vary, depending on the system configuration you have purchased. See the online specifications sheet for details on your installed optical drives. For questions regarding your product or for the Sony Service Center nearest you, visit the Sony online support Web site at <http://www.sony.com/pcsupport>.

- To prevent fire or shock hazard, do not expose your desktop to rain or moisture.
- To avoid electrical shock, do not open the cabinet. Refer servicing to qualified personnel only.
- Never install modem or telephone wiring during a lightning storm.
- Never install telephone jacks in wet locations unless the jack is specifically designed for wet locations.
- Never touch uninsulated telephone wire or terminals unless the telephone line has been disconnected at the network interface.
- Use caution when installing or modifying telephone lines.
- Avoid using the modem during an electrical storm.
- Do not use the modem or a telephone to report a gas leak in the vicinity of the leak.
- The socket outlet shall be installed near the equipment and shall be easily accessible.



To change the backup battery, please contact your nearest Sony Service Center.



Caution—The use of optical instruments with this product will increase eye hazard. As the laser beam used in this product is harmful to the eyes, do not attempt to disassemble the drive cabinet. Refer servicing to qualified personnel only.



Danger—Visible and invisible laser radiation when open. Avoid direct exposure to beam.



For DVD±RW/DVD-ROM: Danger—Visible and invisible laser radiation when open. Avoid direct exposure to beam.



For CD-RW: Danger—Invisible laser radiation when open. Avoid direct exposure to beam.



Caution—For ADSL and V.90 modem models; to reduce the risk of fire, use only No. 26 AWG or larger telecommunication line cord.

- Pour prévenir tout risque d'incendie ou d'électrocution, garder cet appareil à l'abri de la pluie et de l'humidité.
- Pour prévenir tout risque d'électrocution, ne pas ouvrir le châssis de cet appareil et ne confier son entretien qu'à une personne qualifiée.
- Ne jamais effectuer l'installation de fil modem ou téléphone durant un orage électrique.
- Ne jamais effectuer l'installation d'une prise téléphonique dans un endroit mouillé à moins que la prise soit conçue à cet effet.
- Ne jamais toucher un fil téléphonique à découvert ou un terminal à moins que la ligne téléphonique n'ait été débranché de l'interface réseau.
- Soyez très prudent lorsque vous installez ou modifiez les lignes téléphoniques.
- Évitez d'utiliser le modem durant un orage électrique.
- N'utilisez pas le modem ni le téléphone pour prévenir d'une fuite de gaz si vous êtes près de la fuite.
- L'appareil doit être le plus près possible d'une prise murale pour en faciliter l'accès.



Pour changer la pile de rechange, veuillez contacter votre centre de service Sony le plus près.



Avertissement: L'utilisation d'instruments optiques avec ce produit augmente les risques pour les yeux. Puisque le faisceau laser utilisé dans ce produit est dommageable pour les yeux, ne tentez pas de désassembler le boîtier. Adressez-vous à un agent de service qualifié.



Danger: Radiation laser visible et invisible si ouvert. Évitez l'exposition directe au faisceau.



Pour les DVD±RW/DVD-ROM: Danger—Radiation laser visible et invisible si ouvert. Évitez l'exposition directe au faisceau.



Pour les CD-RW: Danger—Radiation laser invisible si ouvert. Évitez l'exposition directe au faisceau.



Attention: Pour ADSL et V.90 modele modem; afin de réduire les risques d'incendie, n'utilisez qu'un cordon de communication NO. 26 AWG ou plus gros.

Regulatory Information

If you have questions about this product, write to Sony Customer Information Service Center at 12451 Gateway Blvd., Ft. Myers, FL 33913, USA, or visit Sony Customer Service on the Sony Online Support Web site at <http://www.sony.com/pcsupport>.

Declaration of Conformity

Trade Name:	SONY
Model No.:	PCV-A11L
Responsible Party:	Sony Electronics Inc.
Address:	16450 W. Bernardo Drive San Diego, CA 92127 USA
Telephone:	858-942-2230

This phone number is for FCC-related matters only.

This device complies with Part 15 of the FCC rules. Operation is subject to the following two conditions:

- (1) This device may not cause harmful interference, and
- (2) this device must accept any interference received, including interference that may cause undesired operation.

Model No.: PCVA-IMB5A (For models equipped with Giga Pocket features)

This device complies with Part 15 of the FCC rules. Operation is subject to the following two conditions:

- (1) This device may not cause harmful interference, and
- (2) this device must accept any interference received, including interference that may cause undesired operation.

This equipment has been tested and found to comply with the limits for a Class B digital device, pursuant to Part 15 of the FCC Rules. These limits are designed to provide reasonable protection against harmful interference in a residential installation. This equipment generates, uses, and can radiate radio frequency energy and, if not installed and used in accordance with the instructions, may cause harmful interference to radio communications. However, there is no guarantee that interference will not occur in a particular installation. If this equipment does cause harmful interference to radio or television reception, which can be determined by turning the equipment off and on, the user is encouraged to try to correct the interference by one or more of the following measures:

- Reorient or relocate the receiving antenna.
- Increase the separation between the equipment and the receiver.
- Connect the equipment into an outlet on a circuit different from that to which the receiver is connected.
- Consult the dealer or an experienced radio/TV technician for help.

You are cautioned that any changes or modifications not expressly approved in this manual could void your authority to operate this equipment.

Only peripherals (computer input/output devices, terminals, printers, etc.) that comply with FCC Class B limits may be attached to this computer product. Operation with noncompliant peripherals is likely to result in interference to radio and television reception.

All cables used to connect peripherals must be shielded and grounded. Operation with cables, connected to peripherals, that are not shielded and grounded, may result in interference to radio and television reception.

FCC Part 68

This equipment complies with Part 68 of the FCC rules and the requirements adopted by the ACTA. On the modem card is a label that contains, among other information, a product identifier in the format US:AAAEQ##TXXXX. If requested, this number must be provided to the telephone company.

This modem uses the USOC RJ-11 telephone jack.

A telephone plug and jack used to connect this equipment to the premises wiring and telephone network must comply with the applicable FCC Part 68 rules and requirements adopted by the ACTA. The REN is used to determine the quantity of devices which may be connected to the telephone line.

Excessive RENs on the telephone line may result in the devices not ringing in response to an incoming call. In most, but not all areas, the sum of the RENs should not exceed five (5.0). To be certain of the number of devices that may be connected to the line, as determined by the total RENs, contact the telephone company. For products approved after July 23, 2001, the REN for this product is part of the product identifier that has the format US:AAAEQ##TXXXX. The digits represented by ## are the REN without a decimal point (e.g. 03 is a REN of 0.3). For earlier products, the REN is separately shown on the label.

If this equipment causes harm to the telephone network, the telephone company will notify you in advance that temporary discontinuance of service may be required. But if advance notice is not practical, the telephone company will notify the customer as soon as possible. Also, you will be advised of your right to file a complaint with the FCC if you believe it is necessary.

The telephone company may make changes in its facilities, equipment, operations or procedures that could affect the operations of the equipment. If this happens, the telephone company will provide advance notice in order for you to make the necessary modifications in order to maintain uninterrupted service.

If trouble is experienced with this equipment, for repair or warranty information, please contact the Sony Customer Information Service Center at 1-888-4-SONY-PC (1-888-476-6972), or write to the Sony Customer Information Center, 12451 Gateway Blvd., Fort Myers, FL 33913, USA, or find Sony Customer Service on the Web at <http://www.sony.com/pcsupport>. If this equipment is causing harm to the telephone network, the telephone company may request that you disconnect the equipment from the network until the problem is resolved.

Repair of this equipment should be made only by a Sony Service Center or Sony authorized agent. For the Sony Service Center nearest you, call 1-888-4-SONY-PC (1-888-476-6972), or visit the Sony Online Support Web site at <http://www.sony.com/pcsupport>.

Connection to Party Line Service is subject to state tariffs. Contact the state public utility commission, public service commission, or corporation commission for information.

If your home has specially wired alarm equipment connected to the telephone line, ensure the installation of this equipment does not disable your alarm equipment. If you have questions about what will disable alarm equipment, consult your telephone company or a qualified installer.

Please use a surge arrester against electrical surges.

Telephone Consumer Protection Act of 1991 (United States)

The Telephone Consumer Protection Act of 1991 makes it unlawful for any person to use a computer or other electronic device, including FAX machines, to send any message unless such message clearly contains, in a margin at the top or bottom of each transmitted page or on the first page of the transmission, the date and time it is sent and an identification of the business, other entity, or individual sending the message, and the telephone number of the sending machine or such business, other entity, or individual. (The telephone number provided may not be a 900 number or any other number for which charges exceed local or long distance transmission charges.)

In order to program this information into your facsimile machine, see your fax software documentation.

Telephone Consumer Guidelines (Canada)

Please refer to your telephone directory under 'Privacy Issues' and/or 'Terms of Service.' For more detailed information, please contact:

CRTC

**Terrasses de la Chaudière
Tour centrale 1 promenade du Portage
5 étage Hull PQ K1A 0N2.**

This Class B digital apparatus complies with Canadian ICES-003.

Cet appareil numérique de la classe B est conforme à la norme NMB-003 du Canada.

Model No.: PCVA-IMB5A (For models equipped with Giga Pocket features)

Supplementary Television Broadcasting Receiving Apparatus - Appareils supplémentaires de réception de télévision, Canada.

Industry Canada Notice

This equipment meets the applicable Industry Canada technical specifications.

The Ringer Equivalence Number (REN) is an indication of the maximum number of devices allowed to be connected to a telephone interface. The termination on an interface may consist of any combination of devices subject only to the requirement that the sum of the RENs of all the devices does not exceed 5.

Avis de L'Industrie Canada

Le présent matériel est conforme aux spécifications techniques applicables d'Industrie Canada.

L'indice d'équivalence de la sonnerie (IES) sert à indiquer le nombre maximal de terminaux qui peuvent être raccordés à une interface téléphonique. La terminaison d'une interface peut consister en une combinaison quelconque de dispositifs, à la seule condition que la somme d'indices d'équivalence de la sonnerie de tous les dispositifs n'exécède pas 5.

Macrovision license

This product incorporates copyright protection technology that is protected by U.S. patents and other intellectual property rights. Use of this copyright protection technology must be authorized by Macrovision, and is intended for home and other limited viewing uses only unless otherwise authorized by Macrovision. Reverse engineering or disassembly is prohibited.

Licence Macrovision

Ce produit intègre une technologie de protection de la loi sur les droits de propriété intellectuelle couverts par la législation américaine. L'utilisation de cette technologie doit être autorisée par Macrovision. Elle est uniquement destinée à un usage privé et à d'autres fins de visualisation limitée, sauf autorisation contraire de la part de Macrovision. Tout désosage ou désassemblage est formellement interdit.

Disposal of Lithium Battery

You can return your unwanted lithium batteries to your nearest Sony Service Center or Factory Service Center.



In some areas the disposal of lithium batteries in household or business trash may be prohibited.

For the Sony Service Center nearest you, call 1-888-476-6972 in the United States or 1-800-961-7669 in Canada.



Do not handle damaged or leaking lithium batteries. In some areas, the disposal of lithium batteries in household or business trash may be prohibited.

Danger of explosion if battery is incorrectly replaced. Replace only with the same or equivalent type recommended by the manufacturer. Discard used batteries according to the manufacturer's instructions.

The battery pack used in this device may present a fire or chemical burn hazard if mistreated. Do not disassemble, heat above 212° F (100° C), or incinerate. Dispose of used battery promptly. Keep away from children.



Ne pas manipuler les batteries au lithium qui fuient ou sont endommagées.

Une batterie non conforme présente un danger d'explosion. La remplacer seulement par une batterie identique ou de type équivalent recommandé par le fabricant. Évacuer les batteries usées selon les directives du fabricant.

La manutention incorrecte du module de batterie de cet appareil présente un risque d'incendie ou de brûlures chimiques. Ne pas démonter, incinérer ou exposer à une température de plus de 100°C. Évacuer promptement la batterie usée. Garder hors de portée des enfants.

Contents

Getting Started	13
Unpacking Your Computer	14
Locating Controls And Ports	17
About the Front Panel	18
About the Back Panel	22
About the Sub-woofer	25
About the Keyboard	26
About the Remote Control	29
Setting Up Your Computer	33
Connecting a Display (Monitor)	34
Connecting the Speakers	35
Connecting 5.1 (6-Channel) Speaker Systems	38
Configuring Software for Your Speaker System	39
Connecting the Keyboard and Mouse	42
Connecting the Telephone and Modem	43
Connecting the Power Cords	45
Turning On Your Computer	46
Registering Your Computer	46
Turning Off Your Computer	47

Setting Up Media Center.....49

- Getting Started with Media Center 50
- Setting Up TV Connections 51
- Connecting the Remote Sensor and
Remote Sensor Control(s)..... 57
- Connecting Other Devices 60
- Starting Media Center Software 63

Troubleshooting.....65

Support Options.....67

- Immediate Help and Support 67
- Resources for Additional Help and Support 69

Getting Started

Congratulations on your purchase of the Sony VAIO® computer! Your new, high-performance, multimedia computer combines state-of-the-art computer functionality with the latest audio, video and information technology features.

Unpacking Your Computer

Your computer may not be supplied with all of the accessories shown, depending on the computer configuration purchased. For details on the accessories supplied with your computer, see the online *Specifications* sheet.

 Your VAIO® computer is not supplied with System or Application Recovery CDs. Use the VAIO Recovery Wizard utility to recover your computer's operating system and preinstalled software.

Computer and supplied accessories

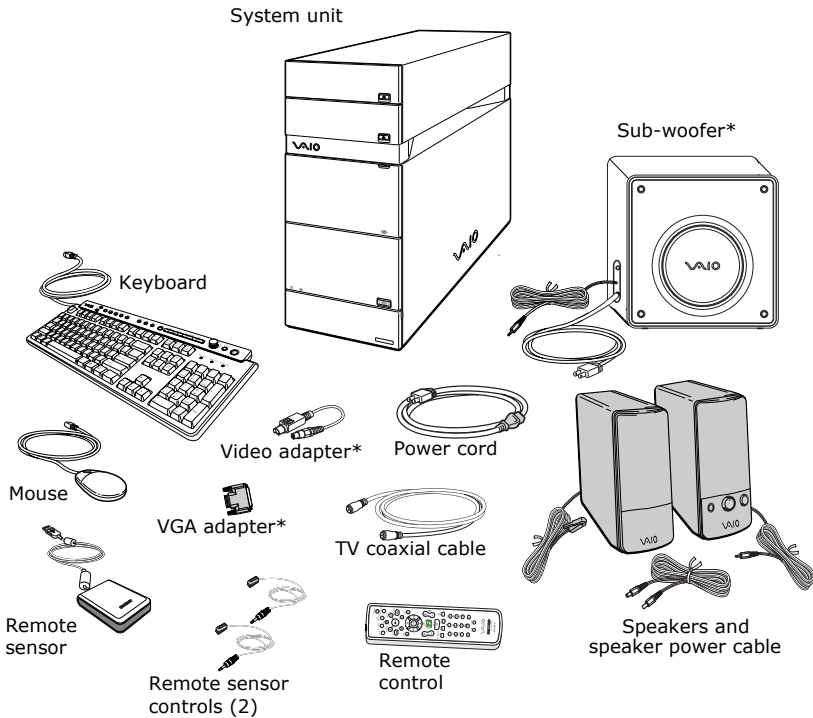

*This accessory is only available with certain computer models.

Manuals

- ❑ **VAIO® Computer Quick Start** — Provides basic information on setting up and registering your computer. The Quick Start also provides resources for technical support, safety guidelines and owner information.
- ❑ **About RAID Systems** — Contains an overview of RAID-0 and RAID-1 levels, along with basic information about RAID configuration. This guide is available only with configure-to-order (CTO) computers that are shipped as RAID-0 or RAID-ready systems.

Online Documentation

- ❑ **VAIO® Computer User Guide** — Describes features and specifications for your computer. It also includes information on the software programs included with your computer, and solving common problems.

To access the online User Guide:

- 1 Click **Start** in the Windows taskbar, then click **Help and Support**.
- 2 From the **VAIO Help and Support Center** menu, click **VAIO User Guide**.

- ❑ **Media Center User Guide** — Provides instructions and helpful information on using the Microsoft® Windows® XP Media Center software features.

To access the Media Center User Guide:

- 1 Click **Start** in the Windows taskbar, then click **Help and Support**.
- 2 From the **VAIO Help and Support Center** menu, click **Media Center User Guide**.

- ❑ **Specifications** — The online specifications sheet describes the hardware and software configuration of your VAIO computer.

To view the online specifications sheet:

- 1 Connect to the Internet.
- 2 Go to the Sony online support Web site at <http://www.sony.com/pcsupport>.
- 3 Click the **Documentation** link and follow the on-screen instructions to locate your model's specifications sheet.

- ❑ **VAIO Software** — Provides specific information on certain preinstalled software on your computer.

To access this online software information:

- 1 Click **Start** in the Windows® taskbar.
- 2 Click **Welcome to VAIO life**.

Hard Disk Drive Recovery

Your computer is equipped with the VAIO Recovery Wizard utility program that recovers your computer's operating system and preinstalled software.

For online information about hard disk drive recovery:

- 1 Click **Start** in the Windows® taskbar, then click **Help and Support**.
- 2 From the **VAIO Help And Support Center**, click **VAIO Recovery Options**.

 You can create a VAIO Recovery Media Kit using CD-R, single layer DVD+R, or single layer DVD-R media on VAIO computers equipped with the appropriate optical drive (a CD-RW, DVD-RW, or DVD±RW drive).

DVD+RW, DVD-RW, double layer DVD+R, and double layer DVD-R media (when it becomes available) cannot be used to create a VAIO Recovery Media Kit.

Other

A software library, containing the Microsoft® software and Sony® end-user license agreements.

Locating Controls And Ports



This section is intended to familiarize you with the controls, ports and jacks on your computer and supplied accessories. Your computer may not be equipped with all of these hardware features or accessories. The location of the controls, ports, and jacks may vary from the illustrations shown in this section. To view the specific connection capabilities for your computer, see the online Specifications sheet.

About the Front Panel

The front panel of your VAIO® Computer enables access to drives, memory card readers, ports and jacks that enable you to connect compatible peripheral devices. Your computer may not be equipped with all of these hardware features or accessories. The location of the controls, ports, and jacks may vary from the illustrations shown in this section.

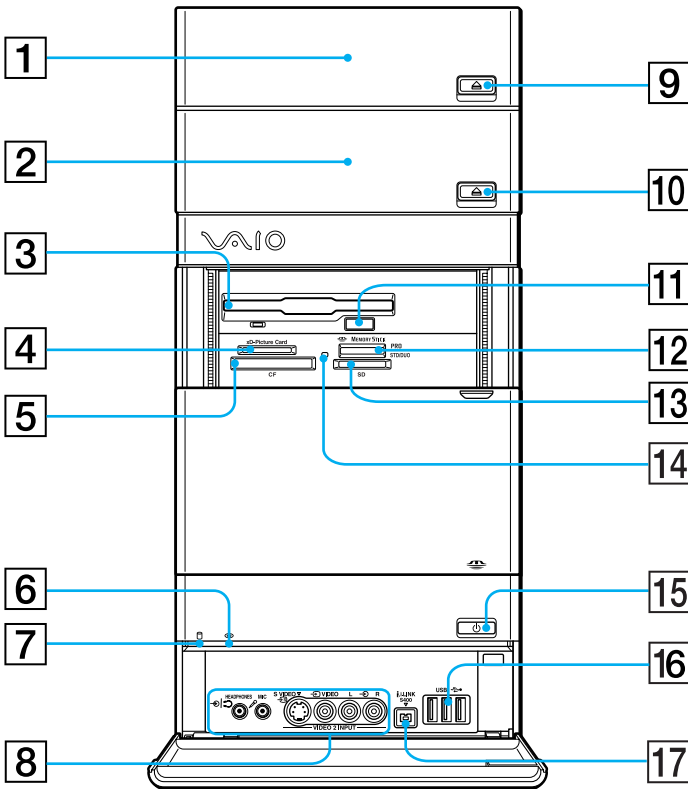
Front panel



-
- 1 Optical drive 1**
See the online *Specifications* sheet for optical drive information.
-
- 2 Optical drive 2**
See the online *Specifications* sheet for optical drive information.
-
- 3 Floppy disk drive**
Reads and writes data from and to a 3.5-inch floppy disk.
-
- 4 xD-Picture Card™ memory card reader**
Reads and writes data from and to xD-Picture Card media.
-
- 5 CompactFlash® and Microdrive™ memory card reader**
Reads and writes data from and to CompactFlash and Microdrive media.
-
- 6 Optical drive access indicator**
Light is amber while reading and writing data from and to the optical drives.
-
- 7 Hard disk drive access indicator**
Light is amber while reading and writing data from and to the hard disk.
-
- 8 Headphones/Line In jack**  | 
Connection for the supplied speakers, optional headphones, or audio device.
- Microphone jack** 
Connection for a microphone (optional).
- S-video In jack**
Connection for an S-video cable (optional).
- Composite video In jack**
Connection for a video cable (optional).
- Composite audio L In jack**
Connection for an audio cable (optional).
- Composite audio R In jack**
Connection for an audio cable (optional).
-
- 9 Optical drive 1 eject button**
Ejects a disc from Optical drive 1.
-

-
- 10 Optical drive 2 eject button**
Ejects a disc from Optical drive 2.
-
- 11 Floppy disk eject button**
Ejects a floppy disk from the floppy disk drive.
-
- 12 Memory Stick® memory card reader**
Reads and writes data from and to Memory Stick®, Memory Stick Pro™, and Memory Stick Duo™ media.
-
- 13 Secure Digital (SD)/MultiMediaCard™ (MMC) slot**
Reads and writes data from and to a Secure Digital (SD) or MultiMediaCard™ (MMC).
-
- 14 Media access indicator***
Light is amber when reading or writing data
-
- 15 Power button and power indicator**
Press the button to turn the computer on and off. The power indicator light is green when the computer is on and is amber when the computer is in Stand by mode. The power indicator is off when the computer is turned off.
-
- 16 Universal Serial Bus (USB 2.0) ports (3)**
Connections for compatible high/full/low-speed USB devices.
-
- 17 i.LINK (4-pin) S400 port (IEEE 1394)**
Connection for a compatible digital device.
-

* The media access indicator lights when reading or writing data with the Secure Digital (SD), Memory Stick®, xD-Picture Card™, or CompactFlash®/Microdrive™ slots.

 i.LINK is a trademark of Sony used only to designate that a product contains an IEEE 1394 connection. The i.LINK connection may vary, depending on the software programs, operating system, and compatible i.LINK devices. All products with an i.LINK connection may not communicate with each other.

Refer to the documentation that came with your compatible i.LINK device for information on operating conditions and proper connection. Before connecting compatible i.LINK devices to your computer, such as an optical or hard disk drive, confirm their operating system compatibility and required operating conditions.

To open and close the optical disc drive doors

Your computer is equipped with one or more optical disc drives that have a drive eject button located on the drive door.

- ❑ After pressing the eject button, wait for the drive to stop reading the CD. It may take a few moments for the drive tray to eject.
- ❑ Gently push the drive tray in, when closing the optical drive door. Do not force the door or handle roughly.
- ❑ After closing the drive door, wait a few moments for the drive to begin reading the CD.

To open the upper and lower front panel covers

The front of your computer is equipped with panels that cover drives, media card slots, jacks and ports. Do not force the panel covers or handle roughly.

Opening the front panel covers

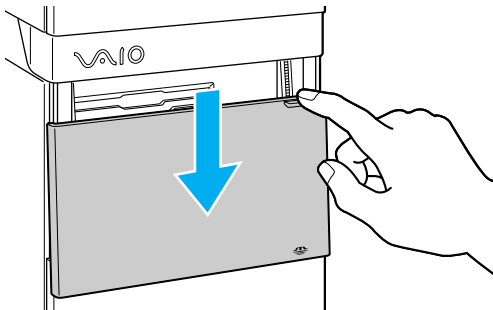

Slide the upper front panel cover down, using your fingertip.

Flip the lower front panel cover down, using your fingertip.

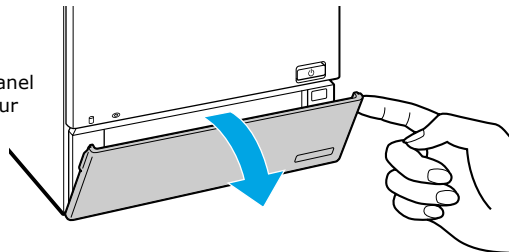



About the Back Panel

The back panel of your computer contains the ports for supplied and optional accessories. The icons on the back panel locate and identify the ports on your computer. The location of certain ports and jacks may vary from the illustration, based on the computer model purchased.

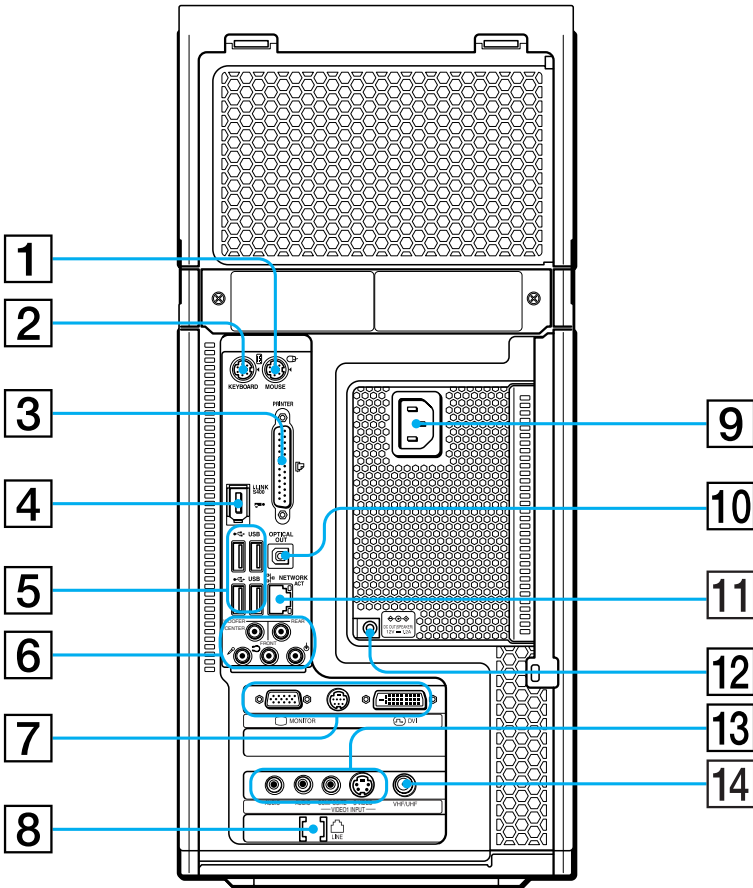
Back panel



-
- | | |
|-----------|---|
| 1 | Mouse port
Connection for a PS/2® mouse. |
| 2 | Keyboard port
Connection for a PS/2 keyboard. |
| 3 | Printer port
Connection for a parallel device, such as a printer or scanner. |
| 4 | i.LINK 6-pin S400 port (IEEE 1394)
Connection and power for a compatible digital device, such as a Sony Digital Handycam® camcorder. |
| 5 | Universal Serial Bus (USB 2.0) ports (4)
Connections for compatible high/full/low-speed USB devices. |
| 6 | Microphone jack 
Connection for a microphone (optional).
Front/Headphones jack 
Connection for the supplied speakers (2-channel), front speakers (5.1 channel speaker system*), or optional headphones.
Line In jack 
Connection for an audio device.
Woofers/Center jack [†]
Connection for a Sub-woofer [†] , control module, or center speaker (5.1 channel speaker system*)
Rear jack
Connection for rear speakers (5.1 channel speaker system*) |
| 7 | Monitor port ^{**}
Connection for standard (VGA) monitor.
TV Out (S-video/video) jack
Connection for an S-video cable.
DVI-D monitor port
Connection for a DVI monitor. |
| 8 | Modem line jack ^{††}
Connection for an RJ-11 telephone cable (optional). |
| 9 | AC Input port
Connection for the supplied power cord. |
| 10 | S/PDIF Optical Out port
Connection for a digital audio or optical device. |
-

11 Ethernet port

Connection for a 10BASE-T/100BASE-TX/1000BASE-T Ethernet.
(The port marked with  (Network) is for LAN connections only.)

12 Speaker DC Out jack

Connection for the speaker power cable (supplied 2-channel speakers).

13 Composite audio R In jack

Connection for an audio cable (optional).

Composite audio L In jack

Connection for an audio cable (optional).

Composite video In jack

Connection for a video cable (optional).

S-video In jack

Connection for an S-video cable (optional)

14 VHF/UHF port

Connection for a TV coaxial cable (supplied).

* Certain VAIO® computers that are configured to order (CTO), may supply 5.1 channel speakers as part of the accessory package. See your computer's specifications sheet for details on supplied accessories.

† Speaker system connections vary by model and manufacturer. See the information supplied with your speaker system for setup details.

‡ A sub-woofer is available with certain VAIO computer models. See your computer's specification sheet for details about supplied accessories.

** Certain VAIO® computers that are configured to order (CTO), may have a DVI-D monitor port installed in this location. See your computer's specifications sheet for hardware configuration details

†† An optional "1-to-2" jack adapter device (splitter) is required to connect both a telephone and modem line to your computer.

About the Sub-woofer

Certain VAIO® computers are supplied with a sub-woofer unit to enhance your computer's sound capability. The sub-woofer is compatible with the speakers supplied with your VAIO computer. See the section, "Connecting the Speakers" on page 35, for instructions. For information about supplied accessories, see your computer's online specifications sheet. Go to the Sony online support Web site at <http://www.sony.com/pcsupport>.

Sub-woofer unit

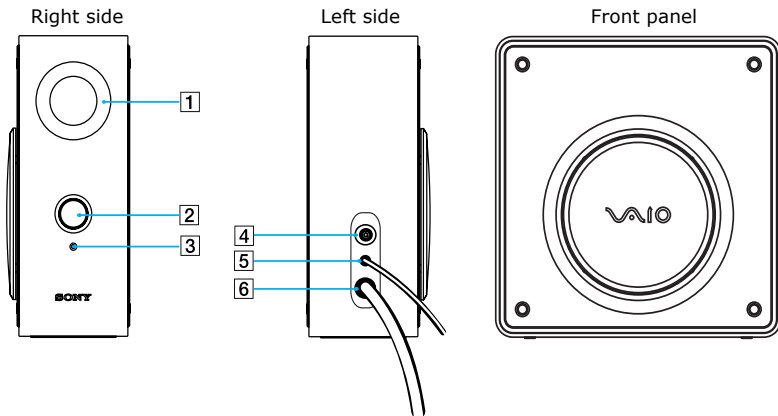

- 1 Port**
The port extends the low frequency response to extend the volume output of the sub-woofer unit.
- 2 Power knob/volume control**
Rotate the knob clockwise to turn on the sub-woofer unit. Control the volume by rotating the knob until the desired volume is reached.
- 3 Power indicator**
Light is green while the power is on.
- 4 Speaker jack**
Connection for the speaker cable.
- 5 Sub-woofer unit cable**
Connects the sub-woofer unit to the computer's Headphones jack.
- 6 AC power cord**
Connects the sub-woofer unit to a grounded AC wall outlet or power strip.

About the Keyboard

This section describes the special and standard functions available for your keyboard.

VAIO keyboard with Media Center features

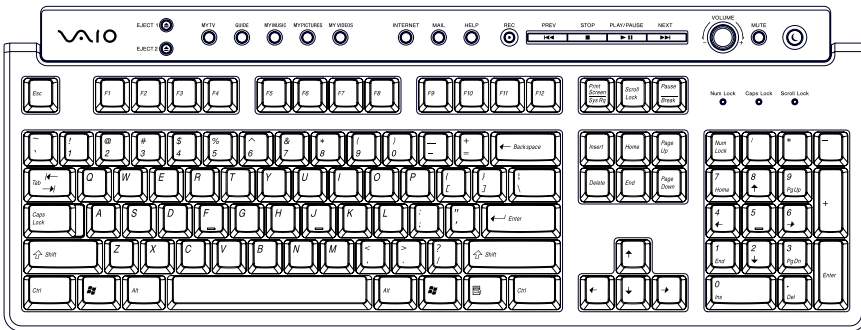

The VAIO® keyboard supplied with your computer has a standard key arrangement with additional keys and controls that support Microsoft® Windows® XP Media Center Edition features.

VAIO keyboard



BUTTON	DESCRIPTION
EJECT 1	Opens and closes the optical drive 1 tray.
EJECT 2	Opens and closes the optical drive 2 tray.
MY TV	Opens the My TV window of Windows® Media Center.
GUIDE	Opens the TV program guide of Media Center.
MY MUSIC	Opens the My Music window of Media Center.
MY PICTURES	Opens the My Pictures window of Media Center.

BUTTON	DESCRIPTION
MY VIDEOS	Opens the My Videos window of Media Center.
INTERNET	Starts the assigned Internet browser.
MAIL	Starts the e-mail software program.
HELP	Starts the Media Center Help , if Media Center software is running. (If Media Center software is not running, the Help and Support Center is started.)
REC	Records TV programs.
PREV	Press once to return to the beginning of the DVD chapter, video track, or audio track. Press twice to return to the previous DVD chapter, video track, or audio track.
STOP	Stops media recording or playback.
PLAY/PAUSE	Pauses the movie, video, slide show, or audio track. Press again to resume playback.
NEXT	Advances to the next DVD chapter, video track, or audio track.
VOLUME knob	Increases (+) and decreases (-) the volume as you turn the knob.
MUTE	Turns the sound off. Press again to restore sound.
STANDBY	Places the computer in Stand by mode to reduce power consumption. Press any key briefly to resume normal operation.

KEY	DESCRIPTION
Function	The 12 function keys along the top of the keyboard are used to perform certain tasks. The task associated with each function key may vary between software programs.
Numeric keypad	Use the numeric keypad area to type numbers or to perform basic math calculations. Press the Num Lock key to activate the numeric keypad. (The Num Lock indicator lights.) Press the Num Lock key again to deactivate the numeric keypad.
Directional Arrows	The up, down, left, and right arrow keys move the pointer on the screen.
Applications 	The Applications key displays a shortcut menu in certain software programs. Pressing this key is equivalent to clicking the right mouse button.
Windows 	The key with the Microsoft® Windows® logo, displays the Start menu. Pressing this key is equivalent to clicking Start on the taskbar.
INDICATORS	FUNCTION
Num Lock	The Num Lock indicator lights when the numeric keypad is activated. When the indicator is off, the directional arrow and correction keys on the numeric keypad area are active.
Caps Lock	The Caps Lock indicator lights to advise you that the keyboard is set to type letters in uppercase. When the indicator is off, the letters appear in lower case as you type.
Scroll Lock	The Scroll Lock indicator lights to advise you that your screen's scrolling pattern has changed. When the indicator is off, the screen scrolls normally. This function is not available with all software programs.



About the Remote Control

The Media Center remote control is supplied with VAIO Digital Studio® computers that are equipped with the Microsoft® Windows® XP Media Center Edition operating system. The remote control can start and stop video recording and playback, select channels, and set viewing preferences. This section describes the basic functions of your remote control.

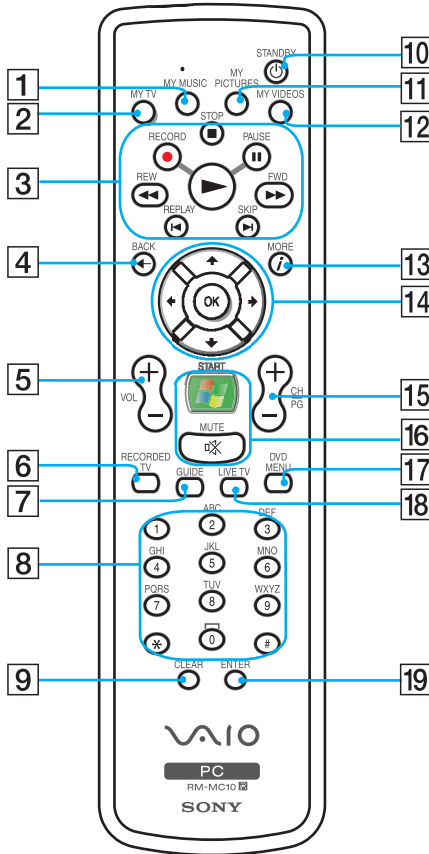
Remote Control



-
- 1 MY MUSIC button**
Press to view and listen to your music playlists.
-
- 2 MY TV button**
Press to view the My TV menu.
-
- 3 STOP button**
Press to stop media playback or TV recording session.
PAUSE button
Press to pause media playback. Press again to resume playback.
FWD button
Press to fast-forward media at three speeds.
SKIP button
Press to move media forward, for example, one audio track, one DVD chapter, and 30 seconds of recorded TV or video.
REPLAY button
Press to move media backward, for example, one audio track, one DVD chapter, and seven seconds of TV or video.
REW button
Press to move media backward at two speeds.
RECORD button
Press to begin recording.
PLAY button ►
Press to begin media playback.
-
- 4 BACK button**
Press to return to the previous window.
-
- 5 VOL button**
Press to increase (+) or decrease (-) the volume.
-
- 6 RECORDED TV button**
Press to view previously recorded TV programs (In **My TV** window)
-
- 7 GUIDE button**
Press to view the TV program guide for your area.
-
- 8 Channel number buttons (0-9)**
Press to select specific channels or enter text.
(Press **Enter** or **OK** to activate the channel selection.)
-
- 9 CLEAR button**
Use to backspace and delete entered text.
-

-
- 10 STANDBY button**
Press to place the computer in Stand by mode to reduce power consumption.
-
- 11 MY PICTURES button**
Press to view pictures or a slide show.
-
- 12 MY VIDEOS button**
Press to view videos from your video collection.
-
- 13 MORE button **
Press to view additional options that are available for Media Center features.
-
- 14 Directional arrow buttons**
Press the Up, Down, Left, and Right arrow buttons to move the pointer on the screen.
- OK button**
Press **OK** to select the desired action or window option. If watching full-screen TV press **OK** to return to the previous channel. Press **OK** again to switch between channels.
-
- 15 CH/PG (Channel/Page) button**
Press to change or page up/down channels (no number input required).
-
- 16 START  button**
Press to open the Media Center Start menu.
- MUTE button**
Press to turn off the sound. Press again to restore the sound.
-
- 17 DVD MENU button**
Press to open the main menu on a DVD.
-
- 18 LIVE TV button**
Press to view TV programming.
-
- 19 ENTER button**
Press to activate feature or action, such as channel selection or return to previous channel. (This button's actions are similar to using the OK button.)
-

Setting up the remote control

- 1 Turn the remote control over.
- 2 Press in the tab and lift the battery cover up.
- 3 Insert two AA batteries (supplied) into the remote control as shown.
- 4 Align the battery cover to the remote control.
- 5 Press down until the cover clicks into place.

Inserting batteries into the remote control

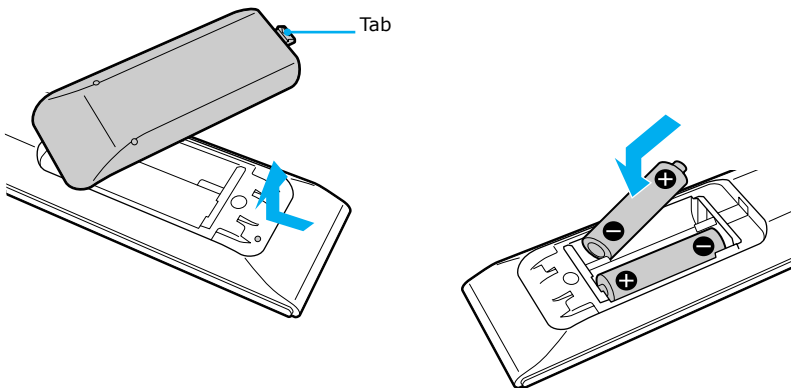

 If your remote control does not operate properly, you may need to replace the batteries. When your remote control is not being used for extended periods of time, remove the batteries to avoid possible damage from battery leakage.

Setting Up Your Computer

Your computer may not be equipped with all of the hardware features described in the section. The location of the controls, ports, and jacks may vary from the illustrations shown. See the online Specifications sheet for your computer's specific hardware configuration.

Connecting a Display (Monitor)

- 1 Plug the display's cable into the appropriate monitor port.
- 2 If necessary, plug the display's cable into the rear of the display.

To connect a display

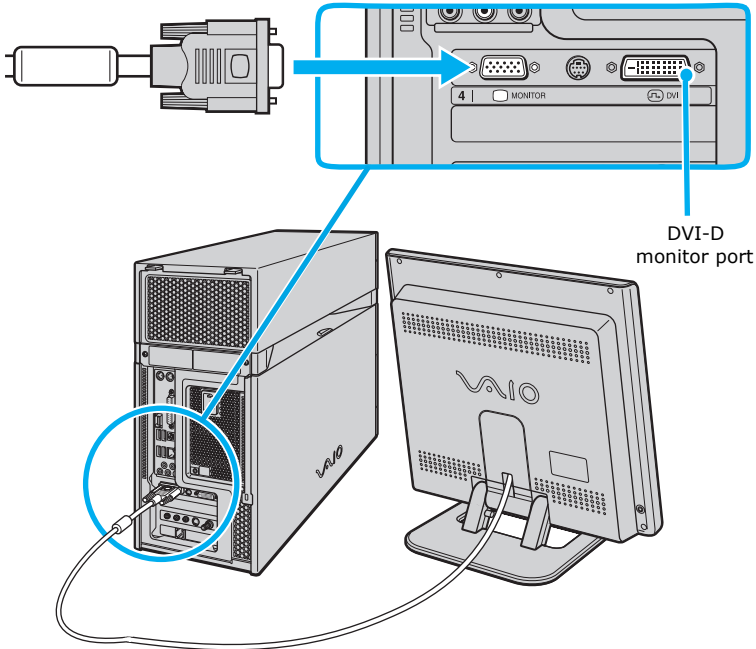

To connect a DVI display with the DVI-D monitor port*

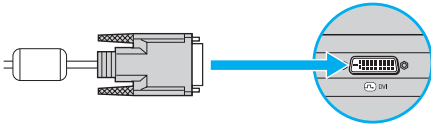

*A Video adapter device is required to connect a VGA monitor using the DVI-D port.

 Install your equipment so that you can easily reach the power outlet in the event of an emergency.

Connecting the Speakers

Your VAIO® computer is supplied with 2-channel speakers. Certain models are supplied with a sub-woofer unit or 5.1 channel speaker systems*.

To connect the 2-channel speakers (supplied)

- 1 Plug the cable attached to the back of the left speaker into the Speaker(L) jack on the back of the right speaker.

To connect the computer and speakers

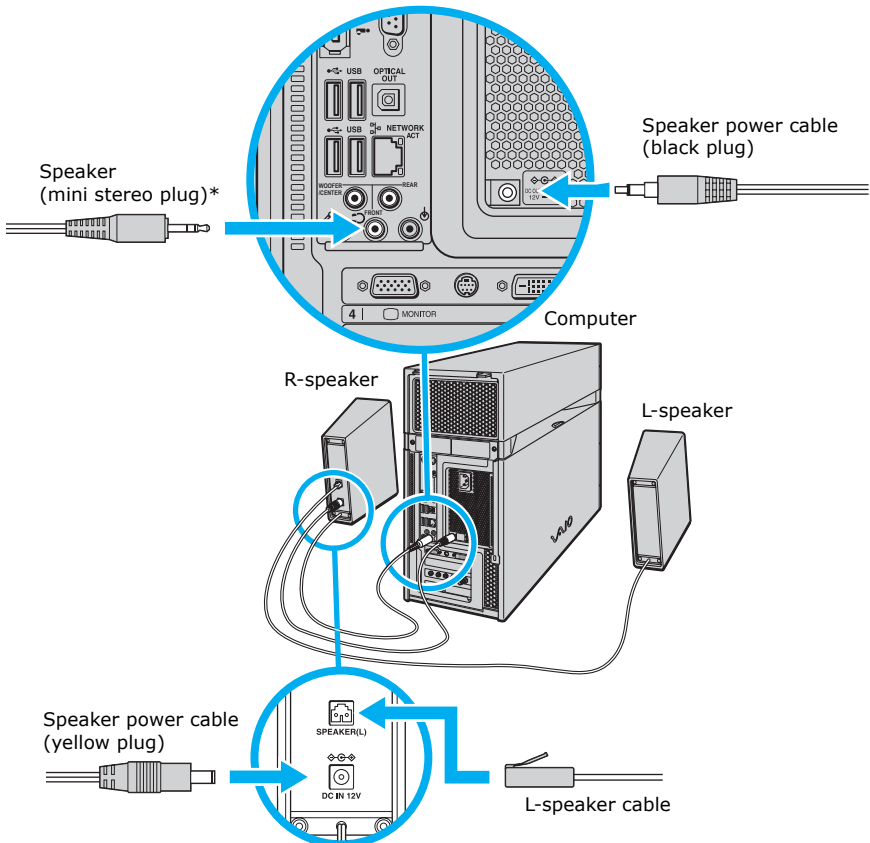

* Certain VAIO computers that are configured-to-order (CTO), may be supplied with a 5.1 channel speaker system. For details about using this type of speaker system, see the information provided with the system.

- 2 Insert the yellow plug of the speaker power cable into the DC In jack on the back of the right speaker.
- 3 Insert the black plug of the speaker power cable into the DC Out jack located on the back panel of your computer.
- 4 Insert the mini stereo plug of the cable that is attached to the right speaker, into the Front/Headphones jack, located on the back panel of your computer.

 You can also plug the right speaker's mini stereo plug into the headphones jack located on the lower front panel of your computer.

To connect a sub-woofer unit

Certain VAIO® computer models are supplied with a sub-woofer unit which requires a different setup.

- 1 Insert the mini stereo plug of the cable that is attached to the right speaker into the speaker jack, located on the left side of the sub-woofer unit.

To connect the speakers and sub-woofer unit

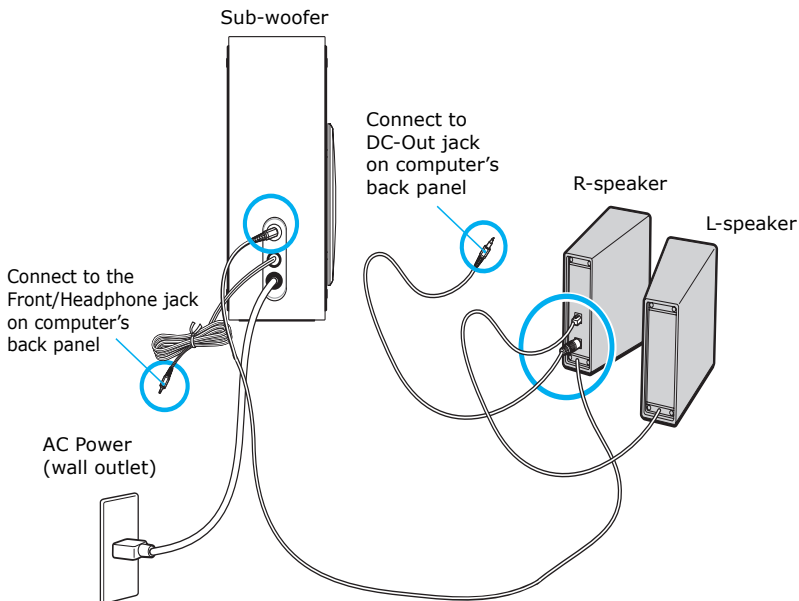

- 2 Insert the mini stereo plug from the sub-woofer unit's cable into the Headphones jack, located on the back panel of your computer.

 You can also plug the sub-woofer's mini stereo plug into the headphones jack located on the lower front panel of your computer.

- 3 Plug the sub-woofer unit's power cord into a grounded AC wall outlet or power strip.

To connect the sub-woofer to the computer

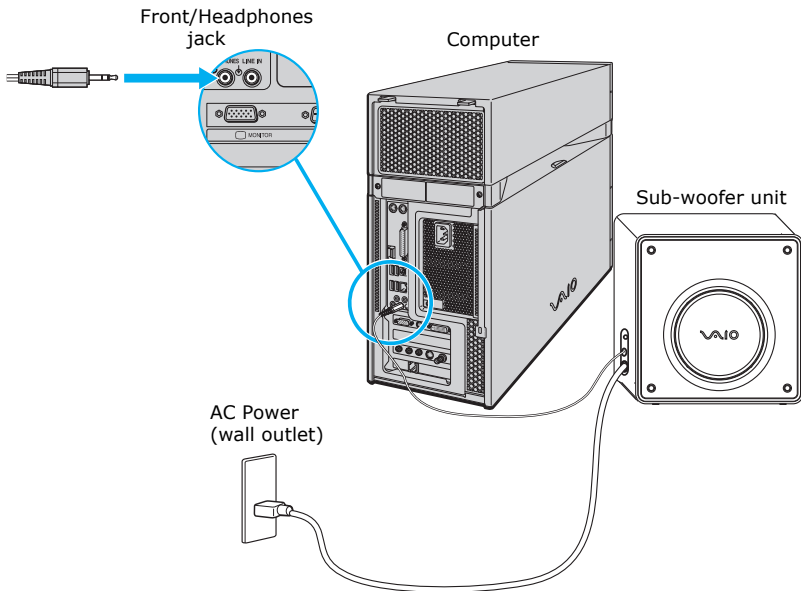

Connecting 5.1 (6-Channel) Speaker Systems

Certain VAIO® computers that are configured-to-order (CTO), are supplied with a 5.1 channel speaker system, or you may wish to use your own 5.1 (6-channel) speaker system.

To set up the speakers with your computer:

- ❑ Match the color of the mini stereo plugs (speaker system) to the color of the speaker jacks on the back panel of your computer.
- ❑ Follow the connection instructions provided with your speaker system.

Audio jacks (computer back panel detail)

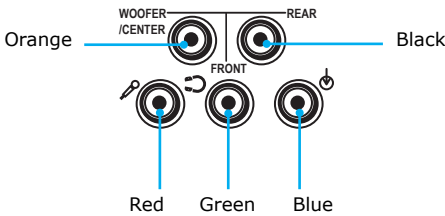

Jack color	Description/Connection
Orange	Woofers/Centers * — Connect a Sub-woofer†, control module, or Center speaker (5.1 channel speaker system‡)
Black	Rear — Connect rear speakers (5.1 channel speaker system).
Red	Microphone — Connection an optional microphone.
Green	Front/Headphones — Connect supplied speakers (2-channel), front speakers (5.1 channel speaker system), or optional headphones.
Blue	Line In — Connect an audio device.

* Speaker system connections vary by model and manufacturer. See the information supplied with your speaker system for setup details.

† A sub-woofer is available with certain VAIO® computer models. See your computer's specification sheet for details about supplied accessories.

‡ Certain VAIO computers that are configured to order (CTO) may supply a 5.1 channel speaker system as part of the accessory package. See your computer's specifications sheet for details on supplied accessories.

Configuring Software for Your Speaker System

When using 5.1 channel (digital or analog) speaker systems, certain software programs require setting changes to enable proper audio performance.

To configure RealTek® Sound Effect Manager software

For 6 channel-analog speakers

- 1 Click **Start** in the Windows® taskbar, and then click **Control Panel**.
- 2 Click **Sounds, Speech, and Audio Devices**, and then click **Sound Effect Manager**.

The **Sound Effect Manager** window appears.

- 3 Click **Speaker Configuration**.
- 4 From the drop-down menu on the left, select **6CH Speaker**.
- 5 Close the **Sound Effect Manager** window.

For 6 channel-digital speakers

- 1 Click **Start** in the Windows® taskbar, and then click **Control Panel**.
- 2 Click **Sounds, Speech, and Audio Devices**, and then click **Sound Effect Manager**.

The **Sound Effect Manager** window appears.

- 3 Click **Speaker Configuration**.
- 4 From the drop-down menu on the left, select **Dolby Digital 5.1**.
- 5 Close the **Sound Effect Manager** window.

To configure Media Center software

Your computer's factory default settings for audio can be changed using the Media Center Settings feature. You can switch between 2-channel, 6-channel, or S/PDIF output modes.

- 1 Use the Media Center remote control, your keyboard, or mouse, to start the Media Center software program.
- 2 Select **Settings** and press **OK**.
The **Settings** window appears.
- 3 From the **Settings** window, select **DVD**, and then press **OK**.
The **DVD Settings** window appears.
- 4 Select **Audio** and press **OK**.
InterVideo® software's audio settings window appears.
- 5 Select **Configuration** and press **OK**.
- 6 From the section, **Set sound output to match your system**, use +/- to locate the appropriate speaker system setup.
To enable S/PDIF output, select **SPDIF**.
- 7 Select **Save**, and press **OK**.
- 8 Press  on the remote control to return to the Media Center Start menu.

To configure WinDVD software

- 1 Click **Start** in the Windows® taskbar, and point to **All Programs**.
- 2 Point to **InterVideo WinDVD 5**, and then click on **InterVideo WinDVD 5 for VAIO**.
The **InterVideo WinDVD for VAIO** window opens.
- 3 Right-click in the **WinDVD** window.
A shortcut menu appears.
- 4 Click **Setup...**, to view the **Setup** dialog box.
- 5 Select the **Audio** tab.

- 6 From the section, **Audio Speaker Configuration**, select **6-channel speaker (5.1 Home Theater)** or the desired speaker configuration.

To enable S/PDIF, go to **Audio Output Configuration** and select **Digital (S/PDIF) out to External Processor**.

- 7 Click **Apply**, and then click **OK**.

 InterVideo® software automatically detects the speaker system setup. You may notice that some options are disabled.

Connecting the Keyboard and Mouse

- 1 Plug the keyboard cable into the keyboard port on the back of the computer.
- 2 Plug the mouse cable into the mouse port on the back of the computer.

To connect the keyboard and mouse

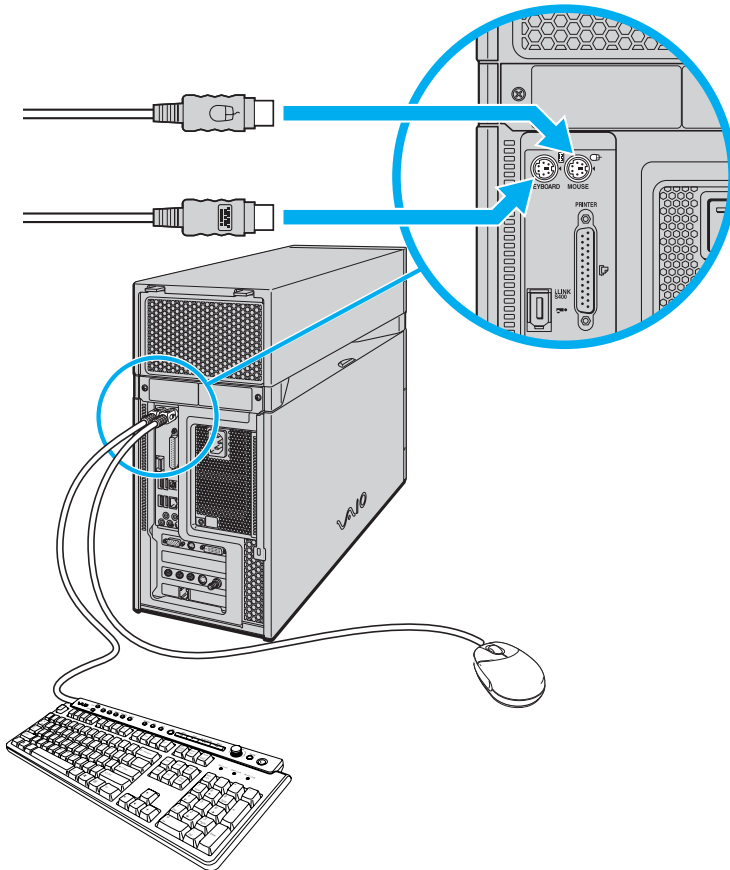

Connecting the Telephone and Modem

Your computer is equipped with a single modem line jack to connect your installed modem with your telephone wall jack.

To connect the modem

- 1 Unplug your telephone from the wall jack and set aside.
- 2 Plug another telephone cable (optional) into the modem line jack located on the back panel of your computer
- 3 Plug the other end of the cable into the wall jack.

To connect the telephone and modem

To use your wall jack for both telephone and modem lines, purchase an additional RJ-11 telephone cable and a “1-to-2” jack adapter device (splitter).

- 1 Unplug your telephone cable from the wall jack.

To connect the telephone and modem

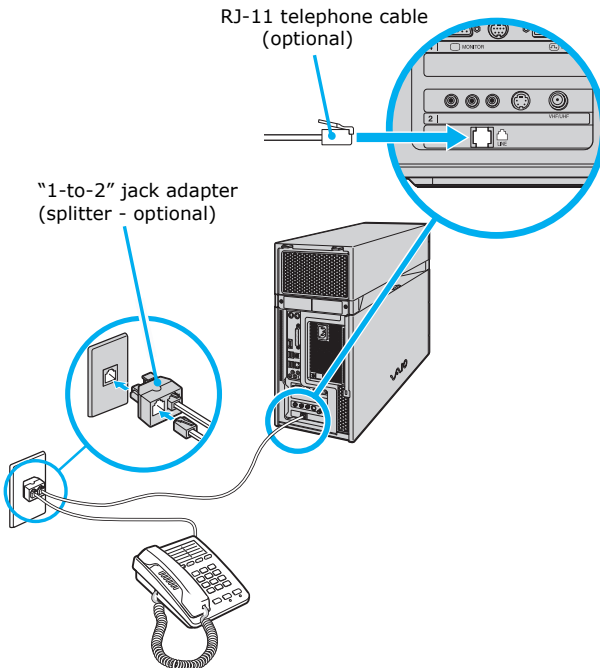

- 2 Insert the telephone's cable into one of the jacks on an optional "1-to-2" jack adapter device (splitter).
- 3 Insert one end of a second telephone cable (optional) into the other jack on the splitter device.
- 4 Insert the plug end of the splitter device into the wall jack.
- 5 Plug the second telephone cable into the modem line jack located on the back panel of the computer.



Your computer has a protective sticker  covering the Ethernet port located on the rear panel. Connect 10BASE-T, 100BASE-TX, or 1000BASE-T cables to the Ethernet port, depending on your computer's Ethernet port specification. Using incorrect cables or a telephone cable may result in an electric current overload that can cause a malfunction, excessive heat, or fire in the Ethernet port. For help on connecting to a network, see your network administrator.

Connecting the Power Cords

- 1 Plug the power cord into the back of the computer.
- 2 Plug both the display and computer power cords into a grounded AC wall outlet or a power strip.

To connect the power cords

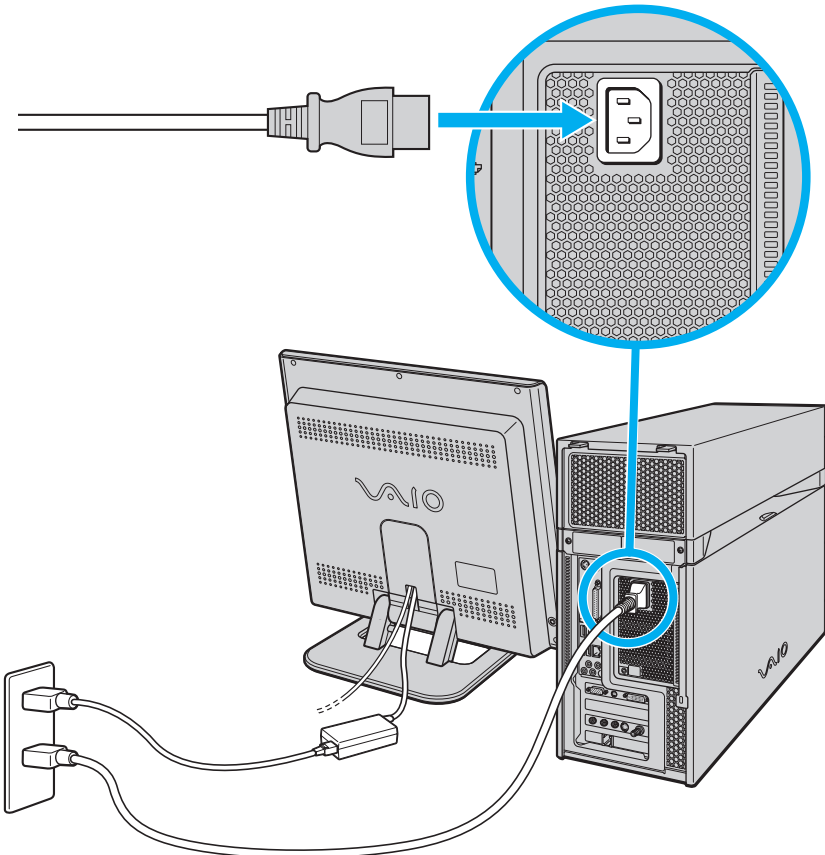

Turning On Your Computer

When you start your computer for the first time, your computer may detect new equipment and display a dialog box that prompts you to restart your computer. Respond to this prompt immediately.

 Before turning on your computer, set up the cables and connections required to use Microsoft® Windows® XP Media Center Edition features. See the section, “Setting Up Media Center” on page 49.

- 1 Press the power button on the computer to turn on the power.
- 2 Press the power button on the display to turn on the power.
- 3 Press the power button on the right speaker to turn on the power.

To turn on your computer

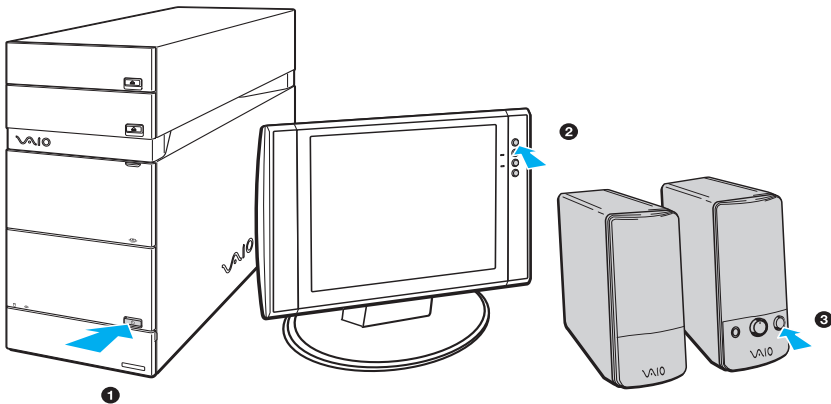

Registering Your Computer

Register your computer and take advantage of Sony's commitment to quality customer support.

About the benefits of registering with Sony

- Sony Customer Support** — Communicate with a Support Representative to troubleshoot problems you may be having with your computer.

- ❑ **Limited warranty** — Protect your investment. See the Limited Warranty Card for more details.

You are prompted to register your computer the first time you turn on the computer. Follow the on-screen instructions to complete the registration process. If you are not able to register your computer during the first session, you can register your computer online at the Sony VAIO PC Registration Web site. Go to <http://www.sony.com/vaioregistration>.

Turning Off Your Computer

Follow these steps when you are ready to turn off your computer for an extended period of time.



To avoid loss of data, do not use the Power button to turn off the computer.

To turn off your computer

- 1 Click **Start** in the Windows® taskbar, then select **Turn Off Computer**.
The **Turn Off Computer** dialog box appears.
- 2 Select the **Turn Off** option.

 Respond to any prompts about saving your documents.

- 3 Wait for your computer to turn off automatically—the power indicator light turns off.
- 4 Turn off any peripheral devices connected to your computer.

 If you plan to stop using your computer for a short period of time, use Stand by mode.

About the power button

If your computer stops responding, press and hold the Power button for more than six seconds to force your system to shut down. You may need to repeat this procedure if your computer does not shut down on the first attempt.

Setting Up Media Center

Your VAIIO Digital Studio® computer has the Microsoft® Windows® XP Media Center Edition operating system to enhance your computing experience. Media Center provides you with a wide range of TV, DVD, and video viewing, as well as music recording and playback. This section describes how to set up your TV, set-top box, and other equipment.

Getting Started with Media Center

There are several tasks to complete before you are ready to use Media Center features. After setting up your hardware connections, review this checklist before you begin using the Media Center software program, to enable full use of all the features.

- Set up your VAIO® Media Center computer, accessories, and peripheral equipment correctly. Follow the instructions in the section, “Setting Up Your Computer” on page 33.
- Establish an active Internet connection. For information on setting up a dial-up Internet connection, see “How do I set up a dial-up connection?” on page 66.
- Connect your computer to the TV signal source.
- Insert two AA batteries into the Media Center remote control.
- Plug the remote sensor unit into a USB port on your computer and place it in a location that enables direct communication with the remote control.
- Connect the remote sensor control between your cable or satellite set-top box, and the remote sensor unit.

 An Internet connection and TV signal source are not required to use some features, but Sony recommends using these options to fully experience Media Center.

To locate the online Media Center User Guide

You can find more information about using Microsoft® Windows® XP Media Center Edition software in the online Media Center User Guide.

- 1 Click **Start** in the Windows® taskbar, and then click **Help and Support**.
- 2 From the **VAIO Help and Support Center**, click **Media Center User Guide**.

Setting Up TV Connections

The best method of connecting your computer, TV monitor or display, and TV programming access, is determined by the type of cable service connection available in your home. Your computer's hardware configuration may vary from the illustrations shown in this section. See the online Specifications sheet for details about your computer's hardware configuration.

 Your VAI0 Digital Studio ® computer is supplied with certain video cables. Depending on your in-home cable access, you may require extra cables, adapters or connection equipment that are optional for your computer.

Connecting to standard cable access (CATV)

Option 1

- 1 Connect one end of the TV coaxial cable (supplied) to your cable service access.
- 2 Connect the other end of the TV coaxial cable to the VHF/UHF port on the back panel of your computer.

To connect in CATV mode (Option 1)

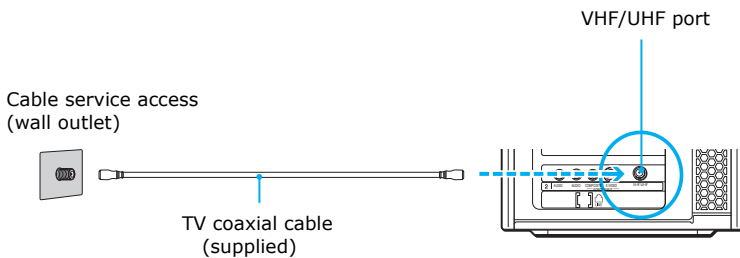

Option 2

- 1 Connect one end of a TV coaxial cable (optional) to your cable service access. Connect the other end to the single-connection side of a splitter adapter.

- 2 Connect the TV coaxial cable (supplied) to the double-connection side of the splitter adapter. Connect the other end to the VHF/UHF port on the back panel of your computer.
- 3 Connect a third TV coaxial cable (optional) to the double-connection side of the splitter adapter. Connect the other end to the VHF/UHF port on the back of your TV monitor or display.

To connect in CATV mode (Option 2)

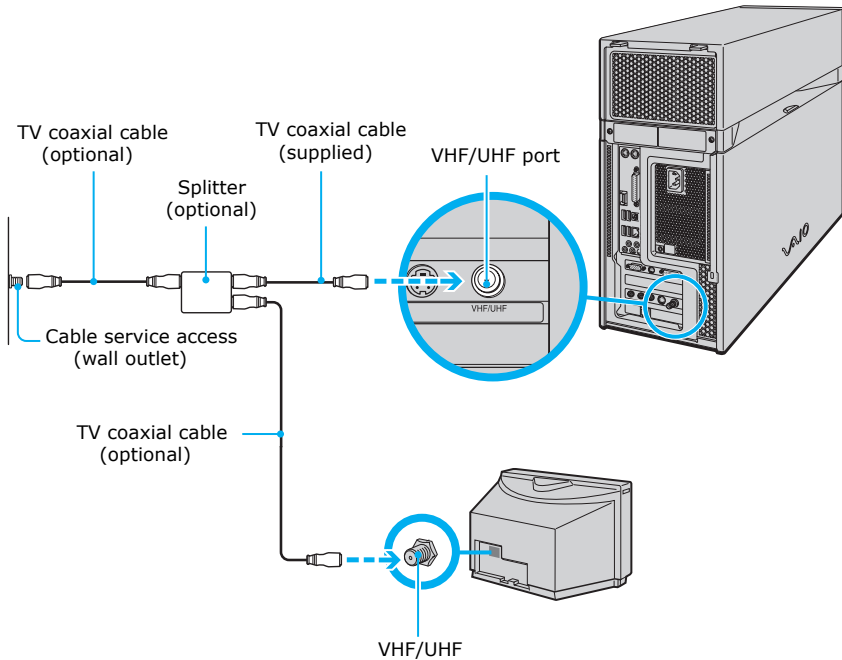

Connecting to a standard antenna (air) system

You can connect your computer to an indoor/outdoor antenna system, using Option 1 or 2 from the previous section, “Connecting to standard cable access (CATV)” on page 51. The antenna system in your home may require a VHF/UHF RF combiner/transformer (optional) to connect your computer and the indoor/outdoor antenna system.

 If you are connecting to an indoor/outdoor antenna system, you may need to reorient the antenna for better reception.

Option 1

- 1 Connect one end of a TV coaxial cable (optional) to your antenna outlet. Connect the other end to a VHF/UHF RF combiner/transformer (optional).
- 2 Connect the TV coaxial cable (supplied) from the combiner/transformer to the VHF/UHF port on the back panel of your computer.

To connect in standard antenna mode (air)

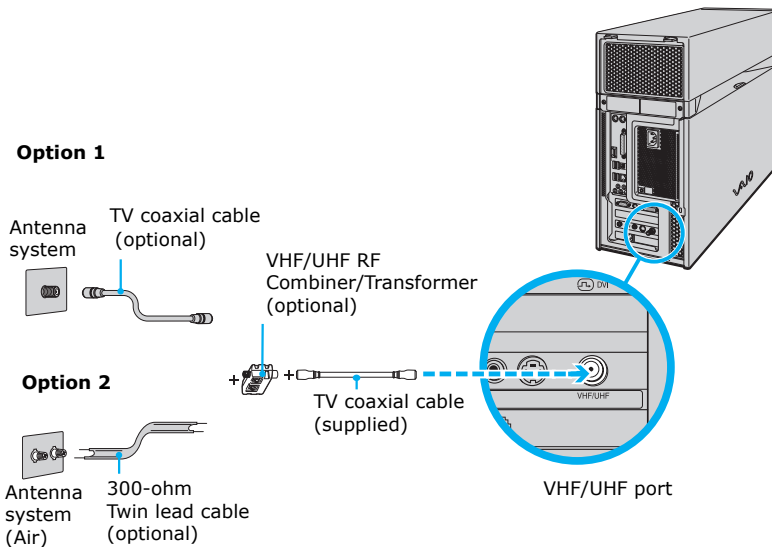

Option 2

- 1 Connect both ends of the antenna's twin lead cable to the screw-type grips on the combiner/transformer.
- 2 Connect the TV coaxial cable (supplied) from the combiner/transformer to the VHF/UHF port on the back panel of your computer.

 Your VAIO Digital Studio® computer is supplied with certain video cables. Depending on your in-home cable access, you may require extra cables, adapters or connection equipment not supplied with your computer.

Connecting a Cable or Satellite Set-top Box

You can connect your computer to cable or satellite service that requires a set-top box.

Option 1

- 1 Connect one end of a TV coaxial cable (optional) to your cable service access. Connect the other end to the In jack on the back panel of your set-top box.

To connect in set-top box mode (Option 1)

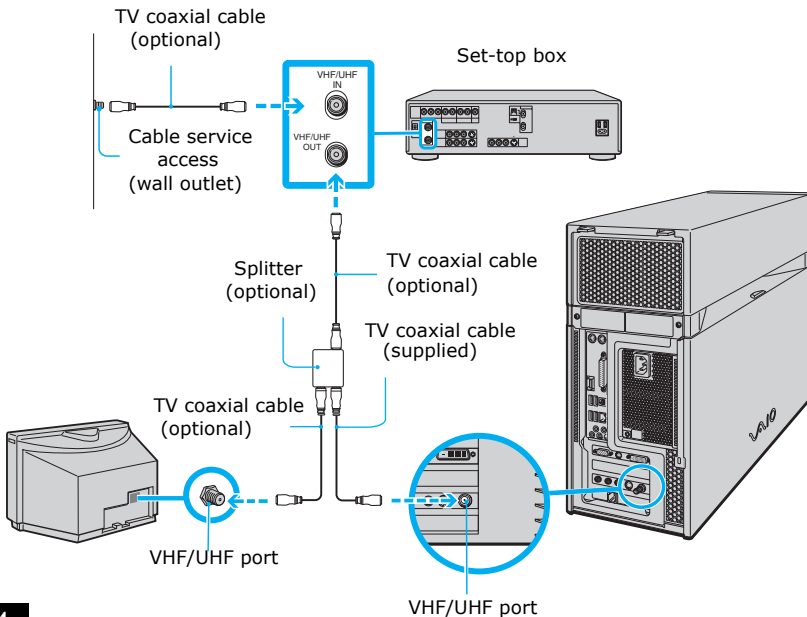

- 2 Connect a second TV coaxial cable (optional) to the Out jack on your set-top box. Connect the other end to the single-connection end of a splitter adapter (optional).
- 3 Connect a third TV coaxial cable (supplied) to the double-connection end of the splitter adapter. Connect the other end to the VHF/UHF port on the back panel of your computer.
- 4 Connect a fourth TV coaxial cable (optional) to the double-connection end of the splitter adapter. Connect the other end to the VHF/UHF port on the rear of your TV monitor or display.

Option 2

- 1 Connect one end of the TV coaxial cable (supplied) to your cable service access. Connect the other end to the In jack on the back panel of your set-top box.

To connect in set-top box mode (Option 2)

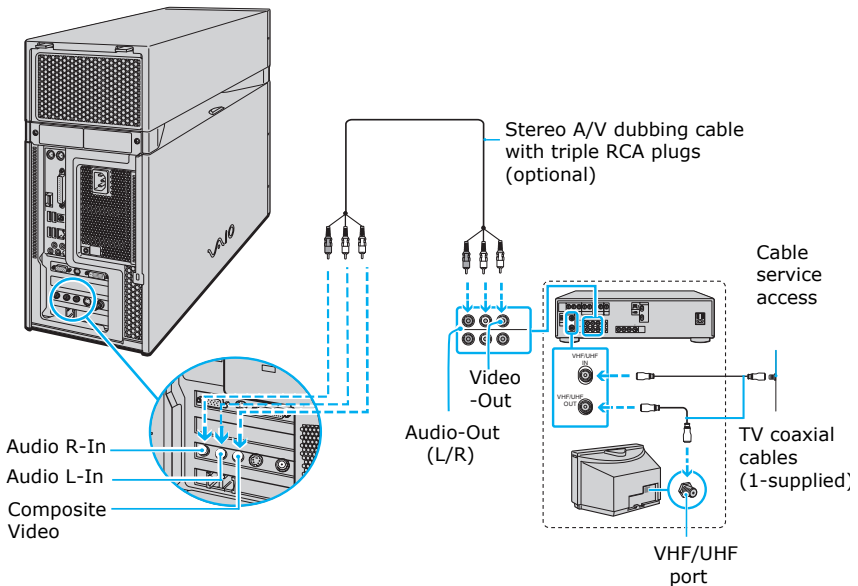

- 2 Connect a second TV coaxial cable (optional) to the Out jack on your set-top box. Connect the other end to the VHF/UHF port on the rear of your TV monitor or display.
- 3 Connect one end of a stereo A/V dubbing cable with triple RCA plugs (optional) to the Video Out and Audio-OUT (L/R) jacks on the back panel of your set-top box, matching the plug and jack colors.
- 4 Connect the other ends of the stereo A/V dubbing cable into the Audio-R (IN), Audio-L (IN), and Composite video (IN) jacks on the back panel of your computer, matching the plug and jack colors.

 You can connect your computer to a set-top box using an S-video cable (optional) and an audio cable (optional) instead of a stereo A/V dubbing cable (optional). See “Connecting Other Devices” on page 60.

Connecting the Remote Sensor and Remote Sensor Control(s)

The remote sensor communicates with the Media Center remote control, enabling you to change channels and to perform other functions. If you are using a cable or satellite set-top box, you can attach the remote sensor control* to operate the set-top box with the Media Center remote control.

To connect the remote sensor

- 1 Connect the remote sensor unit to a USB port located on either the front or back panel of your computer.
- 2 Position the remote sensor to enable unobstructed communication with your remote control.

Connecting the remote sensor (back panel)

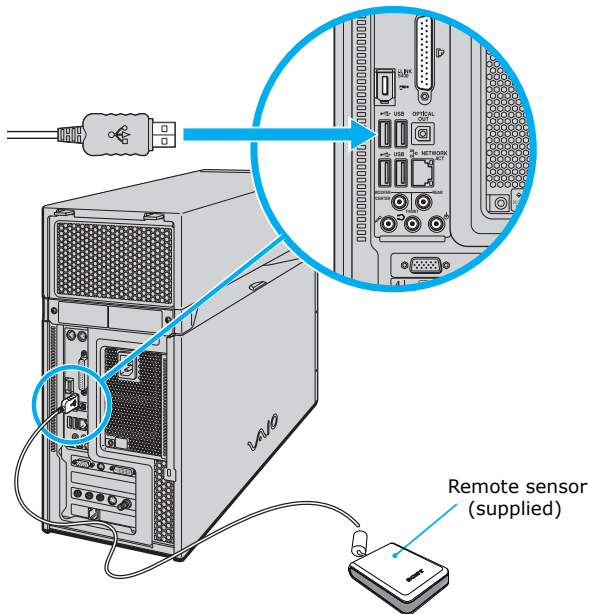

* Two (2) remote sensor controls are supplied. You can use your remote control to operate two separate set-top boxes.

To connect the remote sensor control

- 1 Plug the remote sensor control's cable into either jack (1 or 2) located on the back of the remote sensor.

 When you attach the remote control sensor to a cable or satellite set-top box, you can control the set-top box functions with your remote control.

Connecting the remote sensor and remote sensor control

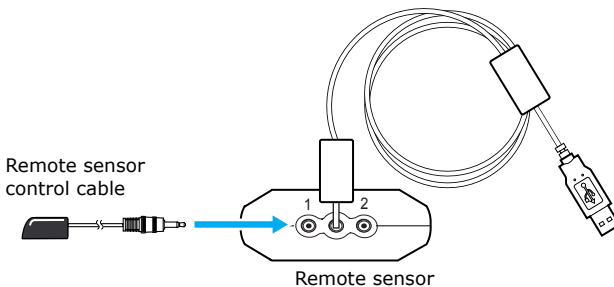

- 2 Remove the adhesive tape cover, located on the bottom of the remote sensor control.

- 3 Press the remote sensor control onto the set-top box near the infrared port, without covering the port.

 If the remote sensor control covers the infrared port on the set-top box, you cannot use the remote control supplied with the set-top box.

Attaching the remote sensor control cable to a cable or satellite set-top box

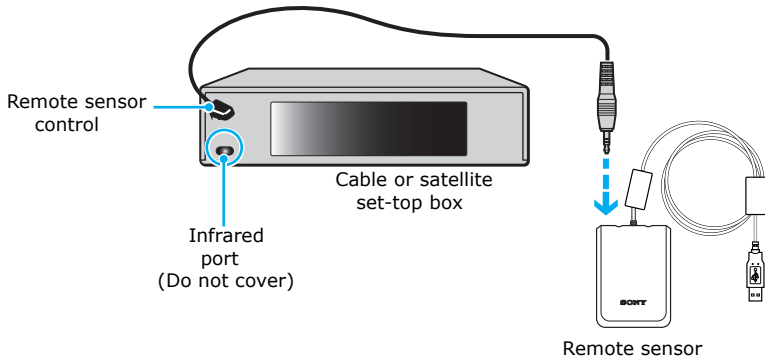

Connecting Other Devices

This section illustrates how to connect other devices to your VAIO Digital Studio® computer. Your computer has both audio and video connection capability. You can locate the appropriate connections on the back panel or behind the lower bottom panel on the front of the computer. You can connect a VCR or camcorder, using the composite audio In jacks. Your VCR or camcorder may have either standard video or S-video connection capability.

Connecting a device with an audio cable

- 1 Connect a dual audio cable (optional) to the composite audio L and R In jacks, located on either the front or rear panels of your computer.
- 2 Connect the other ends of the dual audio cable to your VCR or camcorder.

To connect a VCR or camcorder using an audio and S-video cable

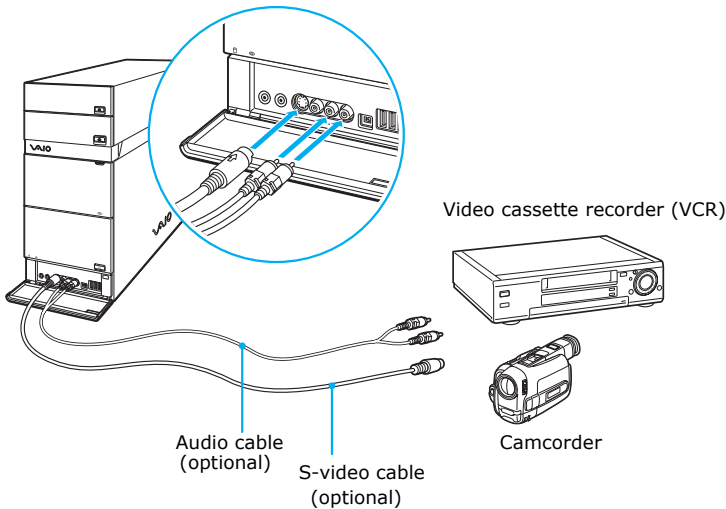

Connecting a device with an S-video cable

- 1 Connect an S-video cable (optional) directly into the S-video jack on either the front or back panel of your computer.
- 2 Connect the other end of the S-video cable into the appropriate port on your compatible VCR or camcorder.

Connecting a device with a stereo A/V dubbing cable

- 1 Connect a stereo A/V dubbing cable with triple RCA plugs at each end (optional) directly into the composite video port, composite audio L and R jacks, located on either the front or back panel of your computer.
- 2 Connect the other ends of the stereo A/V dubbing cable into the appropriate jacks on your compatible VCR or camcorder.

Connecting a TV monitor (display)

- 1 Connect the video connector end of the video cable adapter* to the TV Out (S-video/video) jack on the back panel of your computer.
- 2 Connect the jack end of the video cable adapter to either end of a video cable (optional). Connect the other end of the video cable to the Video-In jack on your TV monitor or display, located on either the side or back of your TV monitor/display.

Connecting a TV monitor or display

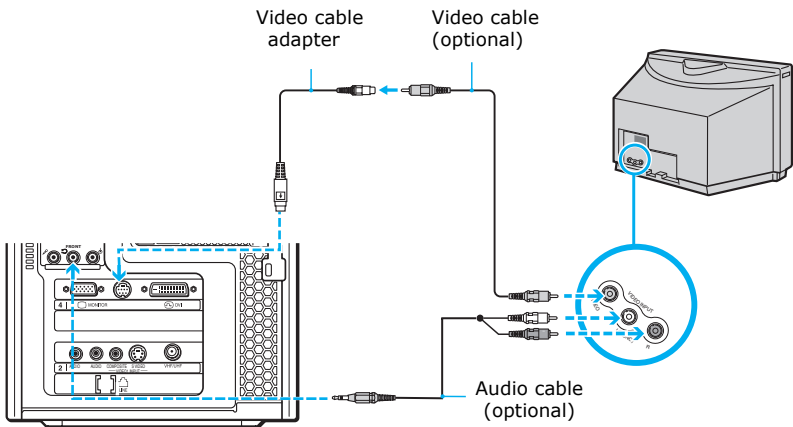

* The video cable adapter is supplied with certain VAIO computer models. See your computer's specifications sheet for information about supplied accessories.

- 3 Connect the single-jack end of an audio cable (optional) to the Headphones jack located on the front or back panel of your computer. Connect the double-jack end of the audio cable to the Audio-In (L/R) on your TV monitor or display. (The Audio-In jacks may be located on the side or rear of your TV monitor/display.)

 The video cable adapter is not necessary, if you use an S-video cable to connect your TV to the computer's TV out (S-video/video) jack.

Starting Media Center Software

You can instantly open Media Center features using the My Videos, My Pictures, My TV, or My Music buttons on your Media Center remote control or keyboard. You can also view recorded TV contents, by using the Recorded TV button on the remote control.

To use the remote control

- 1 Point the remote control at the remote sensor and press .
- 2 Use the arrow buttons on the remote control to navigate and select menu options. Press the **OK** button to activate your selection.

 The remote control must be used within 26 feet (8 meters) of the front of remote sensor unit.

To use the keyboard

- 1 Press the desired Media Center button, located at the top of the Media Center keyboard.
- 2 Use the directional arrows on the keyboard to navigate and select menu options. Press **Enter** to activate your selection.

To use the mouse

- 1 Click **Start** from the Windows taskbar and select **Media Center** from the **Start** menu. The **Media Center** main window appears.
- 2 Move the mouse to navigate and select menu options. Left-click the mouse to activate your selection.

Troubleshooting

This section describes how to resolve common start up problems.

My computer does not start.

- ❑ Verify that the computer is plugged into a power source and that it is turned on. Check that the power indicator is lit on the front panel of the computer.
- ❑ Confirm that a disk is not in the floppy disk drive* (unless you are using a bootable floppy disk).
- ❑ Confirm that a CD or DVD is not in an optical drive (unless you are using bootable media).
- ❑ Confirm that the power cord and all cables are connected firmly.
- ❑ If you plugged the computer into a power strip or Uninterruptible Power Supply (UPS), make sure the power strip or UPS is turned on and working.
- ❑ Verify that the monitor is plugged into a power source and turned on.
If your computer has a built-in monitor, confirm that it is plugged into an appropriate power source and that the computer is turned on.
- ❑ Verify that the brightness or contrast control dials are adjusted correctly. (See the manual supplied with your display for details.)
- ❑ Confirm that the computer is not in Stand by mode by pressing any key on the keyboard.

What can I do if my computer or software stop responding?

You can try to locate and close the software program that has stopped responding.

- 1 Press the **Ctrl+Alt+Delete** keys. The **Windows Task Manager** window appears.
- 2 From the Applications tab, locate the software program that has the status message, “**Not responding.**”
- 3 Select the software program that has a **Not Responding** status and click **End Task**. Windows attempts to close the program.

* Certain VAIO computers are not equipped with a floppy disk drive. You can purchase this equipment separately.

If your computer does not respond or the software program does not close:

- 1 Save and close any open files, if possible.
- 2 Press the **Alt+F4** keys. The **Shut Down Windows** window appears.
- 3 Click the drop-down list box and select **Restart**.
- 4 Click **OK**. The computer turns off and restarts.

If the **Shut Down Windows** window does not appear:

- 1 Press **Ctrl+Alt+Delete**. The **Windows Task Manager** window appears.
- 2 Click **Shut Down**.
- 3 Restart your computer.

If your computer still does not respond and you cannot restart, shut down your computer by pressing and holding the power button for more than six seconds.

If the software program continues to stop responding or causes your computer to stop responding, contact the software publisher or designated technical support provider.



Pressing and holding the power button for more than six seconds may result in the loss of data from files that are currently open.

How do I set up a dial-up connection?

After you have connected your computer's modem to a telephone wall jack, follow these steps to set up your dial-up connection to the Internet:

- 1 Click **Start** from the Windows taskbar and select **All Programs**.
- 2 Point to **Accessories**, point to **Communications**, and then click **New Connection Wizard**. The **New Connection Wizard** appears.



The **Location Information** and the **Phone and Modem Options** windows appear, when using your computer for the first time. Enter your information as requested and continue to the **New Connection Wizard** window.

- 3 Follow the on-screen instructions to finish setting up your dial-up connection.

Support Options

Sony provides several options to help solve common problems or to locate support for your VAIO® computer. This section describes all available resources and offers suggestions on how to access this information for maximum results.

Immediate Help and Support

You can locate helpful information immediately by consulting your hard copy guides and supplements, or by accessing the online Computer User Guide and individual software Help files.

Your computer is supplied with these support options:

- ❑ **VAIO® Computer Quick Start** — The Quick Start contains information on how to set up your computer quickly and easily. You can find instructions on how to connect power cords, cables, peripheral devices, and register your computer with Sony®. The Quick Start can also provide basic troubleshooting support.
- ❑ **About RAID Systems** — This informative booklet contains an overview of RAID-0 and RAID-1 levels, along with simple instructions on RAID configuration. This guide is available only with configure-to-order (CTO) computers that are shipped as RAID-0 or RAID-ready.
- ❑ **VAIO® Recovery Options Guide** — This online guide provides information about restoring individual software programs, software drivers, drive partition(s), or your entire hard disk drive to the original factory installed settings.

To access this information:

- 1 Click **Start** in the Windows® taskbar, then click **Help and Support**.
- 2 From the **VAIO Help And Support Center**, click **VAIO Recovery Options**.

- ❑ **VAIO® Computer User Guide** — The online User Guide provides information about configuring, maintaining, and upgrading your computer. This support resource offers a variety of available topics, enabling you to quickly view specific information using context-sensitive search features.

To access the online user guide:

- 1 Click **Start** in the Windows® taskbar, then click **Help and Support**.
- 2 From the **VAIO Help And Support Center** menu, click **VAIO User Guide**.

- ❑ **Media Center User Guide** — This online guide provides instructions and helpful information on using the Microsoft® Windows® XP Media Center software features.

To access the Media Center User Guide:

- 1 Click **Start** in the Windows taskbar, then click **Help and Support**.
- 2 From the **VAIO Help and Support Center** menu, click **Media Center User Guide**.

- ❑ **Specifications** — The online specifications sheet describes the hardware and software configuration of your VAIO computer. To view the online specifications sheet:

- 1 Connect to the Internet.
- 2 Go to the Sony online support Web site at *<http://www.sony.com/pcsupport>*.
- 3 Click the **Documentation** link and follow the on-screen instructions to locate your model's specifications sheet.

- ❑ **Preinstalled software Help files** — Each preinstalled software program provides online Help within the software, that describes the software's features. In these Help files, you can find tutorials that teach you to use the software and locate troubleshooting support, should problems occur. To access software Help files:

- 1 Click **Start** in the Windows taskbar and point to **All Programs**. A submenu appears, listing all preinstalled software programs.
- 2 Click the desired software program.* The software's main window appears.

* You can locate the online Help for Sony® software programs by pointing to the individual software program's icon and selecting Help from the submenu.

- 3 From the menu bar, click **Help**. The software program's **Help** appears.
- VAIO Software** — This feature provides specific information on preinstalled software on your computer.
To access this online software information
 - 1 Click **Start** in the Windows taskbar.
 - 2 Click **Welcome to VAIO life**.

Resources for Additional Help and Support

If the information provided with your VAIO® computer does not offer an immediate solution, or you would like to get direct support, try these additional help and support resources.

Sony online support Web site

Online help and support are available 24 hours a day, seven days a week, when you visit the Sony online support Web site. You can access the Web site at <http://www.sony.com/pcsupport>.

The Sony online support Web site provides:

- Information about your specific computer model, such as
 - hardware and software specifications.
 - safety and legal information.
 - quick solutions to common problems.
- An automated tutorial library that contains interactive, easy-to-understand lessons on using your computer's hardware and software features.
- Links that enable you to:
 - quickly find the nearest Sony service center locations.
 - arrange for repairs or check repair status.
 - review warranty information.
 - e-mail your question or comments to the Sony Customer Information Services Center.
 - check pricing and availability for products, accessories and parts, as well as purchase online.
 - access the Sony Solutions Knowledge Base, a database that contains answers to many frequently asked questions.

Sony Customer Information Services Center

If other support options do not resolve your issue, you can contact a Sony Support representative directly.

Before making a call to the Sony Customer Information Services Center, have this basic information readily available.

- 1 VAIO® computer type.
- 2 Model number.
- 3 Serial number *

Example:



- 4 Operating system.
- 5 Hardware feature or software program that has a problem. (See the online *VAIO® Computer User Guide* for the appropriate software technical support information.)
- 6 Brief description of the issue.

For VAIO® computers purchased in the U.S. and Canada, contact a Sony Support representative at 1-888-476-6972.

* The serial number is located on the back panel of your computer. The serial number is on a white barcode label.

For customer support information, go to:
<http://www.sony.com/pcsupport>

VAIO Homepage
<http://www.vaio.net>
© 2004 Sony Electronics Inc.
Printed in USA

