



Motion™ C5

User's Guide

Windows XP Tablet PC Edition 2005

© 2007 Motion Computing, Inc. All rights reserved.

This document contains information protected by copyright. No part of this document may be reproduced in any form without written consent from Motion.

The information in this document is provided "as is" and is subject to change without notice. Motion is not liable for errors or omissions in this document.

Motion, Motion Computing, Speak Anywhere, and View Anywhere are trademarks or registered trademarks of Motion Computing, Inc. in the U.S.A. and other countries.

Acrobat is a registered trademark of Adobe Systems Incorporated.

Atheros, the Atheros logo, Super G, Super A/G, Wake-on-Wireless, and Wake-on-Theft are registered trademarks of Atheros Communications, Inc.

AuthenTec is a registered trademark of AuthenTec, Inc.

Bluetooth is a registered trademark owned by the Bluetooth SIG, Inc., U.S.A. and licensed to Motion Computing, Inc.

Intel, Intel Inside, the Intel Inside logo, Pentium, Centrino, and PROSet are trademarks or registered trademarks of Intel Corporation or its subsidiaries in the United States and other countries.

Knowles and IntelliSonic are trademarks or registered trademarks of Knowles Acoustics, Inc.

OmniPass is a trademark of Softex, Inc.

Wi-Fi is a registered trademark of the Wi-Fi Alliance.

Microsoft Windows, Windows XP, Windows XP Tablet PC Edition, and Windows Journal are trademarks or registered trademarks of Microsoft Corporation in the United States and/or other countries.

SigmaTel is a registered trademark and Universal Jacks is a trademark of SigmaTel Corporation.

End users may not loan, rent, lease, lend, or otherwise transfer the CDs or DVDs provided for recovery purposes to another user, except as permitted in the End User License Agreement for such product.

This product incorporates copy protection technology that is protected by U.S. and foreign patents, including patent numbers 5,315,448 and 6,836,549, and other intellectual property rights. The use of Macrovision's copy protection technology in the product must be authorized by Macrovision. Reverse engineering or disassembly is prohibited.

Motion Computing, Inc. has made every effort to identify trademarked properties and owners on this page. All brands and product names used in this document are for identification purposes only and may be trademarks or registered trademarks of their respective companies.

The warranties for Motion products are set forth in the express limited warranty statements accompanying such products. Nothing in this document constitutes an additional warranty.

The Motion Computing products and services may be covered by one or more patent-protected inventions. Additional patents may also be pending. For more information, see

www.motioncomputing.com/info/patents.asp.

Getting Started

1

The Motion™ C5 is a new type of computer designed for health care users, that integrates traditional computer features with data capture technologies, digital ink, and speech recognition.

The C5 is the first product in this new category, called the mobile clinical assistant, and differs from other convertible and slate devices in the following ways:

- Minimizes ports and connectors, creating a semi-sealed device that is easier to clean and disinfect.
- Includes several built-in data capture technologies—such as a bar code scanner, RFID reader, and camera—that eliminate the need for bulky external devices.
- Delivers an optimal balance of performance and portability.

If you have never used a mobile clinical assistant or a pen-based computer, use the information in this section to get started quickly. If you have, skip to the next chapter to learn about the features of the Motion C5. If there is a particular feature you want to learn about, look on the Contents page. Because you typically use a pen instead of a mouse with the Motion C5, we use the term *tap* instead of *click* in most situations.

For safety information, see the *Safety and Regulatory Guide* packaged with the C5.

Overview

The following illustrations show the features of the Motion C5.



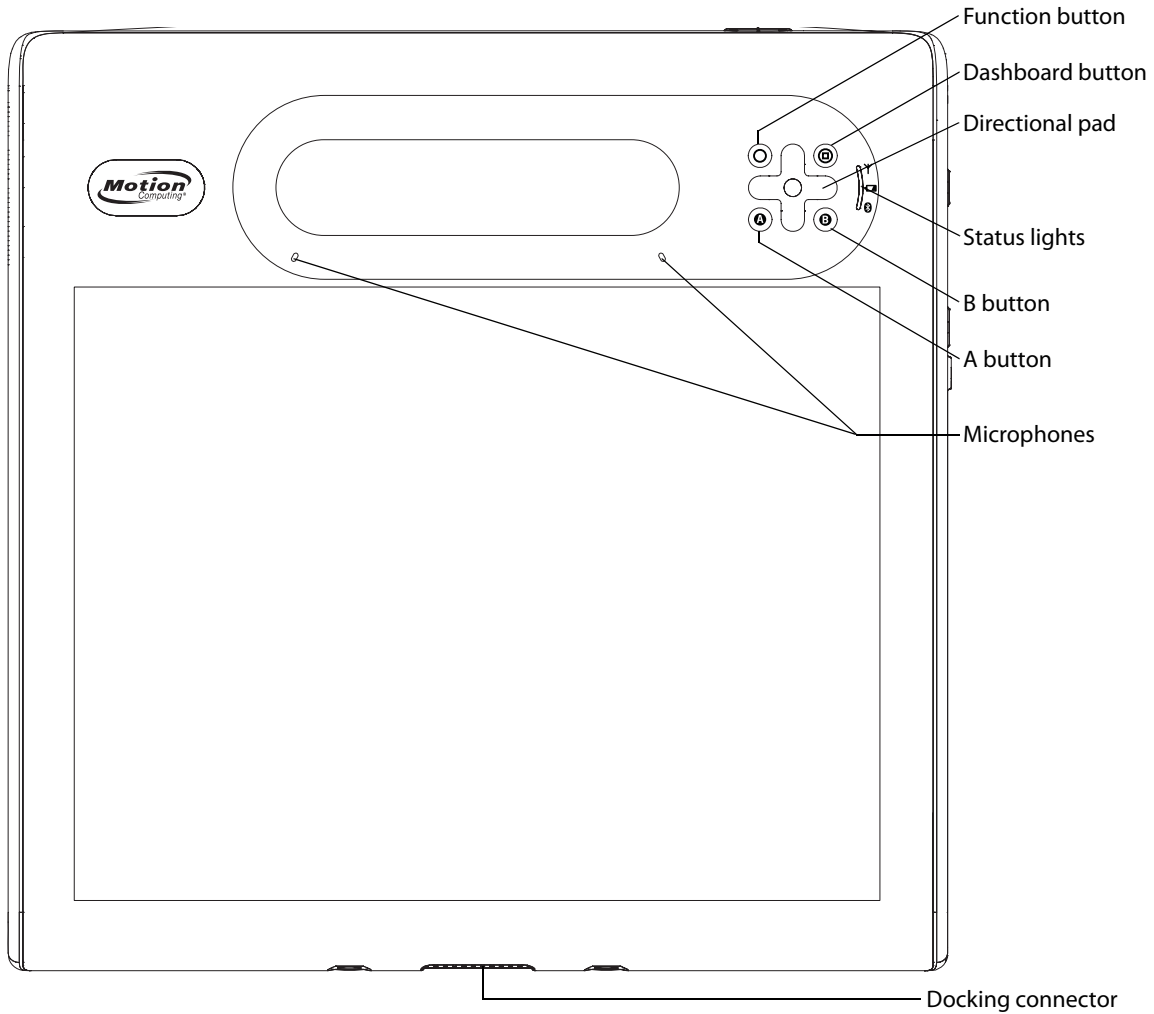

Front

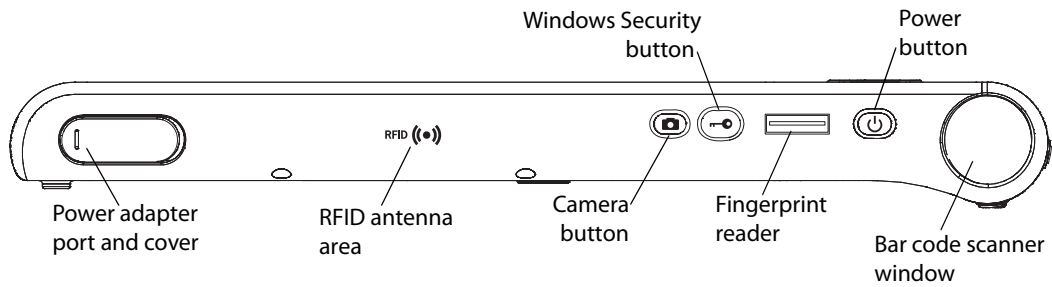

Ⓞ	Dashboard button	Open Motion Dashboard (page 9).
Ⓞ	Function button	Activate secondary functions for other buttons (page 9).
	Directional pad	Use for basic navigation. Equivalent to the arrow keys on a keyboard. The center button is equivalent to Enter (page 9).
Ⓐ	A button	Set up a custom action (page 9).
Ⓑ	B button	Set up a custom action (page 9).
	Status lights	Show wireless, battery, and Bluetooth status (page 8).
	Microphones	Record sounds and use for speech recognition (page 11).
	Docking connector	Interface for the C5 Docking Station.



Right side

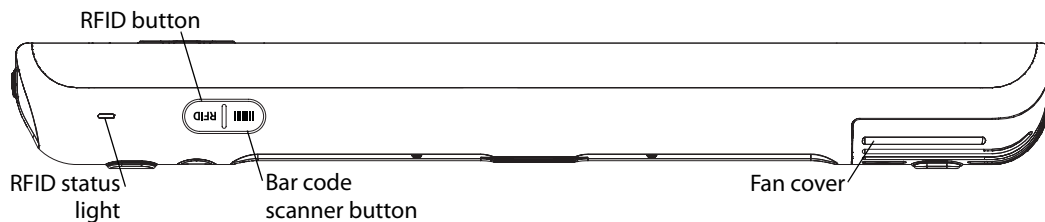

	Power adapter port and cover	Connect the power adapter (page 15).
	RFID antenna area	Scan area for reading RFID tags (page 12).
	Camera button	Use to trigger the built-in camera (page 11).
	Windows Security button	Use to log on to or lock the Motion C5. Equivalent to Ctrl+Alt+Del on a keyboard (page 9).
	Fingerprint reader	Scan your fingerprints for added security. You can also use the fingerprint reader as a navigation device (page 10).
	Power button	Turns the Motion C5 on and off.
	Bar code scanner window	Reads codes from bar code labels (page 13).

Top side



	RFID status light	Shows the status of the RFID scanner.
	RFID scanner button	Use to trigger the RFID scanner (page 12).
	Bar code scanner button	Use to trigger the bar code reader (page 13).
	Fan cover	Protects the fan assembly.

Back side

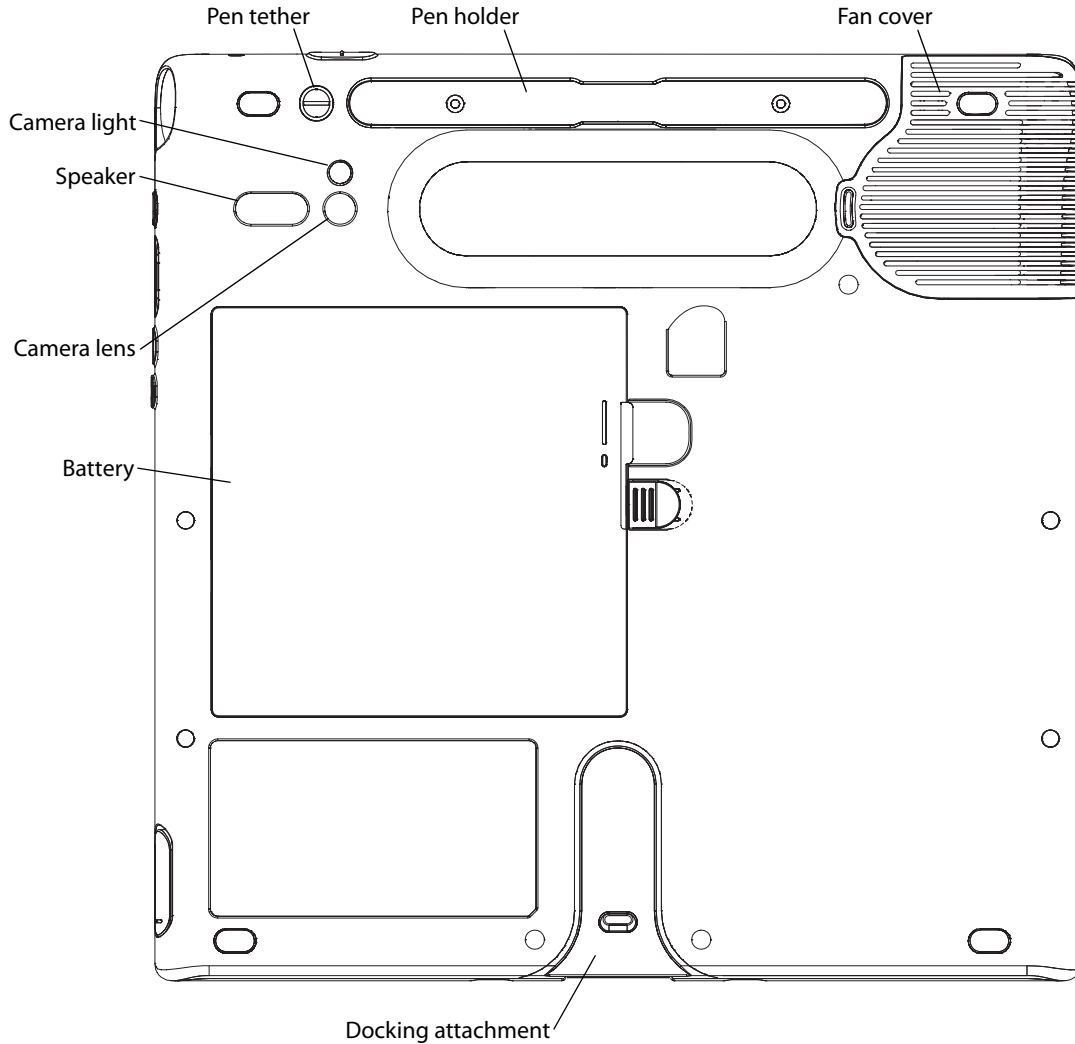

	Pen tether	Attach the pen tether.
	Pen holder	Store the pen when not in use (page 8).
	Fan cover	Protects the fan assembly.
	Camera lens	Capture images to the hard disk drive (page 11).
	Camera light	Provides light for the built-in camera.
	Speaker	Listen to audio (page 12).
	Battery	Powers the Motion C5 when it is not plugged in or docked (page 14). Note: The Microsoft Windows Certificate of Authenticity is under the battery.
	Docking attachment	Attachment point for the C5 Docking Station.

Setting up the Motion C5

The C5 is self-contained, so you can start using it immediately. If you are using a C5 Docking Station, refer to the instructions that came with the docking station. You should connect AC power until the battery is fully charged. Use the following steps to get started.

For safety information, see the *Safety and Regulatory Guide* packaged with the C5.

Step 1: Plug in the power adapter

- Plug the power cord in to the power adapter. Insert the power cord into an outlet and the power adapter plug into the power adapter port on the C5

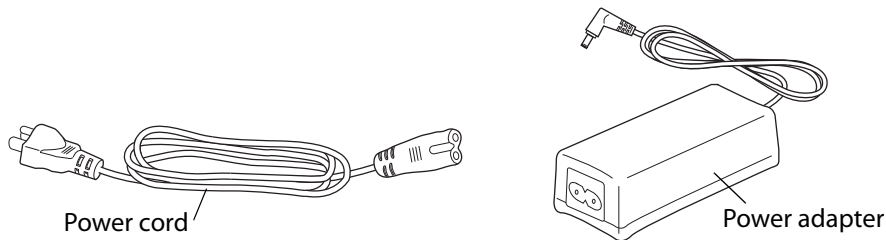

Step 2: Turn on the Motion C5

- Press the power button.

As the Motion C5 starts, the light on the power button comes on.

The first time Windows starts, the Windows XP Tablet PC Edition 2005 Tutorials appear. If you do not want this screen to appear every time you start the computer, select **Do not show me this again**. To run the tutorials later, select **Start > All Programs > Tablet PC > Tablet PC Tutorials**.

Step 3: Calibrate the digitizer

With the Motion C5, you will frequently use a pen instead of a mouse and keyboard to interact with the computer. Use the pen to move the pointer around the screen, and tap the screen to click. Use Tablet PC Input Panel (page 20) to enter text.

The digitizer detects the position of the pen. You should calibrate the digitizer the first time you start the C5, and again whenever the pointer does not align with the pen tip.

To calibrate the digitizer

1. Press the Dashboard button (Ⓢ) to start Motion Dashboard.

You can use Motion Dashboard to configure the Motion C5 and to start commonly used applications. See "Using Motion Dashboard" on page 18.

2. Under **Pen**, tap **Calibrate Digitizer**.
3. Follow the instructions in the calibration program.

Note: If you are left-handed, see "How do I adjust the C5 for left-handed use?" on page 62.

Step 4: Get familiar with the Motion C5

Motion Computing offers free Web-based Quick Start Training that you can use to familiarize yourself with the features of the Motion C5. If you are new to pen-based computing, you can use the training to get started quickly. You can find the training at <http://training.motioncomputing.com>.

You can also use the Windows Tablet PC tutorials to learn about the special capabilities of Windows XP Tablet PC Edition. Windows XP Tablet PC Edition includes many features that other editions of Windows XP do not, such as pen support, digital ink input, and handwriting recognition.

To start the tutorials, select **Start > All Programs > Tablet PC > Tablet PC Tutorials**.

Features

2

The Motion C5 has the power and features of a traditional computer, while giving you the added mobility and versatility of a portable computer.

Use the information in this chapter to get more familiar with the hardware features of Motion C5, such as the buttons, camera, RFID reader, bar code scanner, and wireless adapters.

The Motion C5 includes the following features:

- Intel® Centrino® Mobile Technology
- Intel® Core™ Solo Processor U1400 1.2 GHz
- Mobile Intel® 945GM Express Chipset
- DDR2 533 MHz SDRAM
- 256MB video RAM with Intel Dynamic Video Memory Technology
- 10.4" XGA TFT LCD with 1024 x 768 native resolution
- Intel Display Power Saving Technology
- Integrated Wi-Fi (802.11a/b/g) networking
- Integrated Bluetooth®
- Integrated fingerprint reader
- Integrated 2.0 megapixel camera
- Integrated 1D/2D Barcode reader (optional)
- Integrated 13.56MHz passive RFID reader
- Integrated 13.56MHz high-frequency passive RFID tag

Pen

An important difference between traditional PCs and the Motion C5 is that you frequently use a pen instead of a mouse and keyboard to interact with the computer. The pen includes a pressure-sensitive tip, a function button, and an eraser. The pen contains no batteries and requires no external power.

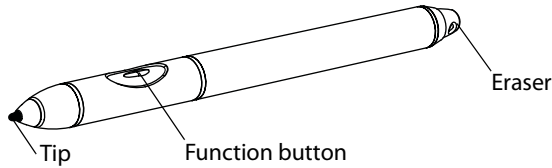

For information about using the pen, see “Using the pen” on page 19.

Status lights

You can use the indicator lights on the front of the Motion C5 to monitor the status of the unit. The following illustration shows the status lights on the C5.

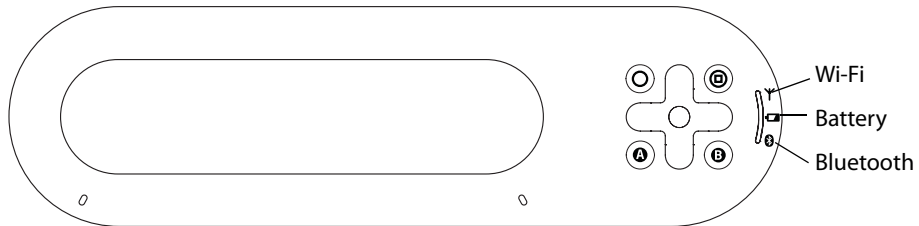

Light	Status	Description
Wi-Fi	Steady green	The Wi-Fi (802.11 a/b/g) adapter is enabled
Battery	Steady amber	The battery is charging
	Steady green	The battery is charged
	Flashing amber (slow)	10% charge remaining
	Flashing amber (fast)	Less than 5% charge remaining
Bluetooth	Steady green	The Bluetooth adapter is enabled

Front panel buttons

You can use the buttons on the front of the C5 to perform many functions without having to use the pen. The buttons are customizable, so you can modify their functions to suit the way you work. See “Configuring front panel buttons” on page 21.

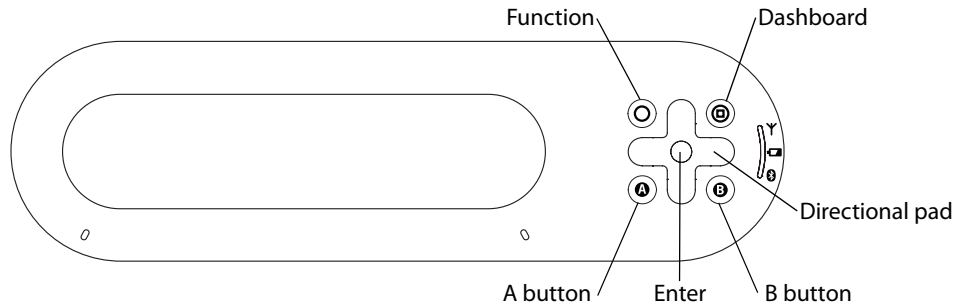

Button	Primary	Secondary (Function+button)
Function	Activates secondary function for other buttons	N/A
Dashboard	Starts Motion Dashboard	Starts Windows Journal
Directional pad	Use to move the pointer or navigate through documents. Equivalent to arrow keys on a keyboard.	Left = Shift+Tab Right = Tab Up = Page Up Down = Page Down
Enter	Makes a selection. Equivalent to the Enter key on a keyboard.	Windows logo key
A	Application-specific	Rotates the display orientation.
B	Application-specific	Cancels the current task. Equivalent to the Esc key.

The directional pad orientation rotates to match the display orientation. To move the pointer in a certain direction, press that direction on the pad regardless of orientation. For example, “up” in landscape orientation becomes “left” in portrait orientation.

Windows Security button

You can use the Windows Security button to log on to or lock the C5. Pressing the Windows Security button is equivalent to pressing Ctrl+Alt+Del on a keyboard.



Display

The Motion C5 includes a 10.4" XGA TFT LCD display with the following features:

- A highly readable LCD (liquid crystal display).
- 1024 x 768 native resolution.
- Intel Display Power Saving Technology.
- A protective layer that offers a firm writing surface and minimizes glare.
- A digitizer panel that enables handwritten entry with the pen.

The optional View Anywhere™ display enhances outdoor viewing and bright-light indoor viewing. The View Anywhere display includes all the features of the standard display, while adding increased sunlight contrast ratio, increased brightness, and decreased glare.

Fingerprint reader

Using the fingerprint reader, you can log on to the Motion C5 by scanning your fingerprint instead of entering a password. This feature presents another level of security for the C5.

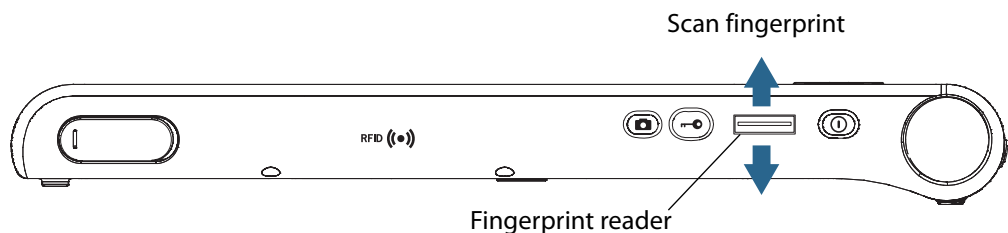

You can use the OmniPass application to associate your fingerprint with passwords for Web pages and other applications. For information about setting up and using the fingerprint reader, see "Capturing a fingerprint" on page 36.

Security

The C5 provides a safe computing environment that enables strong security protection and serves as the foundation for complementary security technologies. The core security features include password-protected Phoenix TrustedCore BIOS with HDD locking and networking control, optional ComputraceComplete tracking software, a built-in fingerprint reader, Dashboard Security Center, and TPM (Trusted Platform Module) 1.2.

With TPM and the Infineon Security Platform Tools, you can create and manage digital certificates for user and platform authentication. These features are most commonly used by enterprises and are typically set up by the system administrator. To learn more about TPM, go to www.motioncomputing.com/support/support_documentation.asp.

The optional ComputraceComplete tracking software can help you recover a lost or stolen computer.

Camera

The C5 includes a built-in 2-megapixel auto-focus camera that you can use to take pictures and save them to the hard disk drive. The camera lens is on the back of the C5, and includes a light to illuminate the subject. The camera produces pictures in BMP format with a resolution up to 1600 × 1200 pixels.

The following table shows detailed specifications for the camera.

Item	Value
Sensor array	CMOS sensor 2.0 megapixel
Pixel size	3.0µm x 3.0µm
Optical format	1/3"
S/N ratio	40dB
F number	2.8
Focus	Auto focus @ 10cm ~ infinity
Image resolution	1600 x 1200 1280 x 1024 1024 x 768 800 x 600 640 x 480 320 x 240
Frame rate	2M @ 11fps: 1.3M @ 15fps VGA @ 30fps QVGA @ 30fps (MJPEG mode)
White balance	Automatic
Exposure	Automatic

For information about using the camera, see "Using the camera" on page 20.

DataGuard

The C5 includes the DataGuard feature, which detects shocks, extreme vibrations, and falls. If detected, DataGuard moves the drive heads away from the disk, which can prevent hard drive failures and data loss. For more information, go to Control Panel and open DataGuard.

Microphones

The Motion C5 is equipped with two liquid-resistant microphones that you can use to record audio, dictate notes, and use voice commands without the need for an external microphone.

For information about using the microphones, see "Using the built-in microphones" on page 26.

Speaker

The Motion C5 includes a sealed speaker that can be used for audio warnings or confirmation, dictation, videos, or other multimedia applications.

Docking connector

The docking connector is used to attach the C5 to a docking station. When the C5 is connected to a docking station, you can use the ports on the docking station to connect a monitor, keyboard, mouse, or other external USB devices.

For more information about the C5 Docking Station and other accessories, go to the Motion Computing accessories page at www.motioncomputing.com/accessories.

RFID reader

The Motion C5 includes an integrated 13.56 MHz RFID (Radio Frequency Identification) reader that you can use to retrieve information from RFID tags.

RFID tags use radio frequency (RF) transmissions to identify a product, animal, or person. RFID does not require direct contact or line-of-sight scanning, and can be scanned through many materials, including clothing. An RFID tag can store much more data than a typical bar code, and some RFID tags can both transmit and record data. RFID can be used for asset tracking, identification, process control, health care, and pharmaceutical applications.

The Motion C5 RFID reader supports the following formats:

- ISO/IEC 14443A/B
- ISO/IEC 15693
- ISO/IEC 18000-3

For information about using the RFID reader, see “Using the RFID reader” on page 25.

The Motion C5 also includes an integrated 13.56MHz high-frequency passive RFID tag that can be used for identification and short-range asset tracking.

Bar code scanner (optional)

The Motion C5 includes an optional integrated 1D and 2D bar code scanner that you can use to retrieve information from bar codes.

A bar code is a series of shapes on a contrasting background that can be optically read by a bar code scanner. Bar codes can be used for asset tracking, identification, process control, health care and pharmaceutical applications.

The Motion C5 can read the following symbologies without any additional configuration:

- Aztec Code
- Code 128
- EAN-128
- EAN-UCC-CC-AB
- Code 39
- DataMatrix
- UPC-A
- UPC-E
- EAN-8
- EAN-13
- Interleaved 2 of 5
- PDF417
- Micro PDF417
- RSS-14
- RSS Limited

The Motion C5 can be configured to read the following symbologies:

- Codabar
- Codablock A
- Codablock F
- EAN-UCC-CC-C
- Code 93
- UPC-E1
- EAN ISBN
- EAN-ISMN
- EAN ISSN
- MSI
- MaxiCode
- Plessey Code
- QR Code
- RSS Expanded
- TLC 39
- Straight 2 of 5 TwoBar
- Telepen
- Code 11
- Australia Post
- BPO*
- Dutch Post
- Japan Post*
- Planet
- Postnet*

*These symbologies are special cases and, if enabled, may interfere with the scanner's ability to scan other Code128 barcode types, such as:

- CIP 128
- EAN-128 Irregular
- ISBT-128

For more information about the bar code scanner, see "Using the bar code scanner" on page 24.

Wi-Fi (802.11a/b/g wireless)

The Motion C5 has integrated Wi-Fi (802.11a/b/g) that you can use to connect to the Internet and other computers wirelessly. You can use Wi-Fi in many schools, hospitals, clinics, airports, and hotels.

Note: Wireless access requires an 802.11a, 802.11b, or 802.11g access point. Internet access requires a working Internet connection.

Your ability to use Wi-Fi depends on several conditions:

- Distance from the access point.
- Ability to connect to the access point.
- Access rights, which may require a user name and password.
- Security settings, such as whether the network broadcasts a network name or uses encryption.

For more information, see “Using Wi-Fi (802.11a/b/g)” on page 43.

Bluetooth wireless

The Motion C5 has an integrated Bluetooth adapter. With Bluetooth, computers and other devices—such as mice, keyboards, and PDAs—can be interconnected using a short-range wireless connection. Bluetooth devices can connect wirelessly at distances up to 33 feet (10 meters).

For more information, see “Using Bluetooth” on page 44.

Battery

The Motion C5 includes a high-capacity Lithium-ion battery that fits in to the back of the unit. Under normal conditions, you can run the C5 on battery power for about three hours. You can maximize battery life by optimizing your power scheme. See “Using power management” on page 29.

For information about charging and checking battery status, see “Using the battery” on page 32.



DANGER: To avoid personal injury, handle the battery with care. Do not open, puncture, short, or expose it to fire or water. Keep the battery in an ambient temperature of less than 104°F (40°C). For example, do not leave the battery in a closed car in hot weather for an extended time. For more information, see the *Safety and Regulatory Guide* packaged with the C5.

Power adapter

The power adapter provides power to the Motion C5 and charges the battery when it is attached. The power adapter has the following components:

- Power cord
- Power adapter

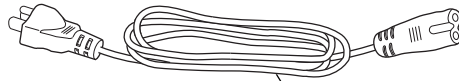

Power cord

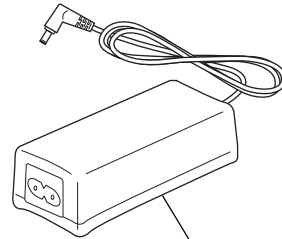

Power adapter



WARNING: Use the Motion power adapter with the Motion C5 only. Do not use the adapter to power any other electronic devices.

Using the Motion C5

3

The Motion C5 runs Microsoft Windows XP Tablet PC edition, which includes ink-to-text and word recognition, voice recognition, and improved security to help defend against viruses, worms, and other threats. And unlike PDAs or other handheld devices, the C5 runs any Windows XP-compatible application.

Use the information in this chapter to learn about common tasks, such as using the pen to enter text, using Motion Dashboard, using speech recognition, and customizing the C5 to fit the way you work.

Using Motion Dashboard

Motion Dashboard puts many common settings and tasks at your fingertips. For example, you can enable or disable Bluetooth and Wi-Fi, calibrate the digitizer, or check the remaining battery power.

To start Motion Dashboard

- Press the Dashboard button ((Ⓜ)) on the front of the C5.

To open a category, tap the appropriate icon on the left side.

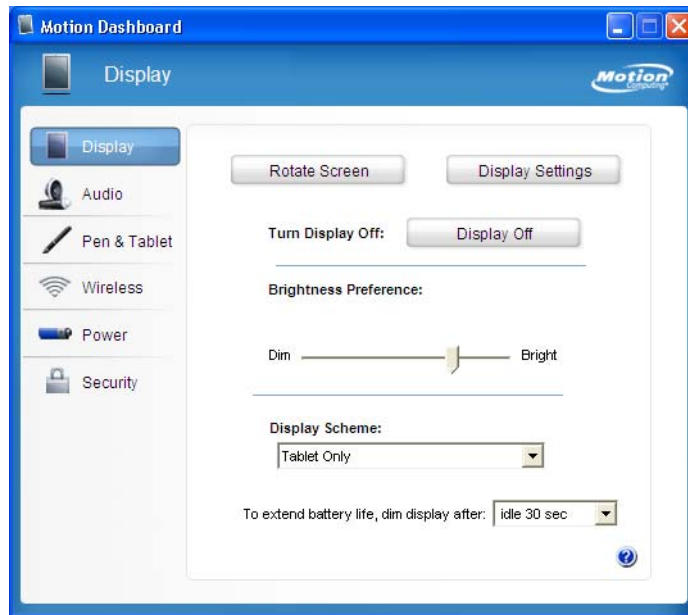

When you change a setting on Motion Dashboard, the change occurs immediately. You do not need to tap **Apply** or **OK**.

For more information, see Motion Dashboard Help.

Using the pen

You can use the pen to write on the display and navigate the operating system. A pen can feel more natural in your hand than a mouse, and you can use the pen while standing or walking. The following table show the various mouse actions and their pen equivalents.

Mouse action	Pen equivalent
Point	Point
Click	Tap
Double-click	Double-tap
Drag	Drag
Right-click	Tap and hold
Right-click	Press Function button and then tap

Some software applications, such as Microsoft Word and Microsoft PowerPoint, support ink drawing and ink annotations. Some applications, such as art or drawing programs, are designed specifically for ink input. For more information about a particular application, open the application help and search for “pen”, “ink”, or “digitizer”.

You can use Tablet PC Input Panel instead of a keyboard to enter text. For more information, see “Using Tablet PC Input Panel” on page 20.

Store the pen in the pen holder when not in use. To put the pen in the pen holder, press it until it clicks into place. To remove the pen, press down on one end and grab the other end.

For information about replacing pen tips, see “Replacing pen tips” on page 52.

Important: The C5 responds to the C5 pen only. Do not use a traditional pen, pencil, or stylus with the C5.

Configuring pen options

You can use pen options to enable or disable the pen function button and the pen eraser.

To configure pen options

1. Open Motion Dashboard to the Pen panel (page 18).
2. Tap the **Pen & Button Options** button.
3. In the Tablet and Pen Settings window, tap the **Pen Options** tab.
4. For pen buttons, do one of the following:
 - To enable the function button, select **Use pen button to right-click**.
 - To enable the eraser, select **Use the top of the pen to erase**.

Using Tablet PC Input Panel

You can use Tablet PC Input Panel instead of a keyboard to enter text on the Motion C5. Use the writing pad or the character pad to convert your handwriting to text, or tap characters using the on-screen keyboard.

You can also use Input Panel to dictate text or use voice commands. For more information about Speech Recognition, see “Using speech recognition” on page 27.

The following illustration shows Input Panel open to the writing pad.

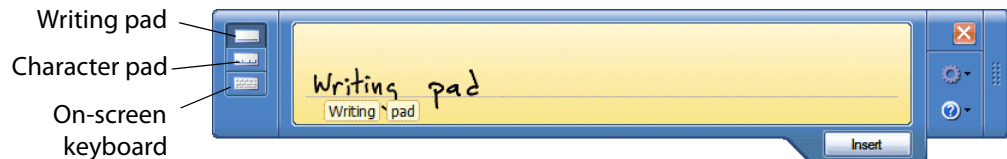

To start Input Panel

- Do one of the following:
 - Tap at the place you want to enter text, such as a text box. Then tap the Tablet PC Input Panel icon (🖊️).
 - Tap the Tablet PC Input Panel icon on the Windows taskbar.

To switch among the writing pad, the character pad, and the on-screen keyboard, tap the appropriate button.

Use the tutorial to get acquainted with Input Panel. Tap **Help**, then tap **Tutorial**.

For more information about using Input Panel, see the Input Panel Help.

Using the camera

You can use the built-in camera to take pictures. For more information about the camera, see “Camera” on page 11.

To use the camera

1. Press the Camera button to activate the camera and open the viewfinder.



2. Press the Camera button again to take a picture.
3. In the Pictures dialog box, do one of the following:
 - To save the picture, tap **Save**. In the Save As dialog box, specify a location in which to save the picture.
 - To delete the picture, tap **Delete**. In the confirmation dialog box, tap **OK**.

Configuring front panel buttons

As you become more familiar with the C5, you may want to customize the buttons on the front panel. You can configure the buttons to start your favorite program, run a command, or enter a key combination.

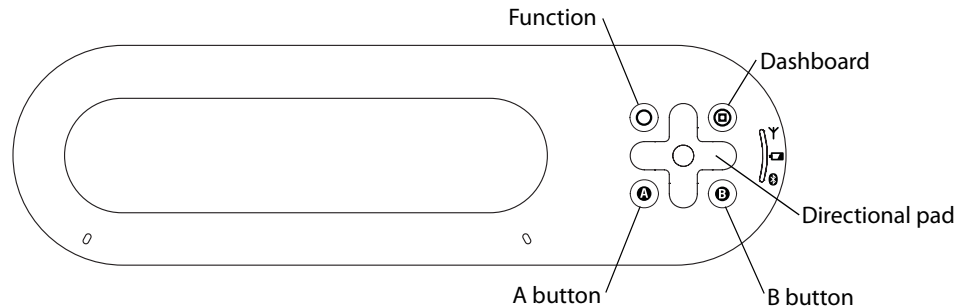

To configure the front panel buttons

1. Open Motion Dashboard to the Pen panel (page 18).
2. Tap **Pen and Button Options**.
3. Tap the **Tablet Buttons** tab.
4. Select the button combination you want to change. The currently selected buttons appear in red.
5. Tap **Change**.
6. For **Action**, select an action to assign to the button.

For some actions, you must enter more information, such as the location of a program to start. Tap **Help** for more information.

Note: To reset the buttons to their default values, tap the **Reset** button on the **Tablet Buttons** tab.

Using the display

Use the information in this section to customize your display settings. You can adjust the brightness level, rotate the display, and change the order in which the display rotates.

Adjusting the display brightness

Use this procedure to change the brightness of the display.

To adjust the display brightness

1. Open Motion Dashboard to the Display panel (page 18).
2. Set the Brightness slider to the appropriate level.

To maximize battery life, set the brightness scale to the dimmest level that you are comfortable with.

Changing the screen orientation

You can easily change the screen orientation to fit your current task. You may want to use the portrait orientation for filling out forms or reading an e-book. At other times, you may want a landscape orientation for Web browsing or sketching.

You can also use the front panel buttons to change the screen orientation. Press Function+A (page 9).

To change the screen orientation

1. Open Motion Dashboard to the Pen panel (page 18).
2. Tap the **Pen and Button Options** button.
3. Tap the **Display** tab.
4. In the Orientation list, select the screen orientation you want to use.

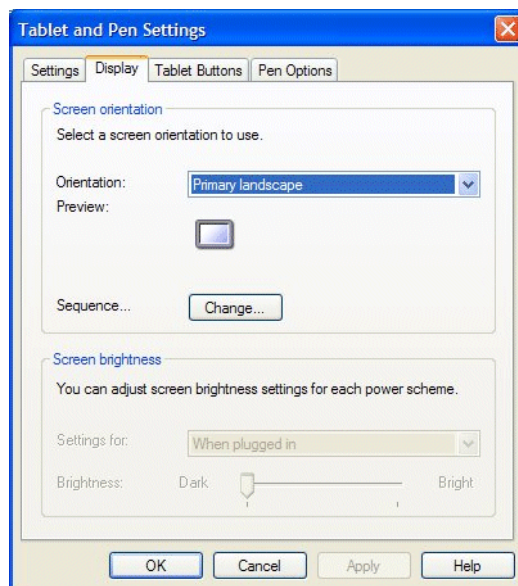

Note: If you change the screen orientation, you may need to recalibrate the pen. See “Calibrate the digitizer” on page 5.

You can also change the display orientation by tapping the Tablet and Pen Settings icon in the notification area and selecting **Change screen orientation**.

Changing the display rotation sequence

Use this procedure to change the order in which the display rotates.

To change the rotation sequence

1. Open Motion Dashboard to the Pen panel (page 18).
2. Tap the **Pen and Button Options** button.
3. Tap the **Display** tab.
4. For Sequence, click **Change**.
5. Select orientations for 1, 2, 3, and 4.

You can select **None** to skip a particular view in the rotation sequence.

Using the bar code scanner

You can use the built-in bar code scanner to retrieve information from bar codes. For more information about the bar code scanner, see “Bar code scanner (optional)” on page 13.

To use the bar code scanner

1. Open the application that you want to receive the bar code data and place the insertion point in the appropriate field.
2. Hold the C5 by the handle with the scanner window in front of you.
3. Aim the scanner window at the bar code.

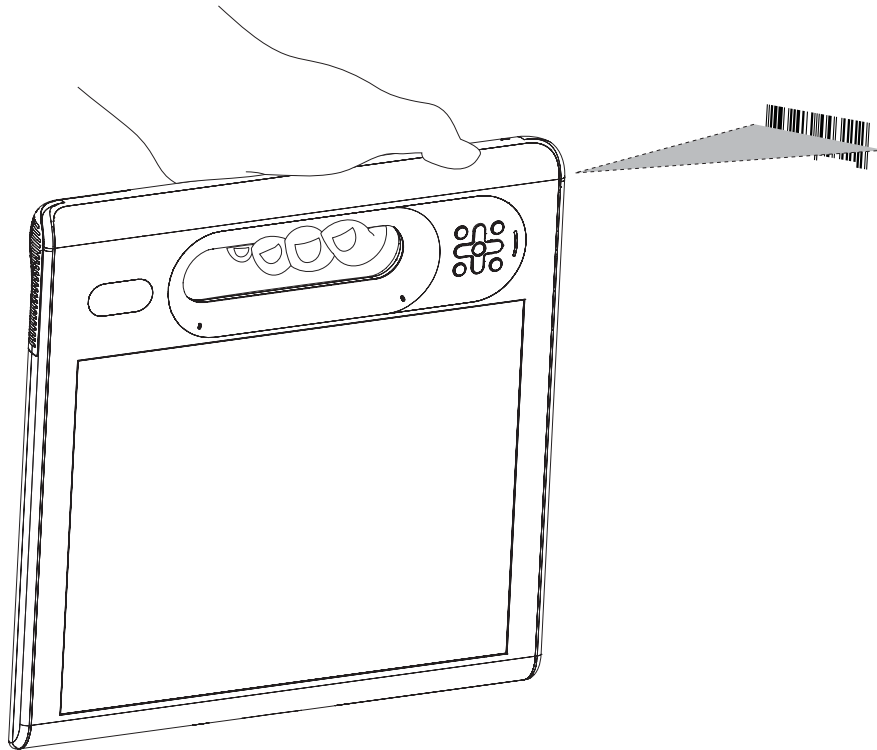

4. Press and release the Bar code scanner button on the top of the C5. Ensure that the scan beam covers the entire bar code.



If the scan was successful, the data will appear in the application and you will hear a beep sound as confirmation.

Using the RFID reader

You can use the built-in RFID reader to retrieve information from RFID tags. For more information about the RFID reader, see “RFID reader” on page 12.

To use the RFID reader

1. Hold the C5 by the handle with the right edge in front of you.
2. Aim the right edge of the C5 at the RFID tag. Ensure that the tag is 25–40 mm from the RFID antenna scan area.

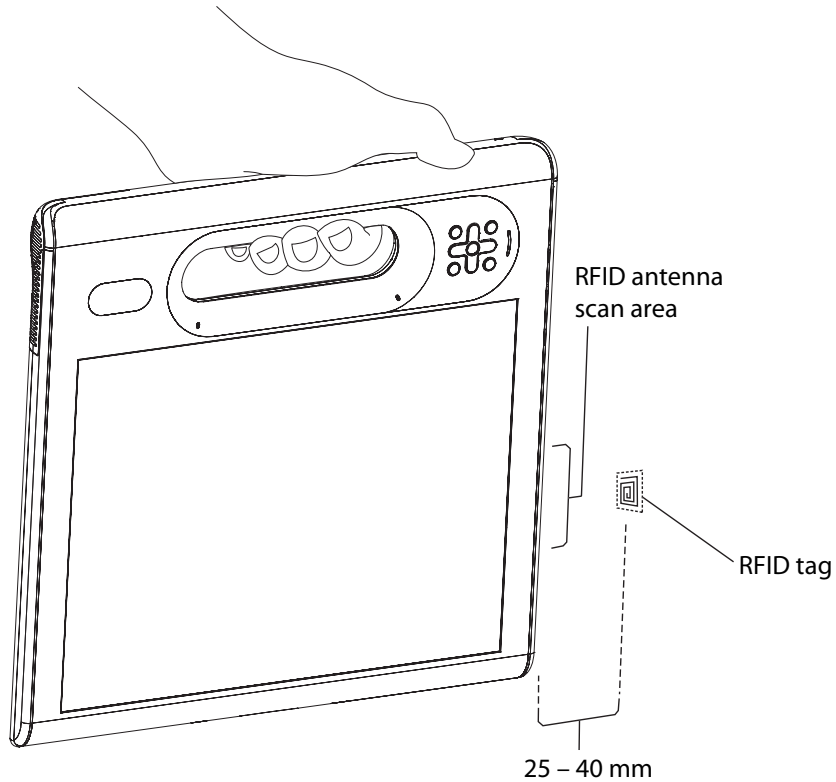

3. Press and release the RFID button on the top of the C5. The RFID light will come on to indicate that the unit is scanning.



The RFID light goes off and the unit beeps to indicate a successful scan. The Ascii and Hex data appears in the RFID Tag Data window.

Note: RFID tags are typically used with specialized applications.

Using the built-in microphones

You can use the built-in microphones to record audio, dictate notes, and use voice commands. The two microphones are used at the same time to optimize sound detection for speech recognition and voice recording.

You can use the Speak Anywhere acoustics software to fine tune the built-in microphones to suit your environment. The software enables you to use the microphones in a variety of settings, including small or large groups, noisy environments, or for individual dictation or voice commands. The software improves the microphone reception by:

- Removing all sounds outside of the user-defined angle of acceptance.
- Minimizing background and ambient noise.
- Removing echo caused by the microphone picking up the speaker output (feedback).

Setting up the angle of acceptance

The angle of acceptance defines how the built-in microphones detect sounds. You can remove all sounds outside of a specified angle. When recording, dictating, or using voice commands, you may need to adjust this setting until you achieve the desired results.

To set up the angle of acceptance

1. Open Motion Dashboard to the Audio panel (page 18).
2. Under Microphone, select one of the following:
 - **Narrow angle.** Configures the microphones to detect sound on a narrow angle near the bottom center of the display. Narrow is the best setting for dictation, Voice over IP, or “voice noisy” environments.
 - **Medium angle.** Configures the microphones to detect sound at a wider angle. Medium is the best setting for a small group, conference table, or “voice quiet” environment.
 - **Wide angle.** The microphones detect sound at the widest angle. If the microphones are detecting too much background noise, change to a narrower setting.

If a sound is loud enough, the microphones will pick it up regardless of the angle of acceptance setting.

You can limit the detection of these outside sounds by turning down the microphone level and speaking louder. This reduces the microphones’ range and restricts the capability to detect extraneous sounds.

Setting up the skew angle

The default sound detection area is directly in front of the C5, but you can use the skew angle to offset the sound detection area toward one side or the other.

To set up the skew angle

1. Open Motion Dashboard to the Audio panel (page 18).
2. Under Microphone, ensure that **Narrow Angle** or **Medium Angle** is selected. You cannot use a skew angle with the Wide angle setting.
3. Move to where you want the microphone to detect your voice.
4. Tap **Calibrate**. A block of text appears.
5. Read the text aloud, speaking normally towards the microphones. This process takes about 30 seconds.

In many cases, you will not need to calibrate the built-in microphones because the audio system filters out many unwanted sounds. If you are dictating in an office or recording during a meeting, the audio system may work well with no additional calibration.

Note: The audio system does not store calibrations. If you change to another angle or position and then return to the previous one, you must recalibrate the audio system.

Using speech recognition

You can use speech recognition to interact with the Motion C5 by voice. You can dictate documents and emails, or use voice commands to control programs.

- **Dictation mode.** With Dictation mode, the computer listens to everything you say and converts your words to text. You can use dictation mode to enter text directly into any document or text box.
- **Voice command mode.** With Voice command mode, the computer listens for specific words that correspond to a list of available voice commands. You can use commands to switch between programs, save documents, copy, paste, or undo.

Setting up speech recognition

Before you can use speech recognition, you must configure the microphones and train the system for the characteristics of your voice. The entire process takes about 10 minutes. You should move to a quiet environment before starting this procedure.

To set up speech recognition

1. Open Motion Dashboard to the Audio panel (page 18).
2. Ensure that the speakers and microphone are set to appropriate levels.
3. Start Input Panel (page 20).
4. Tap the **Tools and Options** button (), then tap **Speech**.
5. Tap **Next** and follow the instructions in the setup program.

You can improve speech recognition by running additional speech training sessions. In Control Panel, open Speech.

Starting speech recognition

After you have set up speech recognition, you can start it from Input Panel.

To start speech recognition

1. Start Input Panel (page 20).
2. Tap the **Tools and Options** button (), then tap **Speech**.
3. Select **Dictation** or **Commands**.

For more information about Dictation and Commands, see the Input Panel Help and the Tablet PC Tutorials.

Using power management

The C5 includes a comprehensive suite of power management functions. By using the Power Options Properties window, you can control the following:

- Power schemes
- Alarms for low and critical battery
- Power meter readings for up to two batteries
- Advanced power settings
- Hibernation settings

Power Schemes

Use the Power Schemes tab to select from a set of pre-defined power schemes that are appropriate for various computing environments. You can also define your own scheme, or save one to another name that makes more sense to you.

Alarms

Use the Alarms tab to specify the point at which battery alarms are activated for the low and critically low battery level states. You can also define what happens when that battery level is reached. For example, you may choose to have the C5 sound an alarm, or you may prefer to receive a visual reminder.

Power Meter

Use the Power Meter tab to see a visual indication of the power status. If you select the **Show Details** option, you can tap a battery icon for more information.

Advanced

Use the Advanced tab to define the power-saving settings that you want to use. You can specify what you want the C5 to do when you press the Power switch.

Hibernate

Use the Hibernate tab enable or disable hibernation. This tab also shows information about the disk space used for hibernation. To use Hibernation, see “Using Hibernate” on page 31.

To manage power settings

1. Open Motion Dashboard to the Power panel (page 18).
2. Tap the **Properties** button.

The following illustration shows the Power Options Properties open to the Power Schemes tab.

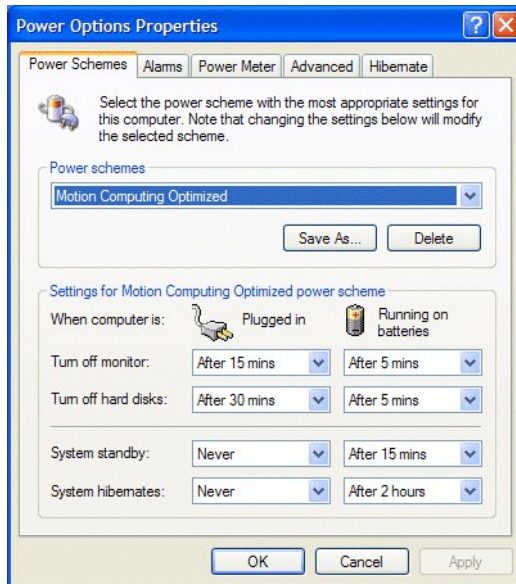

Using Standby

Standby is a state in which the display and hard disks turn off, so that the computer uses less power. When you want to use the computer again, it comes out of standby quickly, although you may have to log on again.

Use standby to save power when you will be away from the computer for a short time while working. Because Standby does not save your data to the hard disk, a power failure while on Standby can cause you to lose unsaved information.

To put the computer on Standby

1. Open Motion Dashboard to the Power panel (page 18).
2. For Power Button, select **Standby**.
3. To put the computer on Standby, press the power button.

To turn the computer back on, press the power button.

Using Hibernate

Hibernation is a state in which the computer shuts down to save power but first saves everything in memory on the hard disk. When you restart the computer, your desktop is restored exactly as you left it. Use hibernation to save power when you will be away from the computer for an extended time.

Hibernation has the following advantages over Standby:

- Hibernate saves the state of the desktop and applications.
- Hibernate consumes no battery power.
- When you return from the Hibernate state, you return to where you were when you entered hibernation.

To enable Hibernation

1. Open Motion Dashboard to the Power panel (page 18).
2. Tap the **Properties** button.
3. In the Power Options Properties window, tap the Hibernate tab.
4. Select **Enable Hibernation**.

To put the computer on Hibernate

1. Ensure that Hibernation is enabled.
2. Open Motion Dashboard to the Power panel (page 18).
3. For Power Button, select **Hibernate**.
4. To put the computer on Hibernate, press the power button.

To turn the computer back on, press the power button.

Using the battery

The Motion C5 runs on battery power when it is not plugged in. The battery is located on the back of the unit.

Checking battery power

You can check the remaining battery power from Motion Dashboard, from the battery icon in the notification area, or from the battery itself.

To check the remaining battery power

- Place the pointer over the battery icon in the notification area.

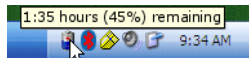

The battery icon shows a graphical representation of the remaining battery power.

You can also check the battery power from Motion Dashboard to (page 18).

To check the battery gauge

- Locate the gauge on the back of the battery and press the button.

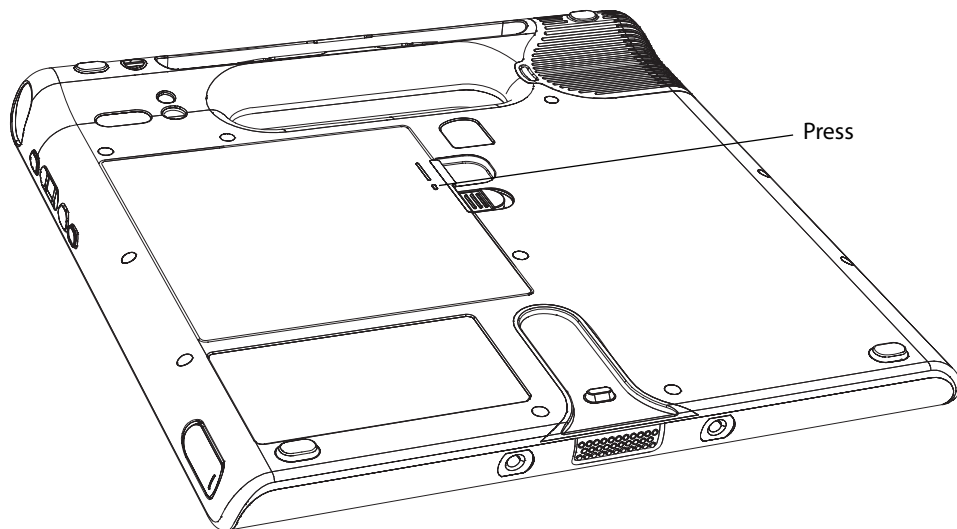

The indicator lights show the remaining charge. Each light represents approximately 20% of the total charge.

Charging the battery

When the C5 is connected to AC power, the battery automatically charges until it reaches full charge, whether the unit is on or off.

For information about the battery status light, see “Status lights” on page 8.



DANGER: To avoid injury, keep the battery within the recommended temperature range when charging it. If the battery has been subjected to extreme temperatures, wait until it cools to room temperature before recharging it. For more information, see the *Safety and Regulatory Guide* packaged with the C5.

Removing and replacing the battery

Before you remove the battery, ensure that the C5 is plugged in, turned off, or in Hibernate or Standby mode (page 31).

To remove the battery

1. With the back of the unit facing you, slide and hold the battery latch.
2. Insert your finger under the finger grip and remove the battery from the battery compartment.

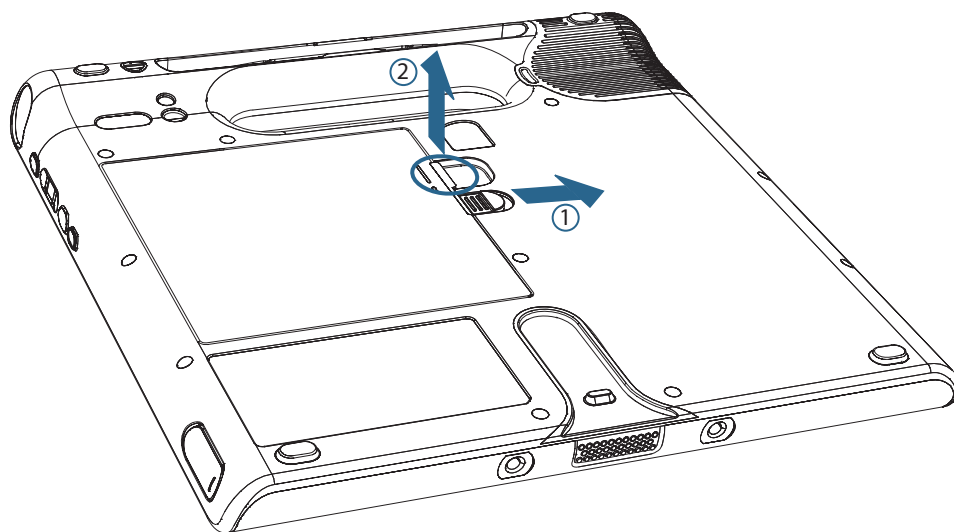

To replace the battery

1. Place the tabbed end of the battery into the battery compartment.
2. Press the battery down until it locks in to place.

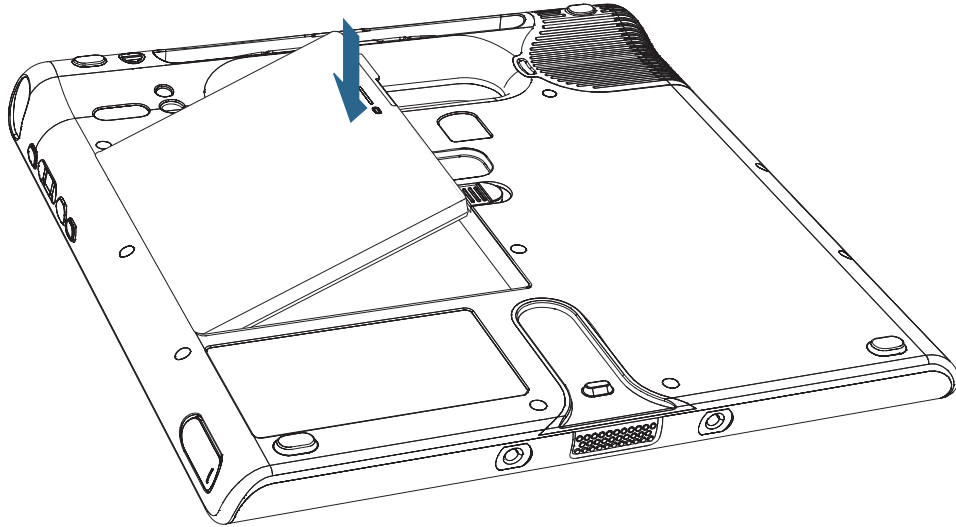

Swapping the battery

You can swap the standard battery while the system is on, with or without having the C5 plugged in to AC power.

To swap batteries

1. Put the computer in Hibernate or Standby mode (page 31).
 - With Standby, the C5 will maintain your data for up to 30 seconds while you swap the battery. You may have less than 30 seconds if you have several applications running.
 - With Hibernate, you will have as long as you need to swap the battery.
2. Remove the battery (page 33).
3. Insert the new battery (page 34).

Important: Use only Motion Computing C5 batteries with the C5.

Disposing of used batteries

A Lithium-ion (Li-ion) battery should be disposed of at a hazardous materials recycling center when it is no longer serviceable. Do not throw it in a waste receptacle because the battery could end up in a landfill.

Battery and power management tips

- To lengthen the battery's usable life, use AC power when you can. The battery will charge automatically while you run on AC power, so leave the battery in the C5 while you are working.
- Use AC power when using a CD or DVD drive.
- When running on battery power, place the system in Hibernate or Standby mode if you are going to leave it unattended for more than a few minutes (page 31).
- Remember that the display, processor, wireless cards, and accessory drives all draw on the battery, so adjust properties and disable unused accessories while running on battery power.
- When running on battery power, adjust the display brightness to a dimmer setting and enable dynamic display brightness. See "Adjusting the display brightness" on page 22.

Using Motion OmniPass and the fingerprint reader

Motion OmniPass offers a secure and convenient system for managing your passwords and providing confidentiality for your sensitive data.

To start Motion OmniPass

- In the notification area, double-tap the Motion OmniPass icon (🔑).

You can also start Motion OmniPass from the Security panel of Motion Dashboard.

The following illustration shows the Motion OmniPass Control Center.



From the OmniPass Control Center, you can manage OmniPass users and settings (distinct from Windows users), change OmniPass settings, manage passwords, and protect your files. For more information, see the OmniPass Help.

Capturing a fingerprint

After you capture your fingerprints, you can associate the fingerprints with an OmniPass user. This offers a quick and convenient way to log on to the C5, provides global password management, and helps protect your data from unauthorized access.

Use this procedure to enroll a new user and capture a fingerprint for authentication.

To capture a fingerprint

1. Start Motion OmniPass (page 36) and tap **Run Enrollment Wizard**.
2. Enter the Windows account information for the new user and tap **Next**. The fields may default to the user name of the current user.
3. If you are prompted to select an authentication device, select **Fingerprint Device**.

4. In the Choose Finger window, tap on the finger you want to enroll, then tap **Next** or **Practice**. Practice allows you to do a trial run of the fingerprint capture.

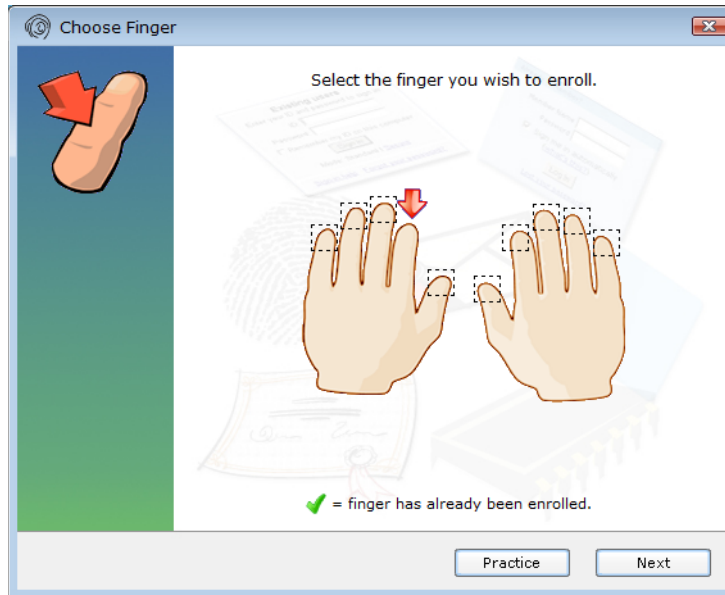

5. Place the selected finger over the fingerprint reader and slowly drag your finger across the sensor from right to left or left to right.

If the capture is successful, a green fingerprint image will appear in the capture area. If the capture is unsuccessful (red fingerprint image), follow the instructions on the screen to improve the scan.

After you have successfully captured your fingerprint, scan your fingerprint one more time for verification.

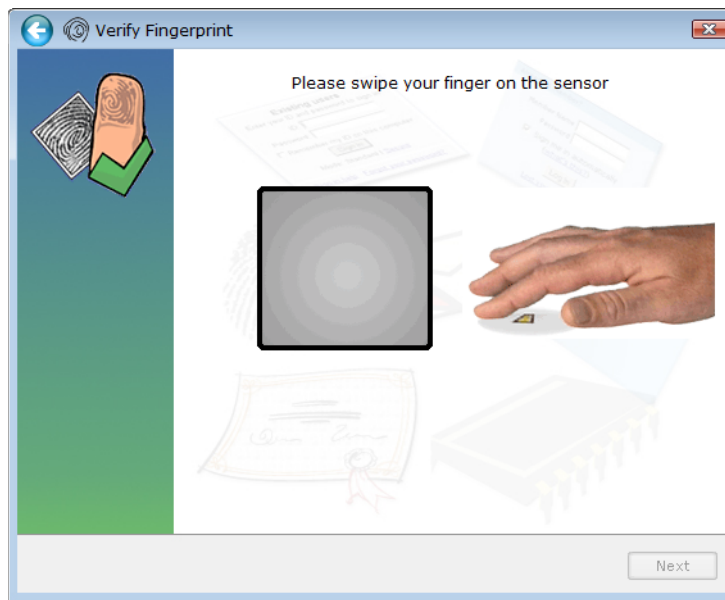

6. Tap **Next**, then tap **Yes** if you want to enroll a second fingerprint (recommended). If you injure a finger, you can use a second finger to authenticate.

You can also capture a second fingerprint later. From the OmniPass Control Center, tap **Run Enrollment Wizard**, then tap **Modify a user's device enrollment**.

7. Select **I am done with enrolling security authentication devices** and tap **Next**.
8. Select your user preferences and tap **Next**. On the Backup User Profile screen, tap **Next**.
9. Select a location for your backup profile and tap **Save**. Enter a password and tap **OK**. On the final screen, tap **Done**.

You should keep your backup profile in a secure location, such as on an external drive that you can remove and store in a secure environment.

If your profile is lost or corrupted, you can restore it later. You should back up your profile periodically to protect your configuration and any stored passwords and encryption keys. For more information, see the OmniPass Help.

Fingerprint reader tips

- Be consistent. Hold your finger and scan at the same angle each time. For example, if you enroll your finger with your hand open, hold your hand this way each time you scan.
- The scanner is bi-directional. You can move your finger from right to left or left to right.
- Read the prompts carefully and ensure that you wait for the prompt before you swipe.
- Swiping too fast or too slow can make a capture unsuccessful. Change the swipe speed until you learn what speed works best.
- When scanning, press hard enough to fully contact both the nickel-colored ring and the sensor; you do not have to press hard.
- Rub your fingers together to stimulate the natural skin oils so your fingerprint is easier to detect. Conversely, wipe your finger off so nothing interferes with the scan.
- If you are having trouble enrolling a specific finger, enroll a different finger. Typically, you should scan an index finger, thumb, middle finger, ring finger, and little finger in that order.
- If you are repeatedly having trouble getting a good scan, you may need to clean the sensor. See "Cleaning the fingerprint reader" on page 51.

Using password replacement

OmniPass can manage your passwords for other applications, such as Web sites, Internet email, FTP, or any restricted-access network resource. After OmniPass registers your credentials, you can access any of these restricted areas by using your fingerprint or the master password.

To register passwords

1. When you encounter a user name and password prompt, enter your user name and password, but do not log on. (Do not tap **Enter**, **Submit**, or **OK**.)
2. Right-click the OmniPass icon, and select **Remember Password**. The Windows arrow pointer changes to the OmniPass golden key.
3. Click the key cursor on the window that has the password that you want OmniPass to remember.

Note: For some applications, you may have to use the password wizard to register passwords. See “Using the password wizard” on page 39.

4. Enter the following information:
 - **Friendly Name.** A descriptive name to identify the password box.
 - **Automatically enter.** Instantly accesses the site without requiring a password or fingerprint scan. If you are logged in to OmniPass and you access a secure Web site, OmniPass will automatically submit your user name and password without prompting for verification.
 - **Automatically click.** Prompts you for your OmniPass/Windows password or fingerprint scan when you access the site (default).
5. Tap **Finish**.
6. If prompted, swipe your fingerprint or enter your master password to authenticate these settings.

Using the password wizard

Certain applications require more sophisticated user input for authentication. For these applications, you may need to use the password wizard to set up password replacement.

To run the password wizard

1. Start Motion OmniPass (page 36).
2. In the left pane, tap **Password Wizard**.
3. Follow the instructions in the wizard program.

Logging on to a remembered site

To log on to a remembered site, open the Web site or application that you have set up with password replacement. See “Using password replacement” on page 39. Swipe your finger or enter the master password when prompted.

To remove a remembered site, tap **Manage Passwords**.

Setting up strong logon security

For an additional level of security, you can enable strong logon security. Strong logon security forces you to authenticate with a specific security device (such as the fingerprint reader or a Smart Card) before allowing access to Windows.

After strong logon security is enabled, the Windows Welcome screen and Windows Fast User Switching are disabled.

To enable strong logon security

1. Start Motion OmniPass (page 36).
2. Tap **Change Your OmniPass Settings**.
3. Tap the **Change System Settings** tab.
4. Select the **Enable strong logon security** check box.
5. Tap **Save all changes**.
6. Tap **OK** and restart the computer.

After you restart the computer, you should configure the authentication rules for strong logon security.

To configure authentication rules

1. Start Motion OmniPass (page 36).
2. Tap **Change Your OmniPass Settings**.
3. Tap **Set user authentication rules and policies**.
4. Select the appropriate authentication rules.
5. Tap **OK**.

Using Windows Security Center

Windows Security Center provides a central location for you to manage the computer's security settings and learn more about improving security. If a problem is detected (such as an out-of-date antivirus application), the Security Center sends you an alert and provides recommendations for how to remedy the situation.



Windows Security Center manages the following:

- **Windows Firewall.** Protects the computer against viruses and other security threats, such as intruders who might try access over the Internet or a network.
- **Automatic Updates.** Keeps the computer up to date by notifying you of important Windows updates. You can configure Automatic Updates to download and install updates automatically.
- **Internet Options.** Protects you from Web sites that could damage the computer, blocks pop-ups, and protects your privacy. Internet Options allow you to change the settings of Internet Explorer, but it cannot be used to change the settings of other Web browsers.

To learn more about Windows Security Center, open Motion Dashboard to the Security panel, then tap **Windows Security Center**.

Setting up users and passwords

You can use different types of user accounts and passwords to create various levels of protection for Motion C5 and its data, depending on the level of security that you need.

Setting up Windows user accounts

You can use Windows user accounts to help secure the files on the computer from other users. You must have an administrator account on the computer to add a new user to the computer.

To set up a Windows user account

1. In Control Panel, open User Accounts.
2. Tap **Create a new account**.
3. Enter the appropriate information for the new user account.

Setting a BIOS password

You can use a BIOS password to secure the basic input/output system of the computer.



WARNING: Read this section carefully to understand the implications of creating a BIOS system password. If you forget the password, you will not be able to access the BIOS. If this happens, contact Motion Computing Technical Support at www.motioncomputing.com/support. Have the serial number ready. You can find the serial number in System Properties. To open System Properties, tap **Start** and then tap **Control Panel**. Double-tap **System**.

To set a BIOS password

1. Start the C5.
2. When the Motion Computing splash screen appears, tap the screen with the pen. On the TrustedCore menu, tap **Security Enrollment**. If you miss the splash screen, restart the computer and try again.
3. In the Security Enrollment window, enter a password using the on-screen keyboard.
4. Tap **OK**.

To clear the password, leave the password fields blank, then tap **OK**.

Setting up a hard disk drive (HDD) password

You can use a HDD password to protect the computer and the hard disk drive. The computer cannot be started without the HDD password, and the data on the disk drive cannot be accessed, even if it is removed and attached to a different computer.

To set up an HDD password

1. Start the Motion C5 (page 5).
2. When the Motion Computing splash screen appears, tap the screen with the pen. On the TrustedCore menu, tap **Launch System Setup**. If you miss the splash screen, restart the computer and try again.
3. In the PhoenixBIOS Set Up Utility, tap **Security** on the menu bar.
4. Double-tap **Enter** for **Set Hard Disk Password**.
5. Enter a password using the on-screen keyboard and tap **Enter**. Enter the password again to confirm it and tap **Enter**.
6. Tap **Exit**, then select **Exit Saving Changes**.

To clear the password, double-tap **Enter** for **Set Hard Disk Password**. Enter the current password, then tap **Enter** twice to leave the **Enter New Password** fields blank.

Using Wi-Fi (802.11a/b/g)

Use the information in this section to set up a Wi-Fi connection. Wireless access requires an 802.11a, 802.11b, or 802.11g access point. Internet access requires a working Internet connection.



DANGER: FAA regulations require that you disable any wireless connection when traveling by air. Failure to disable the wireless connection on the C5 while traveling by air can cause communications problems with aircraft instruments.

Enabling or disabling Wi-Fi

Before you can establish a Wi-Fi connection, you must enable the Wi-Fi adapter. You can enable the Wi-Fi adapter using Motion Dashboard.

To enable or disable Wi-Fi

1. Open the Motion Dashboard to the Wireless panel (page 18).
2. Select or clear the **Enable Internal 802.11 Wireless** check box.

Setting up a Wi-Fi connection

Use this procedure to create a Wi-Fi connection.

To set up a Wi-Fi connection

1. Open the Motion Dashboard to the Wireless panel (page 18).
2. Ensure that **Enable Internal 802.11 Wireless** is selected.
3. Tap the **Properties** button.
4. In the Wireless Network Connection Properties window, tap the **Wireless Networks** tab.
5. Tap **View Wireless Networks** to see a list of available networks.
6. Select the network you want to connect to and tap **Connect**. If you are connecting to a secure network, you may need to enter authentication information.

For more information about Wi-Fi, see “Wi-Fi (802.11a/b/g wireless)” on page 14.

Using Bluetooth

You can use Bluetooth® to connect to accessory devices or other computers. The devices can communicate with each other when they are in range. For more information, see “Bluetooth wireless” on page 14.

Enabling or disabling Bluetooth

Before you can set up a Bluetooth device, you must enable the Bluetooth adapter on the Motion C5. After you enable Bluetooth, the Bluetooth icon () appears in the notification area. You can tap on this icon to get shortcuts to the Bluetooth Settings window, the Bluetooth File Transfer Wizard, and the Add New Connection Wizard.

To enable or disable Bluetooth

1. Open Motion Dashboard to the Wireless panel (page 18).
2. Select or clear **Enable Internal Bluetooth Wireless**.

After you enable Bluetooth, the Bluetooth adapter tries to discover other Bluetooth devices within range. When a Bluetooth device is discoverable, it is visible to other Bluetooth devices in range. For information about making a device discoverable, see the device’s documentation.

Setting up a Bluetooth device

Before you can use a Bluetooth device with the C5, you need to set up the device. After the device is paired with the C5, a passkey is used to create a secure connection between the C5 and the Bluetooth device.

Note: Although the passkey exchange helps to secure your data, Bluetooth wireless technology should not be considered completely secure.

To set up a Bluetooth connection

1. Ensure that Bluetooth is enabled.
2. Tap **Start > All Programs > Bluetooth > Bluetooth Settings** to open the Bluetooth Settings window.
3. Place the Bluetooth device in discoverable mode. Each Bluetooth device may have a different way to make it discoverable. See the manufacturer's documentation for more information.
4. Tap the **New Connection** button.
5. In the Add New Connection window, select **Express** and tap **Next**.
6. Under Bluetooth devices, select the appropriate device and tap **Next**. If the device is not discovered, see "If the device is not discovered..." on page 46.
7. If required, enter the number shown in the Passkey field and press **Enter**. See the manufacturer's documentation for more information.
8. Enter a name for the device and tap **Next**. After the Bluetooth installation finishes, tap **Finish**.

The Bluetooth device is ready to use. Paired devices are shown in the Bluetooth Settings window. The following illustration shows a Bluetooth Settings window with a Bluetooth keyboard and mouse.

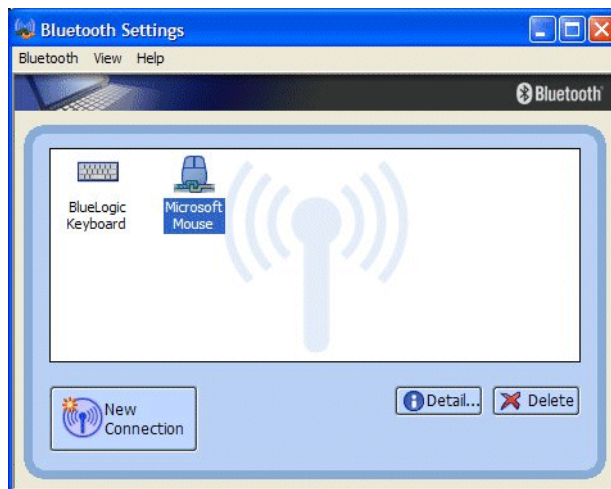

If the device is not discovered...

If the Bluetooth device is not detected after multiple attempts, try the following:

- Ensure that Bluetooth is enabled (page 44).
- Ensure that the device you are adding is discoverable. See the manufacturer's documentation for more information.
- Ensure that the Bluetooth device has good batteries.
- For keyboards, mice, and printers, ensure that you select **My device is set up and ready to be found** in the Add Bluetooth Device Wizard.
- For two computers transferring files, both computers must turn on the device transfer wizard, although only the receiving computer needs to be discoverable. Tap the Bluetooth icon and then **Send a file** or **Receive a file**. When you do this, discovery is automatically turned on for the receiving computer.
- Check which Bluetooth devices are connected. In the notification area, tap the Bluetooth icon and select **Open Bluetooth Settings**. In the Devices window, you will see the Bluetooth devices that are currently connected.

If the C5 still cannot detect the Bluetooth device, contact the device manufacturer for more information.

Bluetooth wireless tips

Motion Computing and its Bluetooth partners have worked to ensure a positive experience with this technology, and to ensure Bluetooth interoperability. In doing so, we have found the following issues:

- If you are running Bluetooth and Wi-Fi at the same time, interference can affect the Bluetooth performance. This is most noticeable when you try to transfer large amounts of data, such as transferring files or printing large documents.
- Some Bluetooth devices will disconnect when they go into power-saving mode. Most devices will automatically reconnect when they become active again.
- Occasionally, some Bluetooth device compatibility issues can occur. If you have problems with interoperability of Bluetooth devices, contact the manufacturer of the device and check its compatibility with the Bluetooth software installed on the C5.
- The Motion C5 comes with Bluetooth software from Toshiba, although you can use other Bluetooth software. For more information, go to the Motion Computing Knowledge Base at www.motioncomputing.com/kb and search for "Bluetooth".

Finding additional software

For information about other software for the Motion C5, go to the Motion Computing software page at www.motioncomputing.com/products/software_motion.asp.

You will find links to software solutions for purchase as well as free downloads from Motion software and service partners.

Care and Maintenance

4

Proper care and maintenance will keep the Motion C5 working and in good condition for a long time. This chapter describes the care and maintenance procedures for the Motion C5. For general information about care of the C5 and its components and accessories, see the *Safety and Regulatory Guide* packaged with the C5.



WARNING: Follow the guidelines listed below when caring for the Motion C5 and its components. Improper use may damage the unit and its components and void the warranty.

General care

- Protect the C5 from exposure to extreme temperatures, shock, liquids, and strong magnetic fields.
- If you are storing the C5 for a long time, unplug the power adapter and remove the battery after partially discharging it.
- Do not place heavy objects on top of the C5.
- Do not open the C5 case. Opening the case will void your warranty.

Standard display

- Clean fingerprints and most marks from the display surface by wiping it with the soft cloth (provided). Do not pour liquids directly onto the display surface itself. Do not use an abrasive cleaner on the display. If liquid is spilled on the display, wipe it up immediately. For more information, see “Cleaning in a health care environment” on page 49.
- Avoid using tissues or paper towels to clean the display surface. These contain wood fibers that can scratch the display.
- Use only the C5 pen on the display. Do not write on the display with an ink pen or pencil, or any other object that could damage the display surface.
- Protect the display surface from unnecessary contact by using a case when transporting the C5.
- Avoid exposing the display to direct sunlight for long periods of time.

View Anywhere display

- Clean fingerprints and most marks from the display surface by wiping it with the soft cloth (provided). Do not spray or pour liquids directly onto the display surface itself. Do not use an abrasive cleaner on the display. If liquid is spilled on the display, wipe it up immediately. For more information, see “Cleaning in a health care environment” on page 49.
- If needed, clean with any alcohol-based product recommended for anti-reflective glass. Other cleaning products might leave a residue.
- Avoid using tissues or paper towels to clean the display surface. These contain wood fibers that can scratch the display.
- Use only the C5 pen on the display. Do not write on the display with an ink pen or pencil, or any other object that could damage the display.
- Protect the display surface from unnecessary contact by using a case when transporting the C5.
- Avoid exposing the display to direct sunlight for long periods of time.

Cleaning in a health care environment

This section describes the cleaning procedures for the Motion C5 in a health care environment.

Disinfecting procedures

You should periodically disinfect the C5 according to the institutional policies of surface and equipment safety and cleanliness. Motion has tested a variety of antimicrobial solvents and information on specific products is available upon request.

According to the Centers for Disease Control and Prevention, “items that do not ordinarily touch the patient or touch only intact skin are not involved in disease transmission, and generally do not necessitate disinfection between uses on different patients”.¹ We recommend using an EPA-approved low-level disinfectant when general cleaning is required. For a list of cleaning solutions tested by Motion Computing, see “Cleaning solutions” on page 50.

If the C5 becomes soiled with blood or other body fluids, a hospital-approved low-level disinfectant that is tuberculocidal/virucidal when used at recommended dilutions and contact times can be used.

Visibly soiled areas should first be cleaned and then disinfected, or a detergent disinfectant can be used. For disinfection, the cleaned areas should be moistened with the appropriate germicide and allowed to air dry.²

If the C5 is used with patients who are infected or colonized with vancomycin-resistant enterococci or other drug-resistant microorganisms judged by the infection control program (based on current state, regional, or national recommendations, to be of special or clinical or epidemiologic significance or with highly virulent microorganisms such as Ebola or Lassa), then the unit should be dedicated to one patient or patient cohort or subjected to low-level cleaning between patient uses.¹

-
1. Centers for Disease Control and Prevention. “Sterilization or Disinfection of Medical Devices-General Principles.” 2002.
<www.cdc.gov/ncidod/dhqp/bp_sterilization_medDevices.html> (20 Sept. 2006).
 2. Centers for Disease Control and Prevention. “Sterilization or Disinfection of Patient-Care Equipment-HIV Related.” 2000.
<www.cdc.gov/ncidod/dhqp/bp_sterilization_patient_care.html> (20 Sept. 2006).

Training and documentation considerations

All users of portable computers in the health care environment should be provided with training on proper cleaning procedures. Cleaning procedures should be added to the institution's policies and procedures for infection prevention.

Cleaning solutions

This section describes various cleaning solutions that have been tested by Motion Computing. Review the manufacturer's guidelines for proper use of the product.

Product Type	Manufacturer	Comments
Vira-Guard	Veridien	Concentrated Isopropanol. Does not leave film.
Cavi-Wipes	Metrex	Isopropanol and Ethylene Glycol Monobutyl Ether. Leaves a slight film which needs a secondary wipe with dry cloth to remove.
Sani-Cloth	PDI	Quaternary Ammonium. Leaves a slight film which needs a secondary wipe with dry cloth to remove.

Cleaning the fan cover

If the fan cover becomes soiled, it can be removed and cleaned.

To clean the fan cover

1. Shut down the C5, unplug it, and remove the battery.
2. Turn the unit over so that the back side is facing up.
3. Press the fan cover release button.

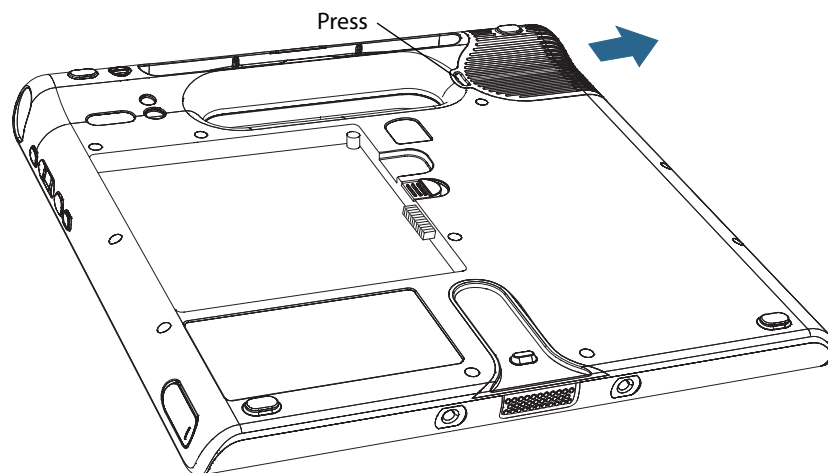

4. Slide the fan cover away from the unit to remove it.
5. Clean the fan cover according to the guidelines for your organization.
6. After the fan cover is clean and dry, slide it back onto the C5 until it snaps into place.

Cleaning the fingerprint reader

Under normal circumstances, you should clean the fingerprint reader once a month, or whenever necessary.

To clean the fingerprint reader

1. Shut down the C5, unplug it, and remove the battery.
2. Lightly spray a cotton swab with household window cleaner.
3. Gently rub the sensor surface with the cotton swab, slowly rotating the swab so a new, clean surface of the swab is constantly exposed to the sensor surface. Do not allow cleaner to drip or run down into the electronics around the sensor.

Do not use bleach, solvents, or abrasives. Do not spray or pour any liquid directly on the sensor.

4. After cleaning, gently rub the surfaces again with a clean, dry cotton swab. Use a clean swab each time you clean the sensor.

Pen

- Store the pen in the pen holder or in a case when not in use.
- Do not store the pen vertically on the tip. Constant pressure on the tip can affect the pen-to-digitizer interaction.
- Change the pen tip regularly. See “Replacing pen tips” on page 52.
- Do not immerse the pen in liquid. It contains electronic components that could be damaged.
- In certain environments, particles or debris can stick to the pen tip or the display. To avoid damaging the display, clean it frequently with the provided cleaning cloth. Also, change pen tips regularly, especially if you drop the pen onto a rough surface that could damage the tip or embed debris in it. Damaged pen tips can scratch the display.

Replacing pen tips

Pen tips eventually wear down or get damaged, so the pen includes extra tips and a tool for replacing them.

With typical use, you should change the pen tip every 90 days. If you use the pen in a dirty environment, you should change the pen tip every 30 days. Particles can become embedded in the pen tip and scratch the display.

To replace the pen tip

1. Grasp the old tip with the tip replacement tool. Use the notch on the ring to grab the tip.
2. Pull the old tip out of the pen.
3. Insert a new tip.
4. Apply slight pressure to push the tip in to place.

Ordering new pens

To order additional pens, go to the Motion Computing accessories page at www.motioncomputing.com/accessories.

Traveling with the Motion C5

Use the following tips when you travel with the C5.

- Remove all accessories and cables. Remember to pack those you will need while traveling, including at least one pen.
- Put the C5 into a case to protect the display.
- Protect the pen by keeping it in the pen holder or in a case during travel.
- Pack the C5 securely in a briefcase or hand-carried luggage, and keep it separate from toiletries, liquids, and food. Do not pack it in checked luggage.
- Keep the C5 stable during travel. Secure it to prevent it from sliding around in overhead bins and car trunks.
- Before extended use in the field or long trips away from AC power, adjust the power properties to maximize battery conservation. You can adjust the power properties from Motion Dashboard. See “Using power management” on page 29.
- For international travel, obtain and use the appropriate adapters for your destination’s electrical outlets. A current converter is not necessary.
- You may want to carry proof of ownership or a merchandise passport when traveling internationally.
- Consult your insurance company and credit card company to learn about emergency travel assistance in case the C5 becomes lost or disabled.

Traveling by air

Use the following tips when traveling by air.

- Have a fully charged battery in case security personnel ask you to start the C5.
- Have it hand-inspected or sent through the X-ray scanner, but never carry it through the metal detector.
- Turn off the C5 off or place it in hibernation mode for takeoff and landing.

FAA Wireless air travel requirement

The FAA requires that you suspend wireless operations, such as Wi-Fi and Bluetooth, before boarding a plane.



DANGER: Do not transport Li-ion batteries in checked baggage. The baggage hold can get very hot, which can overheat the Li-ion battery and result in an explosion. You can take up to two spare batteries in carry-on luggage, in addition to the one in the C5. Transporting batteries in checked baggage or transporting more than two spare batteries is a violation of federal transportation regulations.

Restoring data

You can use the Acronis True Image software to restore your computer to the state it was in when it left the factory. Additionally, you can create your own backup data archives and restore those later. For more information, see the Acronis True Image Help.

Using Acronis True Image in Windows

You can use Acronis True Image in Windows or from the boot menu. We recommend that you run Acronis True Image in Windows because the Windows version has more features.

To restore using Acronis True Image in Windows

1. Start Acronis True Image by double-tapping the Acronis True Image icon on your computer's desktop.
2. Tap **Recovery**.
3. Follow the instructions in the Restore Data Wizard. For more information, see the Acronis True Image Help.

Using Acronis Startup Recovery Manager

If you cannot start Windows, you can run Startup Recovery Manager when you start the computer. If the operating system will not start, you can use Startup Recovery Manager to restore damaged partitions.

To restore from the Startup Recovery Manager

1. Start the Motion C5 (page 5).
2. When the Acronis screen appears, press the Enter button (page 9) or the Enter key on the keyboard (optional).
3. Tap **Start Acronis True Image**.
4. Tap **Recovery**.
5. Follow the instructions in the Restore Data Wizard. For more information, see the Acronis True Image Help.

Creating a backup archive

If you want to roll back your system to a predetermined state, you can create a backup archive.

To create a backup archive

1. Start Acronis True Image by double-tapping the Acronis True Image icon on your computer's desktop.
2. Tap **Backup**.
3. Follow the instructions in the Create Backup Archive Wizard. For more information, see the Acronis True Image Help.

Creating a bootable disk

You can create a bootable recovery disk that you can use if you are ever unable to start your computer.

Note: For this procedure, you need a C5 Docking Station and an external CD+/-RW drive, DVD+/-RW drive, or USB flash drive (16 MB or larger).

To create a bootable disk

1. Start Acronis True Image by double-tapping the Acronis True Image icon on your computer's desktop.
2. Tap **Create Bootable Rescue Media**.
3. Follow the instructions in the Bootable Rescue Media Builder. For more information, see the Acronis True Image Help.

Removing the Acronis OEM Zone

The Acronis OEM Zone is a special partition on the computer's hard disk drive that stores the original factory backup archive. If you have created your own hard disk drive backup archive and a bootable disk, you can delete the OEM zone to free up some disk space.

To remove the OEM Zone

1. Start Acronis True Image by double-tapping the Acronis True Image icon on your computer's desktop.
2. Tap **Remove Acronis OEM Zone**.
3. Follow the instructions in the wizard. For more information, see the Acronis True Image Help.



WARNING: Removing the Acronis OEM Zone will disable Acronis Startup Recovery Manager and the original factory backup archive.

Troubleshooting and Support

A

Motion Computing products are thoroughly tested for performance and quality, but occasionally problems still occur. If you do not find the information you are looking for in this section, go to the Motion Computing support page at www.motioncomputing.com/support.

Troubleshooting

Use the information in this section to identify and resolve common issues. If an issue has more than one potential cause, the most common cause is listed first.

Power

The computer does not turn on

- The C5 might not be plugged in or the battery might be depleted. Plug the unit in to AC power.

The computer does not shut down

- An application might have stopped responding. Use Task Manager to manually stop the application. (Press the Windows Security button and tap the **Task Manager** button.) For more information, open Windows Help and Support and search for “task manager”. You can also hold the power switch for five seconds to force the computer to shut down.

The computer will not enter Hibernation mode.

- Hibernation might not be enabled. Use Motion Dashboard to enable Hibernation. See “Using Hibernate” on page 31.

The computer does not return from Hibernation while on battery power

- The battery might be depleted. Plug the unit in to AC power.

The display goes black while the C5 is still turned on

- The computer might have turned off the display to save power. To restore the display, touch the screen with the pen or press a button.
- The computer might have gone into Standby mode. Press and hold the power switch for about one second.
- The computer might have gone into low-battery Hibernation mode. Plug the computer in to AC power, then press and hold the power switch for about one second.

Battery

The battery does not last very long (less than three hours)

- Hot or cold conditions can adversely affect the battery charge. Use AC power if you are operating the computer in these conditions.
- Accessory devices, such as a DVD player, and applications that make heavy use of the hard drive can drain the battery more quickly.
- The battery may be weakening. Use a different battery if possible.

I lost data while swapping batteries

- The computer will maintain data and settings for 30 seconds in Standby mode. This time may vary due to the programs that are running. Try putting the computer into Hibernate mode before you swap batteries. See "Using Hibernate" on page 31.

Display

The desktop area is larger than the C5 display

- If the display resolution is set higher than the display can support, the desktop area scrolls as you move around. Decrease the display resolution so that the entire desktop is visible. For more information, open Windows Help and Support and search for "change resolution".

The display is too dim

- The brightness may be set too low. Use Motion Dashboard to increase the brightness. See "Adjusting the display brightness" on page 22.

The display is unreadable or distorted

- The screen resolution and color quality may be set incorrectly. Use Windows Display Properties to reset the display settings.
 1. In Control Panel, open Display.
 2. Tap the **Settings** tab.
 3. For **Screen resolution**, select 1024 x 768.
 4. For **Color quality**, select Highest (32 bit).

- The display driver may have been removed or become corrupted. Use Windows Device Manager to reinstall the driver.
 1. In Control Panel, open System.
 2. Tap the **Hardware** tab, then tap **Device Manager**.
 3. Expand **Display adapters**.
 4. Select the adapter and select **Action > Update driver**.
 5. Follow the instructions in the setup program.

Input

The C5 does not respond to the pen I am using

- You may be using an improper input device. Only the C5 pen can be used to write on the C5 display. The C5 does not respond to other pens or to a plastic stylus.
- You may be using the wrong C5 pen. Occasionally, a particular C5 pen may not work with a particular unit. If you are in an environment with multiple units and pens, try using a different pen. You can also tether the pen to the unit to ensure that a pen stays with it.

The pointer on the screen does not align with the pen

- The pen may need to be calibrated. See “Calibrate the digitizer” on page 5.

When I write, I inadvertently click the function button on the pen

- Adjust how you hold the pen. Avoid resting your finger on the function button. You can also use the Pen and Input Devices window to disable the button. See “Configuring pen options” on page 19.

The function button does not work

- The function button may not be enabled. You can use Tablet and Pen Settings window to enable the function button. See “Configuring pen options” on page 19.
- You may not be pressing the button early enough. Try pressing the function button before you touch the pen to the display surface.

The eraser does not work

- The eraser may not be enabled. You can use Tablet and Pen Settings window to enable the eraser. See “Configuring pen options” on page 19. The eraser works on digital ink only, not text.

The buttons on the C5 do not do what I expect them to do

- The button functions may have been customized. You can use the Tablet and Pen Settings window to change the buttons to the desired functions. See “Configuring front panel buttons” on page 21.

Ports and connectors

The C5 is in the docking station, but the system does not recognize any accessory devices, such as the external disk drive or monitor

- The C5 may not be fully seated in the docking station. Remove the unit from the docking station and then replace it.

Network

The wireless adapter keeps connecting even when I do not want it to

- The wireless adapter is enabled. You can use Motion Dashboard to disable the wireless adapter. See “Enabling or disabling Wi-Fi” on page 43.

Audio

No sound is coming from the speakers

- The volume may be set too low or muted. You can use Motion Dashboard to increase the volume or turn mute off.
- The integrated audio components may have been overwritten. If you install a third-party audio device (such as a USB or Bluetooth device), the integrated audio may stop working. If this happens, reinstall the SigmaTel and Knowles Acoustics audio drivers. If you still have problems after reinstalling the drivers, contact Motion Technical Support.

System

I forgot my BIOS password and cannot access my computer

- You can enter several incorrect passwords before the BIOS temporarily locks the system. You can try again by restarting the system. If you still cannot log on, contact Motion Computing Technical Support at www.motioncomputing.com/support.

An application has stopped responding, but I can still move the pointer and use other applications

- Use Task Manager to manually stop the application. (Press the Windows Security button and tap Task Manager.) See Windows Help and Support for more information.

The computer seems to be operating more slowly than usual

- The hard disk drive may be full or nearly full. You can use Disk Cleanup to free up space on the hard drive. For more information, open Windows Help and Support and search for “disk cleanup”.
- The hard disk may need to be defragmented. You can use Disk Defragmenter to consolidate files and folders on the hard drive. For more information, open Windows Help and Support and search for “disk defragmenter”.

Frequently asked questions

How can I make the battery charge last longer?

- For maximum conservation, you can use the **Max Battery** power scheme. To select this scheme, open Motion Dashboard to the Power panel.
- Set the display brightness to the dimmest level you are comfortable with. See “Adjusting the display brightness” on page 22.
- Disable the wireless adapter and Bluetooth adapter if you are not using them.
- Stop unnecessary background applications and processes.

What do I need to use the Motion C5 in another country?

- You will need a travel plug adapter. You can find these in airports and travel stores. You do not need to buy a voltage converter; the Motion AC adapter will automatically adjust to different voltages.

How do I clean the standard display screen?

- To clean the acrylic display screen, wipe it with a soft cloth (like the one supplied) onto which you have sprayed a window-type cleaner. Do not spray cleaners, spray or pour any liquid, nor wipe any abrasive cleaner on the screen nor any surface of the C5. Do not use tissues or paper towels to clean the screen. They contain wood fibers and may scratch the surface.

How do I clean the View Anywhere display screen?

- To clean the View Anywhere display screen, wipe it with a soft cloth (like the one supplied). If needed, clean with any alcohol-based product recommended for use on anti-reflective glass. Other cleaning products may leave a residue. Do not spray cleaners, spray or pour any liquid, nor wipe any abrasive cleaner on the screen nor any surface of the C5. Do not use tissues or paper towels to clean the screen. They contain wood fibers and may scratch the surface.

Will scratches affect the performance of the display or digitizer?

- Our testing has not found appreciable loss of performance on a scratched display.

How sensitive is the screen to various elements?

- As with any computer or electronic device, you should protect it from liquids, dirt and sand, other contaminants, and extreme heat.

Will any monitor, USB device, keyboard, or mouse work with the C5?

- If the device has a driver for Windows, it will work with the C5. For a list of products that have been tested for Windows, go to the Windows Marketplace Tested Products page at www.microsoft.com/whdc/hcl.

Why is the C5 lacking USB and display adapter ports?

- The C5 is designed to be easy to clean and disinfect, so ports and connectors are minimized.

How do I adjust the C5 for left-handed use?

- Open the Tablet and Pen Settings window (page 19). You can select left- or right-handed and change the location of the menus. You should calibrate the pen if you change any pen options (page 5).

Specifications

You can use System Information to find out more about your hardware and software environment. From the Start menu, choose **All Programs > Accessories > System Tools > System Information**.

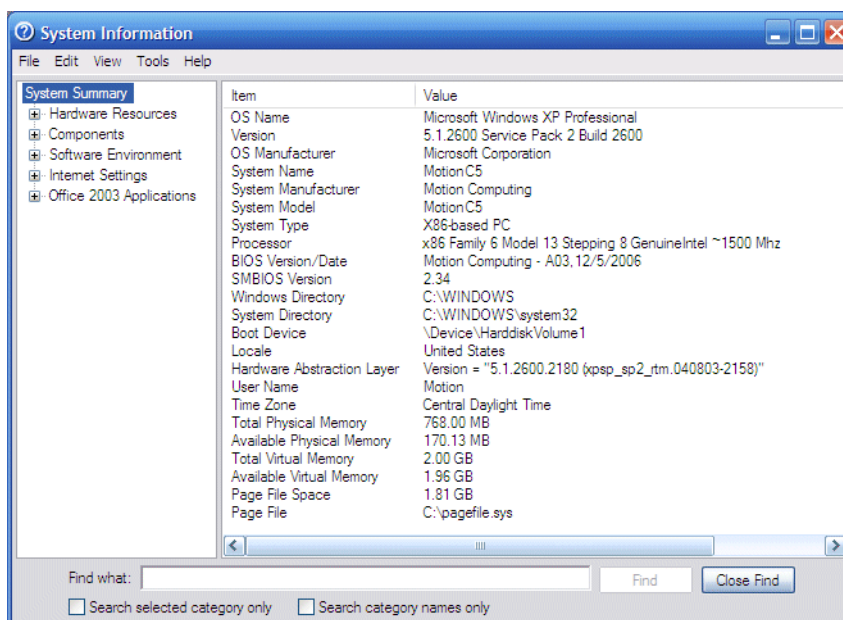

You can find the specifications for other Motion Computing products at www.motioncomputing.com/products.

Warranty and insurance programs

Motion Computing currently provides limited warranties on Motion products and accessories. See the Warranty packaged with your Motion product or accessory or visit our Web site at www.motioncomputing.com.

In addition, Motion Computing offers extended warranties along with various screen and configuration insurance programs. Go to the Motion Computing Support and Services page at www.motioncomputing.com/support.

Service and support

If you need help with the Motion C5, go to the Motion Computing Support and Services page at www.motioncomputing.com/support.

This page will provide you links to all the information you need about Motion products, technical support, customer services and professional services.

