

FBKR18 & FBKR18 Series

Gas Rethermalizers

Installation, Operation, Service, and Parts Manual

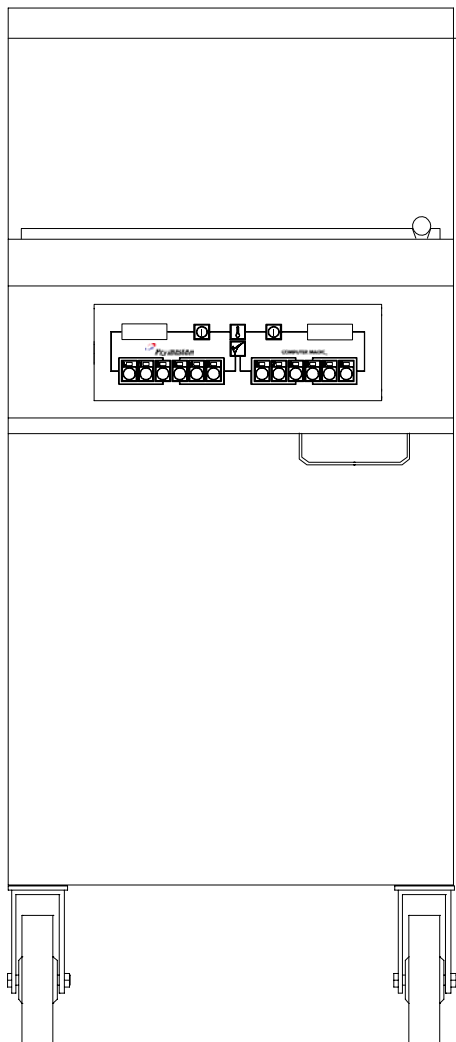

 **Frymaster**[®]

CFESA
Commercial Food Equipment Service Association

Frymaster, a member of the Commercial Food Equipment Service Association, recommends using CFESA Certified Technicians.

24-Hour Service Hotline 1-800-551-8633

**819-5686
March 2005**

NOTICE

IF, DURING THE WARRANTY PERIOD, THE CUSTOMER USES A PART FOR THIS ENODIS EQUIPMENT OTHER THAN AN **UNMODIFIED** NEW OR RECYCLED PART PURCHASED DIRECTLY FROM FRYMASTER/DEAN, OR ANY OF ITS AUTHORIZED SERVICE CENTERS, AND/OR THE PART BEING USED IS MODIFIED FROM ITS ORIGINAL CONFIGURATION, THIS WARRANTY WILL BE VOID. FURTHER, FRYMASTER/DEAN AND ITS AFFILIATES WILL NOT BE LIABLE FOR ANY CLAIMS, DAMAGES OR EXPENSES INCURRED BY THE CUSTOMER WHICH ARISE DIRECTLY OR INDIRECTLY, IN WHOLE OR IN PART, DUE TO THE INSTALLATION OF ANY MODIFIED PART AND/OR PART RECEIVED FROM AN UNAUTHORIZED SERVICE CENTER.

NOTICE

This appliance is intended for professional use only and is to be operated by qualified personnel only. A Frymaster/DEAN Factory Authorized Service Center (FASC) or other qualified professional should perform installation, maintenance, and repairs. Installation, maintenance, or repairs by unqualified personnel may void the manufacturer's warranty. See Chapter 1 of this manual for definitions of qualified personnel.

NOTICE

This equipment must be installed in accordance with the appropriate national and local codes of the country and/or region in which the appliance is installed. See **NATIONAL CODE REQUIREMENTS** in Chapter 2 of this manual for specifics.

NOTICE TO U.S. CUSTOMERS

This equipment is to be installed in compliance with the basic plumbing code of the Building Officials and Code Administrators International, Inc. (BOCA) and the Food Service Sanitation Manual of the U.S. Food and Drug Administration.

NOTICE

Drawings and photos used in this manual are intended to illustrate operational, cleaning and technical procedures and may not conform to onsite management operational procedures.

NOTICE TO OWNERS OF UNITS EQUIPPED WITH COMPUTERS

U.S.

This device complies with Part 15 of the FCC rules. Operation is subject to the following two conditions: 1) This device may not cause harmful interference, and 2) This device must accept any interference received, including interference that may cause undesired operation. While this device is a verified Class A device, it has been shown to meet the Class B limits.

CANADA

This digital apparatus does not exceed the Class A or B limits for radio noise emissions as set out by the ICES-003 standard of the Canadian Department of Communications.

Cet appareil numerique n'emet pas de bruits radioelectriques depassany les limites de classe A et B prescrites dans la norme NMB-003 edictee par le Ministre des Communcations du Canada.

 DANGER

Improper installation, adjustment, maintenance or service, and unauthorized alterations or modifications can cause property damage, injury, or death. Read the installation, operating, and service instructions thoroughly before installing or servicing this equipment. Only qualified service personnel may convert this appliance to use a gas other than that for which it was originally configured. See Chapter 1 of this manual for definition of qualified service personnel.

⚠ DANGER

No structural material on the rethermalizer should be altered or removed to accommodate placement of the rethermalizer under a hood. Questions? Call the Frymaster/Dean Service Hotline at 1-800-551-8633.

⚠ DANGER

Adequate means must be provided to limit the movement of this appliance without depending upon the gas line connection. Single rethermalizers equipped with legs must be stabilized by installing anchor straps. All rethermalizers equipped with casters must be stabilized by installing restraining chains. If a flexible gas line is used, an additional restraining cable must be connected at all times when the rethermalizer is in use.

⚠ DANGER

The front ledge of the rethermalizer is not a step! Do not stand on the rethermalizer. Serious injury can result from slips or contact with the hot water.

⚠ DANGER

Do not store or use gasoline or other flammable liquids or vapors in the vicinity of this or any other appliance.

⚠ DANGER

Instructions to be followed in the event the operator smells gas or otherwise detects a gas leak must be posted in a prominent location. This information can be obtained from the local gas company or gas supplier.

⚠ DANGER

This product contains chemicals known to the State of California to cause cancer and/or birth defects or other reproductive harm.

Operation, installation, and servicing of this product could expose you to airborne particles of glasswool or ceramic fibers, crystalline silica, and/or carbon monoxide. Inhalation of airborne particles of glasswool or ceramic fibers is known to the State of California to cause cancer. Inhalation of carbon monoxide is known to the State of California to cause birth defects or other reproductive harm.

NOTICE

The Commonwealth of Massachusetts requires any and all gas products to be installed by a licensed plumber or pipe fitter.

FBCR18 & FBKR18 SERIES GAS RETHERMALIZERS

TABLE OF CONTENTS

CHAPTER 1: General Information

| | | |
|-----|--|-----|
| 1.1 | Parts Ordering and Service Information | 1-1 |
| 1.2 | Safety Information | 1-1 |
| 1.3 | Equipment Description | 1-2 |
| 1.4 | Installation, Operating, and Service Personnel | 1-2 |
| 1.5 | Definitions | 1-2 |
| 1.6 | Shipping Damage Claim Procedure | 1-3 |

CHAPTER 2: Installation Instructions

| | | |
|-----|---|-----|
| 2.1 | General Installation Requirements | 2-1 |
| 2.2 | Caster/Leg Installation | 2-2 |
| 2.3 | Pre-Connection Preparations | 2-2 |
| 2.4 | Connecting to the Gas Supply | 2-4 |
| 2.5 | Converting to Another Gas Type | 2-5 |

CHAPTER 3: Operating Instructions

| | | |
|-----|---|-----|
| 3.1 | Introduction | 3-1 |
| 3.2 | FBCR18 Series Computer | 3-1 |
| | Programming the FBCR18 Series Computer | 3-2 |
| | Operating the FBCR18 Series Rethermalizer | 3-2 |
| | Using the FBCR18 Chill Feature | 3-3 |
| | FBCR18 Temperature Display Options | 3-3 |
| | FBCR18 Computer Display Messages | 3-3 |
| 3.3 | FBKR18 Series Computer | 3-3 |
| | Programming the FBKR18 Series Computer | 3-4 |
| | Operating the FBKR18 Series Rethermalizer | 3-6 |
| | FBKR18 Temperature Display Options | 3-7 |
| | FBKR18 Computer Display Messages | 3-7 |
| | FBKR18 Boil or Simmer Mode Options | 3-7 |
| | FBKR18 Clock Speed Options | 3-7 |
| 3.4 | Start-Up Procedure | 3-8 |
| 3.5 | Boiling Out the Cookpot | 3-9 |
| 3.6 | Shutting the Rethermalizer Down | 3-9 |

CHAPTER 4: Preventive Maintenance

| | | |
|-----|---------------------------------------|-----|
| 4.1 | Daily Checks and Services | 4-1 |
| 4.2 | Quarterly Checks and Services | 4-1 |
| 4.3 | Semi-Annual Checks and Services | 4-2 |
| | Clean Combustion Air Blower | 4-2 |
| | Clean Gas Valve Vent Tube | 4-2 |
| | Check Burner Manifold Pressure | 4-3 |

CHAPTER 5: Operator Troubleshooting

| | | |
|-----|---|-----|
| 5.1 | Introduction | 5-1 |
| 5.2 | Operator Troubleshooting Guides | 5-2 |
| 5.3 | Replacing the Computer or Computer Wiring Harness | 5-6 |

CHAPTER 6: Service Procedures

| | | |
|-------|---|------|
| 6.1 | Functional Description | 6-1 |
| | The Electronic Ignition System | 6-1 |
| | Computers | 6-2 |
| | Interface Board | 6-2 |
| | Temperature Probe | 6-3 |
| | Water Level Sensors | 6-3 |
| 6.2 | Accessing the Rethermalizer for Servicing | 6-3 |
| 6.3 | Cleaning the Gas Valve Vent Tube | 6-6 |
| 6.4 | Checking the Burner Manifold Gas Pressure | 6-4 |
| 6.5 | Measuring Flame Current | 6-4 |
| 6.6 | Replacing Components | 6-4 |
| 6.6.1 | Replacing the Computer or Computer Wiring Harness | 6-4 |
| 6.6.2 | Replacing the Temperature Probe | 6-4 |
| 6.6.3 | Replacing the Interface Board | 6-5 |
| 6.6.4 | Replacing an Ignition Module | 6-5 |
| 6.6.5 | Replacing an Ignitor Assembly | 6-6 |
| 6.6.6 | Replacing the Combustion Air Blower | 6-6 |
| 6.6.7 | Replacing the Gas Valve | 6-6 |
| 6.6.8 | Replacing a Burner Assembly | 6-7 |
| 6.6.9 | Replacing the Cookpot | 6-7 |
| 6.7 | Troubleshooting and Problem Isolation | 6-8 |
| 6.7.1 | Ignition Failures | 6-9 |
| 6.7.2 | Improper Burner Functioning | 6-9 |
| 6.7.3 | Improper Temperature Control | 6-11 |
| 6.7.4 | Computer-Related Problems | 6-12 |
| 6.8 | Troubleshooting Guides | 6-12 |
| 6.8.1 | Troubleshooting the Gas Valve | 6-13 |
| 6.8.2 | Troubleshooting the 24 VAC Circuit | 6-14 |
| 6.8.3 | Troubleshooting the Temperature Probe | 6-16 |
| | Probe Resistance Chart | 6-17 |
| 6.9 | Simplified Wiring Diagrams | 6-18 |

CHAPTER 7: Parts List

| | | |
|-----|--|-----|
| 7.1 | Burner System Components | 7-1 |
| 7.2 | Cabinetry and Associated Components | 7-2 |
| 7.3 | Computer, Component Box Assembly, and Associated Parts | 7-3 |
| 7.4 | Cookpot and Associated Parts | 7-4 |
| 7.5 | Gas Supply Components | 7-5 |
| 7.6 | Plumbing Components | 7-6 |

FBCR18 & FBKR18 SERIES GAS RETHERMALIZERS

CHAPTER 1: GENERAL INFORMATION

1.1 Applicability and Validity

This manual is applicable to and valid for all FBCR18 and FBKR18 units sold in English-speaking countries. Where conflicts exist between instructions and information in this manual and local or national codes of the country in which the equipment is installed, installation and operation shall comply with those codes.

This appliance is only for professional use and shall be used by qualified personnel only, as defined in Section 1.6.

1.2 Parts Ordering and Service Information

In order to assist you as quickly as possible, the Frymaster Factory Authorized Service Center (FASC) or Service Department representative requires certain information about your equipment. Most of this information is printed on a data plate affixed to the inside of the door.

Parts orders may be placed directly with your local FASC or distributor. Included with the unit when shipped from the factory is a list of FASCs. If you do not have access to this list, contact the Frymaster Technical Service Department at 1-800-551-8633 or 1-318-865-1711.

When ordering parts, the following information is required:

Model Number: _____
Serial Number: _____
Gas Type: _____
Item Part Number: _____
Quantity Needed: _____

Service information may be obtained by contacting your local FASC/Distributor. Information may also be obtained by calling the Frymaster Technical Service Department at 1-800-551-8633 or 1-318-865-1711. When requesting service, please have the following information ready:

Model Number: _____
Serial Number: _____
Gas Type: _____

In addition to the model number, serial number, and gas type, please be prepared to describe the nature of the problem and have ready any other information that you think may be helpful in solving your problem.

RETAIN AND STORE THIS MANUAL IN A SAFE PLACE FOR FUTURE USE.

1.3 Safety Information

Before attempting to operate your unit, read the instructions in this manual thoroughly.

Throughout this manual, you will find safety notations enclosed in double-bordered boxes similar to the one below.

 **DANGER**

DANGER boxes contain information about actions or conditions that *may cause or result in injury to personnel*, and which may cause damage to your system and/or cause your system to malfunction.

 **CAUTION** boxes contain information about actions or conditions that *may cause or result in a malfunction of your system*.

 **WARNING** boxes contain information about actions or conditions that *may cause or result in damage to your system*, and which may cause your system to malfunction.

 **DANGER** boxes contain information about actions or conditions that *may cause or result in injury to personnel*, and which may cause damage to your system and/or cause your system to malfunction.

1.4 Equipment Description

The FBCR18 and FBKR18 Series Gas Rethermalizers are specifically designed to rethermalize meats, sauces, and other vacuum packaged foods at a safe temperature range that prevents overcooking. They can be configured for either natural or LP (Propane) gas, and their efficient infrared burners deliver 90,000 BTUs (94.9 MJ – 26.4 kW).

The systems feature programmable computer controls and an easy to clean automatically filled cookpots. The FBKR18 also has a manual-fill switch. Each unit can rethermalize up to 15 lbs. (7kg) of food an hour.

The rethermalizers are safeguarded against boil-over by a standpipe overflow drain, and come with a 1¼” cookpot drain for fast, clog-free emptying. The unit has a rethermalizing area of 18” x 24” (457mm x 609mm) and holds 25 gallons (94.6 liters) of water.

1.5 Installation, Operating, and Service Personnel

Operating information for Frymaster equipment has been prepared for use by qualified and/or authorized personnel only, as defined in Section 1.5.

All installation and service on Frymaster equipment must be performed by qualified, certified, licensed, and or/authorized installation or service personnel, as defined in Section 1.6.

1.6 Definitions

QUALIFIED AND/OR AUTHORIZED OPERATING PERSONNEL

Qualified/authorized operating personnel are those who have carefully read the information in this manual and have familiarized themselves with the equipment functions, or who have had previous experience with the operation of the equipment covered in this manual.

QUALIFIED INSTALLATION PERSONNEL

Qualified installation personnel are individuals, or firms, corporations, or companies which, either in person or through a representative, are engaged in and are responsible for the installation of electrical and gas appliances. Qualified personnel must be experienced in such work, be familiar with all electrical precautions involved, and have complied with all requirements of applicable national and local codes.

QUALIFIED SERVICE PERSONNEL

Qualified service personnel are those that are familiar with Frymaster equipment and who have been authorized by Frymaster to perform service on Frymaster equipment. All authorized service personnel are required to be equipped with a complete set of service and parts manuals, and to stock a prescribed minimum amount of Frymaster equipment parts.

A list of Frymaster Factory Authorized Service Centers (FASC) was included with the unit when it was shipped from the factory. *Failure to use qualified service personnel will void the Frymaster Warranty on your equipment.*

1.7 Shipping Damage Claim Procedure

Your Frymaster equipment was carefully inspected and packed before leaving the factory. The transportation company assumes full responsibility for safe delivery upon acceptance of the equipment for transport.

What to do if your equipment arrives damaged:

1. **File a claim for damages immediately**, regardless of the extent of damages.
2. **Inspect for and record all visible loss or damage** and ensure that this information is noted on the freight bill or express receipt and is signed by the person making the delivery.
3. **Concealed loss or damage** that was unnoticed until the equipment was unpacked should be recorded and reported to the freight company or carrier **immediately** upon discovery. A concealed damage claim must be submitted within 15 days of the date of delivery. Ensure that the shipping container is retained for inspection.

**FRYMASTER DOES NOT ASSUME RESPONSIBILITY
FOR DAMAGE OR LOSS INCURRED IN TRANSIT.**

FBCR18 & FBKR18 SERIES GAS RETHERMALIZERS

CHAPTER 2: INSTALLATION INSTRUCTIONS

2.1 General Installation Requirements

Qualified, licensed, and/or authorized installation or service personnel, as defined in Section 1.6 of this manual, should perform all installation and service on Frymaster equipment.

Conversion of this appliance from one type of gas to another should only be performed by qualified, licensed, and/or authorized installation or service personnel as defined in Section 1.6 of this manual.

Failure to use qualified, licensed, and/or authorized installation or service personnel (as defined in Section 1.6 of this manual) to install, convert to another gas type or otherwise service this equipment will void the Frymaster warranty and may result in damage to the equipment or injury to personnel.

Where conflicts exist between instructions and information in this manual and local or national codes or regulations, installation and operation shall comply with the codes or regulations in force in the country in which the equipment is installed.

Upon arrival, inspect the rethermalizer carefully for visible or concealed damage. (See **Shipping Damage Claim Procedure** in Chapter 1.)

WARNING

Frymaster appliances equipped with legs are for stationary installations. Appliances fitted with legs must be lifted during movement to avoid damage to the appliance and bodily injury. For movable installations, optional equipment casters must be used. Questions? Call 1-800-551-8633.

CLEARANCE AND VENTILATION

DANGER

No structural material on this appliance should be altered or removed to accommodate placement of the appliance under a hood. Questions? Call the Frymaster/Dean Service Hotline at 1-800-551-8633.

DANGER

This appliance must be installed with sufficient ventilation to prevent the occurrence of unacceptable concentrations of substances harmful to the health of personnel in the room in which it is installed.

This equipment must be installed with a 6" (150mm) clearance at both sides and back when installed adjacent to combustible construction. No clearance is required when installed adjacent to noncombustible construction. A minimum of 24" (600mm) clearance should be provided at the front of the unit.

One of the most important considerations of efficient operation is ventilation. Make sure the equipment is installed so that products of combustion are removed efficiently, and that the kitchen ventilation system does not produce drafts that interfere with proper burner operation.

The equipment flue opening must not be placed close to the intake of the exhaust fan, and the flue must never be extended in a “chimney” fashion. An extended flue will change the combustion characteristics of the equipment, causing longer recovery times. It also frequently causes delayed ignition. To provide the airflow necessary for good combustion and burner operation, the areas surrounding the front, sides, and rear of the unit must be kept clear and unobstructed.

This equipment must be installed in an area with an adequate air supply and adequate ventilation. For U.S installations, information on construction and installation of ventilating hoods can be found in NFPA Standard 96. This document can be ordered from the National Fire Protection Association, Battery March Park, Quincy, MA 02269. For installations in countries other than the U.S., the appropriate regulating authority should be contacted for information related to hood construction and installation.

 DANGER

Do not attach an apron drain to a single rethermalizer. The rethermalizer may become unstable, tip over, and cause injury to personnel.

NATIONAL CODE REQUIREMENTS

This equipment is to be installed in compliance with the Basic Plumbing Code of the Building Officials and Code Administrators International, Inc. (BOCA) and the Food Service Sanitation Manual of the U.S. Food and Drug Administration.

This equipment is manufactured to use the type of gas specified on the rating plate attached to the door. Connect equipment stamped “NAT” only to natural gas and that stamped “PRO” only to LP (Propane) gas.

Installation shall be made with a gas connector that complies with national and local codes. Quick disconnect devices, if used, shall likewise comply with national and local codes.

ELECTRICAL GROUNDING REQUIREMENTS

 DANGER

This appliance is equipped with a three-prong (grounding) plug for your protection against electrical shock, and must be plugged directly into a properly grounded three-prong receptacle. Do not cut, remove, or otherwise bypass the grounding prong on this plug!

 DANGER

This appliance requires electrical power for operation. Place the gas control valve in the OFF position in case of a prolonged power outage. Do not attempt to operate this appliance during a power outage.

All electrically operated appliances must be grounded in accordance with all applicable national and local codes. A wiring diagram is located on the inside of the door. In the United States and Canada, the electrical supply must be 120VAC, 60 Hz. In other countries, refer to the rating plate on the inside of the door for proper voltages.

FCC COMPLIANCE

The user is cautioned that any changes or modifications to Frymaster computers not expressly approved by the party responsible for compliance could void the user's authority to operate the equipment. Frymaster computers have been tested and found to comply with the limits for a Class A digital device, pursuant to Part 15 of the FCC rules. While these devices are verified as Class A devices, they have been shown to meet the Class B limits. These limits are designed to provide reasonable protection against harmful interference when the equipment is operated in a commercial environment. This equipment generates, uses, and can radiate radio frequency energy and, if not installed and used in accordance with the instruction manual, may cause harmful interference to radio communications. Operation of the equipment in a residential area is likely to cause harmful interference in which case the user will be required to correct the interference at his own expense. If necessary, the user should consult the dealer or an experienced radio and television technician for additional suggestions.

The user may find the booklet "How to Identify and Resolve Radio-TV Interference Problems" helpful. It is prepared by the Federal Communications Commission and is available from the U.S. Government Printing Office, Washington, DC 20402, Stock No. 004-000-00345-4.

2.2 Caster/Leg Installation

Depending upon the specific configuration ordered, your unit may have been shipped without installed casters or legs. If casters or legs are installed, you may skip this section and proceed to Section 2.3, Pre-Connection Preparations.

If your unit requires the installation of casters/legs, install them in accordance with the instructions included in your accessory package.

2.3 Pre-Connection Preparations

 **DANGER**

Do not connect this equipment to the gas supply before completing each step in this section.

After the unit has been positioned in the area where it will be used, ensure the following has been accomplished before connecting the unit to the gas supply:

1. Adequate means must be provided to limit the movement of this equipment without depending upon the gas line connections. If a flexible gas hose is used, a restraining cable must be connected at all times when the equipment is in use. The restraining cable and installation instructions are packed with the flexible hose in the accessories box that was shipped with your unit.

2. The rethermalizer must be stabilized by installing restraining chains on units equipped with casters or anchor straps on units equipped with legs. Follow the instructions shipped with the casters/legs to properly install the chains or straps.
3. Level rethermalizers equipped with legs by screwing out the legs approximately 1 inch then adjusting them so that the rethermalizer is level.
4. For rethermalizers equipped with casters, there are no built-in leveling devices. The floor where the rethermalizer is to be installed must be level.

⚠ DANGER

Do not attach an apron drain board to this unit. The appliance may become unstable, tip over, and cause injury. The appliance area must be free and clear of combustible material at all times.

5. Connect the water hose to the fitting at the rear of the unit.

NOTE 1: The hose comes with a quick-disconnect coupling. The quick disconnect may be attached to the rethermalizer or to the water supply line, or it may be left off entirely, whichever you prefer. Whichever of the options is chosen, Teflon thread-seal tape or Loctite™ PST56765 or equivalent thread sealer must be used when installing the fittings.

NOTE 2: Either hot or cold water may be connected to the unit. Connecting to hot water will minimize the amount of time required to bring the unit to boil when filling with fresh water. However, on FBCR18 units, connecting to hot water will lower the efficiency of the chill feature.

NOTE 3: In order for the water level sensors to work properly, a certain amount of mineral content is necessary in the water. For that reason, purified, deionized, or highly filtered water should not be used.

4. Connect the desired drain plumbing to the 1¼” drain valve.
5. Test the equipment electrical system by plugging the power cord into a grounded 120VAC outlet and pressing the computer’s ON/OFF button. **Lo** or **cyCl** should appear in the display.
6. Turn the computer off. Verify that the display is blank.
7. Verify that the minimum and maximum incoming gas pressures for the type of gas to be used are in accordance with the accompanying table.

| Incoming Gas Pressures | | |
|-------------------------------|----------------|----------------|
| Gas | Minimum | Maximum |
| Natural | 6" W.C. | 14" W.C. |
| | 1.49 kPa | 3.48 kPa |
| | 14.93 mbar | 34.84 mbar |
| LP | 11" W.C. | 14" W.C. |
| | 2.74 kPa | 3.48 kPa |
| | 27.37 mbar | 34.84 mbar |

2.4 Connecting to the Gas Supply

 **DANGER**

Before connecting new pipe to this appliance, the pipe must be blown out thoroughly to remove all foreign material. Foreign material in the burner and gas controls will cause improper and dangerous operation.

 **DANGER**

When pressure-testing incoming gas supply lines, disconnect the appliance from the gas line if the test pressure will be $\frac{1}{2}$ PSIG (3.45 kPa, 13.84 inches W.C.) or greater to avoid damage to the appliance's gas tubes and gas valve(s).

 **DANGER**

All connections must be sealed with a joint compound suitable for the gas being used and all connections must be tested with a solution of soapy water before lighting any pilots.

Never use matches, candles, or any other ignition source to check for leaks. If gas odors are detected, shut off the gas supply to the appliance at the main shut-off valve and immediately contact the local gas company or an authorized service agency for service.

 **DANGER**

“Dry-firing” your unit will cause damage to the cookpot. Always ensure that water is in the cookpot before firing the unit.

GAS CONNECTIONS AND PIPE SIZES

The size of the gas supply pipe is very important. If the pipe is too small, the gas pressure at the burner manifold will be low. This will cause slow recovery and delayed ignition. The incoming gas supply line should be a minimum of $1\frac{1}{2}$ inches (38mm) ID.

When configured for natural gas, this equipment requires a standard gas pipe size of $\frac{3}{4}$ inch (19mm) ID for connections within 20 feet (6m) of the supply line, provided no more than 4 fittings or elbows are used in the run. For a pipe run over 20 feet (6m), increase the pipe size to 1 inch (25.4mm). For use with LP (Propane) gas, the next smaller pipe size may be used.

IF IN DOUBT ABOUT THE PIPE SIZE TO BE USED, CONSULT YOUR LOCAL GAS COMPANY.

1. Connect the equipment to the gas supply line.

When making connections, apply a small amount of Loctite[®] PST 56765 or equivalent thread compound to the male threads only. **DO NOT** apply the compound to the first two threads. This will prevent clogging of the burner orifices and control valve.

2. Open the gas supply to the fryer and check all piping, fittings, and gas connections for leaks. A soap and water solution should be used for this purpose.
3. Close the drain valve and fill the cookpot with water and boil-out solution to the overflow. Light the burners and perform the boil-out procedures that are described in the “Start-Up Procedure” and “Boiling Out the Cookpot” sections in Chapter 3 of this manual.
4. It is suggested that the burner manifold pressure be checked at this time by the local gas company or an authorized service agent. Refer to “Check Burner Manifold Pressure” in Chapter 4 of this manual for the proper procedure.

2.5 Converting to Another Gas Type

This equipment is configured at the factory for either natural gas or LP (Propane) gas.

If you desire to switch from one type of gas to the other, a gas conversion kit must be installed by a Factory Authorized Service Center technician.

DANGER

This appliance was configured at the factory for a specific type of gas. Converting from one type of gas to another requires the installation of specific gas-conversion components.

Switching to a different type of gas without installing the proper conversion kit may result in fire or explosion! NEVER ATTACH THIS APPLIANCE TO A GAS SUPPLY FOR WHICH IT IS NOT CONFIGURED.

Conversion of this appliance from one type of gas to another should only be performed by qualified, licensed, and authorized installation or service personnel, as defined in Section 1.6 of this manual.

FBCR18 & FBKR18 SERIES GAS RETHERMALIZERS

CHAPTER 3: OPERATING INSTRUCTIONS

3.1 Introduction

⚠ WARNING

The on-site supervisor is responsible for ensuring that operators are made aware of the inherent hazards of operating a gas-fired heated water system, particularly the aspects of draining and cleaning procedures.

Mechanically, the FBCR18 and FBKR18 rethermalizers are virtually identical. The FBKR18 units have a manual fill switch in addition to the AutoFill feature.

The primary difference between the two rethermalizers is the controller. Both units use modified Computer Magic III (CM III) computers. Although the computers are very similar in appearance (and to standard CM III computers), they are not interchangeable.

3.2 FBCR18 Series Computer

This computer has 12 programmable product buttons and a “chill” switch. The chill switch shuts off the burners, but does not turn off the computer. This allows unused product to be quickly cooled before being returned to a refrigerator or freezer.

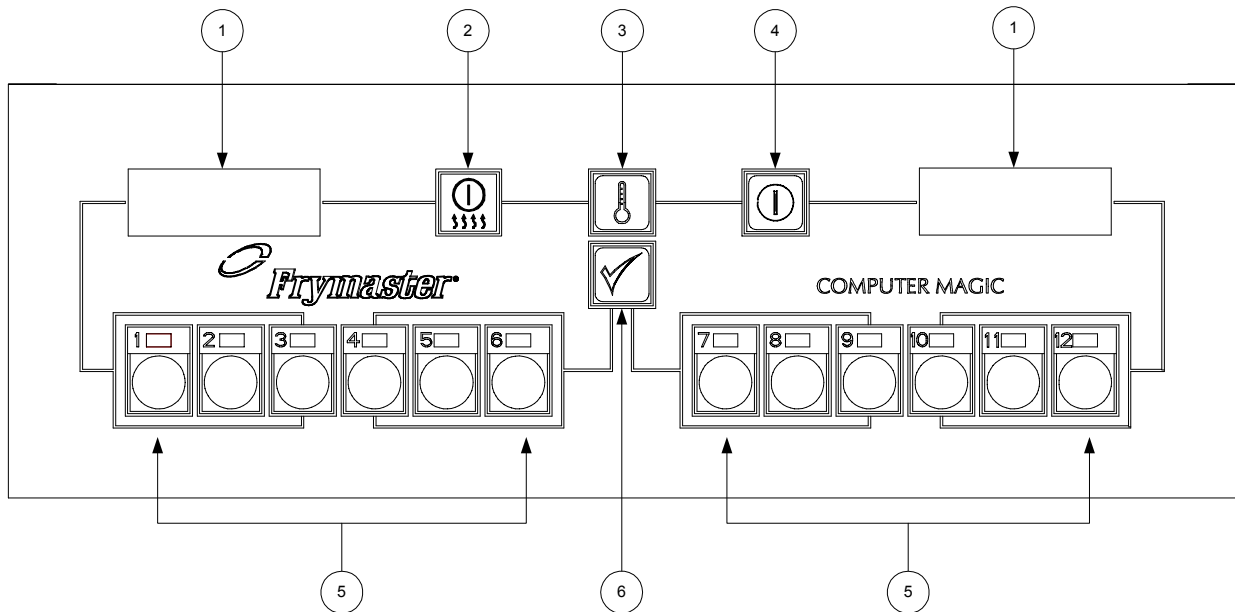

The product buttons are multi-functional. In the programming mode, each button can be programmed for a distinct rethermalizing time. In the rethermalizing mode, pressing a button initiates a specific timed countdown.





FBCR18 Series Computer



| | | | |
|---|--------------------------------|---|---------------------|
| 1 | LED Displays | 4 | Power Switch |
| 2 | Chill Switch | 5 | Product Buttons |
| 3 | Temperature Check/Program Lock | 6 | Program Mode Switch |

PROGRAMMING THE FBCR18 SERIES COMPUTER



1. Turn the computer on by pressing the Power  switch.
2. Press the Program Mode  switch. **Code** appears in the left display. Press, in sequence, product buttons 1, 6, 5, and 10. (Press switch again to exit the programming mode.)

NOTE 1: The programming mode is not available while the computer is rethermalizing; the display will flash **BUSY**.

NOTE 2: To toggle between Fahrenheit and Celsius temperature display, press the Program Mode  switch, then enter the code 1 6 5 8 by pressing the corresponding product buttons. Next, press the Temperature Check/Program Lock  switch to lock in the new display option.

3. **SP-** is displayed in the left window and the setpoint in the right. Use the product buttons to change the temperature up to 205°F (96°C). For example, pressing 1, 9, and 5 programs the setpoint for 195°. When the correct setpoint is displayed, press the Program Mode  switch.
4. **SELP** (Select Product) appears in the display and the LEDs in the product buttons blink. Press any of the product buttons to select it for programming.
5. **PULL** appears in the display. Press the product buttons to enter the desired heating time in minutes and seconds. Press the Program Mode  switch to lock it in.
6. **SELP** again appears in the display. To program the heating time for another product, press the product button to be associated with it and repeat Step 5.
7. Press the Program Lock  switch to exit the programming mode.

OPERATING THE FBCR18 SERIES RETHERMALIZER

1. Press the Power  switch. The AutoFill feature will activate if the water level is below the upper water level sensor.
2. **CYCL** appears in the display and the unit enters a burner on/off cycle until the water in the cookpot reaches 180°F (82°C). At that time, the display changes to **-Lo-** and the burners fire continuously. When the water in the cookpot is within 3°F of setpoint, the display changes to four dashes (- - - -), indicating that the unit is ready for use. **NOTE:** To view the water temperature, press the Temperature Check  button once. Press the button twice to display the setpoint.
3. After the four dashes appear in the display, place the product basket in the cookpot and press the corresponding product button. The display counts down the heating time. The display changes to **PULL**. The small LED in the product button blinks and an alarm sounds to alert you to remove the product. Press the button to silence the alarm.

USING THE FBCR18 CHILL FEATURE

If you rethermalize more food than you use, use the chill feature to quickly reduce the temperature of the food before refrigerating or freezing.

1. Press the Chill Mode  switch to de-energize the heating elements.
2. Open the drain valve and drain most of the hot water. The AutoFill will refill the cookpot with cold water. If desired, add ice to the cookpot to accelerate the cooling process.
3. Remove the product bags when cooled and return them to the refrigerator or freezer.

FBCR18 TEMPERATURE DISPLAY OPTIONS

NOTE: To enter the programming mode, press the Program Mode  switch. When the display reads **CodE**:

- Enter 1, 6, 5, 1 to toggle *constant temperature display* on and off. **NOTE:** When in constant temperature display mode, the countdown time will not be displayed.
- Enter 1, 6, 5, 8 to toggle between *Fahrenheit and Celsius temperature display*.

FBCR18 COMPUTER DISPLAY MESSAGES

- **SELP** – Prompts you to select a product button for programming.
- **CodE** – Prompts you to enter a sequence of numbers to change functions.
- **CYCL** – Indicates the rethermalizer is in the burner on/off cycle mode.
- **-HI-** – Indicates the water temperature is more than 3°F above setpoint.
- **-Lo-** – Indicates that the water temperature is more than 3°F below setpoint.
- **- - - -** (four dashes) – Indicates the water temperature is within the proper rethermalizing range (i.e., within ±3°F of setpoint).
- **HELP** – Indicates a heating problem. Call your local Frymaster Factory Authorized Service Center or the 24-Hour Hotline (1-800-551-8633).
- **Prob** - Indicates a problem in the temperature control circuits. Call your local Frymaster Factory Authorized Service Center or the 24-Hour Hotline (1-800-551-8633).

3.3 FBKR18 Series Computer

This computer has 10 programmable product buttons, a Simmer Mode switch, and a Boil Mode switch. The computer also has two Power switches; press either switch to turn the unit on and off.

The product buttons are multi-functional. In the programming mode, each button can be programmed for a distinct rethermalizing time. In the rethermalizing mode, pressing a button initiates a timed countdown of a specific product.

Pressing the Boil Mode (**L**) switch overrides the programmed setpoint and the cookpot temperature rises to boiling at 212°F (100°C). When the unit is in boil mode, **boil** appears in both LED displays. The unit remains in boil mode until the Simmer Mode switch is pressed or the unit is turned off.

Pressing the Simmer Mode (**R**) switch causes the cookpot temperature to be maintained at the programmed setpoint. If the cookpot temperature is above the setpoint, °**HI** is displayed in both LED widows. If the cookpot temperature is below the setpoint, °**Lo** is displayed. Four dashes (- - -) are displayed if the temperature is within 11°F (6°C) of setpoint.

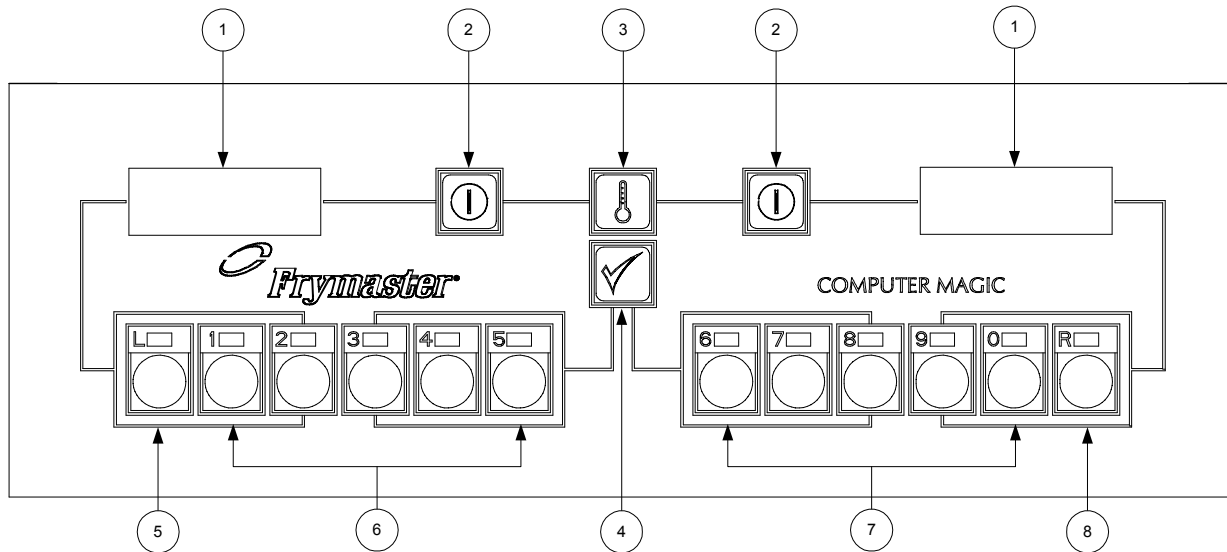

FBKR18 Series Computer



| | | | |
|---|--------------------------------|---|------------------------------|
| 1 | LED Displays | 5 | Boil Mode Switch |
| 2 | Power Switches | 6 | Product Buttons 1 through 5 |
| 3 | Temperature Check/Program Lock | 7 | Product Buttons 6 through 10 |
| 4 | Program Mode Switch | 8 | Simmer Mode Switch |

PROGRAMMING THE FBKR18 SERIES COMPUTER

⚠ CAUTION

It is recommended that the simmer setpoint and the heat/stir times for all 10 products be programmed before the unit is first used in a rethermalizing cycle.

The simmer setpoint and product rethermalizing times are programmed at the factory. These are **test** settings **not** default settings. You must program the unit for your own particular products. Program the setpoint and all product rethermalizing times as follows:

1. Turn the computer on by pressing the Power  switch.
2. Enter the programming mode by pressing the Program Mode  switch. **Code** appears in the left display. Press the switch again to exit the programming mode.

NOTE 1: Programming mode is not available while the computer is rethermalizing; the display will flash **BUSY**.

NOTE 2: To toggle between Fahrenheit and Celsius temperature display, press the Program Mode switch, then enter the code 1 6 5 8 by pressing the corresponding product buttons. Next, press the Temperature Check/Program Lock switch to lock in the new display option.

3. Enter the number 1 6 5 0 by pressing the corresponding product buttons. Unless this code is entered, programming will not be accepted. This is to prevent unauthorized changes to your current instructions.
4. **SP-r** (Setpoint) appears in the left LED display. Any previously programmed temperature setpoint appears in the right display. To change the setpoint, enter the desired setpoint temperature using the corresponding product buttons. The setpoint can be programmed for any value up to 212°F (100°C). Press the Program Mode switch to lock in the new setpoint (or the old setpoint, if it was not changed).
5. **SELP** (Select Product) appears in the left display. Press the product button to be programmed (or press to return to the normal operating mode).
6. **COOC** (Rethermalizing Time) appears in the left display. Any previously programmed rethermalizing time will appear in the right display. Press to accept the current rethermalizing time or enter a new time using the product buttons. The rethermalizing time can be programmed up to 59:59. Press to lock in the new time.

NOTE: The computer can be programmed for either “standard” or “slow” clock. The standard clock displays minutes and seconds, the slow clock displays hours and minutes. To toggle back and forth between times press the Program Mode switch, then enter the code 1 6 5 3 using the product buttons. Press the Temperature Check/Program Lock switch to lock in the clock speed. To determine whether the clock speed is set to standard or slow, initiate a rethermalizing cycle by pressing a product button. If the computer is set to the standard clock, the time in the LED display will immediately begin to count down. If it does not, the computer is set to the slow clock.

7. **SH1** (Stir Time 1) appears in the left display. Enter the number of seconds to heat before the stir alarm sounds using the product buttons; for no stir alarm, enter “0”. The number entered will appear in the right display. For example, entering “30” means the product needs to be stirred after it has been rethermalizing for thirty seconds.

The stir time can be programmed up to 59:59, **but must not exceed the product rethermalizing time**. Press to lock in the programmed time.

SH2 appears. Program the time of the second stir alarm as above, being sure that the time entered is greater than that for stir alarm 1 or else is “0”.

SH3 appears. Program the time of the third stir alarm in the same manner as for Stir Times 1 and 2, being sure that the time entered is greater than that for stir alarm 2 or else is “0”.



Remember: Stir time 2 must be greater than stir time 1 (or else be “0”). Stir time 3 must be greater than stir time 2 (or else be “0”). None of the stir times should be greater than the rethermalizing time entered in Step 6. If a stir time exceeds the rethermalizing time, the stir alarm will not sound.

8. **SELP** (Select Product) again appears in the left display. Return to Step 5 and follow all instructions to program more products.
9. Lock in the programming by pressing the Temperature Check/Program Lock Switch .

OPERATING THE FBKR18 SERIES RETHERMALIZER

Turn the computer on by pressing the Power  switch. **NOTE:** A decimal between digits 1 and 2 in either LED Display indicates that the element is energized.

1. One of the following is displayed:
 - a. **°-Lo**, indicates the cookpot temperature is 11°F (6°C) lower than the setpoint.
 - b. **°-HI**, indicates the cookpot temperature is 11°F (6°C) higher than the setpoint.
 - c. - - - - (four dashes), indicates the cookpot temperature is in the rethermalizing range.
 - d. **HELP**, indicates a heating problem.
 - e. **Prob**, indicates a problem with the computer temperature probe circuit.
2. Press a product button to initiate a rethermalizing cycle.
 - a. The programmed rethermalizing time appears and the timer countdown will begin.
 - b. Stir alarms, if programmed, will sound, the display will read **Stir**, and the LED in the product button will blink. Press the indicated product button to cancel the alarms.

CAUTION

Pressing the product button twice while the alarm is active will cancel the rethermalizing cycle as well as the alarm.

- c. An alarm sounds at the end of the cycle. **COOC** is displayed, and the associated product button flashes. To cancel the alarm, press the flashing button.
3. Press the Temperature Check  switch once to check the cookpot temperature. Press the switch twice to check the setpoint.
4. During idle periods, four dashes (- - - -) should appear in both displays, indicating that the cookpot is at setpoint.

FBKR18 TEMPERATURE DISPLAY OPTIONS

To change the temperature display, press the Program Mode switch; **Code** appears in the display.

- To toggle *constant temperature display* on and off, enter 1, 6, 5, 1, . **NOTE:** When in constant temperature display mode, the countdown time will not be displayed.
- To toggle between *Fahrenheit and Celsius temperature display*, enter 1, 6, 5, 8, .

FBKR18 COMPUTER DISPLAY MESSAGES

- **SELP** – Prompts you to select a product button for programming.
- **Code** – Prompts you to enter a sequence of numbers to change functions.
- **°-HI** – Indicates that the water temperature is more than 3°F above setpoint.
- **°-Lo** – Indicates that the water temperature is more than 3°F below setpoint.
- - - - - (four dashes) – Indicates that the water temperature is within the proper rethermalizing range (i.e., within ±3°F of setpoint).
- **HELP** – Indicates a heating problem. Call your local Frymaster Factory Authorized Service Center or the 24-Hour Hotline (1-800-551-8633).
- **Prob** – Indicates a problem in the temperature control circuits. Call your local Factory Authorized Service Center or the 24-Hour Hotline (1-800-551-8633).

FBKR18 BOIL OR SIMMER MODE OPTIONS

Pressing the Boil Mode (**L**) switch overrides the programmed setpoint and the cookpot temperature rises to boiling at 212°F (100°C). When the unit is in boil mode, **boil** appears in both LED displays. The unit remains in boil mode until the Simmer Mode switch is pressed or the unit is turned off.

Pressing the Simmer Mode (**R**) switch causes the cookpot temperature to be maintained at the programmed setpoint. If the cookpot temperature is above the setpoint, **°-HI** is displayed in both LED widows. If the cookpot temperature is below the setpoint, **°-Lo** is displayed. Four dashes (- - - -) are displayed if the temperature is within 11°F (6°C) of setpoint.

FBKR18 CLOCK SPEED OPTIONS

The computer can be programmed for either “standard” or “slow” rethermalizing times. The standard clock displays minutes and seconds, the slow clock displays hours and minutes. To toggle back and forth between times press the Program Mode switch, then enter 1, 6, 5, 3, . To determine whether the clock speed is set to standard or slow, initiate a rethermalizing cycle by pressing a product button. If the computer is set to the standard clock, the time in the LED display will immediately begin to count down. If it does not, the computer is set to the slow clock.

3.4 Start-Up Procedure (Applies to both the FBCR18 and FBKR18)

⚠ WARNING

Never operate this appliance with an empty cookpot. The cookpot must be filled with water before lighting the burners.

⚠ CAUTION

If this is the first time the unit is being used after installation, refer to Section 3.5, Boiling-Out the Cookpot.

Before turning the rethermalizer on, ensure that:

- the unit is connected to the water supply
- that the water supply is turned on
- that the unit is plugged into a 120VAC outlet
- that the electrical power supply to the rethermalizer is turned on
- that the gas supply to the rethermalizer is turned on.

1. Turn the gas valve to the ON position (see illustration below).

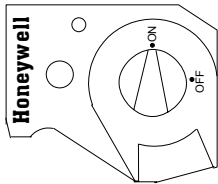

2. Press the computer Power  switch. (On FBKR18 units, press either power switch.)

The AutoFill will, if necessary, add water until it reaches the upper water level sensor. The AutoFill solenoid valve will cut off the water flow.

On FBKR18 Series units, a manual fill momentary switch (located on the component box cover inside the door) may be pressed to override the solenoid valve and add water to the unit. Water is added as long as the switch is pressed.

When the water level is above the lower water level sensor, the burners light for several seconds then go out. A few seconds later they will light again. This cycle repeats until the water reaches 180°F (82°C). The burners then remain lit until the setpoint is reached. During the cycling, FBCR18 Series units display **CYCL**. At 180°F (82°C), the display changes to **°-Lo**. FBKR18 Series units will display **°-Lo**. For either series, when the unit reaches setpoint, the display changes to four dashes (- - - -), indicating the unit is ready for use.

Observe the burners through the burner viewing ports after 90 seconds of ignition. Look for a bright orange-red glow. A blue flame or dark spots on a burner face indicate the air/gas mixture requires adjustment. Refer to Chapter 4, Section 4.4, *Clean Combustion Air Blower* for adjustment procedures.

3.5 Boiling-Out the Cookpot

DANGER

Never leave the appliance unattended during the boil-out process. If the boil-out solution boils over, turn the appliance off immediately and let the solution cool for a few minutes before resuming the process. To lessen the chance of boil over, turn the appliance's gas valve knob to the PILOT position occasionally.

To ensure that the cookpot is free of any contamination resulting from its manufacture, shipping, and handling during installation, the cookpot must be boiled out before first use.

1. Close the drain valve and fill the cookpot with a solution of cold water and 1 cup of boil-out solution or detergent.
2. Place the unit into operation in accordance with Section 3.4.
3. **On FBCR18 Series units**, program the setpoint for 195°F (91°C). Program one of the product buttons for 59 minutes and 59 seconds. Initiate the heating cycle by pressing the button.

On FBKR18 Series units, press the Boil (L) switch and allow the boil-out solution to boil for one hour.

4. After the solution heats for an hour, turn the unit off, allow the solution to cool, then add 2 gallons (7.75 liters) of cold water and stir. Drain the solution and clean the cookpot thoroughly.
5. Rinse the cookpot at least twice by filling with clean water and draining.
6. On FBCR18 Series units, reprogram the setpoint to the appropriate temperature, and reprogram the product button for the appropriate time.

3.6 Shutting the Rethermalizer Down

1. Turn the unit off by pressing the Power  switch (on FBKR18 units, press either switch).
2. Drain and clean the cookpot, put the cookpot cover in place, and turn the gas valve to the OFF position. (See illustration below.)

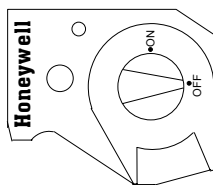

CAUTION

The electronic circuitry in your computer can be affected adversely by current fluctuations and electrical storms. Should it fail to function or program properly for no apparent reason, the computer should be reset by unplugging the computer and plugging it back in. This could prevent a service call.

FBCR18 & FBKR18 SERIES GAS RETHERMALIZERS

CHAPTER 4: PREVENTIVE MAINTENANCE

4.1 Daily Checks and Services

Inspect Rethermalizer and Accessories for Damage

Look for loose or frayed wires and cords, leaks, foreign material in cookpot or inside cabinet, and any other indications that the rethermalizer and accessories are not ready and safe for operation.

Clean Cabinet Inside and Out

Clean inside the cabinet with a dry, clean cloth. Wipe all accessible metal surfaces and components to remove accumulations of oil, dust, or cooking residue.

Clean the outside of the cabinet with a clean cloth dampened with dishwashing detergent, removing oil, dust, or cooking residue.

 **DANGER**

Never attempt to clean this appliance when it is in use or filled with water heated to cooking/rethermalizing temperature.

 **WARNING**

Use a commercial-grade cleaner formulated to effectively clean and sanitize food-contact surfaces. Read the directions for use and precautionary statements before use. Particular attention must be paid to the concentration of cleaner and the length of time the cleaner remains on the food-contact surfaces.

Clean Water-Level Sensors, Temperature Probe, and Cookpot

Press the computer power switch to the OFF position.

Remove the cap nut at the top of the shield (located on the left front of the cookpot) and remove the shield by lifting up until it can be removed from the stud that holds it at the bottom. Clean the exposed screw heads with a solution of detergent and water. A Scotchbrite™ or equivalent nylon pad may be used to scrub away any accumulated mineral deposits.



Clean the temperature probe, located on the lower front centerline of the cookpot, using a small bottlebrush wet with a solution of detergent and water.

Using a Scotchbrite™ or similar abrasive pad and a solution of detergent and water, clean the inside of the cookpot.

Rinse the cookpot thoroughly with clean water at least twice.

4.2 Quarterly Checks and Services

Check Computer Magic III Set Point Accuracy

1. Fill the cookpot with water. Press the computer power switch, and then press any of the product buttons. Insert a good-grade thermometer or pyrometer probe into the cookpot, with the end touching the temperature probe at the lower right front of the cookpot.
2. When the computer display shows a series of four dashes (- - - -), press the  switch once to display the temperature of the water as sensed by the temperature probe. Press the  switch twice to display the set point. The displayed water temperature should be within $\pm 10^{\circ}\text{F}$ (5°C) of the setpoint and the temperature shown on the thermometer or pyrometer should be within $\pm 5^{\circ}\text{F}$ (2°C) of the displayed water temperature. If either set of readings is outside its range, contact a Factory Authorized Service Center for assistance.

4.3 Semi-Annual Checks and Services

Clean Combustion Air Blower

1. Unplug the rethermalizer.
2. There are 4 wires (2 orange, 1 white, and 1 black) running from the motor. Remove the wire nuts and disconnect these wires from the rethermalizer wiring harness, marking each to ensure proper reconnection.
3. Remove the 4 nuts and bolts securing the blower to its mounting bracket and remove the blower from beneath the rethermalizer.
4. Remove the 3 motor flange nuts from the side of the blower housing and remove the motor and blower wheel from the housing.
5. Wrap the motor with plastic wrap to prevent water from entering it. Spray degreasing detergent on the blower wheel and blower housing. Wait 5 minutes, then rinse under hot water, being careful not to get water into the motor. Dry with a clean cloth.
6. Reverse steps 1-5 to reinstall the blower.
7. Light the rethermalizer in accordance with the procedure described in Chapter 3, Section 3.1.
8. After the burners have been lit for at least 90 seconds, observe the flames through the burner viewing ports. The air/gas mixture is properly adjusted when the burner manifold gas pressure is in accordance with the table on page 4-3 and the burners display a bright orange-red glow. If a blue flame is observed, or if there are dark spots on a burner face, the air/gas mix requires adjustment.

On the side of the blower housing opposite the motor is a plate with one or two locking nuts. Loosen the nut(s) enough to allow the plate to be moved, then adjust the position of the plate to

open or close the air intake opening until a bright orange-red glow is obtained. Carefully hold the plate in position and retighten the nut(s).

Clean Gas Valve Vent Tube

1. Set the rethermalizer power switch and the gas valve to the OFF position.
2. Carefully unscrew the vent tube from the gas valve. NOTE: The vent tube may be straightened for ease in removal.

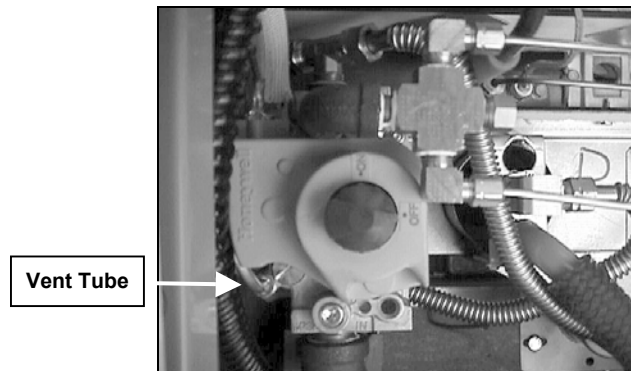

3. Pass a piece of ordinary binding wire (.052 inch diameter) through the tube to remove any obstruction.
4. Remove the wire, then blow through the tube to ensure it is clear.
5. Reinstall tube and bend so that the opening is pointing downward.

Check Burner Manifold Pressure

⚠ DANGER
This task should be performed by qualified service personnel only. The cookpot must be filled with water during this procedure.

1. Ensure that the gas valve knob is in the OFF position.
2. Remove the pressure tap plug from the gas valve assembly and attach the fitting for a gas pressure-measuring device to the tap.

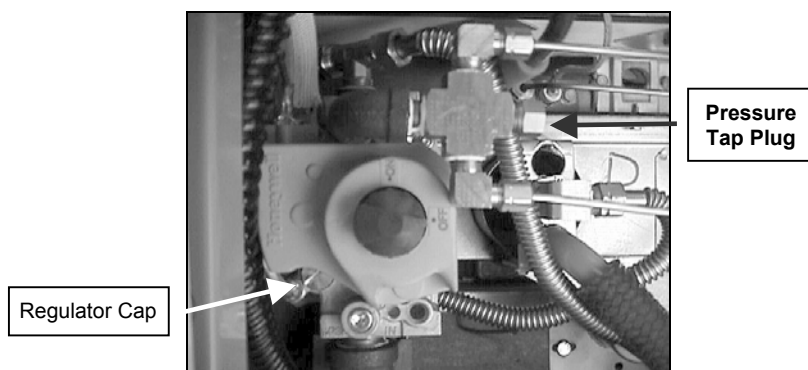

- Place the gas valve in the ON position. Place the computer power switch in the ON position. When the burner lights and continues to burn, compare the indicated pressure to the table below.

| Burner Manifold Gas Pressures | |
|--------------------------------------|-----------------------|
| Gas | Pressure |
| Natural | 3.5" W.C. 0.8 kPa |
| LP | 8.25" W.C. 2.5 kPa |

- If necessary, adjust the burner gas pressure by removing the cap from the gas valve regulator and turning the regulator screw to obtain the correct pressure. When the correct pressure is obtained, reinstall the cap.
- Place the rethermalizer power switch and the gas valve in the OFF position. Remove the fitting from the pressure tap hole and reinstall the pressure tap plug.

FBCR18 & FBKR18 SERIES GAS RETHERMALIZERS

CHAPTER 5: OPERATOR TROUBLESHOOTING

5.1 Introduction

 **DANGER**

Water heated to cooking/rethermalizing temperature will cause severe burns. Never attempt to move this appliance when filled with heated water or to transfer heated water from one container to another.

 **DANGER**

This equipment should be unplugged when servicing, except when electrical circuit tests are required. Use extreme care when performing such tests.

This appliance may have more than one electrical power supply connection point. Disconnect all power cords before servicing.

Inspection, testing, and repair of electrical components should be performed by an authorized service agent only.

This chapter provides an easy reference guide to the more common problems that may occur during the operation of your equipment. The troubleshooting guides in this chapter are intended to help you correct, or at least accurately diagnose, problems with your equipment. Although the chapter covers the most common problems reported, you may very well encounter a problem not covered. In such instances, the Frymaster Technical Service Department will make every effort to help you identify and resolve the problem.

When troubleshooting a problem, always use a process of elimination starting with the simplest solution and working through to the most complex. Never overlook the obvious. Anyone can forget to plug a cord into a receptacle or open the valve on the water supply line. Don't assume that you are exempt from such occurrences.

Always try to establish a clear idea of why a problem has occurred. Part of your corrective action involves taking steps to ensure that it doesn't happen again. If a controller malfunctions because of a poor connection, check all other connections while you're at it. If a fuse continues to blow, find out why. Keep in mind that failure of a small component may often be indicative of potential failure or incorrect functioning of a more important component or system.

Each guide begins with a description of a common problem in a six-sided figure. Simply follow the arrows and answer the questions to determine the corrective action to take. If you have doubts as to the proper action to take, do not hesitate to call the Frymaster Technical Service Department or your local Frymaster Factory Authorized Service Center for assistance.

5.2 Troubleshooting Guides

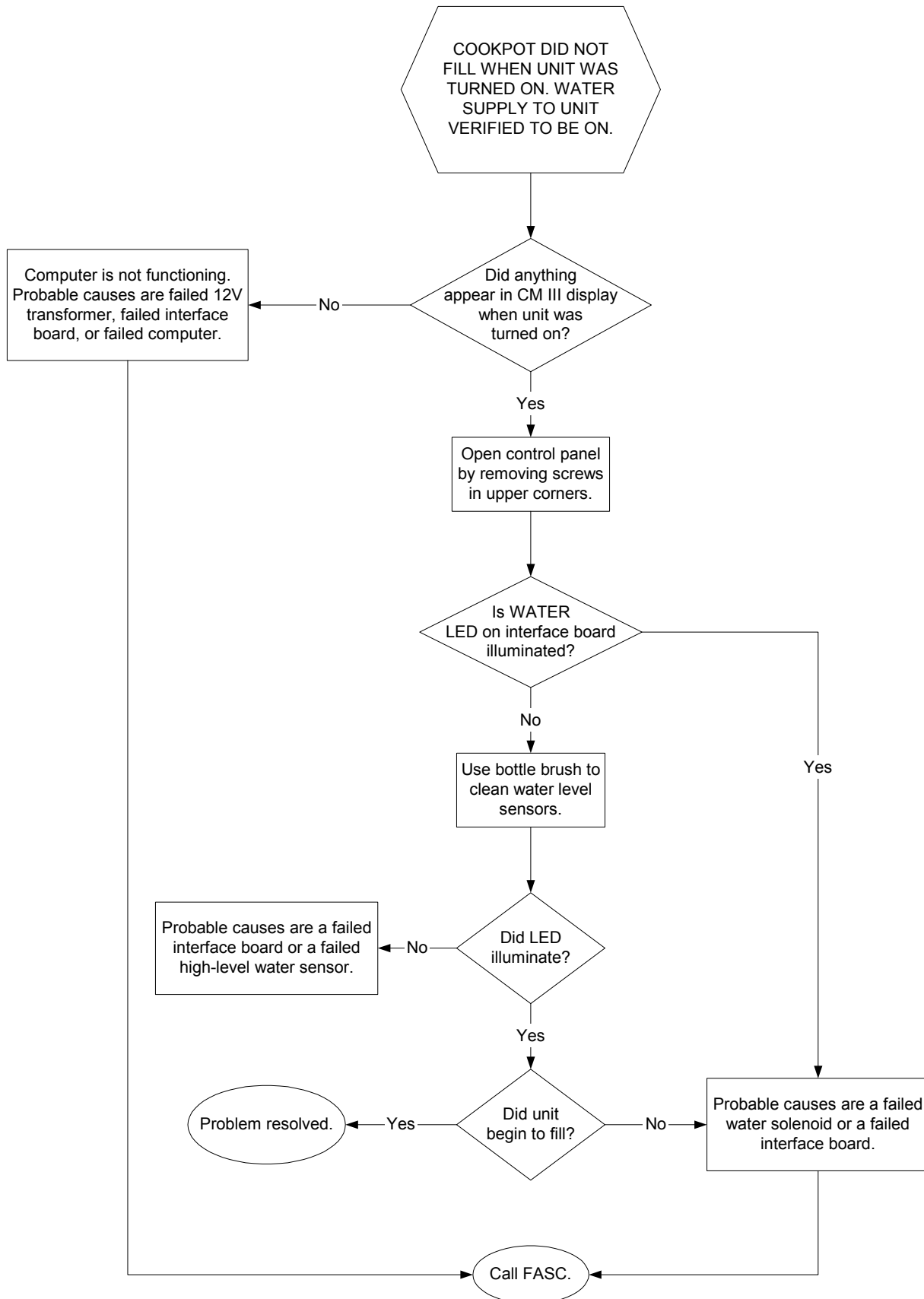

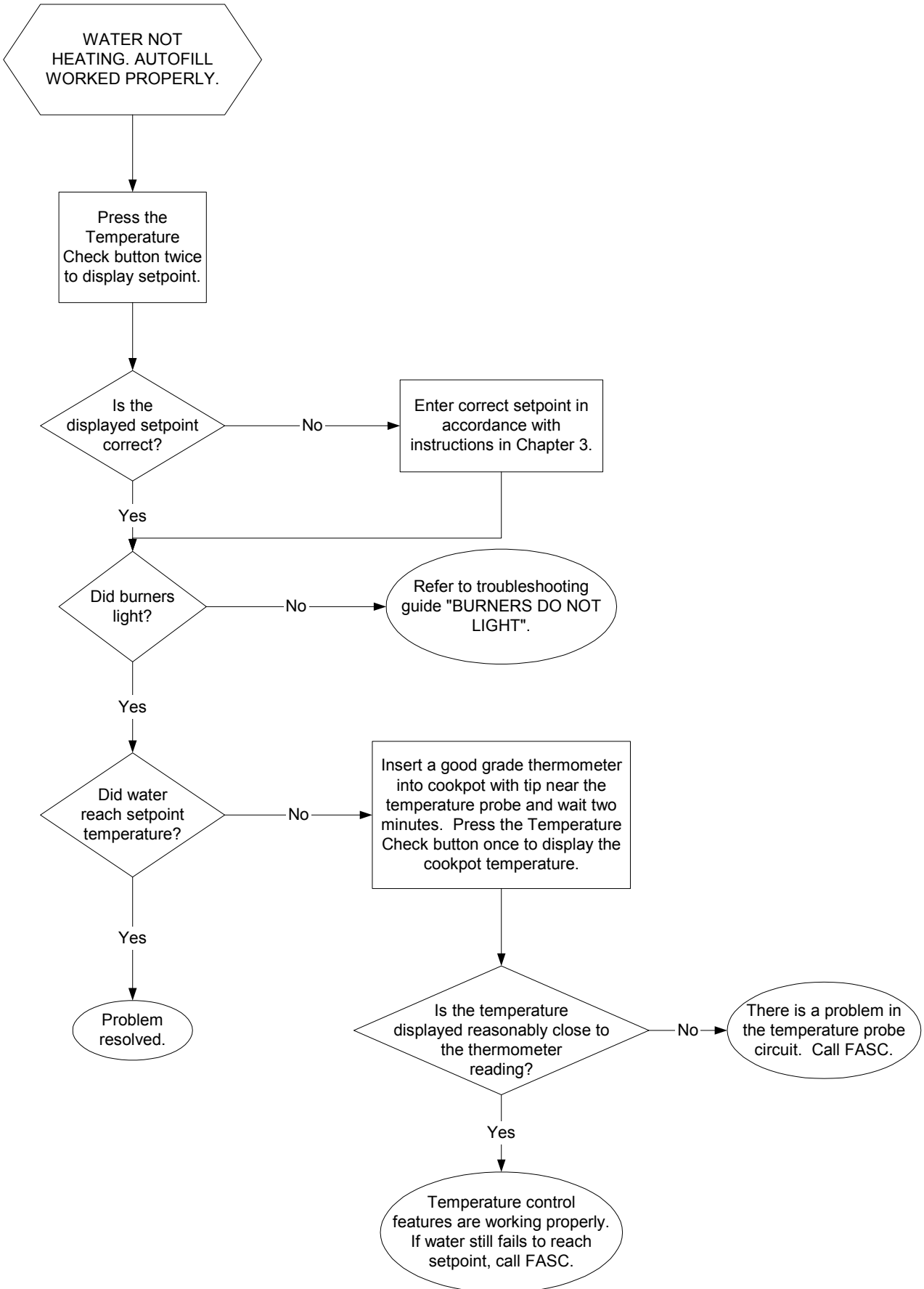

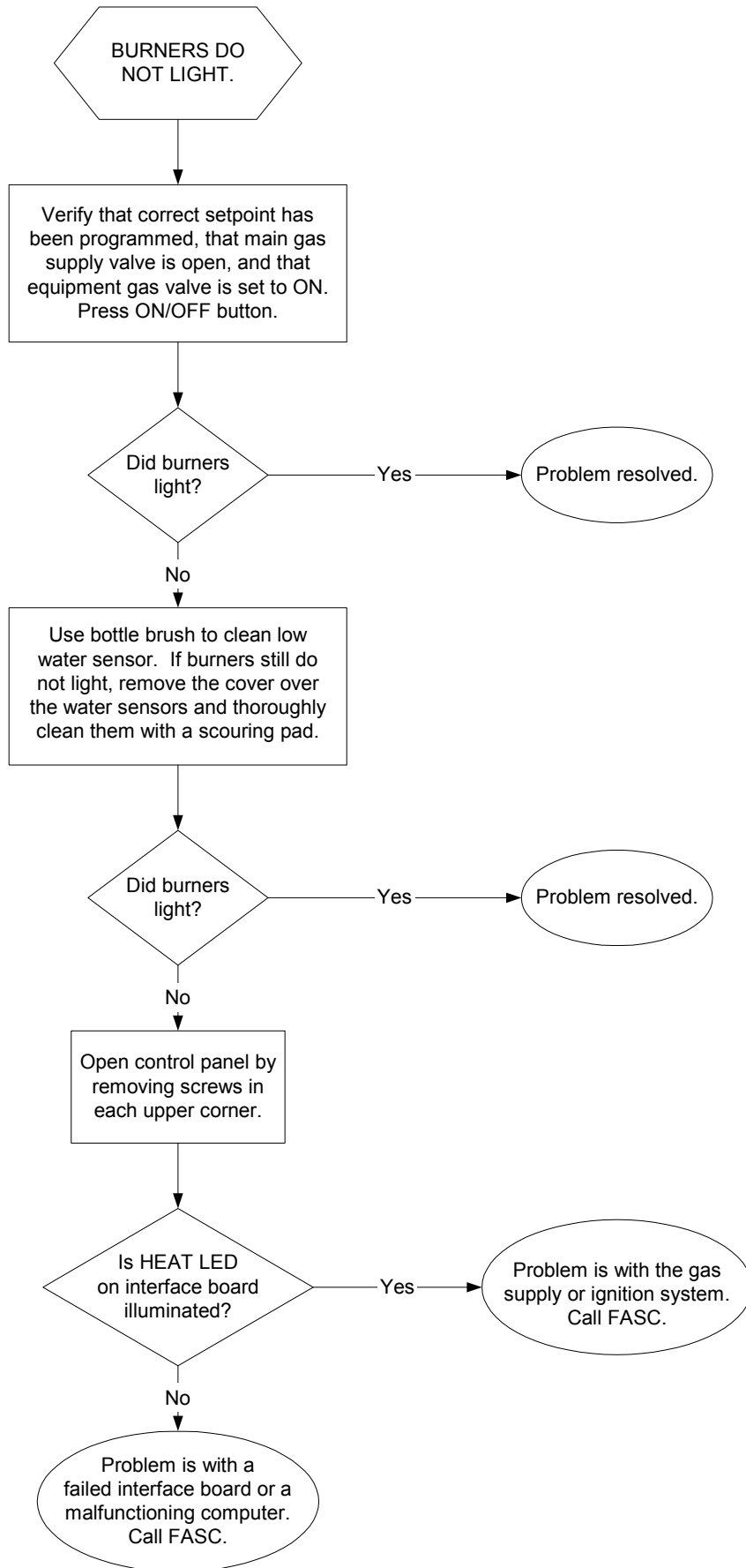

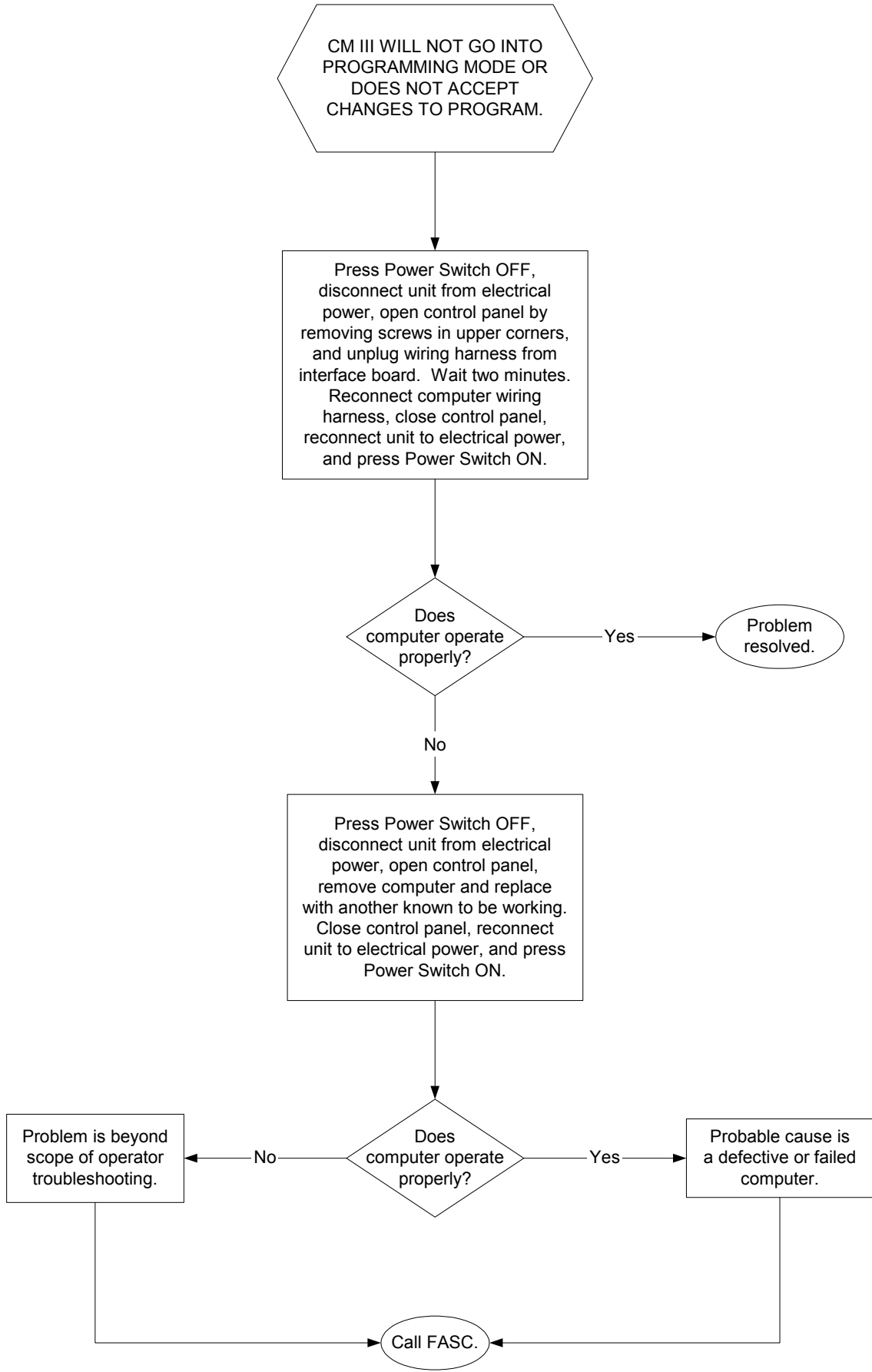

5.3 Replacing the Computer or Computer Wiring Harness

1. Disconnect the rethermalizer from the electrical supply.
2. Remove the two screws in the upper corners of the control panel and swing the panel open from the top, allowing it to rest on its hinge tabs.
3. Disconnect the wiring harness from the back of the computer. If replacing the harness, disconnect it from the interface board, install the new harness, and then reverse steps 1 and 2 to complete the process.
4. Disconnect the ground wire from the computer. Remove the control panel by lifting it from the hinge slots in the frame.

If substituting one complete control panel for another, reverse steps 1-4 to complete the procedure.

If replacing the computer, remove the nuts securing the computer to the control panel and install the replacement computer on the control panel. Reverse steps 1-4 to complete the procedure.

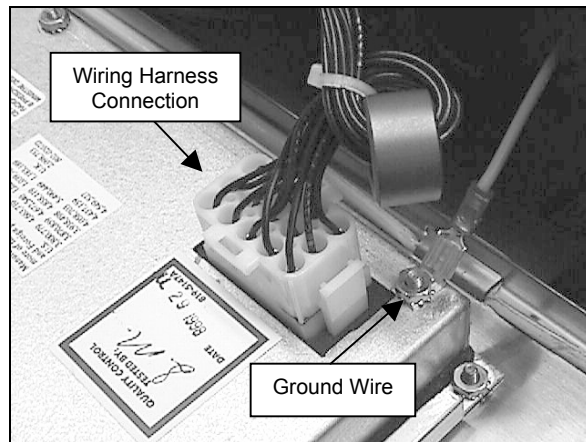

FBCR18 & FBKR18 SERIES GAS RETHERMALIZERS

CHAPTER 6: SERVICE PROCEDURES

6.1 Functional Description

These rethermalizers contain a welded stainless steel cookpot that is directly heated by a high efficiency burner system requiring approximately 43% less energy than conventional burner systems to heat the same volume of water.

Two self-contained combustion chambers (referred to as “burners”) are located beneath the cookpot. Each combustion chamber is fitted with special ceramic tiles that are heated by the burning of a forced air/gas mixture. The tiles transfer their heat to the cookpot by means of infrared radiation, providing much more constant and uniform heat dispersion over the surface of the cookpot than do conventional burners. Because relatively less heat is lost to the atmosphere in the process, compared to “open-burner” designs, less fuel is required to achieve and maintain a given cookpot temperature.

Gas flow to both of the burners is regulated by one electromechanical gas valve.

THE ELECTRONIC IGNITION SYSTEM

Ignition modules, located in the component box, are connected to ignitor assemblies at each burner. An ignition module performs four important functions: it provides fuse protection for the 24-volt circuit, provides an ignition spark, supplies voltage to the gas valve, and proofs the burner flame.

The module contains a 4-second time delay circuit and a coil that activates the gas valve. The ignitor assembly consists of a spark plug, an enrichment tube, and a flame sensor.

At start-up, the power switch is placed in the ON position, supplying approximately 12-volts DC to the heat control circuitry in the controller or computer and to one side of the heat relay coil on the interface board. If resistance in the temperature probe indicates the temperature in the cookpot is below 180°F (82°C), the current flows through a circuit containing a timer switch that alternately closes for 6 seconds and opens for 24 seconds. If the temperature is 180°F (82°C) or above, the current flows through a heat circuit, bypassing the timer switch. In either case, ground is supplied to the other leg of the heat relay coil, which then closes an electronic switch in the 24 VAC circuit to provide current to the ignition module.

Circuitry in the ignition module sends 24 VAC to the gas valve. Simultaneously, the module causes the ignitor to spark for 4 seconds to light the burner. A flame sensor verifies that the burner is lit by measuring the flow of microamps through the flame. If the burner does not light (or is extinguished), current to the ignition module is cut, preventing the main valve from opening, and the ignition module “locks out” until the power switch is turned off and then back on.

A probe monitors the temperature in the cookpot. When the programmed setpoint temperature is reached, resistance in the probe causes the heat cycle circuitry in the controller to cut off current flow through the heat relay. This in turn cuts off the 24 VAC to the ignition module, causing the gas valve to close.

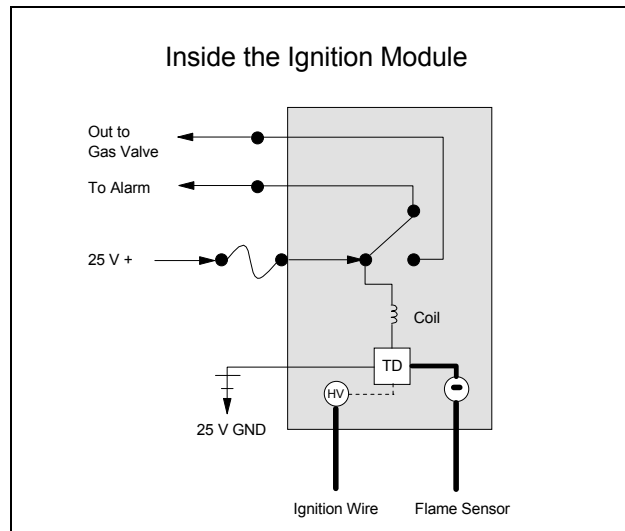

COMPUTERS

These rethermalizers are equipped with Computer Magic III computers that have been modified for this specialized application. Although similar in appearance to standard Computer Magic III computers, the standard CM III computers will not operate the unit correctly. *Only part number 806-8063 may be used in FBCR18 units and only part number 806-9352 may be used in FBKR18 units.*

INTERFACE BOARD

An interface board is located in the component box directly behind the control panel. The interface board provides a link between the computer and the rethermalizer's individual components without requiring excessive wiring, and allows the computer to execute commands from one central point. The part number for the interface board used in this equipment is 806-9295. A simplified illustration of the board is provided below.

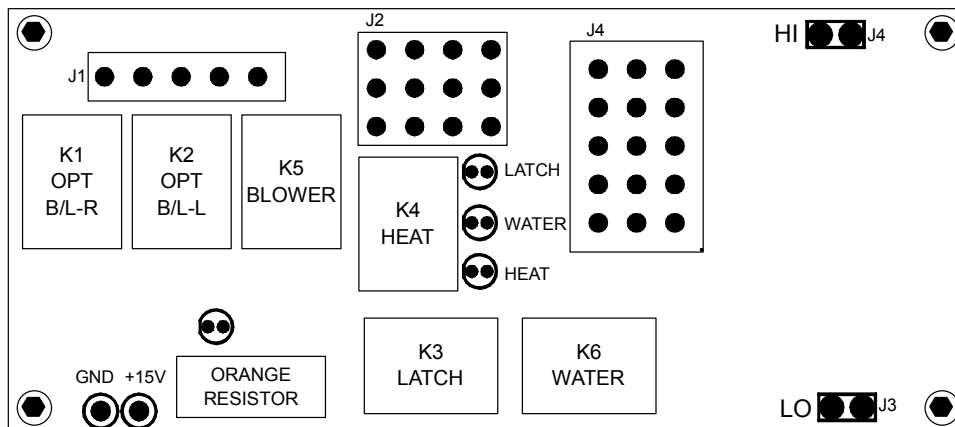

The board contains a heat relay (K4) that switches 24VAC to the ignition and gas valve circuits when the computer heat logic circuit calls for heat. Relay K5 switches 120VAC to the blower motor when K4 closes. The water relay (K6) has two functions. First, it breaks the 24VAC circuit when the water level in the cookpot is below the lower water level sensor. This prevents the burners from firing when the unit is empty. The second function is to supply power to the normally open water

solenoid valve when the water level reaches the upper water level sensor and to de-energize the solenoid when the water level drops below the upper water level sensor.

The board has four LEDs to assist in troubleshooting. Three of the LEDs (LATCH, WATER, and HEAT) are located just to the right of the heat relay (K4). The fourth LED is not labeled. It is located in the lower left portion of the board, just above a large orange resistor. When the latch, water, and heat LEDs are illuminated, they indicate that the associated relay is closed. The unlabeled LED indicates that 24VAC is being supplied to the interface board by the transformer.

TEMPERATURE PROBE

A temperature probe is located on the front centerline of the cookpot. The probe is a type of thermostat in which the resistance varies directly with the temperature. That is, as the temperature rises, so does resistance, at a rate of approximately 2 ohms for every 1° of rise or fall. Circuitry in the computer monitors the probe resistance and controls burner firing when the resistance exceeds or falls below a programmed temperature (setpoint). The temperature is programmed by means of number buttons on the face of the computer.

WATER LEVEL SENSORS

Two water level sensors are arranged one above the other on the left front of the cookpot. When water contacts the sensors they are grounded. The lower sensor acts as a safety device to keep the burner from firing when there is no water in the cookpot. When the sensor is grounded by contact with water, a transistor on the interface board is biased and the blower relay (K5) pulls in, supplying power to the blower and to the gas valve via the ignition modules. Grounding the upper water level sensor causes another transistor on the interface board to bias and pull in the water relay (K6) which closes the water solenoid valve, cutting off water flow into the cookpot.

6.2 Accessing the Rethernalizer for Servicing

DANGER

Water heated to cooking/rethermalizing temperature will cause severe burns. Never attempt to move this appliance when filled with heated water or to transfer heated water from one container to another.

DANGER

This equipment should be unplugged when servicing, except when electrical circuit tests are required. Use extreme care when performing such tests.

This appliance may have more than one electrical power supply connection point. Disconnect all power cords before servicing.

Inspection, testing, and repair of electrical components should be performed by an authorized service agent only.

1. Shut off the gas supply to the unit. Unplug the electrical power cord. Disconnect the unit from the gas supply.
2. Remove any attached restraining devices.

3. Relocate the rethermalizer for service accessibility.
4. After servicing is complete, reconnect the unit to the gas supply, reattach restraining devices, and plug in the electrical power cord.

6.3 Cleaning the Gas Valve Vent Tube

Refer to Semi-Annual Checks and Services in Chapter 4, Preventive Maintenance.

6.4 Checking the Burner Manifold Gas Pressure

Refer to Semi-Annual Checks and Services in Chapter 4, Preventive Maintenance.

6.5 Measuring Flame Current

When the burner flame is properly adjusted, it will produce a current between 3.5 μA and 6.5 μA . Flame current is measured by placing a *microamp* (not milliamp) meter in series with the white sensing wire on the ignitor. This is accomplished as follows:

1. Turn the unit OFF (press the  button).
2. Disconnect the white flame sensor wire from one of the burner ignitor assemblies and connect it to the positive lead of the meter. Connect the negative lead of the meter to the terminal from which the sensing wire was removed.

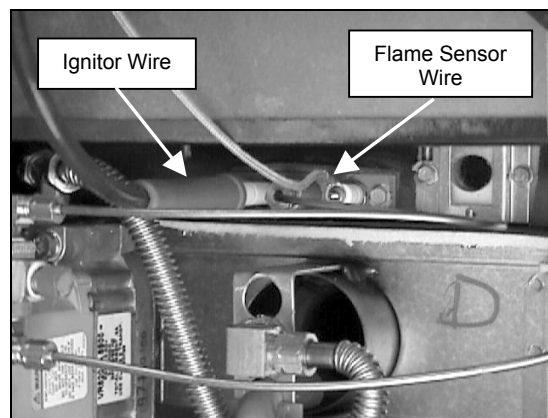

3. Turn the unit ON (press the  button). When a cold unit is first turned on, the burner will cycle on and off repeatedly until the temperature in the cookpot reaches 180°F (82°C). When the water in the unit exceeds that temperature, the burner will stay on until the setpoint is reached. Check the reading when the burner has been on continuously for at least one minute.

6.6 Replacing Components

6.6.1 Replacing the Computer or Computer Wiring Harness

Refer to Chapter 5, Section 5.3 for this procedure.

6.6.2 Replacing the Temperature Probe

1. Unplug the rethermalizer.
2. Drain the cookpot.
3. Remove the screws from the upper corners of the control panel and swing the panel open from the top, allowing it to rest on its hinge tabs.
4. Remove the cover from the component box by removing the three screws along its bottom edge.
5. Cut the temperature probe wires an inch or so from the 12-pin connector. Leave the cut off wires in the connector.
6. Remove the temperature probe and install replacement, resealing with Loctite[®] PST56765 pipe thread sealant or equivalent. Be careful not to damage the leads when installing the new probe.
7. Thread the leads through opening in the bottom of the component box and through the insulating sleeve.
8. Unplug the 12-pin connector from the interface board. Using a pin pusher, remove the cut off pieces of wire from the connector one at a time, and insert the corresponding wire from the new part.
9. Reattach the 12-pin connector to the interface board, replace the component box cover, and close and secure the control panel.

6.6.3 Replacing the Interface Board

1. Unplug the rethermalizer.
2. Remove the screws from the upper corners of the control panel and swing the panel open from the top, allowing it to rest on its hinge tabs.
3. Detach the grounding wire from the computer, unplug the 15-pin connector from the interface board, and remove the control panel from the unit by lifting it up and out of the hinge slots in the control panel frame.
4. Disconnect the 12-pin connector from the interface board.
5. Mark the yellow water level sensor wires and disconnect them from terminals J3 and J5.
6. Remove the nuts in each corner of the interface board and carefully pull the board off the mounting studs, being careful not to dislodge the spacers on the studs.
7. Position the replacement board on the studs and replace the four nuts.
8. Reconnect the water level sensor wires and the 12-pin connector to the interface board.
9. Remount the control panel to the control panel frame and reattach the grounding wire.

10. Reattach the 15-pin connector to the interface board.

11. Close and secure the control panel.

6.6.4 Replacing an Ignition Module

1. Unplug the rethermalizer.
2. Remove the screws from the upper corners of the control panel and swing the panel open from the top, allowing it to rest on its hinge tabs.
3. Remove the component box cover by removing the three screws along its bottom edge.
4. Remove the wires from the ignition module one at a time and mark them to facilitate reconnection.
5. Remove the four screws securing the ignition module in place and remove the module from the unit.
6. Remove the four spacers from the back of the old module and insert them into the holes on the new module, tapered end in.
7. Install the new module in the component box and reconnect the wires removed in step 4.
8. Replace component box cover, and close and secure control pane.

6.6.5 Replacing an Ignitor Assembly

1. Unplug the rethermalizer.
2. Remove the ignitor wire and flame sensor wire from the ignitor assembly. Disconnect the gas enrichment tube from the assembly.
3. Remove the two mounting screws and pull the ignitor assembly out of the burner.
4. Install the replacement ignitor assembly, making sure that the ignitor (spark plug) is to the outside.
5. Reconnect the wires and gas enrichment tube.

6.6.6 Replacing the Combustion Air Blower

Refer to Chapter 4, Section 4.4, Clean Combustion Air Blower, for instructions on removing and reinstalling the combustion air blower.

6.6.7 Replacing the Gas Valve

1. Turn off the gas supply to the rethermalizer and unplug the unit.

2. Disconnect the unit from the gas supply line and remove any fitting that may be attached to the gas manifold at the rear of the unit.
3. Disconnect the flexible gas lines at each burner orifice.
4. Disconnect the gas enrichment tubes at the gas valve tee fitting.
5. Disconnect the wires from the gas valve terminal, marking each wire to facilitate reconnection.
6. Remove the two nuts securing the gas manifold bracket to the base frame.
7. Pull the gas manifold assembly out the front of the unit.
8. Remove the gas valve from the manifold assembly and remove all fittings from the old valve.
9. Install the fittings removed from the old valve on the new valve, using Loctite[®] PST56765 or equivalent pipe thread sealant.
10. Apply Loctite[®] PST56765 pipe thread sealant or equivalent to the threads of the manifold and install the new gas valve.
11. Position the gas manifold system in the unit and replace the two nuts removed in step 6.
12. Reverse steps 1-5 to complete installation.
13. Check burner manifold gas pressure in accordance with procedure given in Chapter 4.

6.6.8 Replacing a Burner Assembly

(NOTE: If space permits, it is recommended that the unit be disconnected from the gas line and laid on its back when performing this procedure. Be sure to place blocks under the unit to protect the end of the gas line and the water regulator if this option is selected.)

1. Unplug the rethermalizer.
2. Disconnect the flexible gas line at the burner orifice.
3. Remove both air hoses from the blower assembly and the burner assemblies.
4. Remove the four screws from the blower stabilizing bracket attached to the blower assembly and to each burner. Remove the stabilizing bracket from the unit.
5. Remove the screw securing the blower support bracket to the cookpot assembly and lower the blower assembly out of the way. It is not necessary to disconnect the blower wiring.
6. Remove the two screws at the front of the burner assembly to be replaced, then pull the assembly toward the front of the unit slightly to free it from its rear support. Remove the assembly through the bottom of the unit.

7. Reverse steps 1-6 to install replacement burner assembly, being careful to get the insulation strip running along the top of the blower support bracket back in place.

6.6.9 Replacing the Cookpot

1. Remove the cookpot insert.
2. Remove the top cap by removing the two screws on the front and the screw on each end.
3. Remove the flue cap and lid assembly by removing the two screws on each side and the two outermost screws on the back. Rotate the bottom of the flue cap forward slightly to allow the top of the flue cap to slip out from under the back panel.
4. Remove the four screws securing the upper flue assembly to the back panel.
5. Remove the blower motor by removing the four nuts securing it to blower mounting bracket.
6. Disconnect the flexible gas lines, gas enrichment tubes, ignitor wires, and flame sensor wires from the burner assemblies.
7. Remove the temperature probe from the cookpot. Leave wires attached.
8. Disconnect the water fill line at the cookpot and at the solenoid valve inlet.
9. Disconnect the wires from the water level sensors, marking them to facilitate reconnection.
10. Lift the cookpot assembly out of the cabinet and set it, top down, on a suitable work surface.
11. Remove all other hardware from the old cookpot and install the components on the replacement cookpot, using Loctite[®] PST56765 on the drain valve threads. (NOTE: Install any replacement insulation that might be required before installing components.)
12. Reverse steps 1-10 to install the replacement cookpot.

6.7 Troubleshooting and Problem Isolation

Because it is not feasible to attempt to include in this manual every conceivable problem or trouble condition that might be encountered, this section is intended to provide technicians with a general knowledge of the broad problem categories associated with this equipment, and the probable causes of each. With this knowledge, the technician should be able to isolate and correct any problem encountered.

Problems that are likely to be encountered can be grouped into five broad categories:

1. Ignition failures
2. Improper burner functioning
3. Improper temperature control
4. Computer-related problems
5. Autofill System problems.

The probable causes of each category are discussed in the following sections. A series of Troubleshooting Guides (decision trees) is also included at the end of the chapter to assist in identifying some of the more common problems.

6.7.1 Ignition Failures

Ignition failure occurs when the ignition module fails to sense a flame within a 4-second time delay period and locks out. When this happens, the module sends 24 VAC through the interface board alarm circuit to the computer. The computer then displays `h e l p`.

The three primary reasons for ignition failure, listed in order of probability, are:

1. Problems related to the gas and/or electrical power supplies.
2. Problems related to the electronic circuits.
3. Problems related to the gas valve.

PROBLEMS RELATED TO THE GAS AND/OR ELECTRICAL POWER SUPPLIES

The main indicator of a problem with the electrical power supply is that there are no indicator lights illuminated on the unit. The main indication of a problem with the gas supply is failure of the unit to fire. Verify that the gas line quick-disconnect fitting (if used) is properly connected, the unit is plugged in, the main gas supply valve is open, and the circuit breaker for the unit's electrical supply is not tripped.

PROBLEMS RELATED TO THE ELECTRONIC CIRCUITS

If gas and electrical power are being supplied to the rethermalizer, the next most likely cause of ignition failure is a problem in the 24 VAC circuit. First, verify that the drain valve is fully closed. (The drain valve assembly includes a microswitch that must be closed for power to reach the gas valve. Often, although the valve handle appears to be in the closed position, the microswitch is still open.) If the drain valve is fully closed, refer to the troubleshooting guide **TROUBLESHOOTING THE 24 VAC CIRCUIT**.

Some typical causes of ignition failure in this category include a defective sensing wire in the ignitor assembly, a defective module, a defective ignition wire, or a defective ignitor. Occasionally an ignition failure situation may be encountered in which all components appear to be serviceable and the microamp reading is within specification, but the unit nevertheless goes into ignition failure

during operation. The probable cause in this case is an intermittent failure of an ignition module. When the unit is opened up for troubleshooting, the module cools down enough to operate correctly, but when the unit is again closed up and placed back into service, the module heats up and fails.

PROBLEMS RELATED TO THE GAS VALVE

If the problem is not in the 24 VAC circuit, it is most likely in the gas valve itself, but before replacing the gas valve, refer to the troubleshooting guide **TROUBLESHOOTING THE GAS VALVE**.

6.7.2 Improper Burner Functioning

With problems in this category, the burner ignites but exhibits abnormal characteristics such as “popping,” dark spots on the burner ceramics, fluctuating flame intensity, and flames shooting out of the flue.

“**Popping**” indicates delayed ignition. In this condition, the main gas valve is opening but the burner is not immediately lighting. When ignition does take place, the excess gas “explodes” into flame, rather than smoothly igniting.

The primary causes of popping are:

- Incorrect or fluctuating gas pressure
- A defective, dirty, or incorrectly adjusted combustion air blower
- Inadequate make-up air
- Heat damage to the computer or ignition module
- A cracked ignitor or broken/loose ignition wire
- A defective ignition module
- A cracked burner tile.

If popping occurs only during peak operating hours, the problem is most likely incorrect or fluctuating gas pressure. Verify that the incoming gas pressure (pressure to the gas valve) is in accordance with the following table, and that the pressure remains constant throughout all hours of usage.

| Incoming Gas Pressures | | |
|-------------------------------|----------------|----------------|
| Gas | Minimum | Maximum |
| Natural | 6" W.C. | 14" W.C. |
| | 1.49 kPa | 3.48 kPa |
| | 14.93 mbar | 34.84 mbar |
| LP | 11" W.C. | 14" W.C. |
| | 2.74 kPa | 3.48 kPa |
| | 27.37 mbar | 34.84 mbar |

Refer to **Check Burner Manifold Pressure** in the Semi-Annual Checks and Services section of Chapter 4 for the procedure for checking the gas pressure supplied to the burner.

If popping is consistent during all hours of operation, the most likely cause is an insufficient air supply. Check for “negative pressure” conditions in the kitchen area. If air is flowing into the kitchen area, this indicates that more air is being exhausted than is being replenished, and the burners may be starved for air.

If the rethermalizer’s gas and air supplies are okay, the problem is most likely with one of the electrical components. Examine the ignition module and computer for signs of melting/distortion and/or discoloration due to excessive heat build-up in the equipment. (This condition usually indicates improper flue performance.) A melted or distorted ignition module is automatically suspect and should be replaced, but unless the condition causing excessive heat is corrected, the problem is likely to recur.

Verify that the ignition wire is tightly connected at both ends and free of obvious signs of damage. Again, if damage is due to excessive heat in the equipment, that problem must also be corrected. Check for proper operation by disconnecting the wire from the ignitor, inserting the tip of a screw driver into the terminal, and holding it near the frame of the unit as the power switch is placed in the on position. A strong blue spark should be generated for at least 4 seconds.



Make sure the insulated handle of the screwdriver is held and not the blade. The sparking charge is approximately 25,000 volts.

Examine the ignitor for any signs of cracking. A cracked ignitor must be replaced.

If all other causes have been ruled out, examine the burner tiles for any signs of cracking. If found, the burner must be replaced.

Fluctuating flame intensity is normally caused by either improper or fluctuating incoming gas pressure, but may also be the result of variations in the kitchen atmosphere. Verify incoming gas pressure in the same way as for popping discussed in the preceding paragraphs. Variations in the kitchen atmosphere are usually caused by air conditioning and/or ventilation units starting and stopping during the day. As they start and stop, the pressure in the kitchen may change from positive or neutral to negative, or vice versa. They may also cause changes in airflow patterns that may affect flame intensity.

Dark spots on the burner tiles are the result of an improper air/gas mixture. Adjust the combustion air blower to reduce the amount of air in the mixture to correct this problem.

Flames shooting out of the flue are usually an indication of negative pressure in the kitchen. Air is being sucked out of the burner enclosure and the flames are literally following the air. If negative pressure is not the cause, check for high burner manifold gas pressure in accordance with the procedures in Chapter 4.

An ***excessively noisy burner***, especially with ***flames shooting out of the flue***, may indicate that the gas pressure is too high, or it may simply be that the gas valve vent tube is blocked. If the incoming gas pressure is correct and the vent tube is unobstructed, the gas valve regulator is probably defective.

6.7.3 Improper Temperature Control

Temperature control is a function of several interrelated components, each of which must operate correctly. The principle component is the temperature probe. Other components include the interface board, the water level sensors, the computer, and the ignition module. Whatever the cause, the symptom is failure of the unit to attain or maintain setpoint temperature.

The unit will not call for heat unless the computer senses that the unit is full of water. Sensing is accomplished when the water level in the cookpot contacts the upper water level sensor, grounding it. If the mineral content of the water is unusually low, such as with distilled, purified, or highly filtered water, the water will not ground the sensor. If this is the cause, adding approximately 1/8-cup of baking soda to the water will solve the problem.

Similarly, if the upper water level sensor becomes encrusted with lime, starch, or some other build-up, it will not ground properly. The solution is to clean the water level sensors thoroughly with a Scotchbrite™ or similar nylon scouring pad.

6.7.4 Computer-Related Problems

The computer used in FBKR18 Series rethermalizers is a specially modified Computer Magic III computer, part number 806-9396. Standard CM III computers will not operate this equipment correctly. The first thing to check if problems with the computer are experienced should be the part number.

Most problems concerning the computer have to do with programming it. There are three common complaints. The complaints, their causes, and corrective actions are:

1. Fryer constantly displays HI.

Cause: Setpoint incorrect or missing.

Corrective Action: Press 1650, enter the correct setpoint, then press to lock in the setpoint.

2. Temperature is displayed in Celsius.

Cause: Computer is programmed to display in Celsius.

Corrective Action: Press 1658.

3. Temperature is constantly displayed.

Cause: Computer is programmed for constant temperature display.

Corrective Action: Press i65L.

6.8 Troubleshooting Guides

The troubleshooting guides found in the pages that follow are intended to assist service technicians in quickly isolating the probable causes of equipment malfunctions by following a logical, step-by-step process. An additional set of operator troubleshooting guides is contained in Chapter 5. It is suggested that service technicians thoroughly familiarize themselves with both sets.

6.8.1 Troubleshooting the Gas Valve

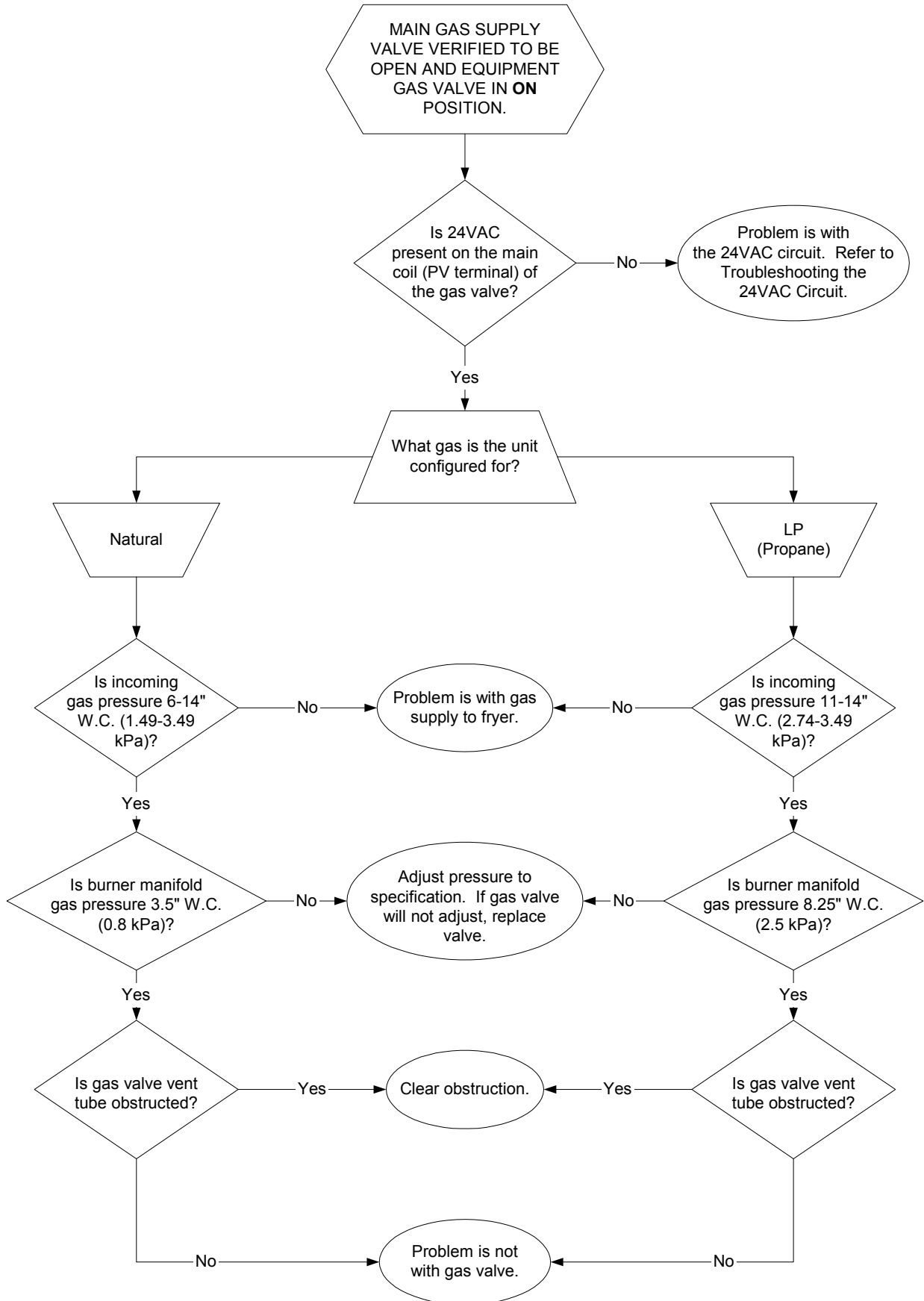

6.8.2 Troubleshooting the 24 VAC Circuit

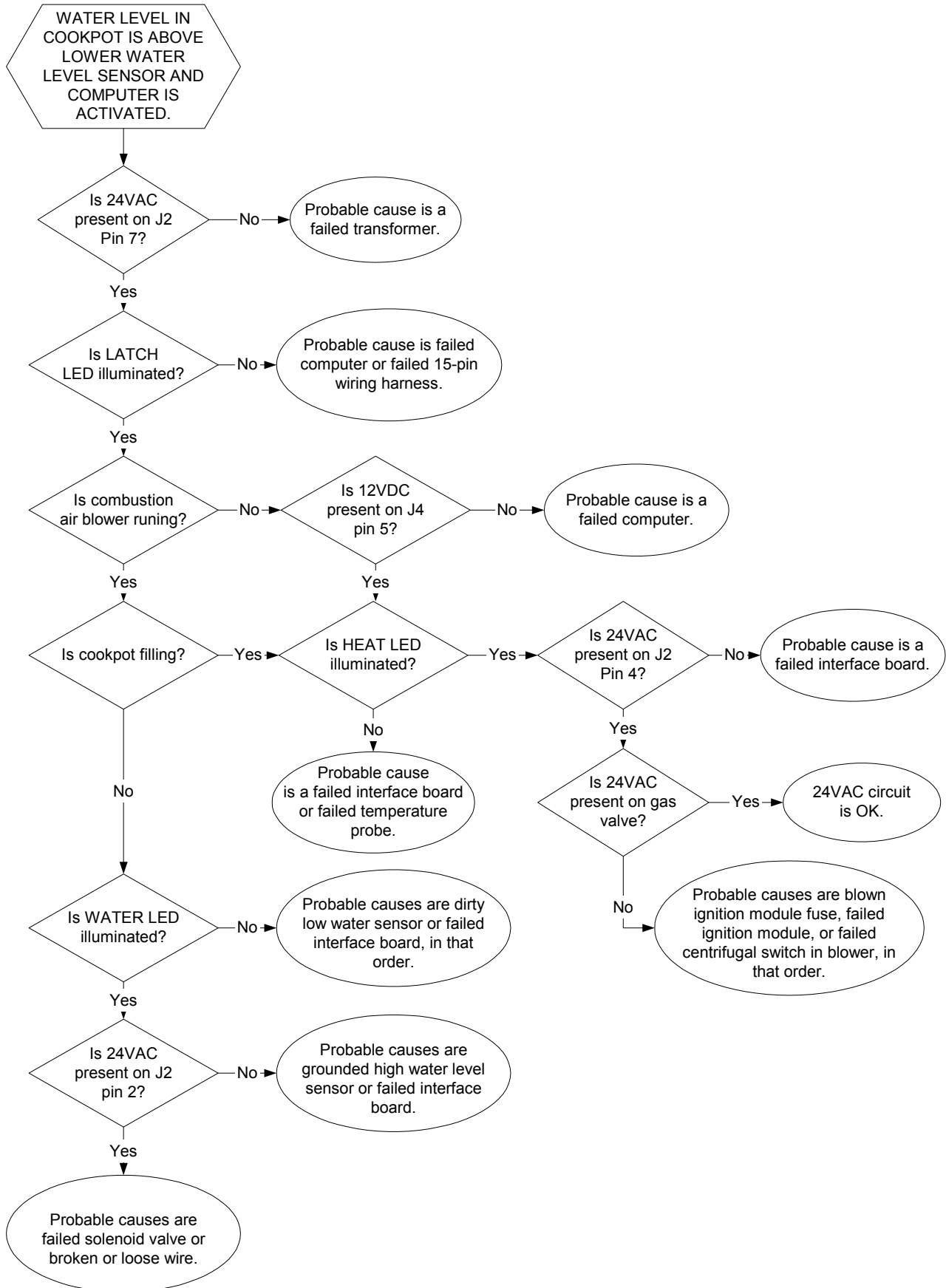

THE 24VAC CIRCUIT

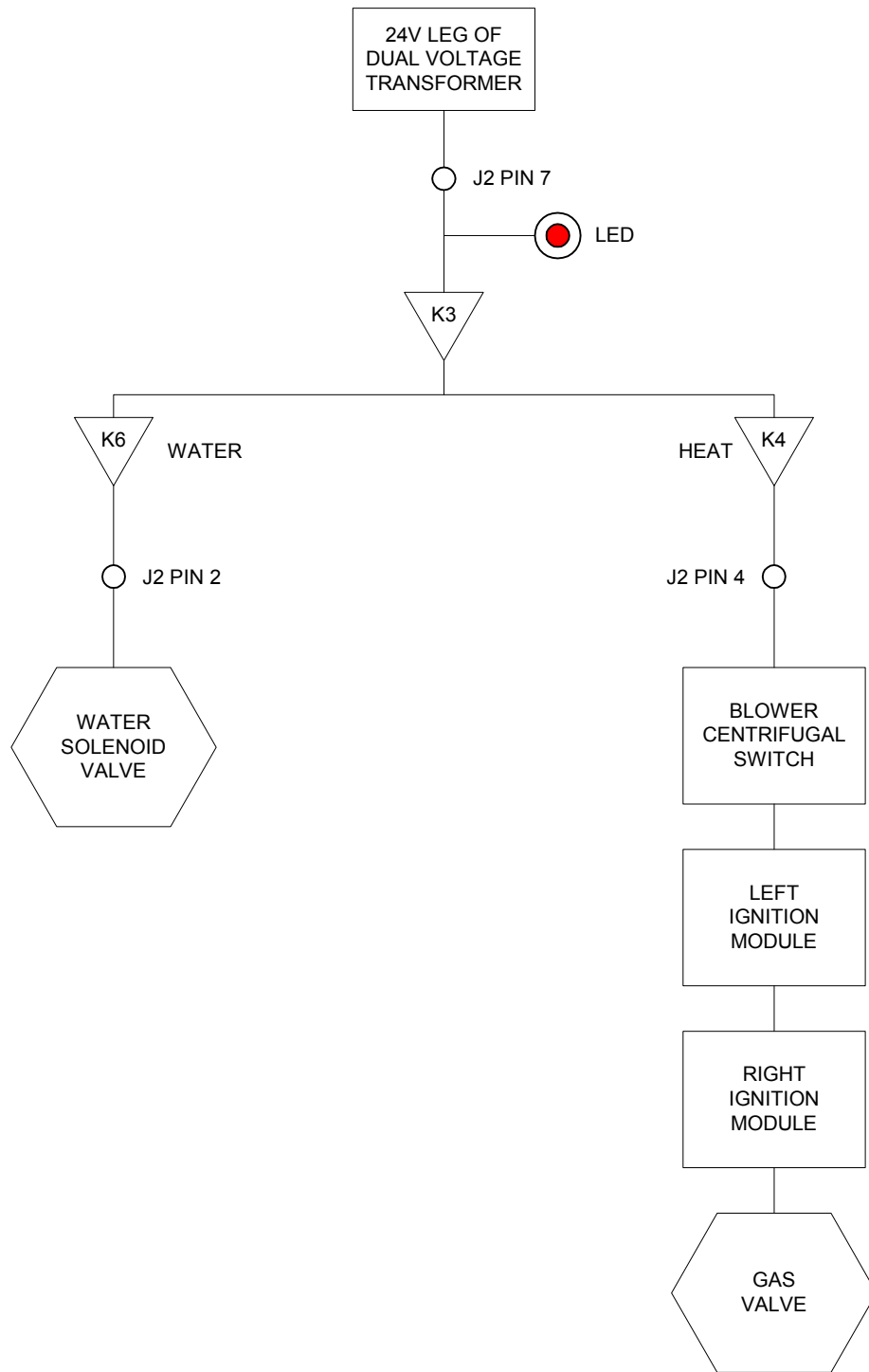

6.8.3 Troubleshooting the Temperature Probe

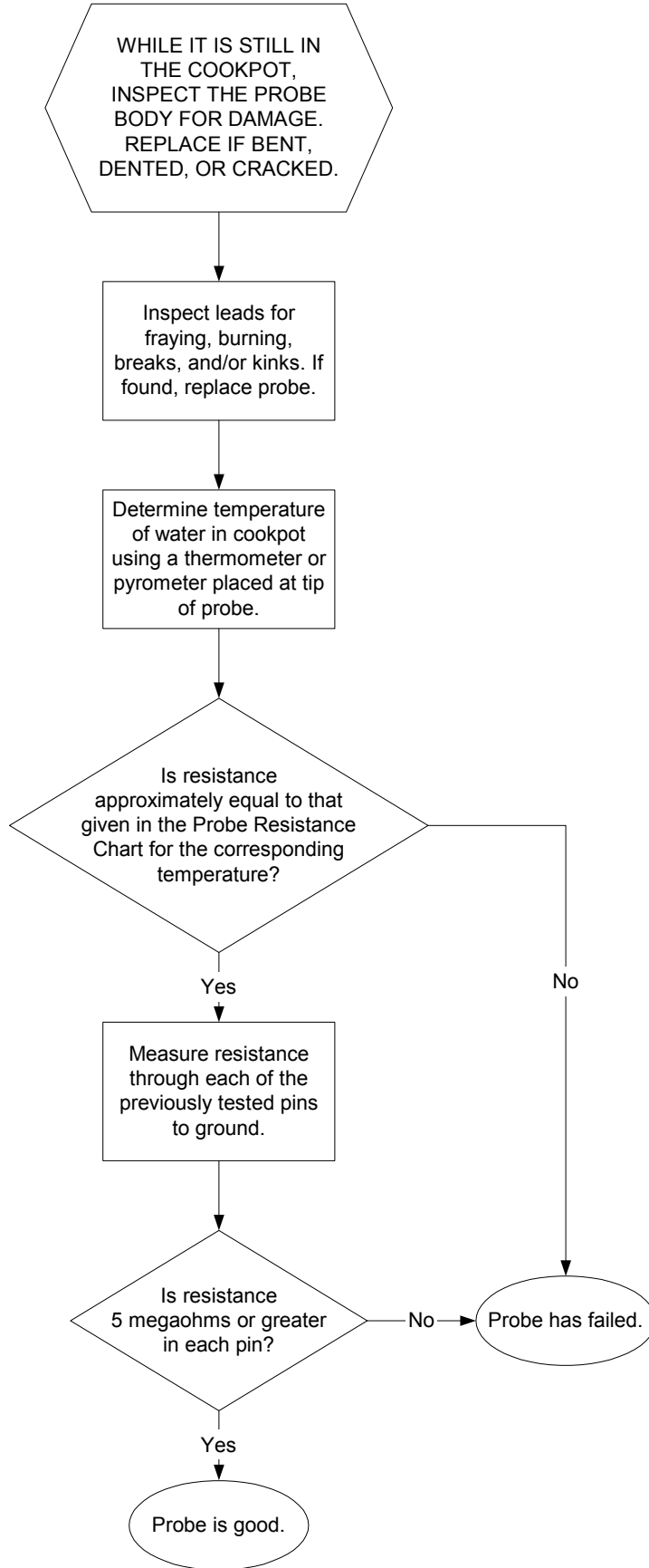

Probe Resistance Chart

| F | OHMS | C | F | OHMS | C | F | OHMS | C | F | OHMS | C | F | OHMS | C |
|----|------|----|-----|------|----|-----|------|----|-----|------|-----|-----|------|-----|
| 32 | 1000 | 0 | 83 | 1107 | 28 | 134 | 1214 | 57 | 185 | 1320 | 85 | 236 | 1424 | 113 |
| 33 | 1002 | 1 | 84 | 1110 | 29 | 135 | 1216 | 57 | 186 | 1322 | 86 | 237 | 1426 | 114 |
| 34 | 1004 | 1 | 85 | 1112 | 29 | 136 | 1218 | 58 | 187 | 1324 | 86 | 238 | 1428 | 114 |
| 35 | 1006 | 2 | 86 | 1114 | 30 | 137 | 1220 | 58 | 188 | 1326 | 87 | 239 | 1430 | 115 |
| 36 | 1008 | 2 | 87 | 1116 | 31 | 138 | 1222 | 59 | 189 | 1328 | 87 | 240 | 1432 | 116 |
| 37 | 1011 | 3 | 88 | 1118 | 31 | 139 | 1224 | 59 | 190 | 1330 | 88 | 241 | 1434 | 116 |
| 38 | 1013 | 3 | 89 | 1120 | 32 | 140 | 1226 | 60 | 191 | 1332 | 88 | 242 | 1436 | 117 |
| 39 | 1015 | 4 | 90 | 1122 | 32 | 141 | 1229 | 61 | 192 | 1334 | 89 | 243 | 1438 | 117 |
| 40 | 1017 | 4 | 91 | 1124 | 33 | 142 | 1231 | 61 | 193 | 1336 | 89 | 244 | 1440 | 118 |
| 41 | 1019 | 5 | 92 | 1126 | 33 | 143 | 1233 | 62 | 194 | 1338 | 90 | 245 | 1442 | 118 |
| 42 | 1021 | 6 | 93 | 1128 | 34 | 144 | 1235 | 62 | 195 | 1340 | 91 | 246 | 1444 | 119 |
| 43 | 1023 | 6 | 94 | 1131 | 34 | 145 | 1237 | 63 | 196 | 1342 | 91 | 247 | 1447 | 119 |
| 44 | 1025 | 7 | 95 | 1133 | 35 | 146 | 1239 | 63 | 197 | 1344 | 92 | 248 | 1449 | 120 |
| 45 | 1030 | 7 | 96 | 1135 | 36 | 147 | 1241 | 64 | 198 | 1346 | 92 | 249 | 1451 | 121 |
| 46 | 1032 | 8 | 97 | 1137 | 36 | 148 | 1243 | 64 | 199 | 1348 | 93 | 250 | 1453 | 121 |
| 47 | 1034 | 8 | 98 | 1139 | 37 | 149 | 1245 | 65 | 200 | 1350 | 93 | 251 | 1455 | 122 |
| 48 | 1036 | 9 | 99 | 1141 | 37 | 150 | 1247 | 66 | 201 | 1352 | 94 | 252 | 1457 | 122 |
| 49 | 1038 | 9 | 100 | 1143 | 38 | 151 | 1249 | 66 | 202 | 1354 | 94 | 253 | 1459 | 123 |
| 50 | 1040 | 10 | 101 | 1145 | 38 | 152 | 1251 | 67 | 203 | 1357 | 95 | 254 | 1461 | 123 |
| 51 | 1042 | 11 | 102 | 1147 | 39 | 153 | 1253 | 67 | 204 | 1359 | 96 | 255 | 1463 | 124 |
| 52 | 1044 | 11 | 103 | 1149 | 39 | 154 | 1255 | 68 | 205 | 1361 | 96 | 256 | 1465 | 124 |
| 53 | 1046 | 12 | 104 | 1151 | 40 | 155 | 1258 | 68 | 206 | 1363 | 97 | 257 | 1467 | 125 |
| 54 | 1049 | 12 | 105 | 1154 | 41 | 156 | 1260 | 69 | 207 | 1365 | 97 | 258 | 1469 | 126 |
| 55 | 1051 | 13 | 106 | 1156 | 41 | 157 | 1262 | 69 | 208 | 1367 | 98 | 259 | 1471 | 126 |
| 56 | 1053 | 13 | 107 | 1158 | 42 | 158 | 1264 | 70 | 209 | 1369 | 98 | 260 | 1473 | 127 |
| 57 | 1055 | 14 | 108 | 1160 | 42 | 159 | 1266 | 71 | 210 | 1371 | 99 | 261 | 1475 | 127 |
| 58 | 1057 | 14 | 109 | 1162 | 43 | 160 | 1268 | 71 | 211 | 1373 | 99 | 262 | 1477 | 128 |
| 59 | 1059 | 15 | 110 | 1164 | 43 | 161 | 1270 | 72 | 212 | 1375 | 100 | 263 | 1479 | 128 |
| 60 | 1061 | 16 | 111 | 1166 | 44 | 162 | 1272 | 72 | 213 | 1377 | 101 | 264 | 1481 | 129 |
| 61 | 1063 | 16 | 112 | 1168 | 44 | 163 | 1274 | 73 | 214 | 1379 | 101 | 265 | 1483 | 129 |
| 62 | 1065 | 17 | 113 | 1170 | 45 | 164 | 1276 | 73 | 215 | 1381 | 102 | 266 | 1485 | 130 |
| 63 | 1067 | 17 | 114 | 1172 | 46 | 165 | 1278 | 74 | 216 | 1383 | 102 | 267 | 1487 | 131 |
| 64 | 1068 | 18 | 115 | 1174 | 46 | 166 | 1280 | 74 | 217 | 1385 | 103 | 268 | 1489 | 131 |
| 65 | 1070 | 18 | 116 | 1176 | 47 | 167 | 1282 | 75 | 218 | 1387 | 103 | 269 | 1491 | 132 |
| 66 | 1072 | 19 | 117 | 1179 | 47 | 168 | 1284 | 76 | 219 | 1389 | 104 | 270 | 1493 | 132 |
| 67 | 1074 | 19 | 118 | 1181 | 48 | 169 | 1287 | 76 | 220 | 1391 | 104 | 271 | 1495 | 133 |
| 68 | 1076 | 20 | 119 | 1183 | 48 | 170 | 1289 | 77 | 221 | 1393 | 105 | 272 | 1497 | 133 |
| 69 | 1078 | 21 | 120 | 1185 | 49 | 171 | 1291 | 77 | 222 | 1395 | 106 | 273 | 1499 | 134 |
| 70 | 1080 | 21 | 121 | 1187 | 49 | 172 | 1293 | 78 | 223 | 1398 | 106 | 274 | 1501 | 134 |
| 71 | 1082 | 22 | 122 | 1189 | 50 | 173 | 1295 | 78 | 224 | 1400 | 107 | 275 | 1503 | 135 |
| 72 | 1084 | 22 | 123 | 1191 | 51 | 174 | 1297 | 79 | 225 | 1402 | 107 | 276 | 1505 | 136 |
| 73 | 1086 | 23 | 124 | 1193 | 51 | 175 | 1299 | 79 | 226 | 1404 | 108 | 277 | 1507 | 136 |
| 74 | 1089 | 23 | 125 | 1195 | 52 | 176 | 1301 | 80 | 227 | 1406 | 108 | 278 | 1509 | 137 |
| 75 | 1091 | 24 | 126 | 1197 | 52 | 177 | 1303 | 81 | 228 | 1408 | 109 | 279 | 1512 | 137 |
| 76 | 1093 | 24 | 127 | 1199 | 53 | 178 | 1305 | 81 | 229 | 1410 | 109 | 280 | 1514 | 138 |
| 77 | 1095 | 25 | 128 | 1201 | 53 | 179 | 1307 | 82 | 230 | 1412 | 110 | 281 | 1516 | 138 |
| 78 | 1097 | 26 | 129 | 1204 | 54 | 180 | 1309 | 82 | 231 | 1414 | 111 | 282 | 1518 | 139 |
| 79 | 1099 | 26 | 130 | 1206 | 54 | 181 | 1311 | 83 | 232 | 1416 | 111 | 283 | 1520 | 139 |
| 80 | 1101 | 27 | 131 | 1208 | 55 | 182 | 1313 | 83 | 233 | 1418 | 112 | 284 | 1522 | 140 |
| 81 | 1103 | 27 | 132 | 1210 | 56 | 183 | 1315 | 84 | 234 | 1420 | 112 | 285 | 1524 | 141 |
| 82 | 1105 | 28 | 133 | 1212 | 56 | 184 | 1317 | 84 | 235 | 1422 | 113 | 286 | 1526 | 141 |

6.9 Simplified Wiring Diagrams

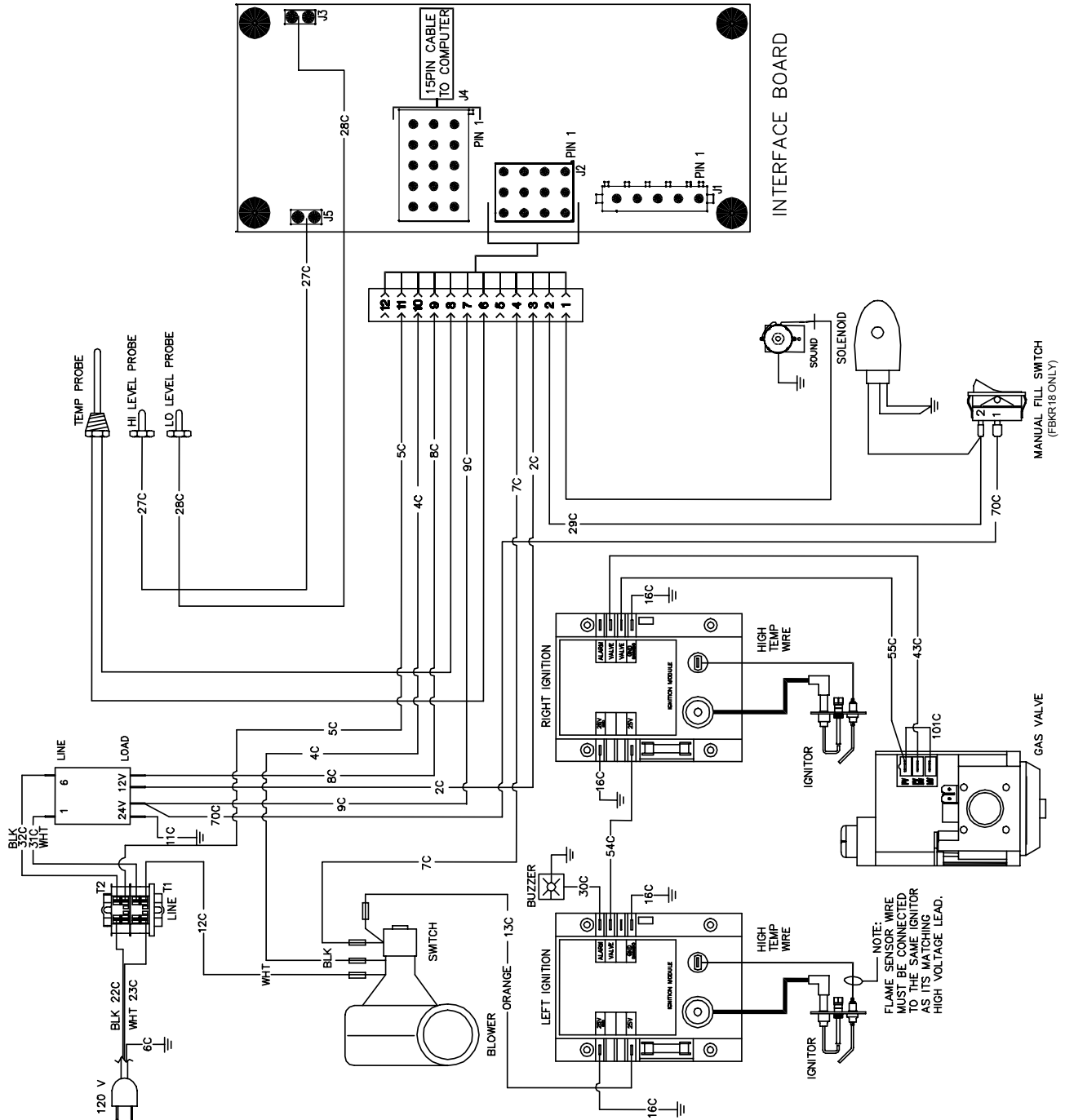

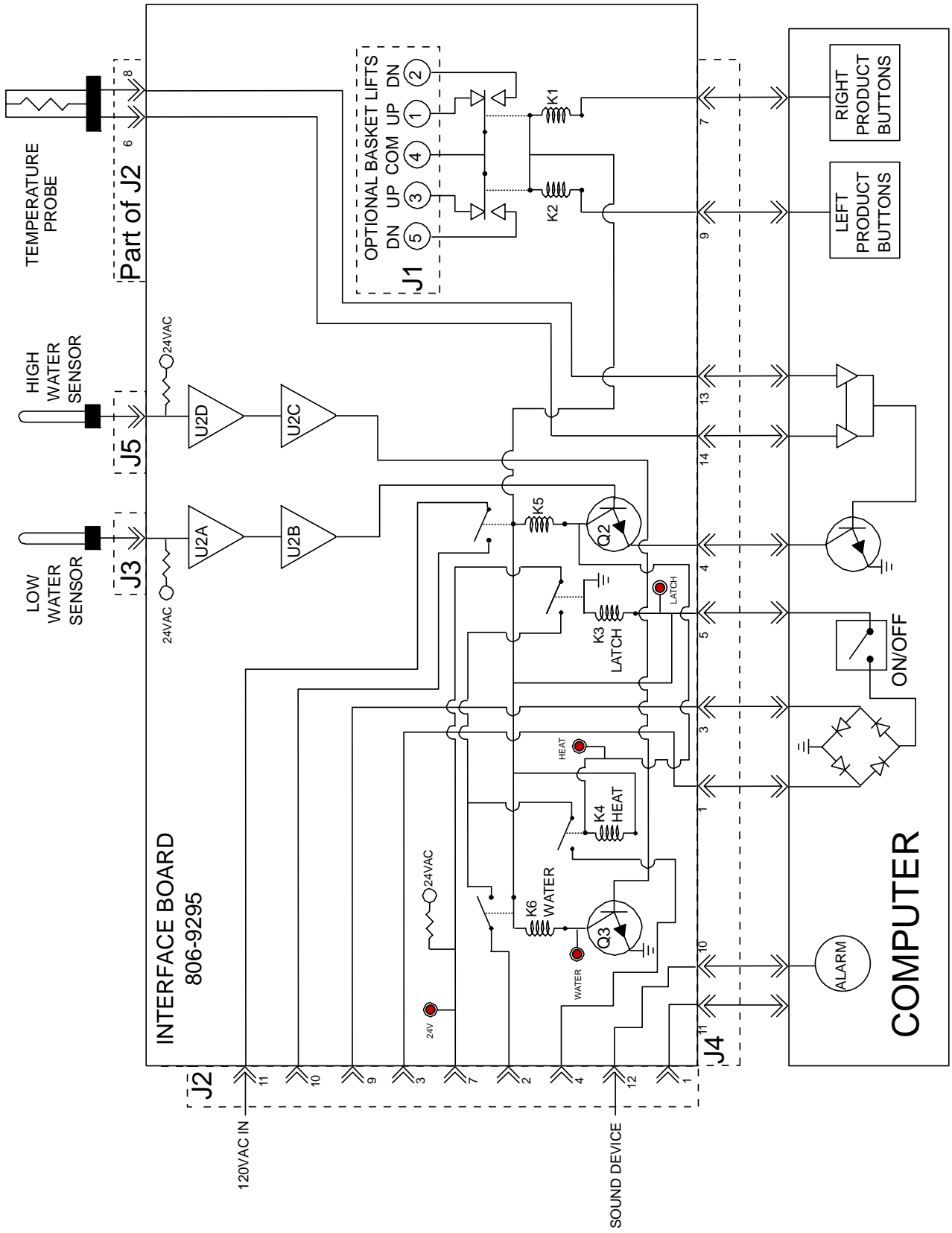

FBCR18 & FBKR18 SERIES GAS RETHERMALIZERS

CHAPTER 7: PARTS LIST

7.1 Burner System Components

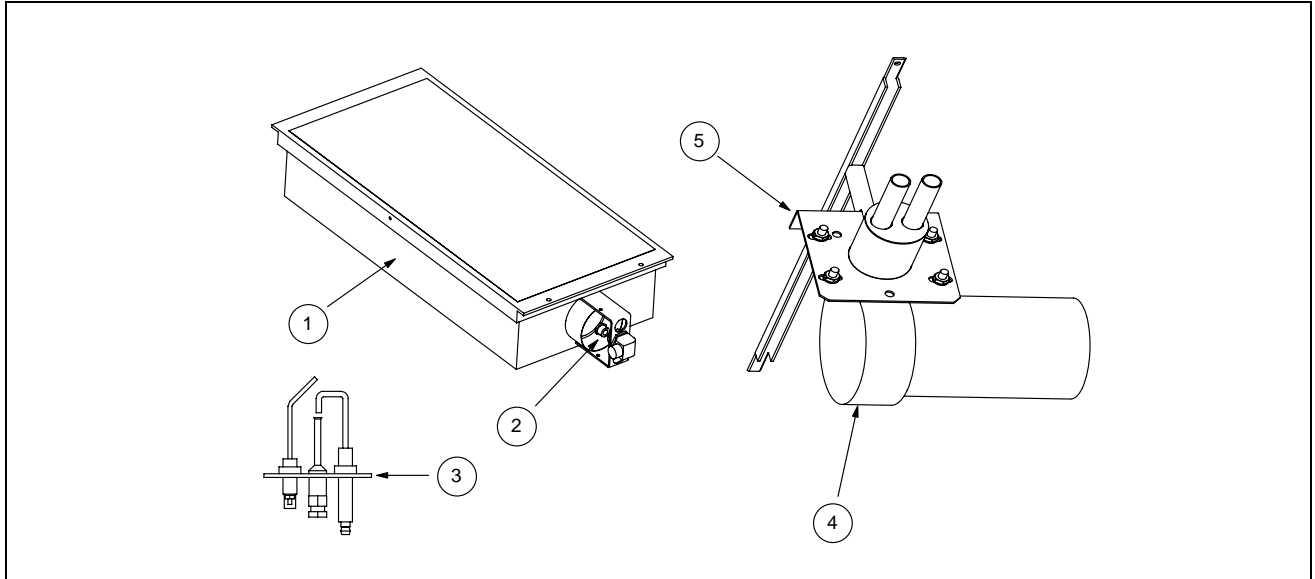

| ITEM | PART # | COMPONENT |
|------|------------|--|
| | | Burner Assemblies |
| | 806-5563 | Natural Gas, Complete |
| | 806-5564SP | Propane Gas, Complete |
| 1 | 810-1382 | Burner, Reverse Plenum, Universal |
| 2 | | Orifice |
| | 810-0916 | Natural Gas, 3.26mm |
| | 810-0917 | Propane Gas, 2.00mm |
| 3 | | Ignitor and Insulation Kit |
| | 826-1714 | Natural Gas |
| | 826-1715 | Propane Gas |
| 4 | 807-1564 | Blower, Combustion Air, 120V <i>(for 230/240V units, use 807-1712)</i> |
| 5 | 823-2528 | Mount, Combustion Air Blower |
| * | 816-0055 | Insulation, Blower Mount |
| * | 900-5525 | Bracket, Combustion Air Blower Stabilizer |
| * | 810-0507 | Spacer, Combustion Air Blower Mount, .23 x .75 |
| * | 807-1878 | Ignitor Wire, 19-inch |
| * | 816-0165 | Insulation, Ignitor |
| * | W82C1SP | Flame Sensor Wire |
| * | 816-0278 | Hose, Air, 5/8-inch ID |
| * | 810-1353 | Flexline, SS, 9-inch |
| * | 810-1354 | Flexline, SS, 12-inch |
| * | 811-0800 | Enrichment Tube, 12.5-inch |

* Not illustrated.

7.2 Cabinetry and Associated Components

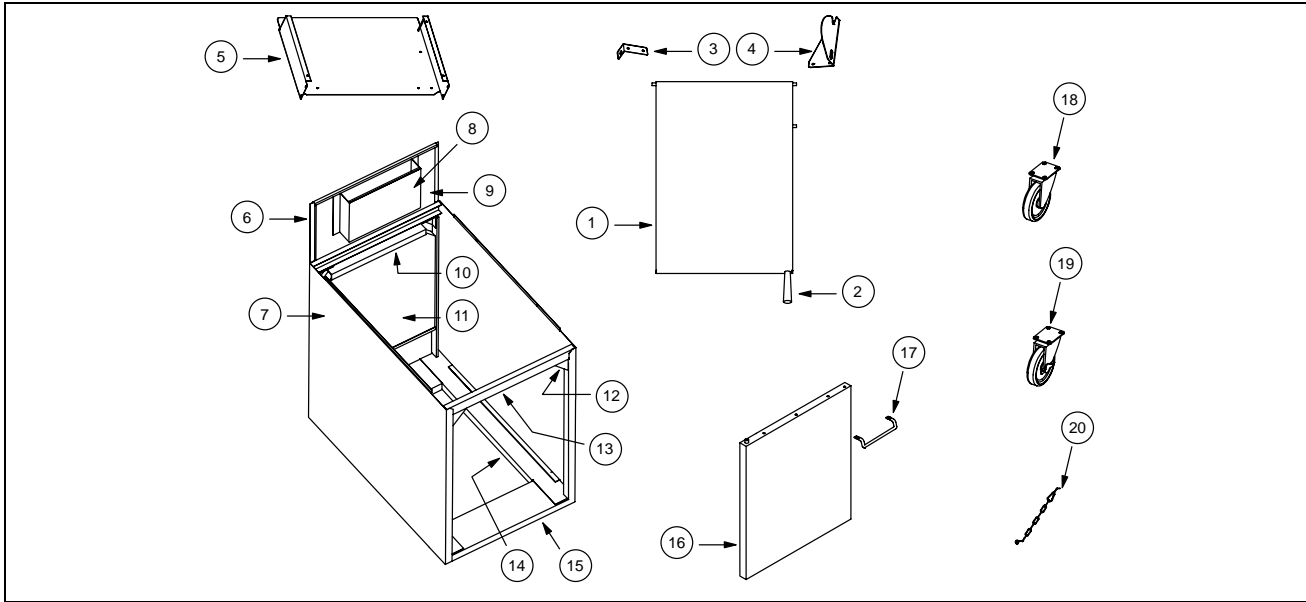

| ITEM | PART # | COMPONENT |
|------|----------|---|
| 1 | 806-8060 | Cover Assembly w/Handle |
| 2 | 810-1374 | Handle, Cover |
| 3 | 910-5246 | Bracket, Cover |
| 4 | 910-5303 | Bracket, Cover Support |
| 5 | 823-2881 | Flue Cap |
| 6 | 900-5737 | Back, Cabinet |
| 7 | 900-7377 | Side, Cabinet, CRS <i>(for S/S units, use 910-7377)</i> |
| 8 | 900-5293 | Flue Extension, Cabinet Back |
| 9 | 816-0158 | Insulation, Upper Cabinet Back |
| 10 | 900-4521 | Retainer, Cabinet Back Insulation |
| 11 | 812-1141 | Insulation, Cabinet Back |
| 12 | 900-1552 | Gusset |
| 13 | 900-4505 | Top Brace |
| 14 | 900-7376 | Channel, Base Side |
| 15 | 900-4504 | Channel, Base Front/Rear |
| 16 | 806-3853 | Door Assembly |
| 17 | 810-1442 | Handle, Wireform Door |
| 18 | 810-0356 | Caster, 5-inch Wheel, w/o Brake |
| 19 | 810-0357 | Caster, 5-inch Wheel, w/Brake |
| 20 | 826-0900 | Chain Restraint Kit (for units having casters) |
| * | 826-1095 | Anchor Strap Kit (for units having legs) |
| * | 824-0606 | Top Cap |
| * | 806-5209 | Caster Pad/Leg Pad Assembly |
| * | 826-1043 | Caster/Leg Mounting Hardware Kit |
| * | 806-3811 | Leg Kit (contains 4 legs) |
| * | 910-8403 | Insert, Cookpot Trim (FBKR18 Only) |

* Not illustrated.

7.3 Computer, Component Box Assembly, and Associated Parts

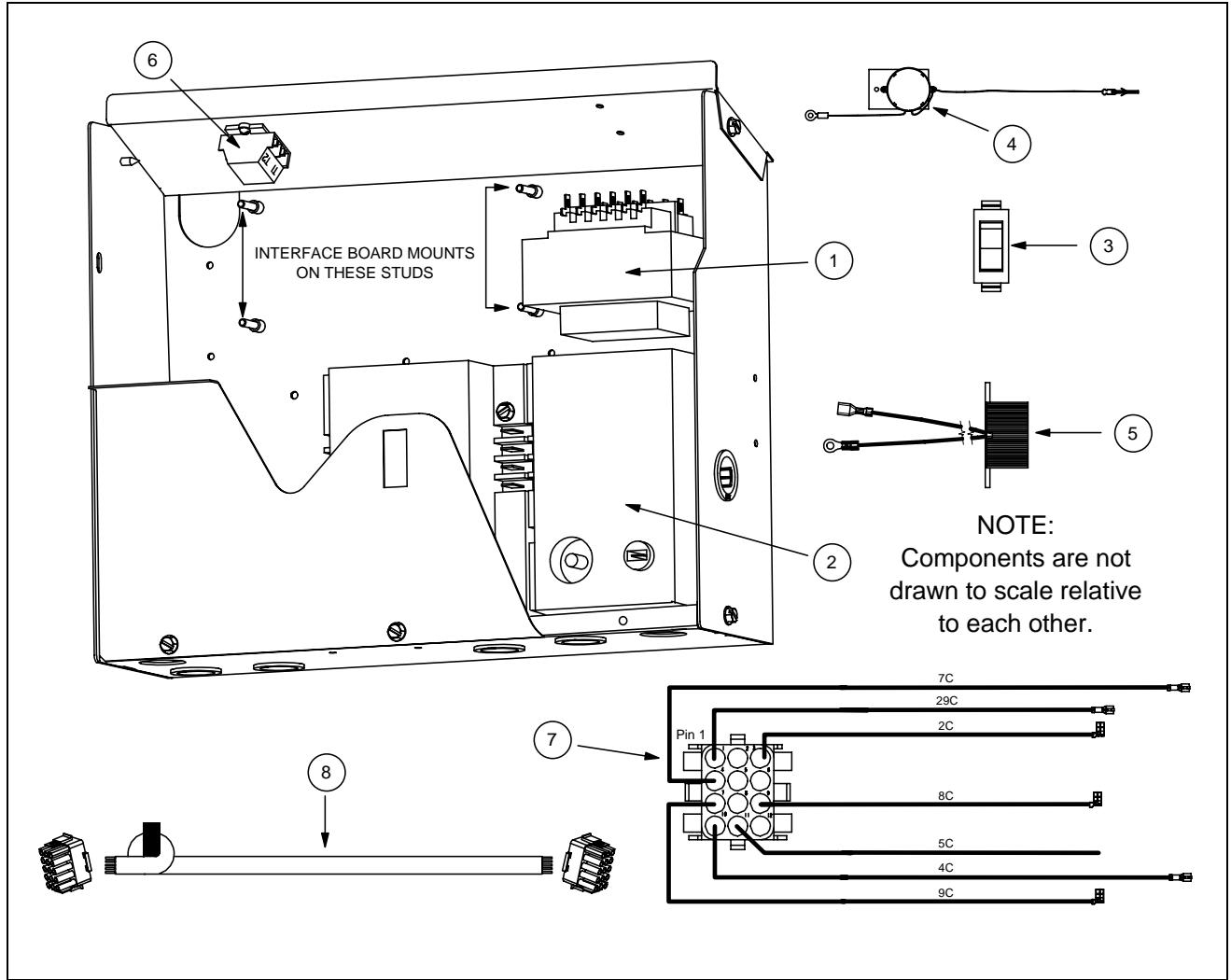

| ITEM | PART # | COMPONENT |
|------|----------|--|
| * | 106-0769 | Computer, CM III (for use on FBCR18 Series rethermalizer only) |
| * | 806-9352 | Computer, CM III (for use on FBKR18 Series rethermalizer only) |
| * | 806-9295 | Interface Board |
| * | 807-0154 | Cordset, 120VAC |
| * | 809-0349 | Spacer, 4mm x 6mm Aluminum Interface Board Standoff |
| * | 809-0446 | Spacer, Ignition Module Standoff |
| 1 | 807-2176 | Transformer, V/F Dual Voltage |
| 2 | 807-1006 | Module, 4-Second Honeywell Ignition |
| 3 | 807-2659 | Switch, Momentary (Manual Fill Switch) |
| 4 | 807-1713 | Sound Device (Operator Alert) |
| 5 | 806-4797 | Buzzer Assembly (Ignition Failure Alarm) |
| 6 | 810-1164 | Terminal Block, 1-piece |
| 7 | 806-9286 | Harness, 12-pin Wiring |
| 8 | 806-2071 | Harness, 15-pin Wiring |

* Not illustrated.

7.4 Cookpot and Associated Parts

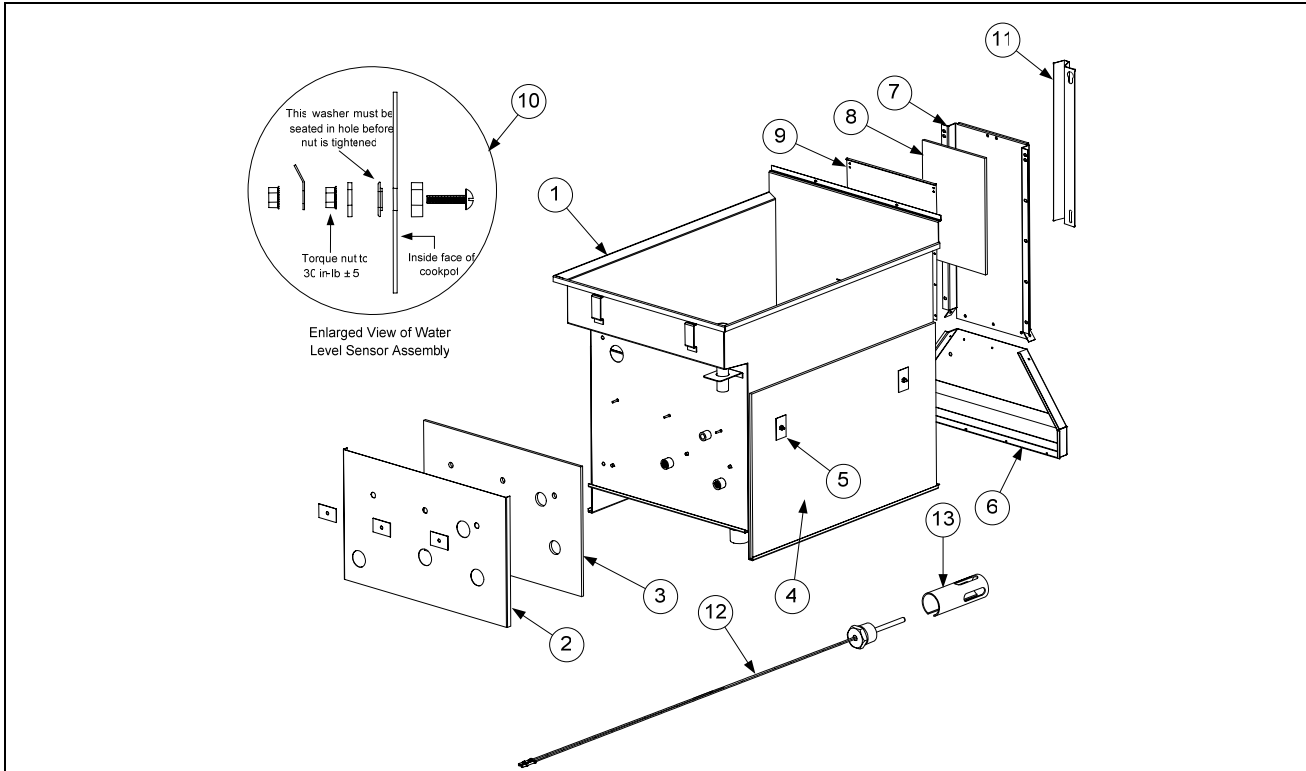

| ITEM | PART # | COMPONENT |
|------|------------|--|
| 1 | | Cookpot Assembly (includes flue, insulation, burners and blower) |
| | 106-2792 | Natural Gas (for bare cookpot only, order 823-4088SP) |
| | 106-2793 | LP (Propane) Gas (for bare cookpot only, order 823-4088SP) |
| 2 | 900-5282 | Cover, Front Insulation |
| 3 | 816-0270 | Insulation, Cookpot Front |
| 4 | 816-0144 | Insulation, Cookpot Side |
| 5 | 900-1762 | Retainer, Insulation |
| 6 | 823-2005 | Flue |
| 7 | 900-1893 | Flue Extension, Cookpot |
| 8 | 816-0271 | Insulation, Flue |
| 9 | 900-1894 | Flue Extension, Cookpot, Rear |
| 10 | 806-7552SP | Sensor Assembly, Upper or Lower Water Level |
| 11 | 910-5196 | Cover, Water Level Sensors |
| 12 | 806-4206 | Probe Assembly, Temperature |
| 13 | 210-0681 | Guard, Probe |
| * | 814-0048 | Sight Glass |
| * | 900-1031 | Retainer, Sight Glass |
| * | 816-0053 | Insulation, Sight Glass |
| * | 816-0145 | Insulation, Cookpot Side (14.50" x 3.00") |
| * | 816-0166 | Insulation, Rear Bottom (17.00" x 3.50") |
| * | 812-0357 | Insulation, Burner (40.00" x 0.62") |

* Not illustrated.

7.5 Gas Supply Components

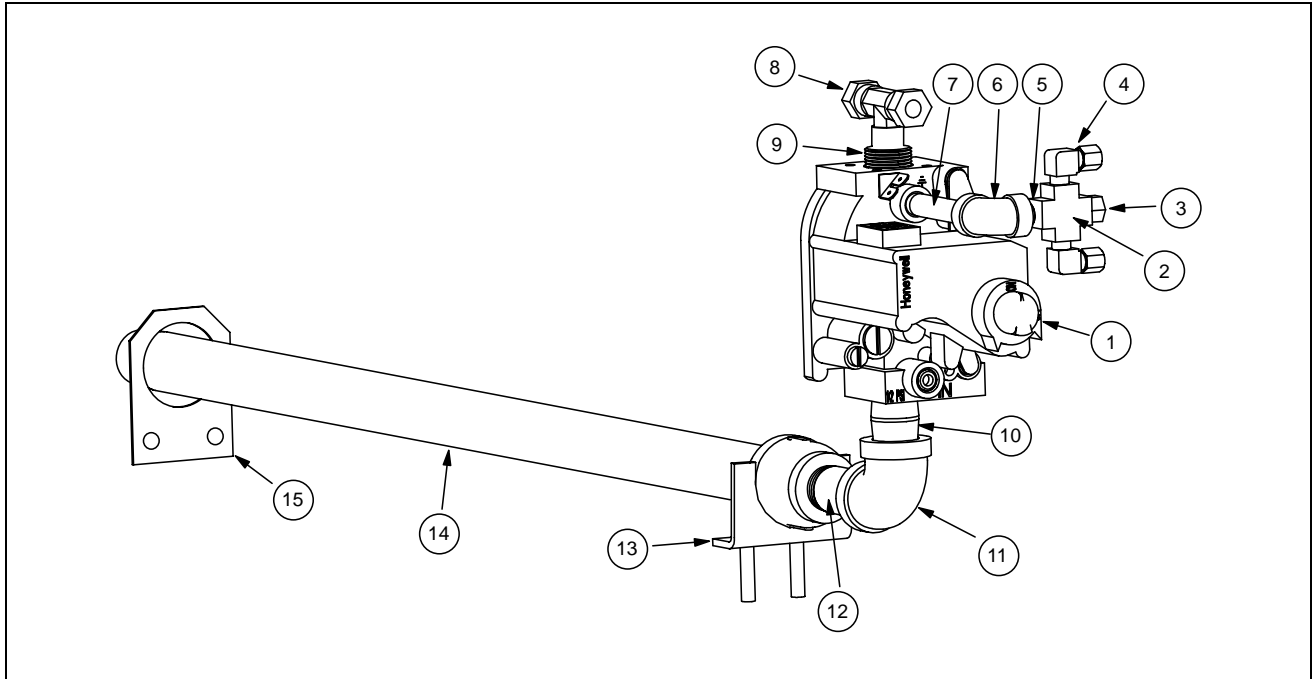

| ITEM | PART # | COMPONENT |
|------|----------|--|
| 1 | | Gas Valve |
| | 810-0786 | Natural Gas |
| | 810-0787 | LP (Propane) Gas |
| 2 | 813-0378 | Fitting, Cross, 1/8" NPT, Brass |
| 3 | 813-0154 | Plug, Pipe, 1/8" Hex Head |
| 4 | 813-0354 | Elbow, 1/8" NPT x 90° x 1/8" Tube, Brass |
| 5 | 813-0016 | Nipple, 1/8" x 3/4" NPT, BM |
| 6 | 813-0004 | Elbow, 1/8" NPT x 90°, BM |
| 7 | 813-0433 | Nipple, 1/8" NPT x 2 1/2", BM |
| 8 | 813-0304 | Bushing, 1/2" x 1/4" Flush, BM |
| 9 | 813-0301 | Tee, Male, 3/8" x 1/4" NPT x 3/8", Brass |
| 10 | 813-0022 | Nipple, 1/2" NPT Close, BM |
| 11 | 813-0062 | Elbow, 1/2" x 90°, BM |
| 12 | 813-0265 | Nipple, 1/2" NPT x 2 1/2", BM |
| 13 | 823-2766 | Mounting Bracket, Gas Line |
| 14 | 813-0257 | Nipple, 3/4" NPT x 24 1/2", BM |
| 15 | 900-1761 | Bracket, Rear Manifold |

7.6 Plumbing Components

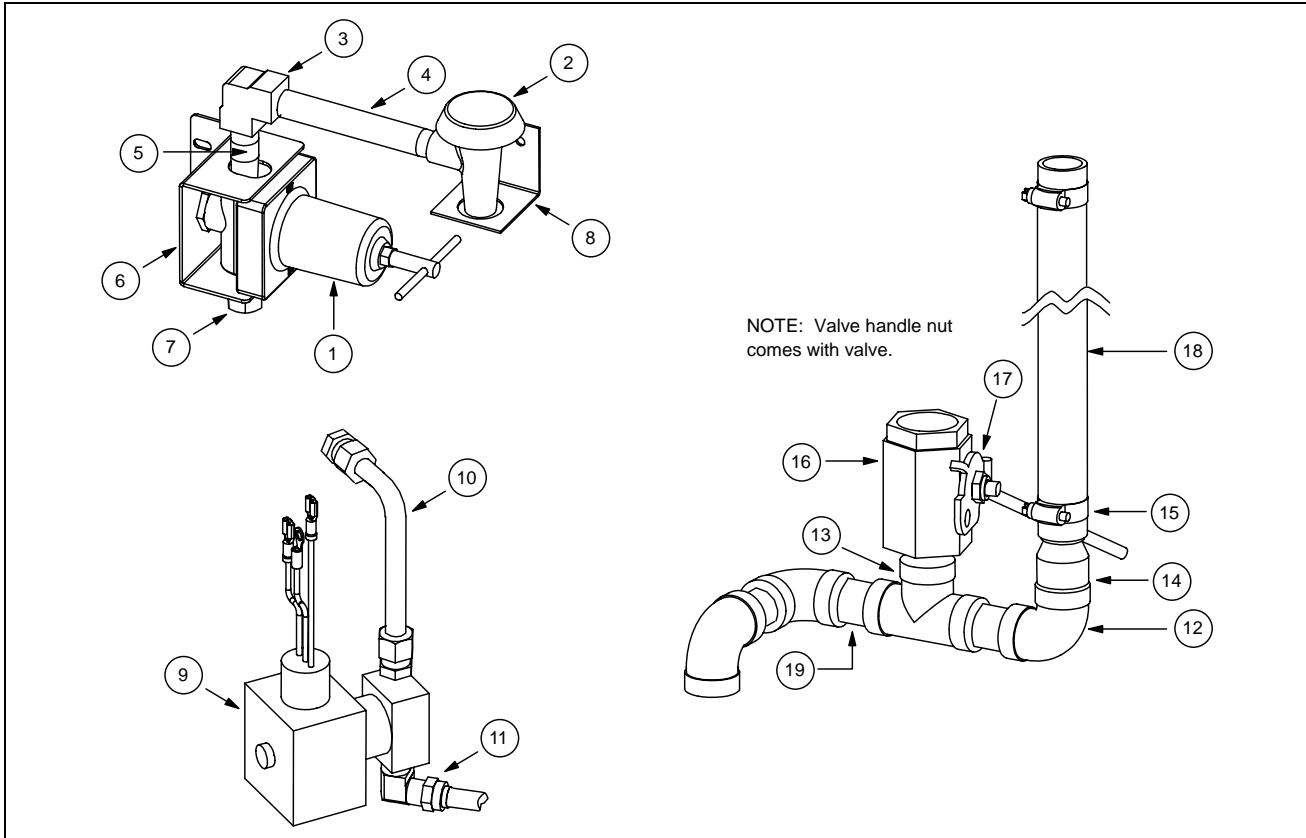

| ITEM | PART # | COMPONENT |
|------|----------|---|
| 1 | 810-1208 | Valve, Water Pressure Regulator |
| 2 | 810-1351 | Vacuum Breaker |
| 3 | 813-0448 | Elbow, 1/4", Brass |
| 4 | 813-0473 | Nipple, 1/4" x 4.0", Brass |
| 5 | 813-0471 | Nipple, 1/4" x 1.5", Brass |
| 6 | 900-2916 | Bracket, Water Pressure Regulator Valve |
| 7 | 810-1025 | Compression Fitting, 1/4", Straight |
| 8 | 900-5210 | Bracket, Vacuum Breaker |
| 9 | 806-5565 | Valve Assembly, Solenoid |
| 10 | 910-5228 | Tubing, Pot to Solenoid, SS |
| 11 | 810-1372 | Fitting, 90°, 1/4" NPT x 3/8" Tube |
| 12 | 813-0202 | Elbow, 1" NPT x 90°, BM |
| 13 | 813-0314 | Tee, 1" NPT, BM |
| 14 | 813-0525 | Fitting, Barbed, 1" NPT Pipe to Hose |
| 15 | 809-0374 | Clamp, Hose |
| 16 | 810-1824 | Valve, Drain |
| 17 | 910-9527 | Handle, Drain Valve |
| 18 | 816-0372 | Hose, Drain |
| 19 | 813-0138 | Nipple, Close, 1" NPT |



Enodis[®]
One Company, Countless Solutions

Frymaster, L.L.C., 8700 Line Avenue, PO Box 51000, Shreveport, Louisiana 71135-1000
Shipping Address: 8700 Line Avenue, Shreveport, Louisiana 71106

TEL 1-318-865-1711 FAX (Parts) 1-318-219-7140 FAX (Tech Support) 1-318-219-7135

PRINTED IN THE UNITED STATES

SERVICE HOTLINE
1-800-551-8633

Price: \$10.00
819-5686
March 2005