

# IPW-1A

## Intercom-Over-IP Adaptor

### - INSTRUCTIONS -

The IPW-1A offers voice-quality Intercom function over standard IP based networks. Designed specifically to integrate seamlessly into a new or existing LAN / WAN infrastructure, the IPW-1A system is capable of supporting hundreds of stations. Providing intercom/paging solutions to a large variety of applications including commercial, industrial, residential, general security, office, and institutional.

## 1 NAMES & FEATURES

### IPW-1A

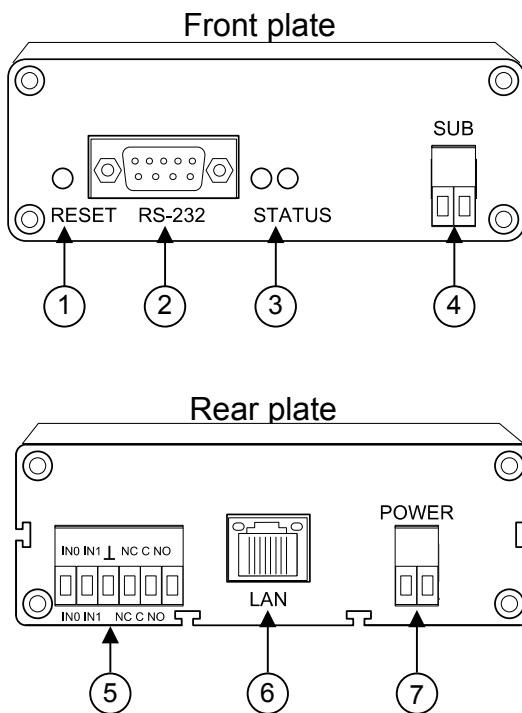

### NAMES & FUNCTIONS:

1. Reset switch (reset unit)
2. RS-232 Serial Port (for firmware recovery)
3. Green and Red Status Lights
4. Sub station connector
5. Door release relay output & external input.  
 Door release:  
 NC = Normally closed contact  
 NO = Normally open contact  
 C = Common
6. RJ-45 10/100 ethernet jack & connection indicator LED's (network connection)
7. Power input connector

### Package Contents:

- (1) IPW-1A
- (1) PT-1211C
- (1) Mounting hardware
- (1) Software CD
- (1) Install manual

### FEATURES:

- Cost-effective multi-master (PC-based) based design
- Compatible with IE Series sub stations and AX-DM
- Scalable to hundreds of stations / locations
- Works with standard wired and wireless network infrastructure. (LAN/WAN)
- Digital audio recording and playback capability via included software.
- Relay output for remote release (N/O or N/C)

## 2 INSTALLATION & MOUNTING

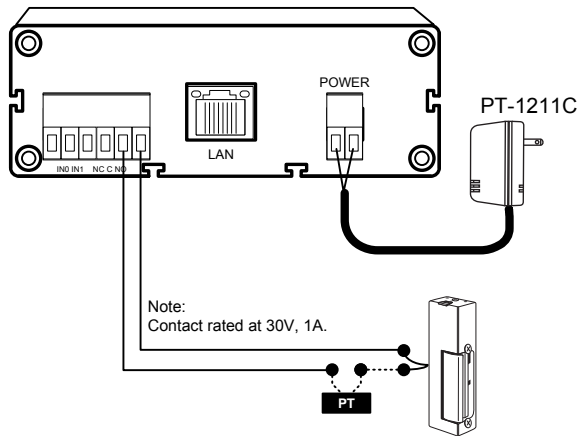

### Installation Instructions:

1. If the IPW-1A adaptor is not on the same LAN or network segment as the PC master station, ensure that the IPW-1A has been pre-programmed with the proper connection settings prior to physical adaptor installation. See the CommuniCenter Operations manual (included on CD with IPW-1A).
2. Wire the sub station to the proper connector on the IPW-1A, and connect to the network using the standard RJ-45 jack. Wiring from the sub station to the IPW-1A should be a 2-conductor, shielded cable. Connect the PT-1211C power supply included to the power input connector.

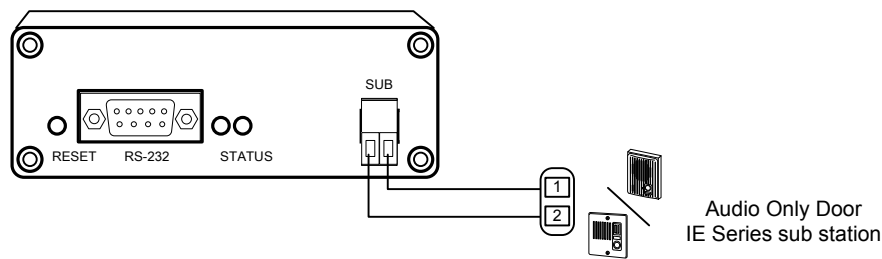

- \* Wiring to sub station should be 2-conductor shielded cable.  
Wire distance from IPW-1A to IE series sub station:  
22AWG = 387 feet, 18AWG = 980 feet

### Mounting Instructions:

1. Mount the IPW-1A adaptor in a controlled area or in an enclosure suitable to the installation environment. The IPW-1A chassis is **neither vandal resistant nor weather resistant**. Secure the provided mounting bracket and then slide the IPW-1A onto the bracket as shown. If mounting the unit on a shelf, attach the 4 rubber feet that are included.

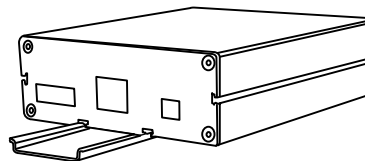
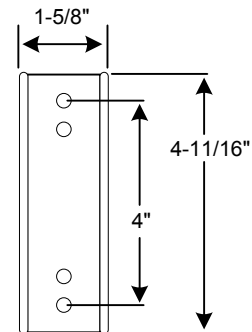

## 3 CommuniCenter SOFTWARE INSTALLATION

1. Load the software onto the PC to be used as a master station. Insert the CD (included with IPW-1A) or download the latest version from the Aiphone website ([www.aiphone.com](http://www.aiphone.com)).
2. Install the CommuniCenter software by following the on-screen prompts, or by executing "**setup.exe**" to begin the installation process.
3. Consult the CommuniCenter Operation manual document for further software functionality and configuration information.

NOTE – If installing system over a WAN please refer to the CommuniCenter Operation manual.

# 4 STATION SET-UP

## DHCP Enabled:

- An IP address will automatically be assigned to each IPW-1A with the default **ID#** as 0 and **Location Name** left blank.
- Right click on each station to open the drop down box, and select **Settings**. This will open the **Hardware Configuration** tool. Give each adaptor a unique **ID#** along with a unique **Location Name**.

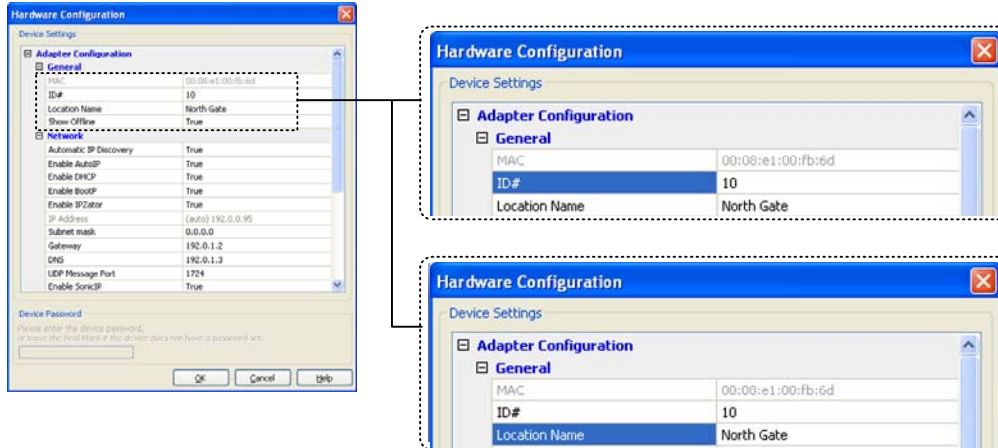

- It is recommended that a password be set for each adaptor. This password can be the same for all adaptors in the LAN if you wish. To set the password, right click on the device and select **Launch in browser**. Under Security Settings, enter a password of your choosing in the **Set Password** field and select Apply. Once set, this password must be entered before any changes can be made in the **Hardware Configuration** tool, or web interface.

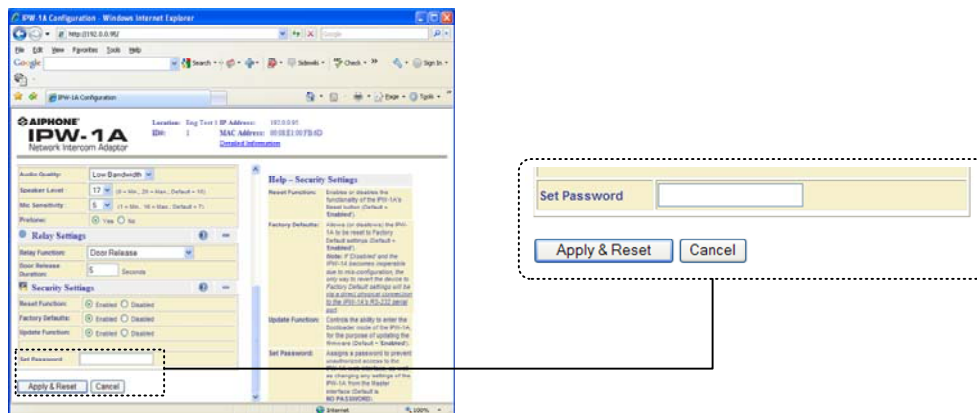

# 5 HARDWARE DIAGNOSTICS

## RED and GREEN LEDs next to RS-232 Serial Port

### Unit powering up:

- While the unit is searching for its IP address, the Red LED and Green LED will blink alternately. In the absence of a DHCP server any network activity during this time should allow it to get an IP address, such as opening a web browser.
- Upon finding its IP address, the IPW-1A will use SonicIP to verbally announce that address. At this time the Red LED will blink.
- If an error is detected, the Red LED will remain on, then the Green LED will blink three or five times depending on the error. Upon blinking the error message, the unit will reset itself. It will blink five times if the firmware is corrupt or if there is an IP address conflict. It will blink three times if the network hardware could not be initialized, or if there is a corrupt MAC address.

**Device running / normal operation:**

- During normal operation, the Green LED will remain on while the Red LED will remain off.

**Pushing the reset button:**

- Upon pressing the reset button, the Green LED and Red LED will remain on. If the reset button is held for 10 seconds or more, the Green LED will remain lit and the Red LED will blink, resetting the unit to factory defaults.

**Ethernet jack LED status**

Yellow: link is established

Green: connected to 10Mbit network

Orange: connected to 100Mbit network

## 6 SPECIFICATIONS

---

**Hardware Specifications:**

Input Voltage:	Use Aiphone PT-1211C (included); 15-24V AC/DC
Network Interface:	10/100 Base-T Ethernet (Auto detection) RJ-45
IP Assignment:	Static or Dynamic
Hardware Protocols:	TCP/IP, UDP, DHCP, SNMP, AutoIP, SonicIP, Ipzator Contact Aiphone for additional supported protocols
Transport Bandwidth:	≈128Kbps per active session (normal mode) ≈64Kbps per active session (low bandwidth mode)
Audio Encoding:	PCM (raw), G.711 (μLaw)
Audio Sampling:	16bit at 8kHz (normal mode) 8bit at 8kHz (low bandwidth mode)
Output Level:	Determined by sub station
Relay Contact Rating:	30V AC/DC 1.0A (resistive)
Operating temperature:	32°F to 104°F (0°C to 40°C)
Dimensions:	1-1/2"H x 4-1/4"W x 4-15/16"D

**Software System Requirements:**

For optimum performance of the CommuniCenter program, we recommend the following minimum requirements:

Operating System:	Microsoft Windows <sup>®</sup> XP (SP2), Windows Vista <sup>®</sup>
Processor:	1 GHz or faster
Memory:	256MB of RAM
Hard drive:	50MB of available disk space
Sound Card:	Windows supported sound card (w/ speaker & microphone)

**WARRANTY**

Aiphone warrants its products to be free from defects in material and workmanship under normal use and service for a period of one year after delivery to the ultimate user. We will repair free of charge or replace at no charge Aiphone product, that upon examination by an Aiphone Repair Technician is proven defective and under warranty. Aiphone reserves the right to make the final decision whether there is a defect in materials and/or workmanship; and whether or not the product is within the warranty.

This warranty covers bench repairs by the Aiphone Service Department only, and does not extend to units that have been repaired or altered outside of the factory. Aiphone is not responsible for any costs incurred involving on-site service calls. This warranty shall not apply to any Aiphone product that has been subjected to misuse, neglect, accident, power surge, or used in violation of instructions furnished.

Aiphone Communication Systems  
1700 130th Ave. N.E.  
Bellevue, WA 98005  
(425) 455-0510  
FAX (425) 455-0071

**TOLL FREE TECHNICAL SUPPORT:**  
(800) 692-0200  
E-MAIL: tech@aiphone.com

Pg. 4  
IPW-1A Instr.  
0210Tech