

NexStar.2

EXTERNAL 5.25" HARD DRIVE ENCLOSURE



Model: NST-530U2

Specifications:

- Interface: IDE to USB 2.0
- Dimension: 251.5 x 172 x 49 mm
- Supports: Window 98 SE / ME / 2000 / XP
Mac OS 8.6 & Above

Package Includes:

- Driver Disc
- Power
- Cable
- USB Cable
- User Manual
- Screws

Platforms

Window 98SE / ME / 2000 / XP
Mac OS 8.6 & Above

System Requirements

Intel Pentium II 350 MHz-compatible or
Mac G3 processor & greater
Microsoft Windows 98SE/ME/2000/XP
or Mac OS 8.6 & greater
USB-equipped system
For USB 2.0 speeds, the system must
support USB 2.0 specifications
CD Rom drive (if drivers are needed)

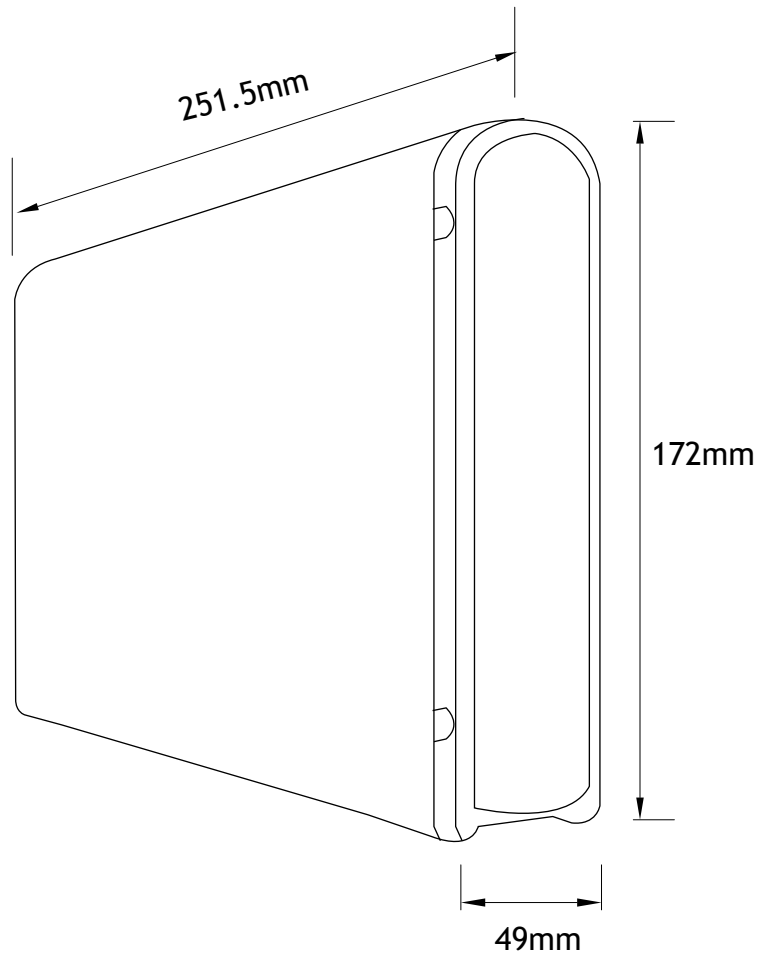

43951 Boscell Road
Fremont, CA 94538
Tel: 510-668-0368
Fax: 510-668-0367

www.vantecusa.com

Copyright © 2006 Vantec Thermal Technologies. All Rights Reserved.
All registered trademarks belong to their respective companies.