

Assembly instruction for 31401-38

- 1 connect fixture arm (B) with flush pan (C)
- 2 Install fixture loop (A) to fixture (B) for pendant only.
- 3 Use the lock up nut (D) to connet with fixture (B) and loop (A).
- 4 Adjust arms to space evenly .
- 5 Install light bulbs not provided
- 6 Secure glass (J) with center pipe(E),nipple(F),check ring(G),glass washer(H),nut(I),glass washer(K),nut(L) ,bottom cap(M) and finial (N)
- 7 Connect electrical wires at junction box and secure crossbar, nipple and canopy loop.



Assembly Instruction for the fixture with safety cable

NOTE: Fixtures weighing over 50 lbs, must be supported independently of the outlet bos

- 1) Turn off power.
- 2) Supply wires shall enter the outlet box through any knockout except the top center knockout.
- 3) Fixture is to be mounted by a steel pipe approximately 3/4" of 3/8-18NPSN threads at bottom. (Not Supplied) Position pipe so that approximately 1/2" of thread protrudes into outlet box. Attach pipe to a structural bridging member of sufficient strength to support at least 4 times the fixture weigh.
- 4) Thread pipe coupling onto protruding inside outlet box.
- 5) Thread hex nut onto threaded pipe. Screw threaded pipe into pipe coupling. Secure in place by tightening hex out against pipe coupling and tightening allen head screw.
- 6) Thread hexnut. Slip on ground wire and thread a second hex nut onto threaded pipe.
- 7) Connect screw collar loop (without threaded ring) to threaded pipe.
- 8) Pass canopy over screw collar loop. Approximately one-half of the screw collar loop exterior thread should be exposed. Adjust loop as required. Remove canopy and tighten hex nut against screw collar loop. Tighten second hex nut against first to hold ground wire in place.
- 9) Attach chain to fixture (not shown)
- 10) Slip threaded ring then canopy onto chain
- 11) Attach chain (with fixture connected) to bottom of screw collar loop.
- 12) Weave silver support cable up chain and exit through top hole in side of pipe coupling. Slip cable through top existing opening or drill 3/16" dia. Hole near center of outlet box. Wrap cable around structural member described in step #3. Cable must be pulled taut to evenly distribute fixture weight between cable and chain. Secure cable with (2) clamps provided.
- 13) Weave both fixture wires and copper ground wire up chain and exit through top hole inside of pipe coupling.
- 14) Connect fixture ground wire and ground wire attached to threaded pipe to outlet box ground wire with wire connector (not provided). Never connect ground wire to black or power supply wires. Make wire connections (connectors not provided) Reference chart below for correct connections and wire accordingly.

Connect Black or Red Supply Wire to:	Connect Black or White Supply Wire to :
Black	White
*Parallel cord (round & smooth)	*Parallel cord (square & ridged)
Clear, Brown, Gold or Black without tracer	Clear, Brown, Gold or Black without tracer
Insulated wire (other than green) with copper conductor	Insulated wire (other than green) with silver conductor

Notes: When parallel (SPTI & SPTIII) are used. The Neutral wire is square shaped or ridged and the other wire will be round in shape or smooth (see us)

Warning:
Consult a qualifie
Electrician for
installation

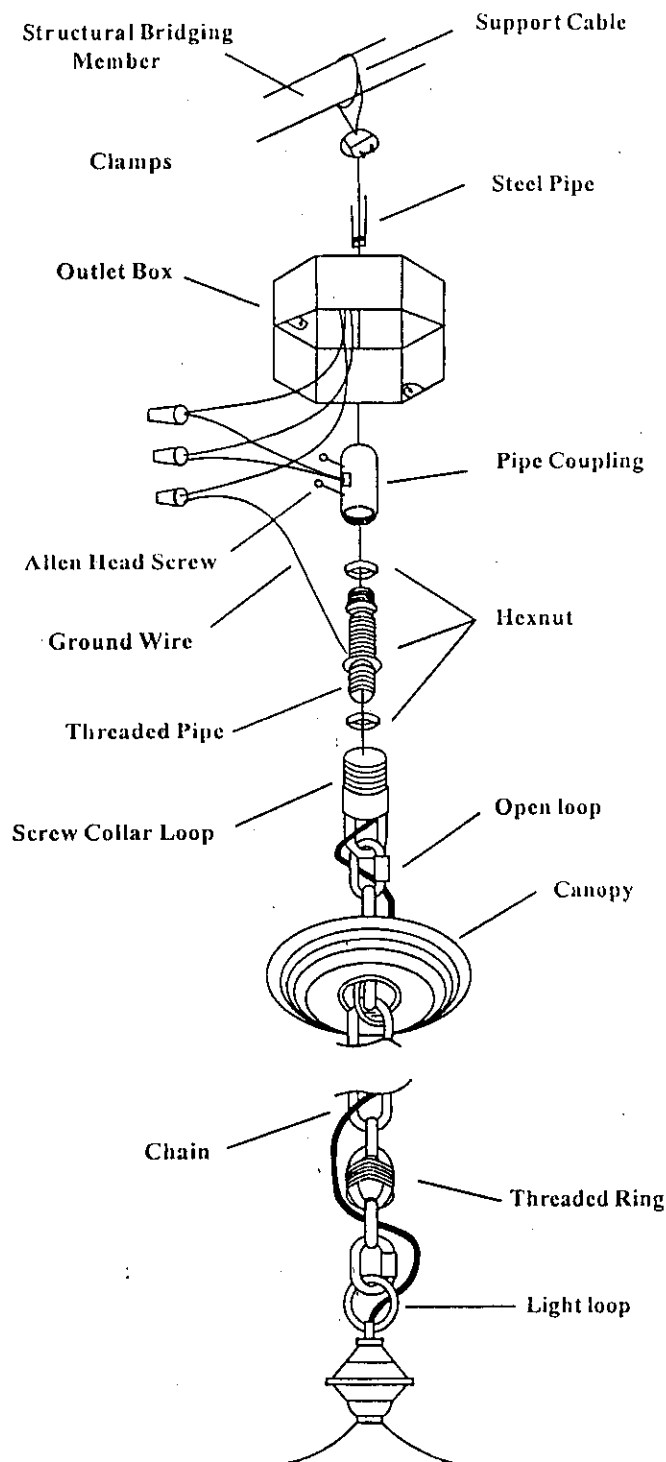

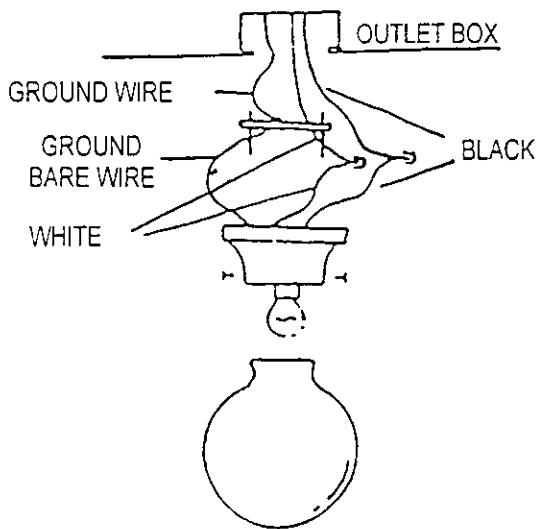
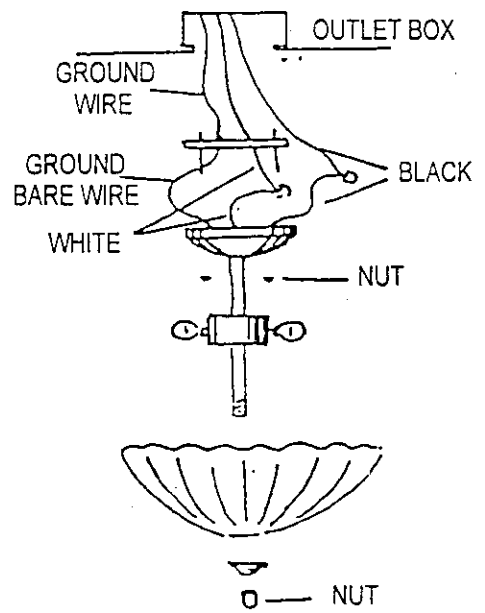
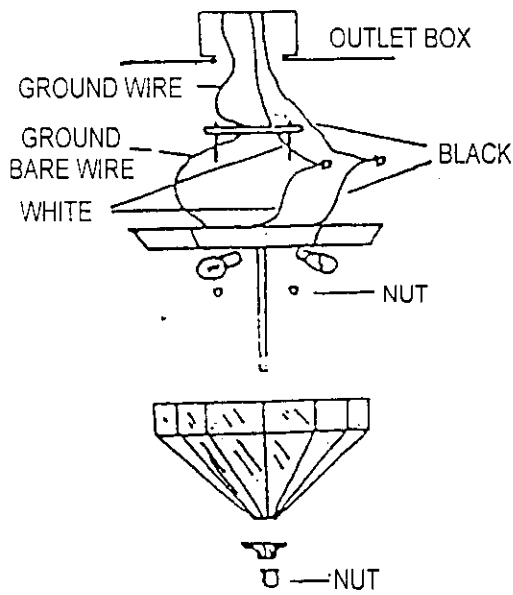
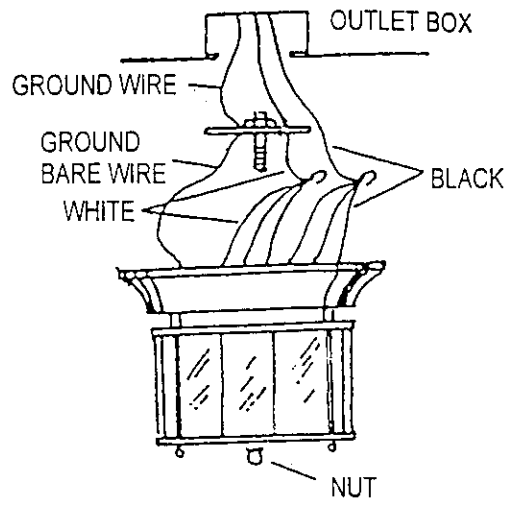
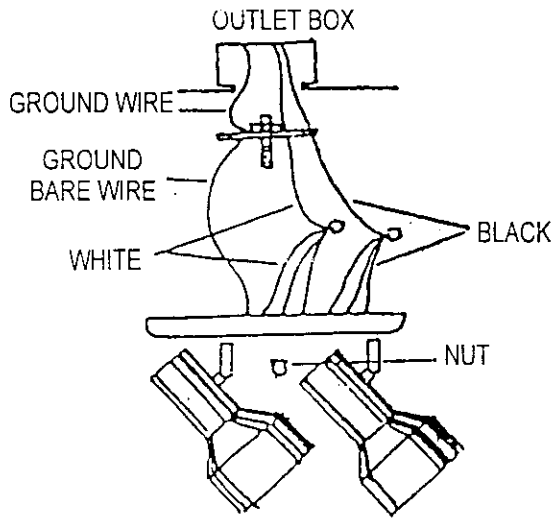

READ AND SAVE THESE INSTRUCTIONS
INSTALLATION OPERATION INSTRUCTIONS

CAUTION: Before assembling your Lighting fixture, refer to the section titled **ELECTRICAL CONNECTIONS**. If you feel you do not have electrical wiring experience, refer to a do-it-yourself Wiring handbook or have your fixture installed by a qualified Licensed electrician.

GENERAL

1. To ensure the success of the installation, be sure to read these instructions and review the diagrams thoroughly before beginning.
2. All electrical connections must be in accordance with local codes, ordinances, or the National Electrical code. If you are unfamiliar with methods of installing electrical wiring, secure the services of a licensed electrician.
3. These fixtures are intended to be mounted to a 4" x2-1/8" deep metal octagon box. The box must be directly supported by the building structure.
4. Before starting the installation, disconnect the power by turning off the circuit breaker of by removing the fuse at the fuse box. Turning the power off using the light switch is not sufficient to prevent electrical shock.

NOTE: The important safeguards and instructions appearing in this manual are not meant to cover or all possible conditions and situations that may occur. It must be understood that common sense, caution, and care are factors which cannot be built into any product. These factors must be supplied by the person(s) caring for, installing and operating the fixture.

PREPARE THE FIXTURE

NOTE: FIRST TURN OFF THE ELECTRICITY

1. If you are replacing an existing fixture, disconnect and remove the old fixture. Expose supply wiring to an outlet box.
2. Turn the machine screws into the opposite side of the cross-bar so that screws are facing the downward direction as illus - trated in Figure 1.
3. Fasten the crossbar to the outlet box using the two screws supplied with the outlet box.
4. Connect the grounding wire (green or bare copper) from the supply circuit to grounding wire of the fixture (green or bare copper) and attach the wires to the green grounding attachment screw provided on the crossbar.
5. Make Electrical connections

ELECTRICAL CONNECTIONS AS ILLUSTRATED IN FIGURE 1.

WARNING — Risk of fire. Most dwellings built before 1985 have supply wire rated 60°C, consult a qualified electrician before installing.

connect the white wire (s) (or the ribbed wires) from the fixture to the white wire of the supply circuit. connect the black wire(s) (of the smooth side of wires) from the fixture to the black wire of the supply circuit. Connect the green (of bare copper) colored wire to the grounding conductor of the supply circuit.

If your fixture is supplied with an spl cord (same color each side), connect the half of the spl cord that is ribbed surface to the wire of the supply circuit. connect the smooth half of the wire (the half with markings) to the black wire of the supply circuit. Use UL Listed wire connectors suitable for the size, type and number of conductors. No loose strands or loose wires should be present. secure wire connectors with UL Listed electrical tape.

FINAL ASSEMBLY

1. spread the electrical splices so that the black wires are on one side of the outlet box and the white wires are on the other side.
2. place the fixture against the mounting surface allowing the machine screws to pass through the fixture. secure with acorn nut provided.
3. Install Light Bulbs — Do not exceed recommended wattage.
4. Restore electricity and check the operation of your new lighting fixture.