

**READ AND UNDERSTAND THESE INSTRUCTIONS BEFORE INSTALLING FIXTURE**

This fixture is intended for installation in accordance with the National Electrical Code and local regulations. To assure full compliance with local codes and regulations, check with your local electrical inspector before installation. To prevent electrical shock, turn off electricity at fuse box before proceeding.

Retain these instructions for maintenance reference.

INSTRUCTION SHEET NO.

**IS:40719**

0393 Page 1 of 1

**INSTRUCTIONS FOR INSTALLATION AND ASSEMBLY OF  
RADIANCE STEM EXTENSION KITS**

**CAUTION: BE CAREFUL WHILE HANDLING FIXTURE WIRES. DO NOT DAMAGE WIRE INSULATION OR PINCH WIRES BETWEEN PARTS.**

1. Unpack CENTER STEM ASSEMBLY (supplied with fixture) and carefully un-coil FIXTURE WIRES.
2. Gently pull downward on CANOPY to disengage from CROSSBAR SPRING CLIPS and expose CROSSBAR (Fig. 1).
3. Remove the two SCREWS from both sides of SWIVEL CASTING and slide SWIVEL PIN out from one of the holes in the SWIVEL CASTING (Fig. 1).  
NOTE: A small screwdriver may be required to push SWIVEL PIN out through the hole in SWIVEL CASTING.

**CAUTION: PLACE SCREWS AND SWIVEL PIN IN A SAFE PLACE; THESE PARTS ARE NEEDED FOR FINAL ASSEMBLY OF EXTENSION KIT.**

4. While holding CENTER STEM ASSEMBLY and FIXTURE WIRES, gently slide SWIVEL CASTING/CROSSBAR ASSEMBLY up FIXTURE WIRES until ASSEMBLY is completely removed from FIXTURE WIRES (Fig. 2). Place SWIVEL CASTING/CROSSBAR ASSEMBLY in a safe place.  
NOTE: Make certain QUICK CONNECTORS at the lower end of CENTER STEM ASSEMBLY do not slide up inside STEM.

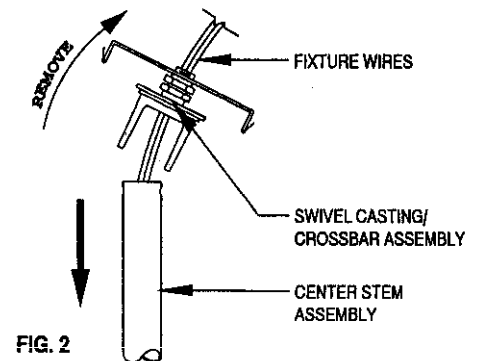
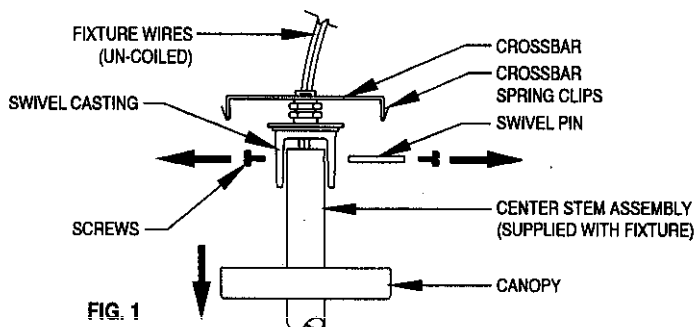

5. Pass FIXTURE WIRES through EXTENSION STEM COLLAR and EXTENSION STEM and slide EXTENSION STEM down FIXTURE WIRES until EXTENSION STEM COLLAR meets CENTER STEM ASSEMBLY (Fig. 3A).
6. Aligning the holes in the side of CENTER STEM ASSEMBLY with the threaded holes in EXTENSION STEM COLLAR, allow COLLAR to slide inside CENTER STEM ASSEMBLY and secure in place by installing the two screws provided with EXTENSION STEM KIT (Fig. 3B).  
NOTE: Before proceeding; repeat steps 5 and 6 if a second EXTENSION STEM KIT is to be used.
7. Re-assemble SWIVEL CASTING/CROSSBAR ASSEMBLY to the end of EXTENSION STEM by reversing steps 3 and 4 above (Fig. 4).
8. Continue FIXTURE installation by following instructions supplied with FIXTURE.  
NOTE: FIXTURES are supplied with enough FIXTURE WIRE to allow two EXTENSION STEM KITS to be installed. If only one EXTENSION KIT is used; excess FIXTURE WIRES should be cut off making certain there is a minimum of 6" of FIXTURE WIRE above CROSSBAR ASSEMBLY for OUTLET BOX WIRING.

