

INSTALLATION INSTRUCTIONS

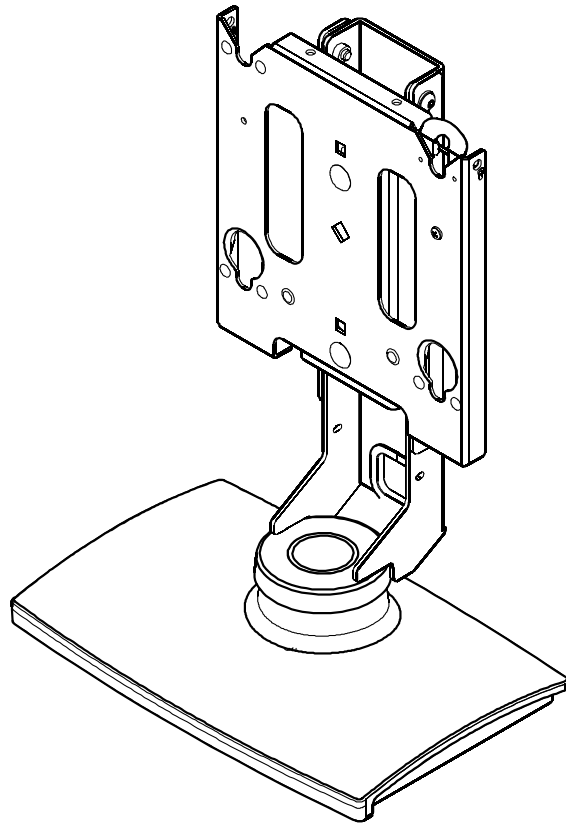

LCD Swivel Stand

DISCLAIMER

Milestone AV Technologies, Inc., and its affiliated corporations and subsidiaries (collectively, "Milestone"), intend to make this manual accurate and complete. However, Milestone makes no claim that the information contained herein covers all details, conditions or variations, nor does it provide for every possible contingency in connection with the installation or use of this product. The information contained in this document is subject to change without notice or obligation of any kind. Milestone makes no representation of warranty, expressed or implied, regarding the information contained herein. Milestone assumes no responsibility for accuracy, completeness or sufficiency of the information contained in this document.



WARNING: Failure to read, thoroughly understand, and follow all instructions can result in serious personal injury, damage to equipment, or voiding of factory warranty! It is the installer's responsibility to make sure all components are properly assembled and installed using the instructions provided.



WARNING: Failure to provide adequate structural strength for this component can result in serious personal injury or damage to equipment! It is the installer's responsibility to make sure the structure to which this component is attached can support five times the combined weight of all equipment. Reinforce the structure as required before installing the component.



WARNING: Exceeding the weight capacity can result in serious personal injury or damage to equipment! It is the installer's responsibility to make sure the combined weight of all components located on the MSS (including the display) does not exceed 150 lbs (68.04 kg).

IMPORTANT WARNINGS AND CAUTIONS!



WARNING: A WARNING alerts you to the possibility of serious injury or death if you do not follow the instructions.



CAUTION: A CAUTION alerts you to the possibility of damage or destruction of equipment if you do not follow the corresponding instructions.

DIMENSIONS

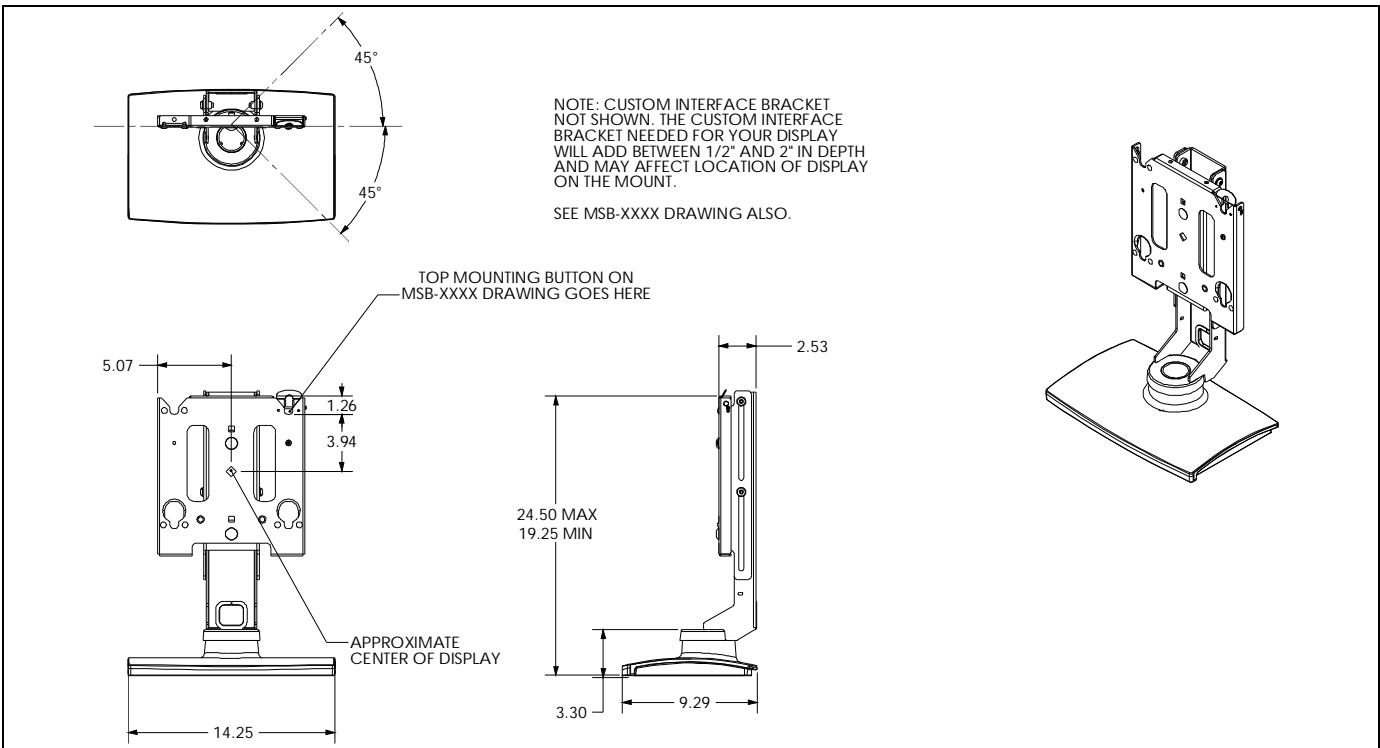

LEGEND

	Tighten Fastener
	Apretar elemento de fijación
	Befestigungsteil festziehen
	Apertar fixador
	Serrare il fissaggio
	Bevestiging vastdraaien
Serrez les fixations	

	Loosen Fastener
	Aflojar elemento de fijación
	Befestigungsteil lösen
	Desapertar fixador
	Allentare il fissaggio
	Bevestiging losdraaien
Desserrez les fixations	

	Phillips Screwdriver
	Destornillador Phillips
	Kreuzschlitzschraubendreher
	Chave de fendas Phillips
	Cacciavite a stella
	Kruiskopschroevendraaier
Tournevis à pointe cruciforme	

	Open-Ended Wrench
	Llave de boca
	Gabelschlüssel
	Chave de bocas
	Chiave a punte aperte
	Steeksleutel
Clé à fourche	

	By Hand
	A mano
	Von Hand
	Com a mão
	A mano
	Met de hand
À la main	

	Hex-Head Wrench
	Llave de cabeza hexagonal
	Sechskantschlüssel
	Chave de cabeça sextavada
	Chiave esagonale
	Zeskantsleutel
Clé à tête hexagonale	

	Pencil Mark
	Marcar con lápiz
	Stiftmarkierung
	Marcar com lápis
	Segno a matita
	Potloodmerkteken
Marquage au crayon	

	Drill Hole
	Perforar
	Bohrloch
	Fazer furo
	Praticare un foro
	Gat boren
Percez un trou	

	Adjust
	Ajustar
	Einstellen
	Ajustar
	Regolare
	Afstellen
Ajuster	

	Remove
	Quitar
	Entfernen
	Remover
	Rimuovere
	Verwijderen
Retirez	

	Optional
	Opcional
	Optional
	Opcional
	Opzionale
	Optie
En option	

	Security Wrench
	Llave de seguridad
	Sicherheitsschlüssel
	Chave de segurança
	Chiave di sicurezza
	Veiligheidssleutel
Clé de sécurité	

TOOLS REQUIRED FOR INSTALLATION

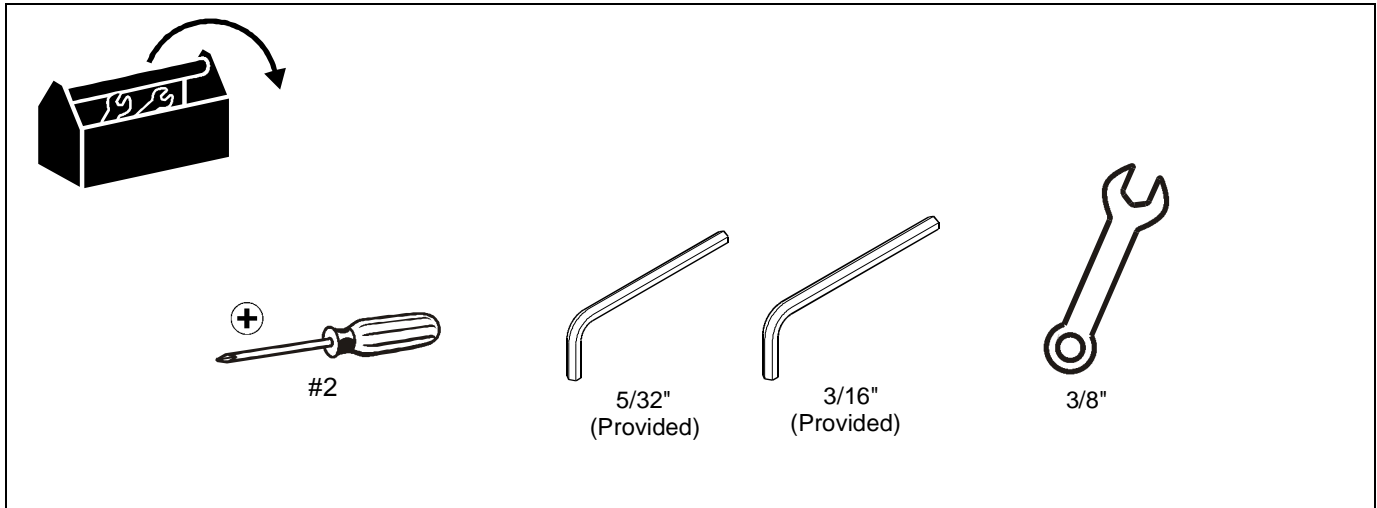

PARTS

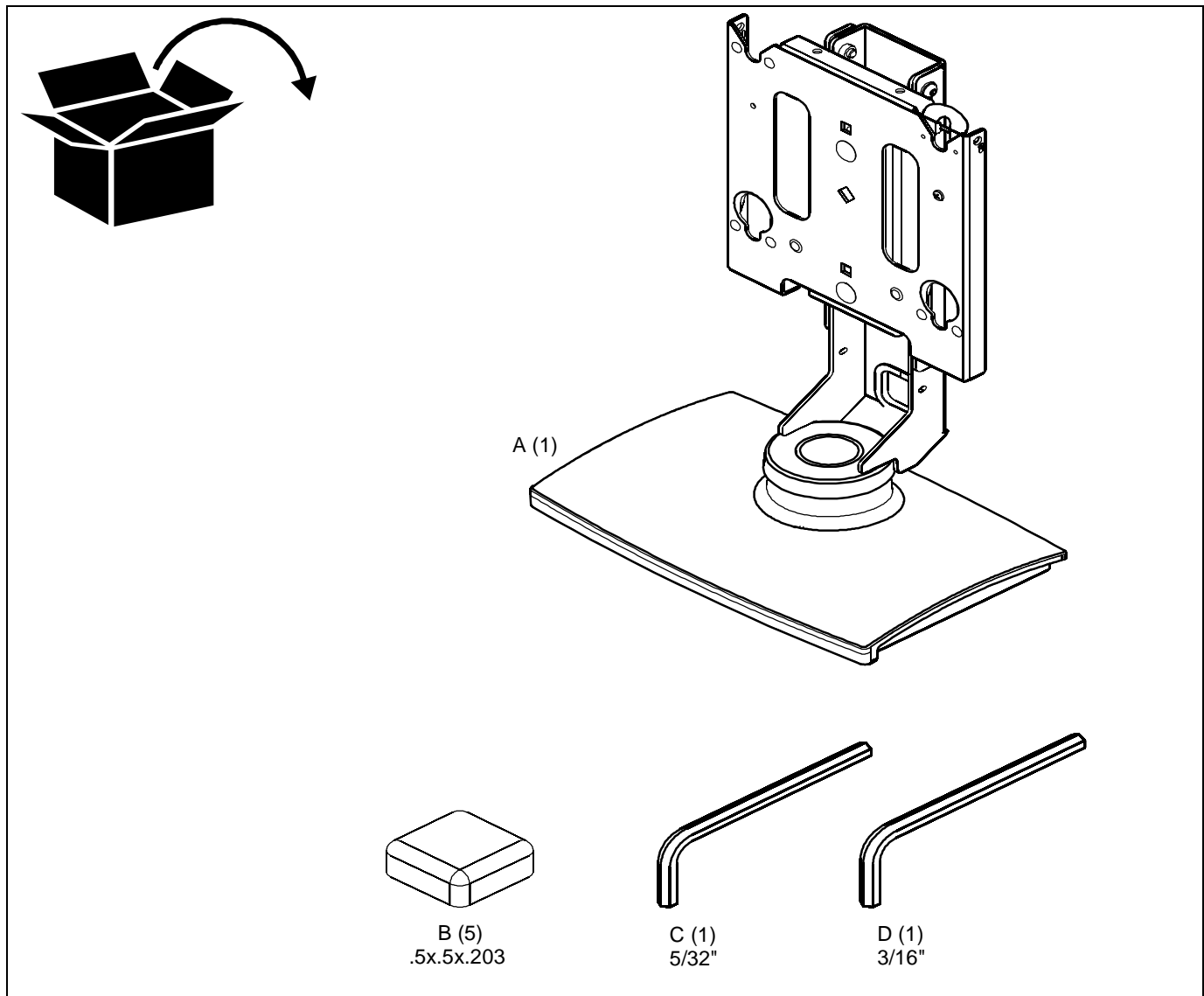

INSTALLATION

Mount Installation

Free Standing (not anchored) Applications Only:

NOTE: Do not perform this step if you are going to anchor the stand to a surface.

1. Install five rubber bumpers (B) on bottom of stand. (See Figure 1)

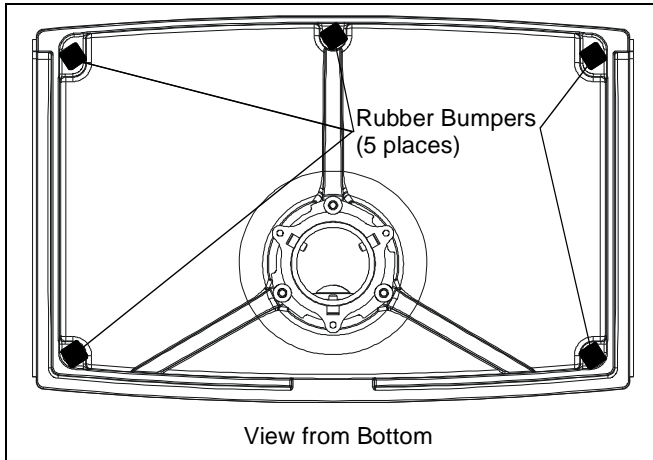

Figure 1

Display 24 Inches High or Smaller:

1. Loosen the four height adjustment screws and raise the slide to its maximum height. (See Figure 2)
2. Secure the slide by tightening the four height adjustment screws.

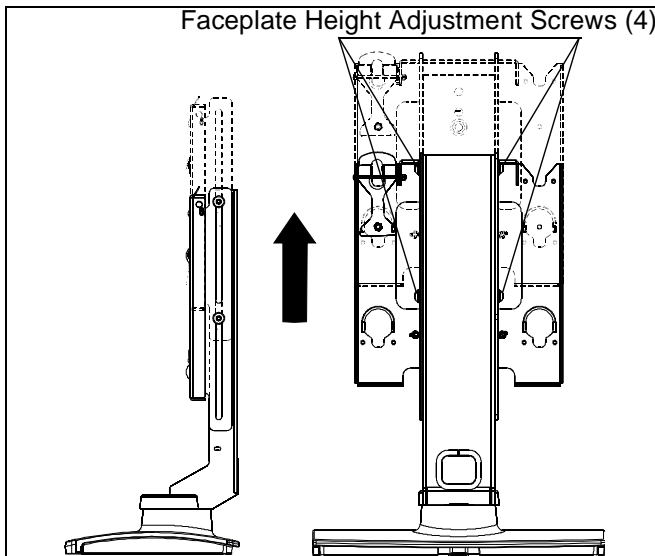

Figure 2

Display More Than 24 Inches High:

NOTE: The MSS-6000 comes pre-configured for displays 24" in height or less. If a display with a height greater than 24" is being installed follow the instructions below.

To install a display with a height greater than 24":

1. Remove slide plate assembly from the base by removing four 5/16-18 x 3/4" button head cap screws, and four 1/4" flat washers. (See Figure 3)

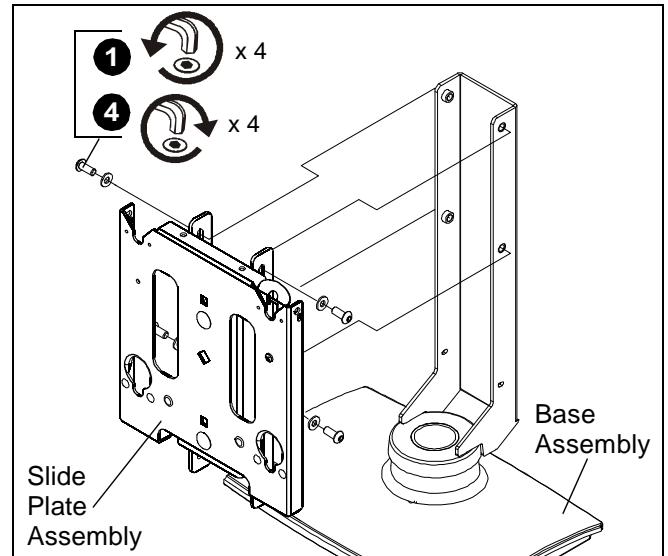

Figure 3

2. Remove face plate from slide plate assembly by removing two 3/8"-16 x 1" round head carriage bolts, two 1" OD x .563 ID spacers, two 3/8" flat washers, and two 3/8-16 lock nuts. (See Figure 5)
3. Reinstall face plate into upper mounting holes of slide plate using two 3/8"-16 x 1" round head carriage bolts, two 1" OD x .563 ID spacers, two 3/8" flat washers, and two 3/8-16 lock nuts removed in Step 2. (See Figure 5)
4. Reinstall slide plate assembly onto base using four 5/16-18 x 3/4" button head cap screws and four 1/4" flat washers previously removed in Step 1. (See Figure 3)
5. Raise slide plate assembly to maximum height.
6. Secure slide plate in place by tightening the four height adjustment screws. (See Figure 2)

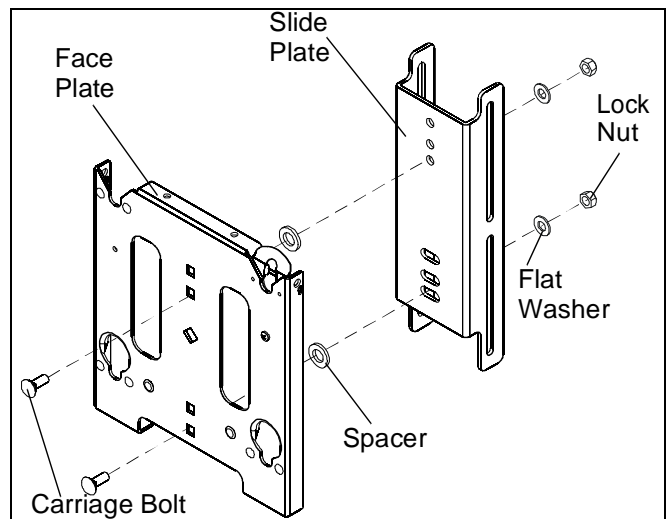

Figure 4

Display Installation

The following procedure assumes that the proper interface bracket for the display being mounted has already been installed on the display.

If no interface bracket is present on display, install bracket to display using the instructions included with the interface bracket before proceeding.

If an interface bracket for the display being mounted needs to be obtained, or additional assistance is required, contact a Chief Customer Service representative by calling 1-800-582-6480 or by visiting www.chiefmfg.com.

NOTE: If the display being mounted has a height of more than 24" the mount needs to be modified prior to display installation.

(See **Display More Than 24 Inches High** on page 5)

To install the display:

1. While supporting both sides of display, align four mounting buttons on display or interface bracket with four mounting holes in faceplate. (See Figures 5 and 6)

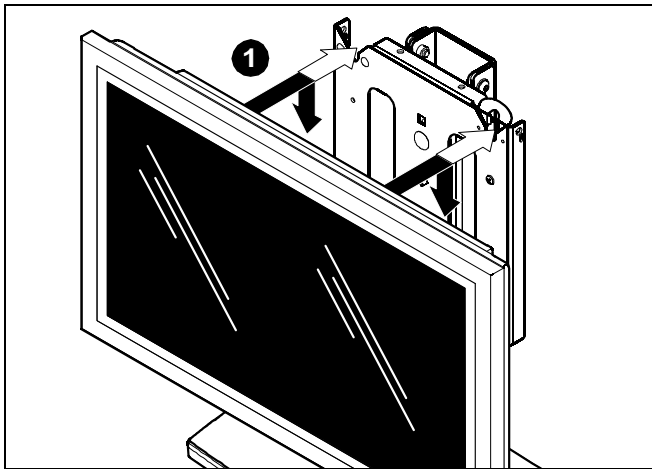

Figure 5

2. Lower display into place listening for audible "click" to ensure recessed area of mounting buttons are properly seated in lower area of mounting holes. (See Figures 5 & 6)



WARNING: IMPROPER INSTALLATION CAN LEAD TO DISPLAY FALLING CAUSING SERIOUS PERSONAL INJURY OR DAMAGE TO EQUIPMENT! Ensure mounting buttons are completely engaged in mounting holes.

NOTE: Holes are provided in the faceplate for use with a padlock or similar locking device, if desired. In addition, the pin and nut may be removed from the upper holes and moved to the lower holes for use as a more permanent locking device. (See Figure 6).

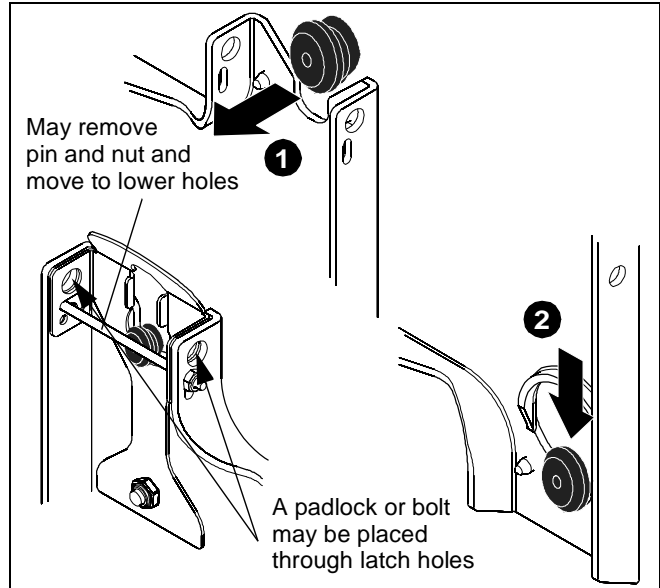

Figure 6

Removing Display from Mount

1. Remove bolt or padlock from faceplate (if used). (See Figure 7)

NOTE: The pin may have been used as a more permanent locking device. If so, remove nut and pin and move from the lower holes to the upper holes.

2. Pull back on flag on upper mounting hole and press pin down into "Open" position. (See Figure 7)
3. Carefully lift display from mount.
4. Lift up on pin and place flag back against faceplate to return it to "Closed" position. (See Figure 7)

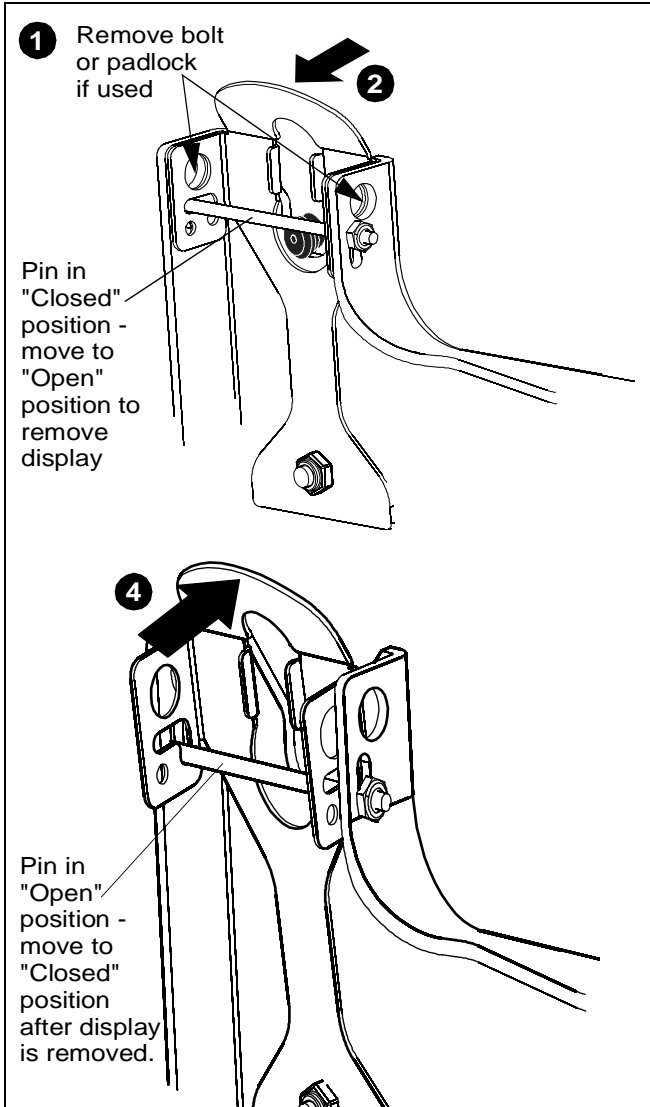

Figure 7

ADJUSTMENTS

Display Height Adjustment



CAUTION: Displays are fragile. Allowing the display to drop to bottom of stand may result in damage to the display.

1. While holding the display, loosen the four height adjustment screws. (See Figure 8)



CAUTION: Make sure all cables and wires are not pinched when raising or lowering display.

2. Position display at the desired height.
3. Tighten four height adjustment screws. (See Figure 8)

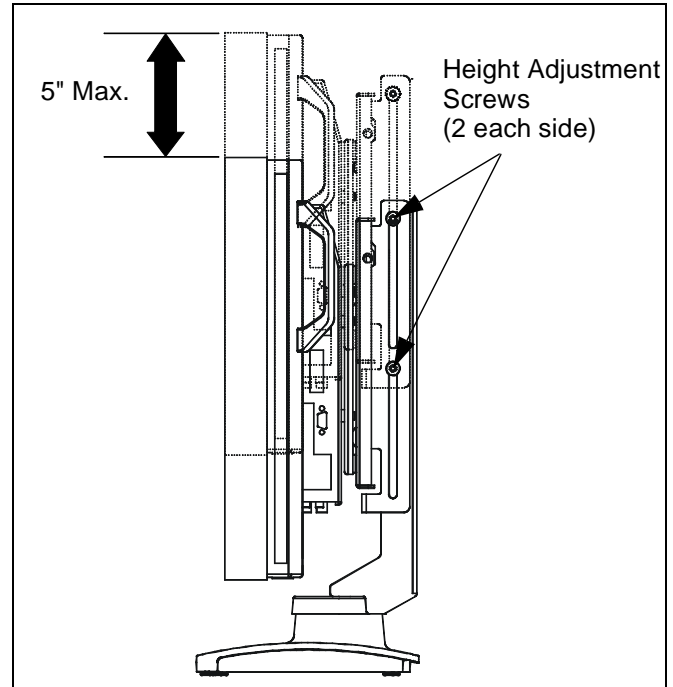

Figure 8

Display Roll Adjustment

The MSS-6000 provides limited display roll adjustment for the purpose of leveling the display.

To level the display:

1. Loosen upper and lower roll adjustment nuts. (See Figure 9)
2. Level display. (See Figure 9)
3. Tighten roll adjustment nuts.

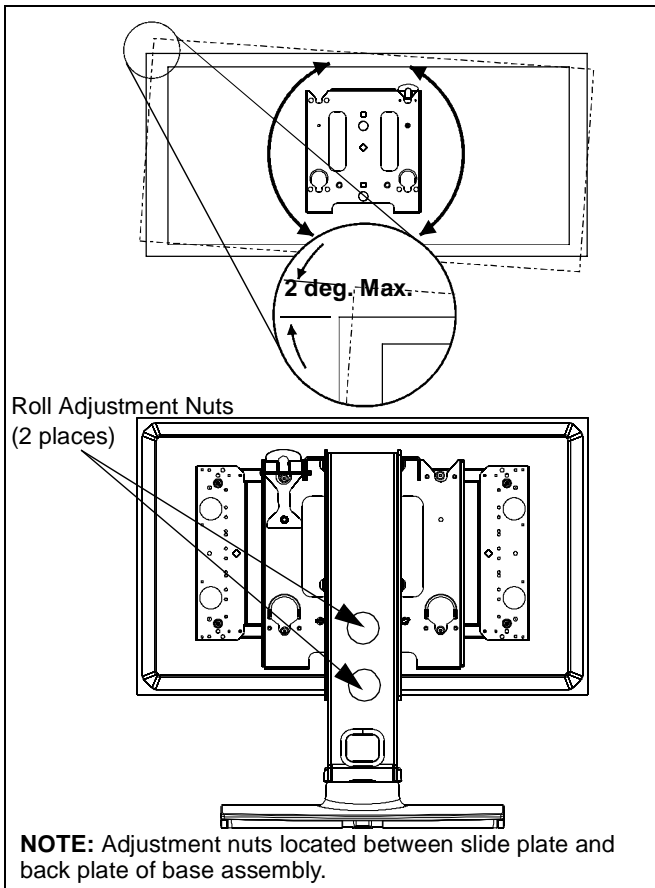

Figure 9

Display Swivel Tension Adjustment

Display swivel tension is pre-set at the factory. Swivel tension will vary depending on the weight of display being mounted.

If swivel tension adjustment is required:

1. Disconnect all cords and cables from display.
2. Follow steps in **Removing Display from Mount** section.
3. Lay mount on back. (See Figure 10)
4. Locate three tensions adjustment screws. (See Figure 10)
5. Turn each adjustment screw either clockwise to increase tension, or counter-clockwise to decrease tension.

NOTE: It is important that all adjustment screws are turned equal amounts in the same direction for the display to turn properly.

6. Install display following the instruction outlined in **Display Installation** section on page 6.
7. Test display swivel tension by grasping each side of display and turning display left and right.

If additional swivel tension adjustment is required, repeat

steps 1 through 7 above.

Display Swivel Stop Location Adjustment

The MSS-6000 allows for the installation of swivel stops that limit the amount of display travel. Stops can be installed at +/-15, 25 or 35 degrees.

To install swivel stops:

1. Follow steps 1 through 3 of **Display Swivel Tension Adjustment** section.
2. Insert one 10-24 X 1/2" Phillips head cap screw in one of the three swivel stop holes (15, 25 or 35 degrees) in the base of the stand. (See Figure 11)

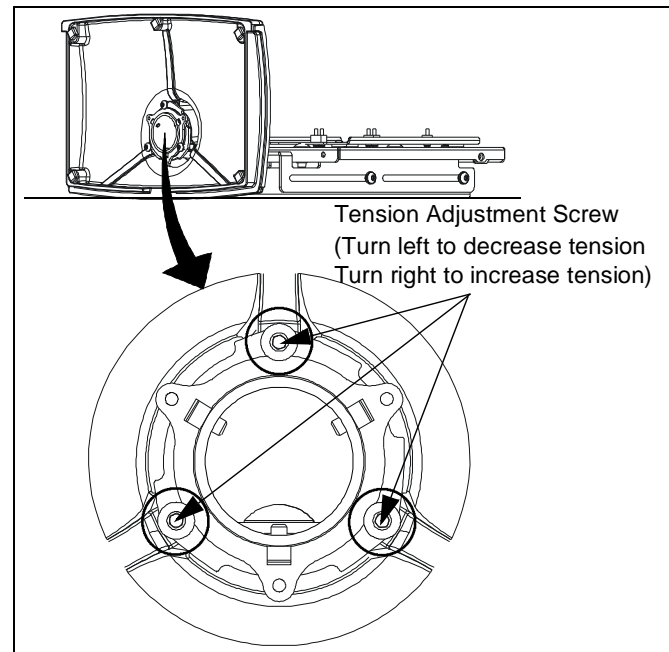

Figure 10

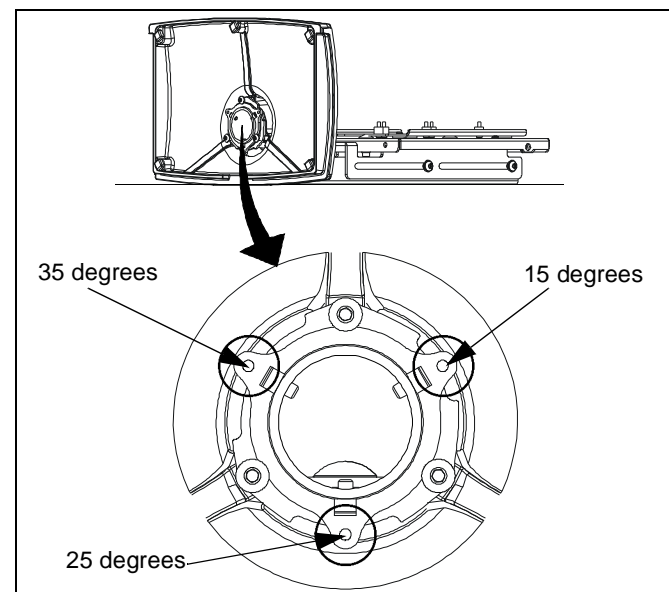

Figure 11

Cable Management

The MSS-6000 has been designed to provide multiple cable management/routing options.

Option A

Option A does not use the cable access features of the MSS-6000 and simply routes the cables away from the display and mount. (See Figure 12)

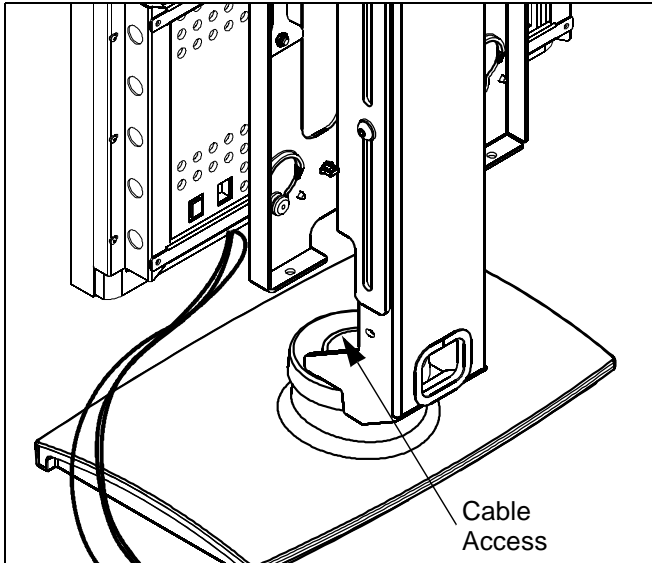

Figure 12

Option B

Option B uses the cable access at the center of the MSS-6000 and then routes the cables across the mounting surface and out the rear cable access slot in the back of the mount. (See Figure 13)

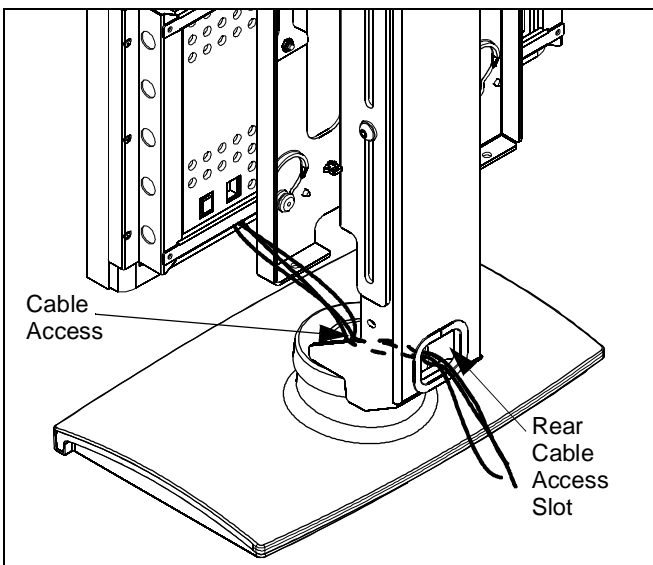

Figure 13

Option C

Option C uses the cable access at the center of the MSS-6000 and then routes the cables down through an access hole or slot in the mounting surface. (See Figure 14)

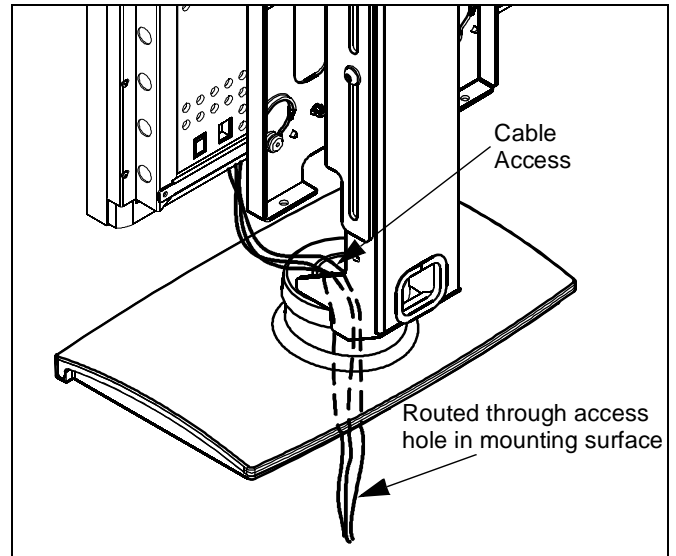

Figure 14



8800-000057 Rev. B
©2008 Chief Manufacturing
www.chiefmfg.com
03/08

USA/International	A 8401 Eagle Creek Parkway, Savage, MN 55378 P 800.582.6480 / 952.894.6280 F 877.894.6918 / 952.894.6918
Europe	A Fellenoord 130 5611 ZB EINDHOVEN, The Netherlands P +31 (0)40 2668620 F +31 (0)40 2668615
Asia Pacific	A Room 24F, Block D, Lily YinDu International Building LuoGang, BuJi Town, Shenzhen, CHINA. 深圳市布吉罗岗村百合银都国际大厦D栋24F P +86-755-8996 9226 F +86-755-8996 9217