

BUNN®

1SH & 2SH STAND

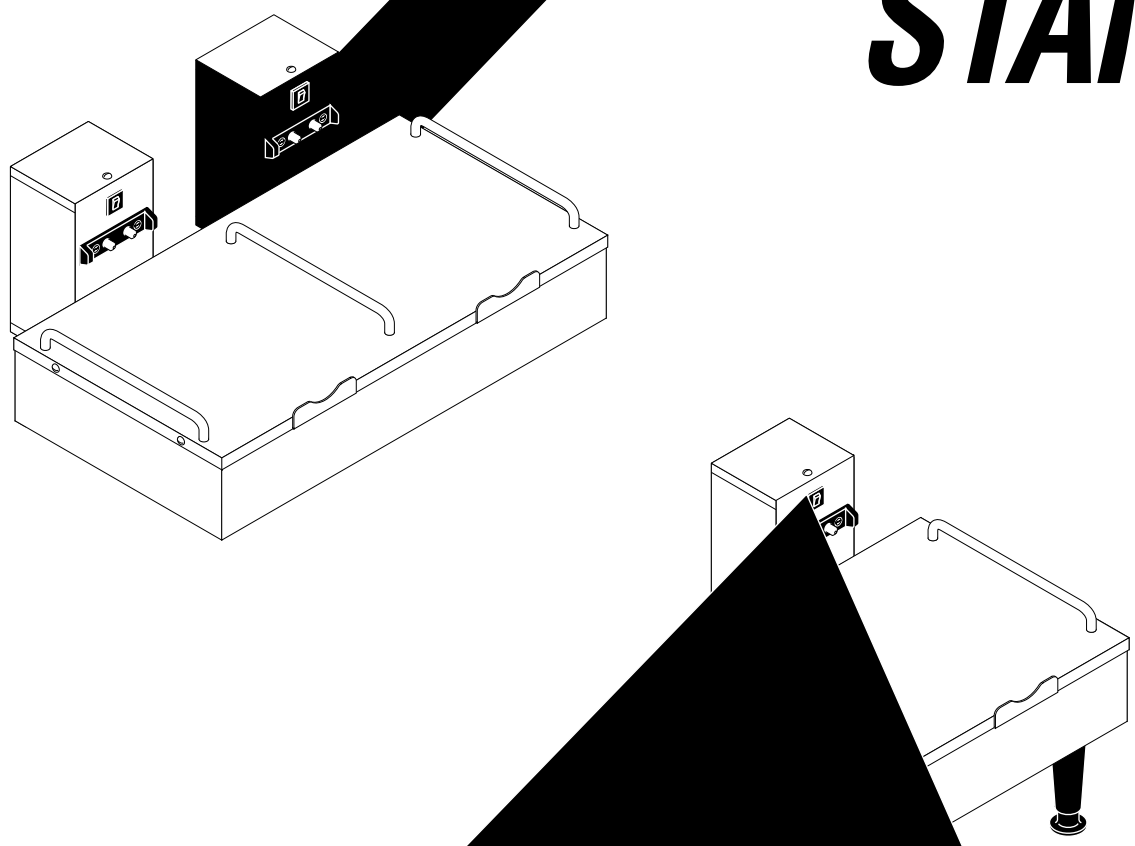

OPERATION & MAINTENANCE MANUAL

BUNN-O-MATIC CORPORATION
POST OFFICE BOX 3227
SPRINGFIELD, ILLINOIS 62708-3227
PHONE: (217) 529-6601 FAX: (217) 529-6644

WARRANTY

Bunn-O-Matic Corp. ("Bunn") warrants the equipment manufactured by it to be commercially free from defects in material and workmanship existing at the time of manufacture and appearing within one year from the date of installation. In addition:

1.) Bunn warrants electronic circuit and/or control boards to be commercially free from defects in material and workmanship for two years from the date of installation.

2.) Bunn warrants the compressor on refrigeration equipment to be commercially free from defects in material and workmanship for two years from the date of installation.

3.) Bunn warrants that the grinding burrs on coffee grinding equipment will grind coffee to meet original factory screen sieve analysis for three years from date of installation or for 30,000 pounds of coffee, whichever comes first.

This warranty does not apply to any equipment, component or part that was not manufactured by Bunn or that, in Bunn's judgement, has been affected by misuse, neglect, alteration, improper installation or operation, improper maintenance or repair, damage or casualty.

THE FOREGOING WARRANTY IS EXCLUSIVE AND IS IN LIEU OF ANY OTHER WARRANTY, WRITTEN OR ORAL, EXPRESS OR IMPLIED, INCLUDING, BUT NOT LIMITED TO, ANY IMPLIED WARRANTY OF EITHER MERCHANTABILITY OR FITNESS FOR A PARTICULAR PURPOSE. The agents, dealers or employees of Bunn are not authorized to make modifications to this warranty or to make additional warranties that are binding on Bunn.

USER NOTICES

The notice on the stands should be kept in good condition. Replace if unreadable or damaged.

00986.0000

⚠ WARNING
<ul style="list-style-type: none">• DO NOT OVERLOAD CIRCUIT.• ALWAYS ELECTRICALLY GROUND THE CHASSIS OR ADAPTOR PLUG.• DO NOT DEFORM PLUG OR CORD.• FOLLOW NATIONAL AND LOCAL ELECTRICAL CODES.• KEEP COMBUSTIBLES AWAY.
FAILURE TO COMPLY RISKS EQUIPMENT DAMAGE, FIRE OR SHOCK HAZARD.
READ THE ENTIRE OPERATING MANUAL BEFORE USING THIS PRODUCT
<small>00986.0000E 5/98 © 1994 Bunn-O-Matic Corporation</small>

ELECTRICAL REQUIREMENTS

The stands have an attached cordset and requires 2-wire grounded service rated 120 volts ac, single phase, 90 watts total for the 1SH, 180 watts total for the 2SH, or 2-wire grounded service rated 230 volts ac, single phase, 90 watts total for the 1SH, 180 watts total for the 2SH.

CLEANING

The use of a damp cloth rinsed in any mild, nonabrasive, liquid detergent is recommended for cleaning all surfaces on Bunn-O-Matic equipment.

TROUBLESHOOTING

A troubleshooting guide is provided to suggest probable causes and remedies for the most likely problems encountered. If the problem remains after exhausting the troubleshooting steps, contact the Bunn-O-Matic Technical Service Department.

- Inspection, testing, and repair of electrical equipment should be performed only by qualified service personnel.
- All electronic components have 120 - 240 volt ac and low voltage dc potential on their terminals. Shorting of terminals or the application of external voltages may result in board failure.
- Intermittent operation of electronic circuit boards is unlikely. Board failure will normally be permanent. If an intermittent condition is encountered, the cause will likely be a contact or a loose connection at a terminal or crimp.

WARNING

- Exercise extreme caution when servicing electrical equipment.
- Disconnect power source when servicing, except when electrical tests are specified.
- Follow recommended service procedures.
- Replace all protective shields or safety notices.

Problem	Probable Cause	Remedy
Server will not heat	1. No power or incorrect voltage.	Be sure the stand is connected to the power source.
	2. Circuit breaker	A) Check and reset if necessary B) Refer to <i>Service</i> - Circuit breaker for test procedures. See page 4
	3. Receptacle contact	Clean or replace. See page 5
	4. Transformer	Refer to <i>Service</i> - Transformer for test procedures. See page 7
	5. Rectifier	Refer to <i>Service</i> - Rectifier for test procedures. See page 6



SERVICE (cont.)

Test Procedures

1. Disconnect the stand from the power source.
2. Remove the wires from the circuit breaker.
3. Check for continuity between the circuit breaker terminals. Continuity must be present between the terminals.

If continuity is present as described the circuit breaker is functioning properly.

If continuity is not present as described, press reset button and repeat step #3, if continuity is not present as described, replace the circuit breaker.

Removal and Replacement:

1. Remove the wires from the circuit breaker.
2. Compress the clips on the back side of the receptacle bracket and gently push the circuit breaker through the opening in the receptacle bracket.
3. Push the new circuit breaker into the opening in the receptacle bracket until the clips snap into position.
4. Reconnect the wires to the circuit breaker.
5. Refer to Fig. 3 when reconnecting the wires.

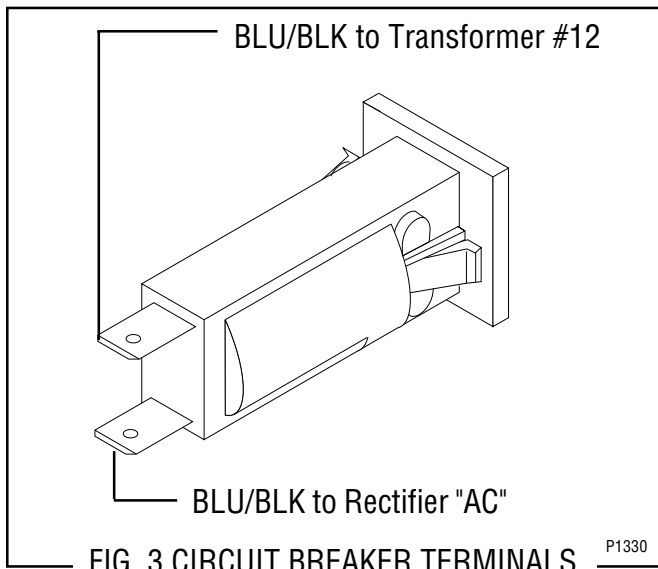

RECEPTACLE ASSEMBLY (SPRING CONTACT)

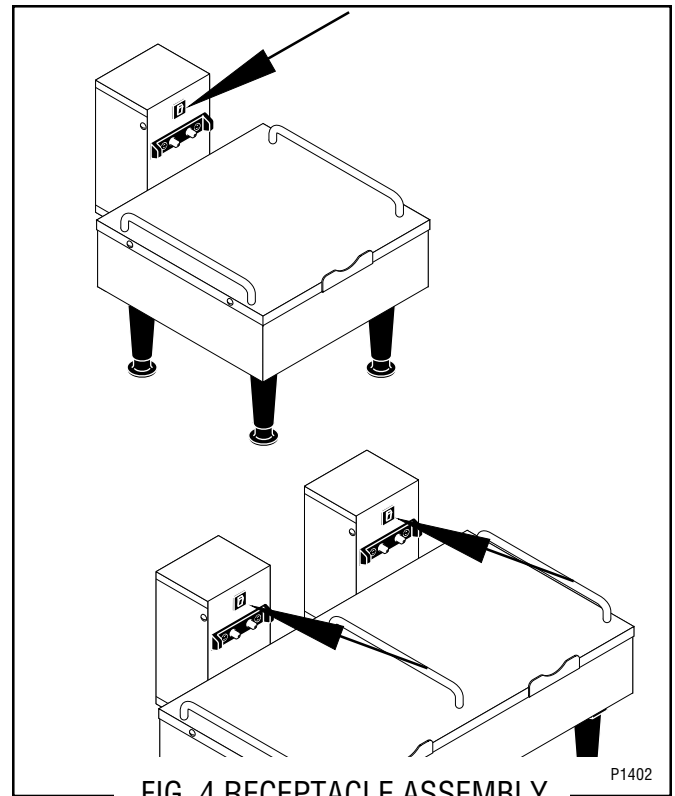

Location:

The receptacle assembly is located on the lower front of the receptacle bracket just below the circuit breaker.

Test Procedures:

1. Clean or replace spring contacts.

Removal and Replacement:

1. Disconnect the stand from the power source.
2. Disconnect the wires from the receptacle assembly.
3. Remove the two #6-32 flat head screws securing the receptacle to the receptacle bracket.
4. Remove and discard receptacle.
5. Install new receptacle in the receptacle bracket and secure with two #6-32 flat head screws..
6. Refer to Fig. 5 and reconnect the wires.

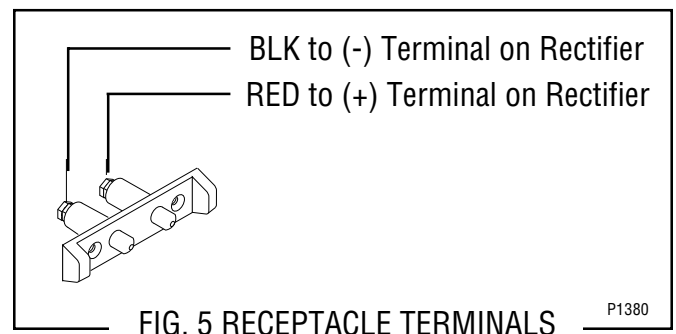

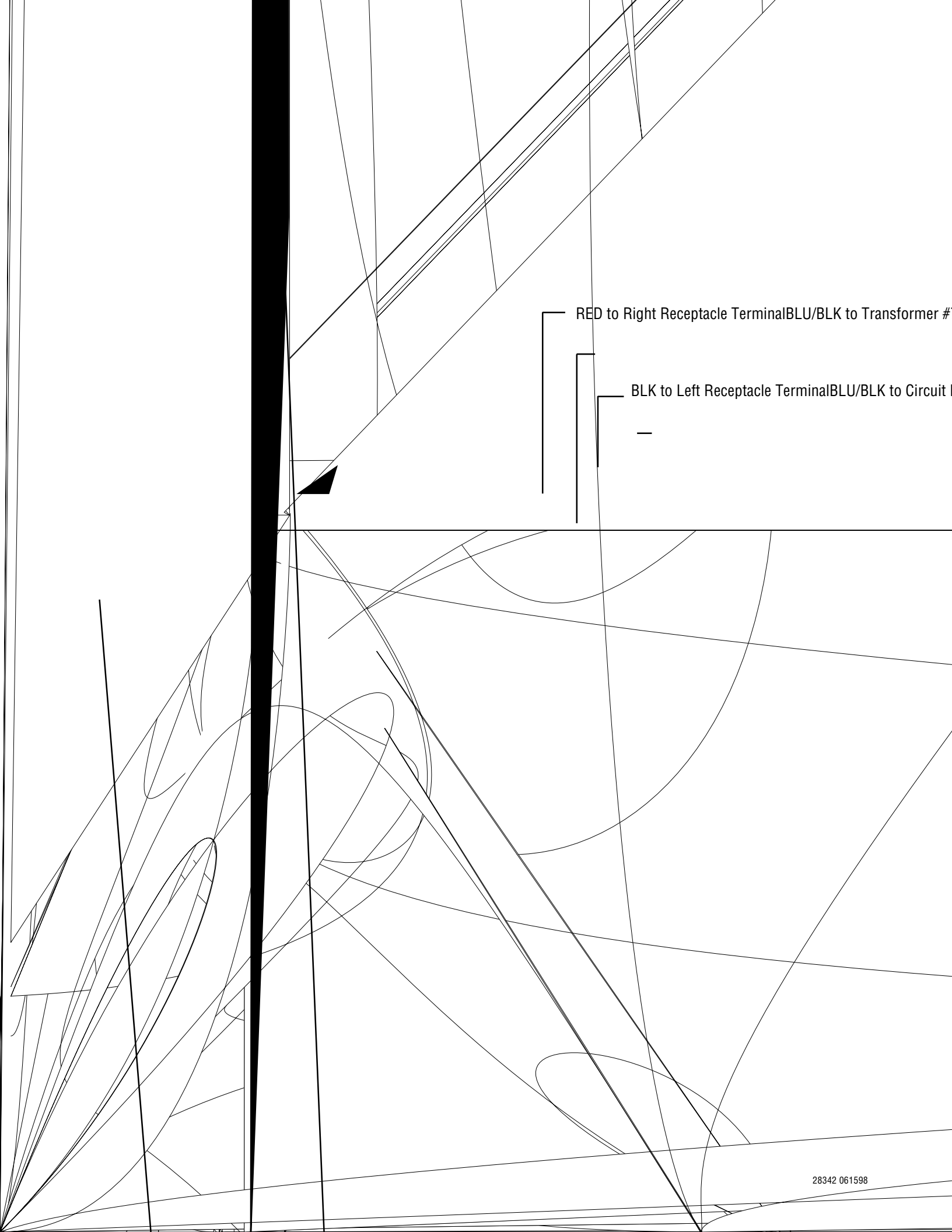

RED to Right Receptacle Terminal BLU/BLK to Transformer #

BLK to Left Receptacle Terminal BLU/BLK to Circuit #

SERVICE (cont.) TRANSFORMER

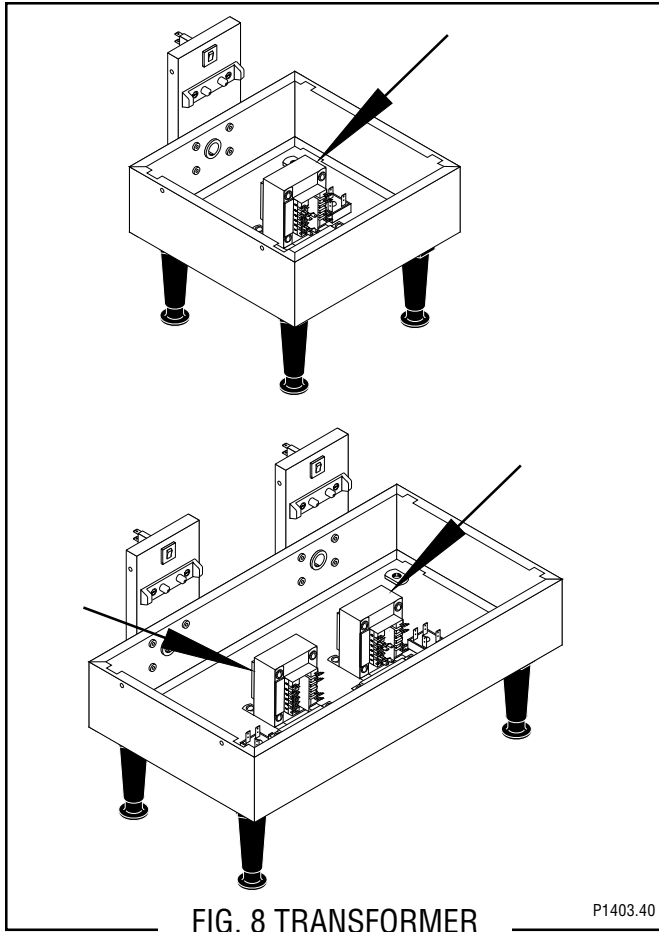

5. Disconnect the blue/black wires from terminals #7 and #12 on the transformer.
6. Check the voltage across terminal #7 and #12 of the transformer with a voltmeter. Connect the stand to the power source. The indication must be 24 volts ac.

If voltage is present as described the transformer is operating properly.

If voltage is not present as described, replace the transformer.

Removal and Replacement:

1. Disconnect all the wires from the transformer.
2. Remove the four #6-32 screws securing the transformer and mounting strap to the stand housing.
3. Remove transformer and discard.
4. Install new transformer in the stand housing securing with four #6-32 screws and mounting strap.
5. Refer to Fig. 9 when reconnecting the wires.

Location:

The transformer(s) is located in the stand housing on the base plate.

Test Procedures:

1. Disconnect the stand from the power source.
2. Disconnect the black wire from terminal #5 and the white or red wire from terminal # 6.
3. Check the voltage across the black and white or red wire with a voltmeter. Connect the stand to the power supply. The indication must be:
 - a.) 120 volts ac for two wire 120 volt models.
 - b.) 200 to 240 volts ac for two wire 200 or 240 volt models.
4. Disconnect the stand from the power supply.

If voltage is present as described reconnect the wires and proceed to #5.

If voltage is not present as described, refer to the wiring diagrams and check the stand wiring harness.

FIG.9 TRANSFORMER TERMINALS

SCHEMATIC WIRING DIAGRAM 1 SH STAND

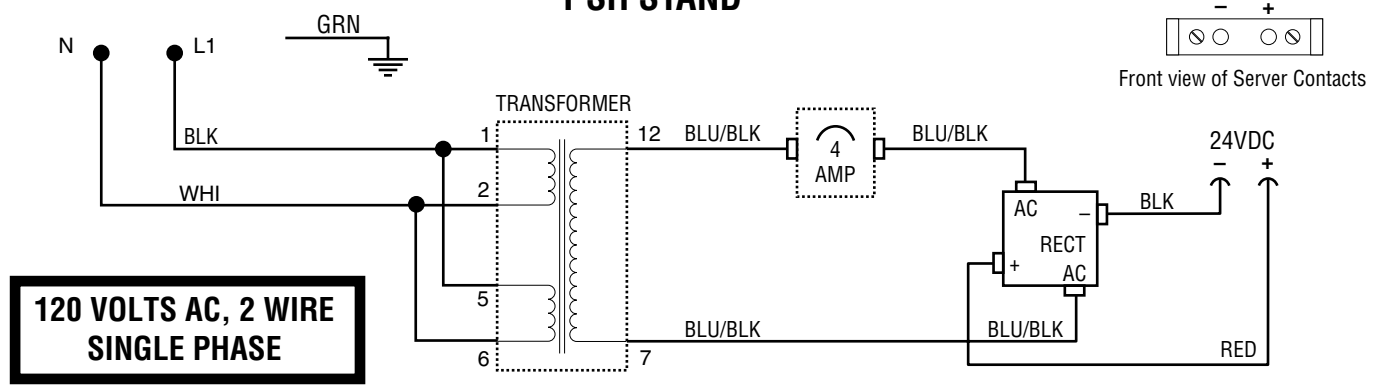

SCHEMATIC WIRING DIAGRAM 2 SH STAND

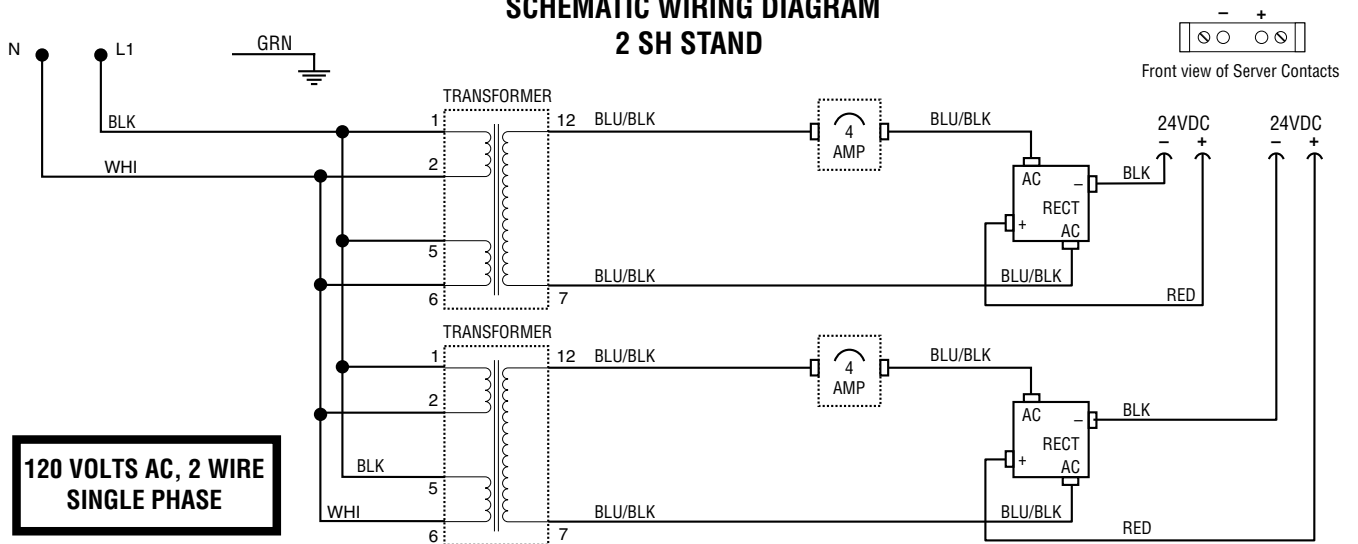

SCHEMATIC WIRING DIAGRAM 1 SH STAND, 230V CE

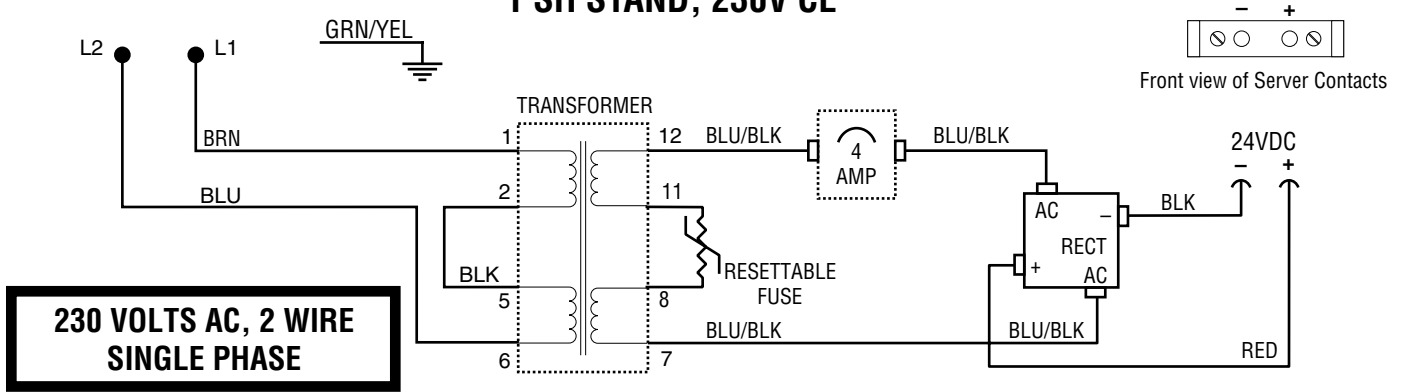

SCHEMATIC WIRING DIAGRAM 2 SH STAND, 230V CE

