

THIS INSTRUCTION BOOKLET CONTAINS
IMPORTANT SAFETY INFORMATION, PLEASE
READ AND KEEP FOR FUTURE REFERENCE.

Lot Number : _____

Date: _____

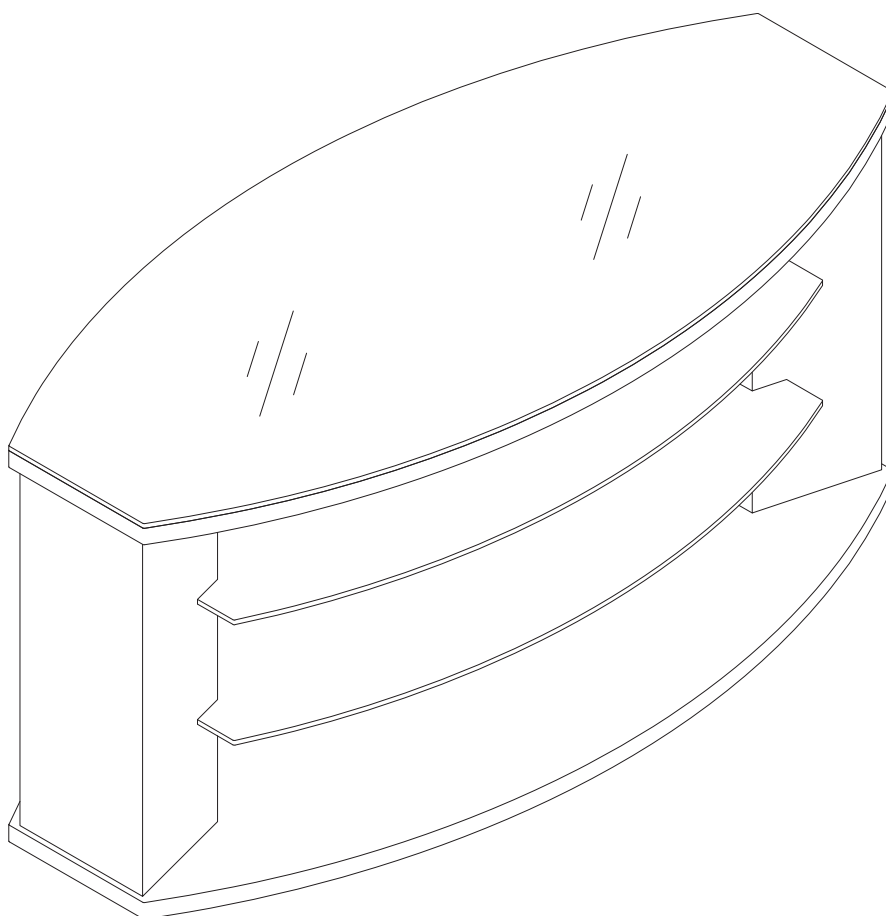

Item # 36835513
Metro TV stand

Fits PLASMA or LCD TV's that measure 37 to 42 inches. If parts are missing, DO NOT return to the store. To order missing / replacement parts or assembly assistance please call 1-800-747-2660 or mail customer_relations@atlantic-inc.com.

Assembly Tips:

Become familiar with the instructions and all parts.

Make sure that all parts are in the box and in good condition.

Assemble the product on the open flat carton or a rug to protect the product and your floor.

Some heavy products need a second person to assist in the assembly.

Use of power tools is not recommended.

It is strongly recommended that at least two people carry out the assembly.

Assemble the product close to a wall.

With each step, first insert and hand-tighten all bolts and screws by hand. After **ALL BOLTS** are slightly screwed in, fully tighten bolts with Phillips screwdriver in sequential pattern (clockwise or counter clockwise).



Caution:

Never let children climb on furniture or play with furniture.

Do not sit or stand on furniture.

Do not place a TV that is heavier than the recommended load rating on the furniture surface.

Do not overload shelves.

Use care when moving furniture. Furniture can tip over if moved improperly.

Only move furniture when it is empty of TV or other electronic components.

Handle items with glass with extra care. Use eye and hand protection.

Improper handling can result in cuts and lacerations.



Do not install on sloping surface.







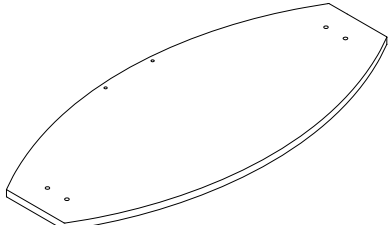
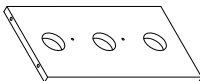

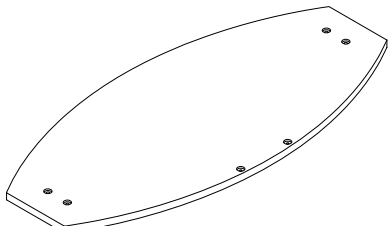
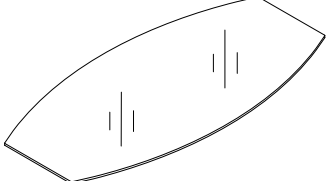
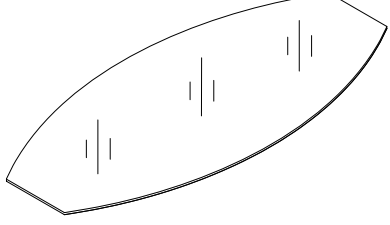



Care Instructions:

Use electrostatic dust cloths to clean furniture.

Do not set hot or cold containers directly on the furniture surface.

Part List

Item	Components parts list	Qty
A		1
B		1
C		2
D		4
E		1
F		2
G		1

Item	Components parts list	Qty
H		4
J		2
K		2
L		2
M		4
N		2
O		6
P		2
Q		8
R		8
S		1
T		1

Tool needed (not included)



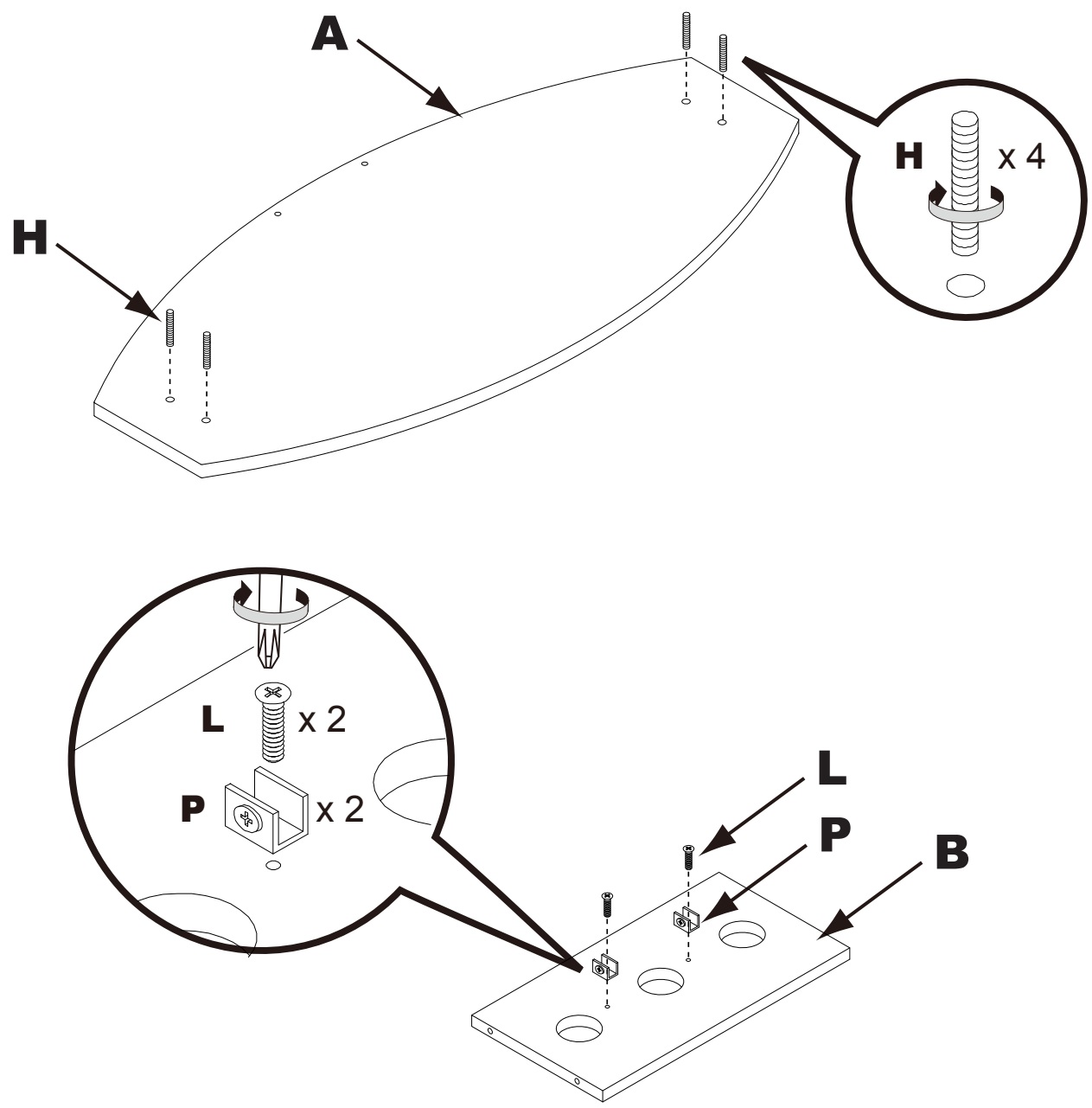
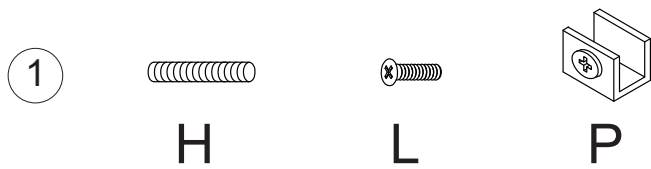

1. Fasten screw (H) to the top board (A). Fasten glass supporter (P) to the back board (B) with screw (L).

2

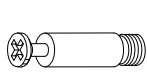

J



K

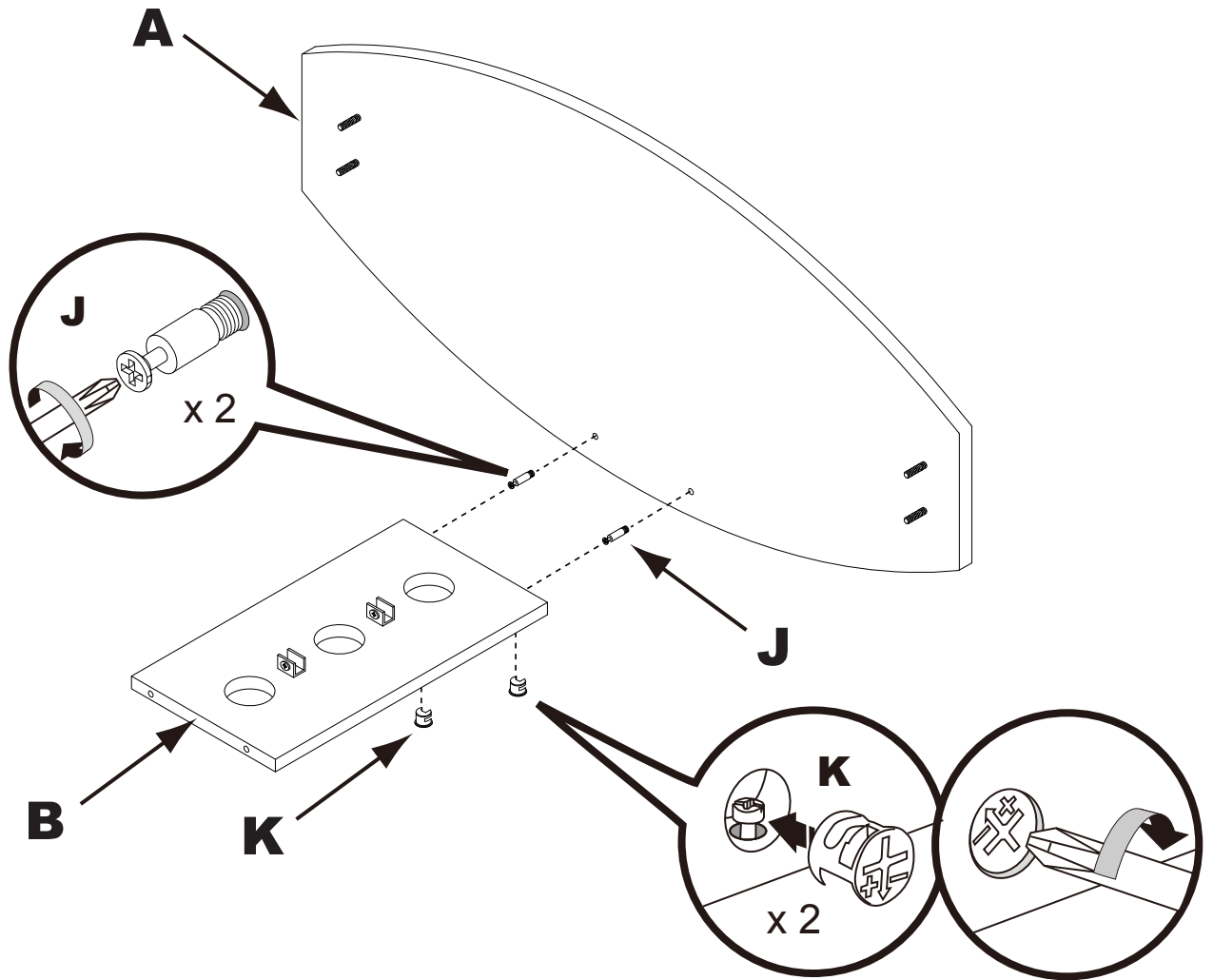

2. Attach back board (B) to the top boards (A) with screws (J), and cam locks(K). Turn cam lock(K) clockwise to secure.

3

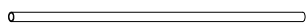

D

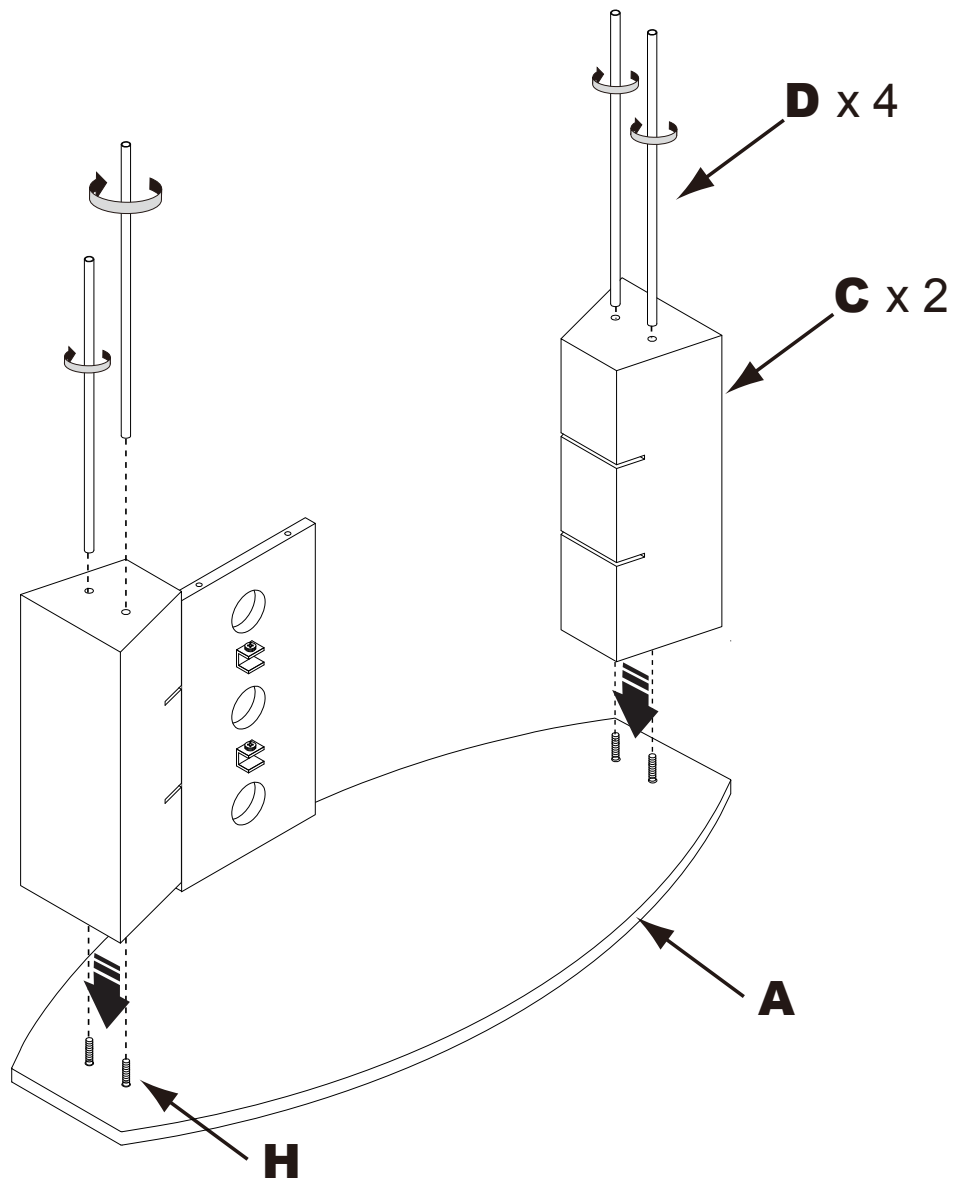

3. Fasten tube (D) to the top board (A) with screw (H) and turn clockwise to secure. Then put the side column (C) on the top board (A). Insert tubes (D) through side columns (C) and rotate clockwise to secure.

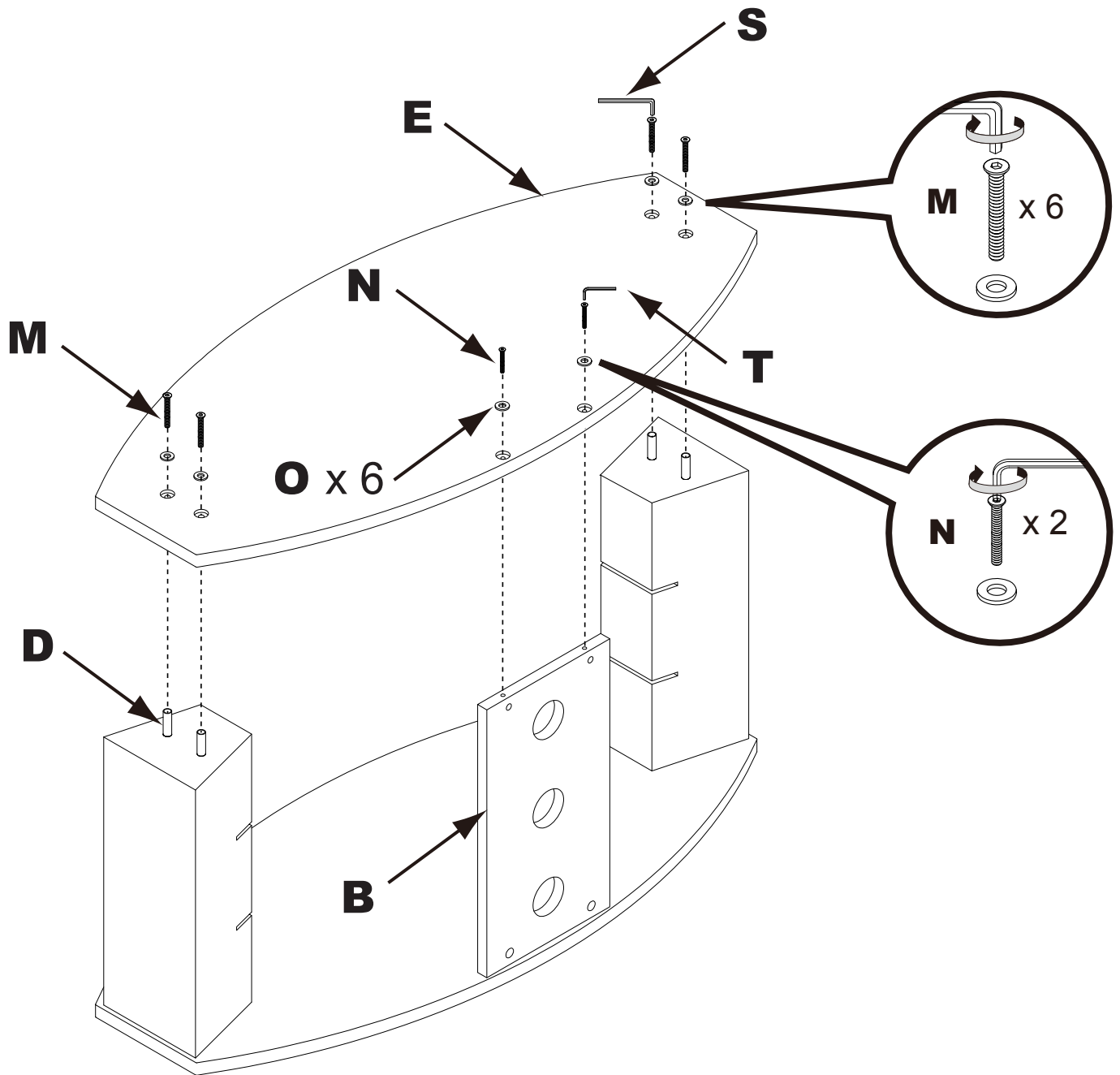
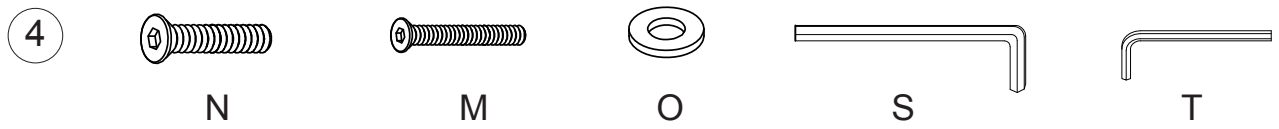

4. Fasten bottom board (E) to the tube (D) with screw (M) and washer (O), then secure to the back board (B) with screw (N) and washer(O).

5

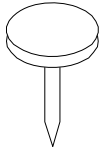

Q

Q x 8

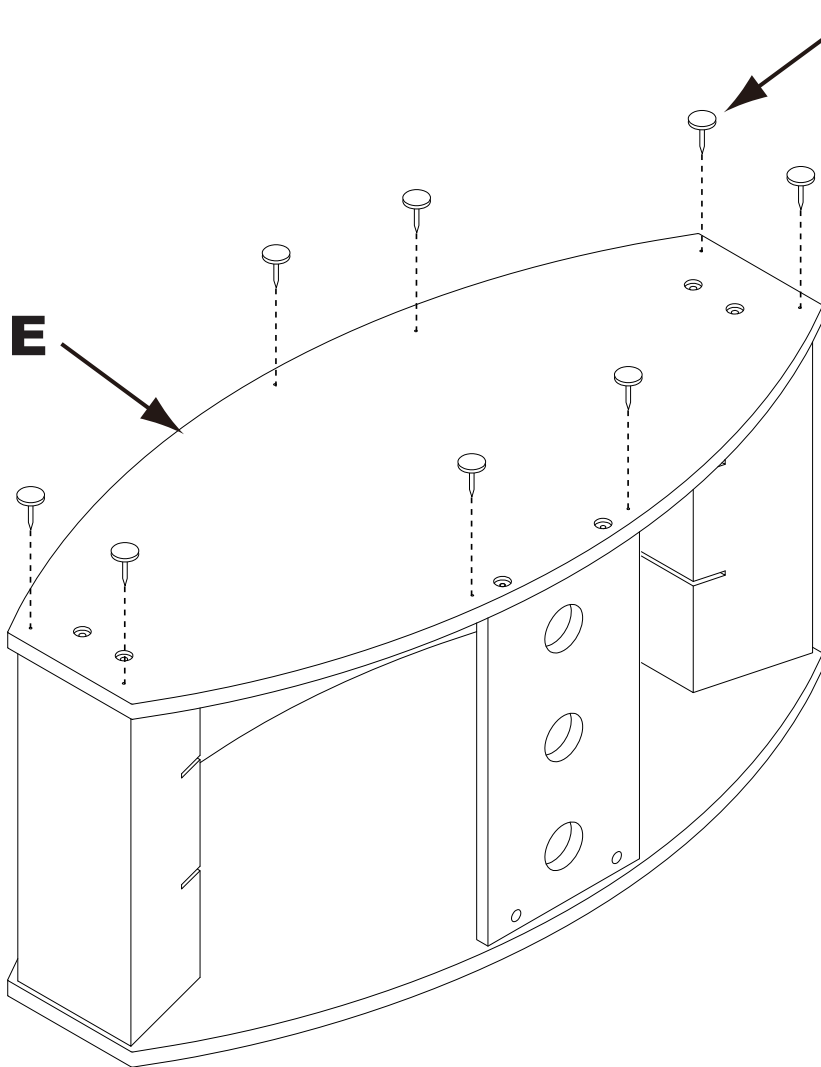

5. Place feet (Q) on bottom board (E).

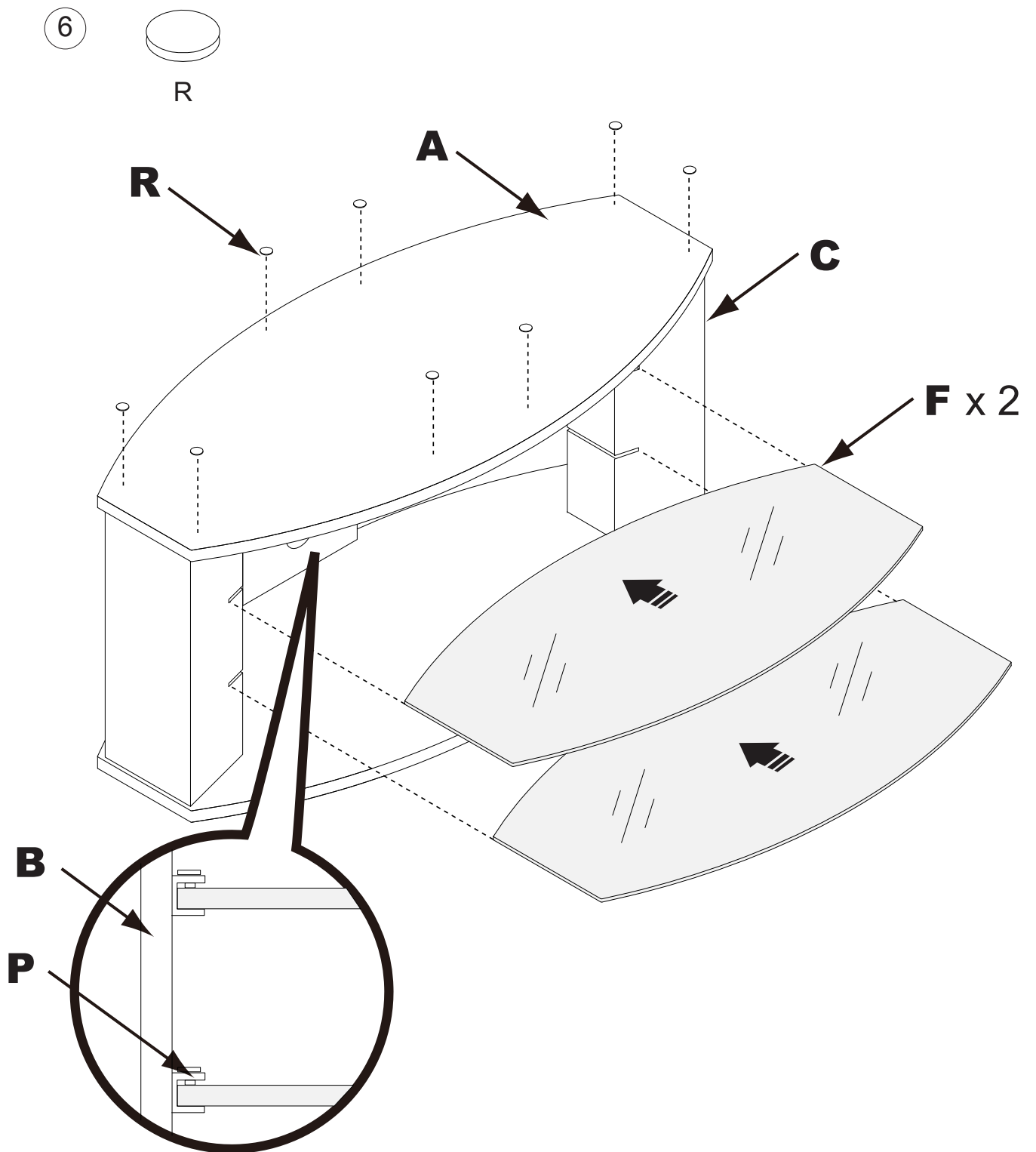

6, Place glass shelves(F) through slot in side columns (C) until they stop at back board (B) and rest in glass supporter (P). Place the glass protector (R) on the top board (A).

7

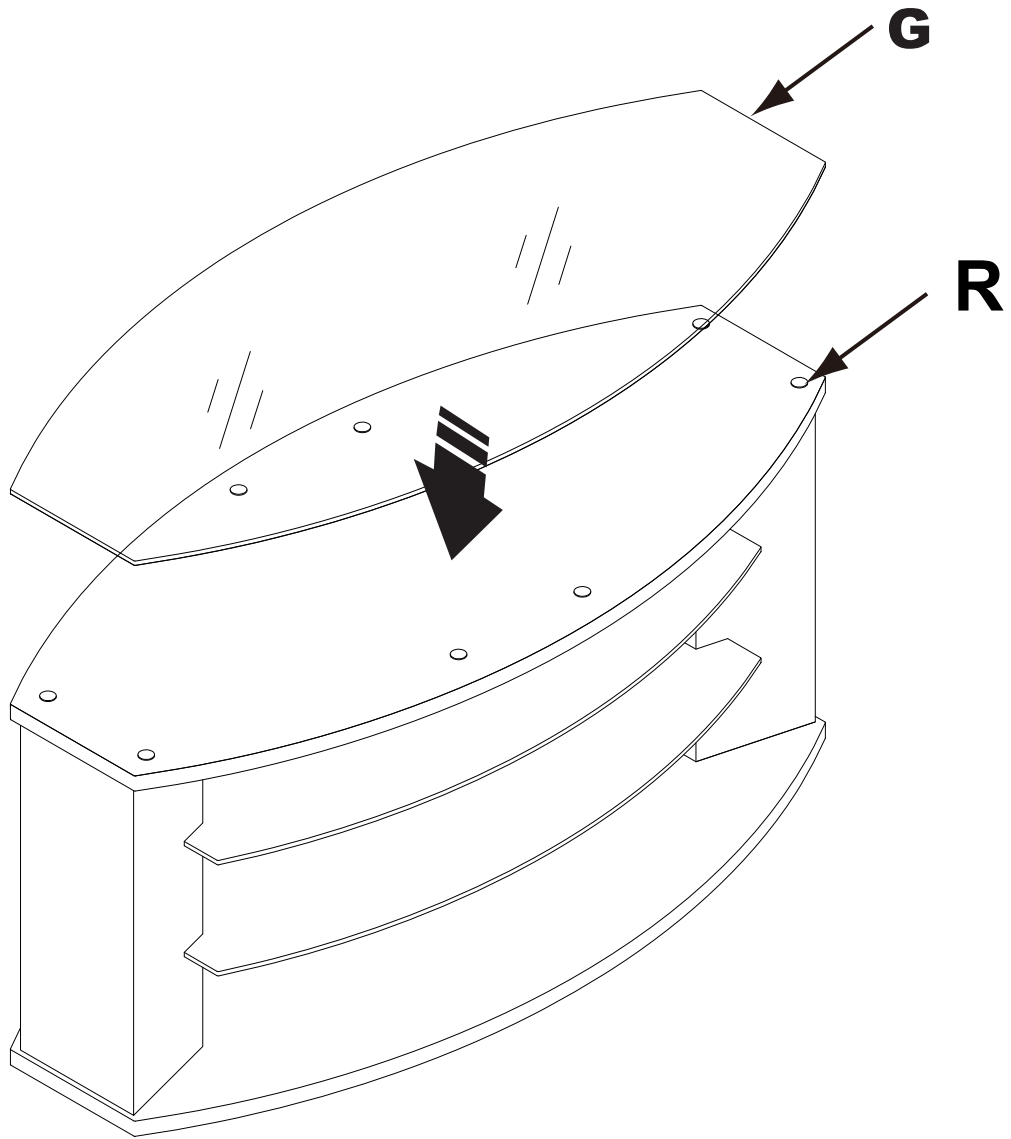

7. Place the top glass (G) on the glass protector(R).

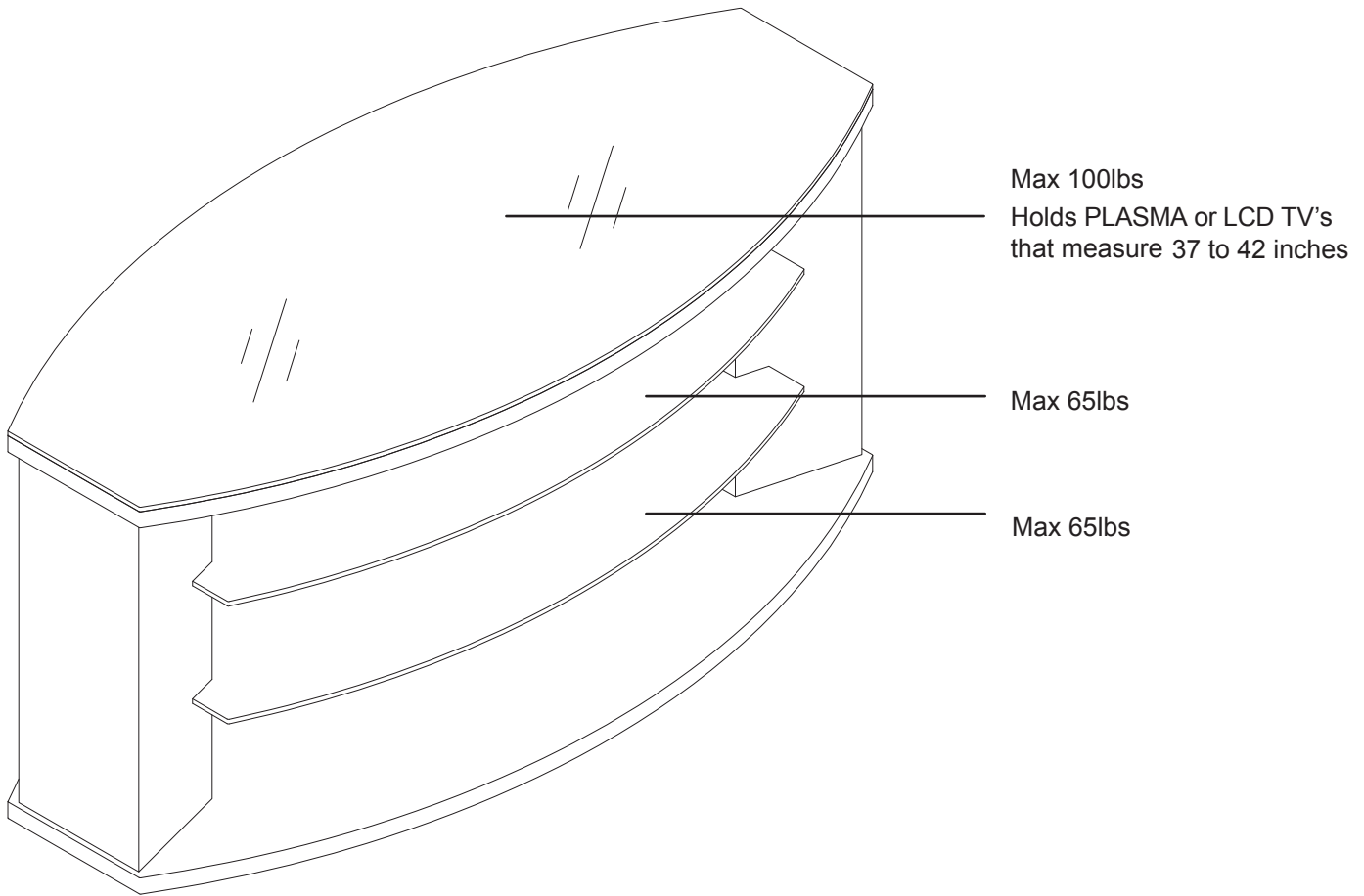

Product Warranty: Atlantic Inc., warrants to the original purchaser that its products are free from defect in materials or workmanship. If after inspection, we find that the product was defective in materials or workmanship, we shall repair or replace the product at our discretion. This warranty does not cover accidental damage, misuse, improper care or alteration and excludes claims for incidental or consequential loss. This limited warranty applies to product purchased in the U.S. and Canada. This warranty gives you specific legal rights and you may also have other rights which vary from State to State. This warranty duration will be last one year.

Keep this Instruction Manual for future reference.
Keep your original proof of purchase (store receipt).

If parts are missing, DO NOT return to the store.
To order missing / replacement parts or for assembly assistance please contact customer_relations@atlantic-inc.com.
Or call 1-800-747-2660 M-F, 8am-5pm, P.S.T.

ATLANTIC®

©2008 Atlantic Inc. Santa Fe Springs, CA, U.S.A.
U.S. and other foreign patents pending /
Patentes de los EUA y países extranjeros en trámite /
Brevets en cours pour les États-Unis et autres pays /
U.S. und andere ausländische Patente sind hängig

All rights reserved / Derechos Reservados /
Tous droits réservés / Alle Rechte vorbehalten

Made in China / Hecho en China /
Fabriqué en Chine / Hergestellt in China

www.atlantic-inc.com

R1.2 080820 # 36835513

