

Eclipse

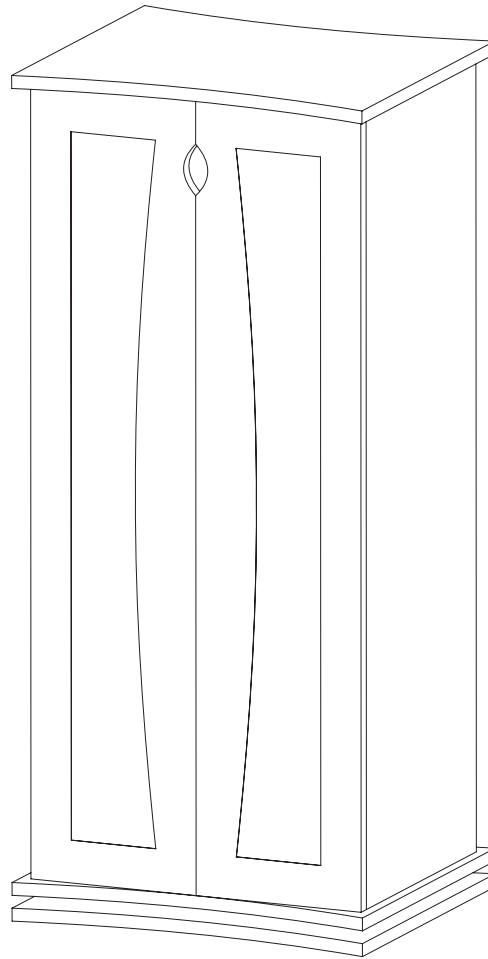







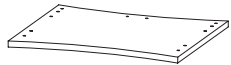

442 CD / 200 DVD

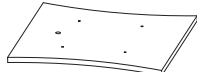

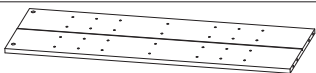
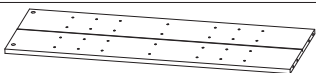



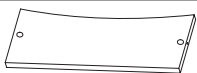

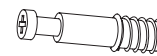

33335427

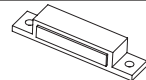
 ATLANTIC®

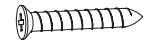
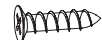
Assembly Instructions / Directives d'assemblage / Instrucciones:

PARTS LIST Lista de Componentes / Liste des pieces / Teilleliste:		QTY Cant. / Qté
A		1
B		1
C		1
D		1
E		1
F		1
G		1
H		1
I		8
I-A		2
J		1

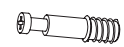
PARTS LIST Lista de Componentes / Liste des pieces / Teilleliste:		QTY Cant. / Qté
K		4
L		4
M		16
N		1
O		2
P		36
Q		4
R		2
S		2
T		8
U		4
V		4
W		4

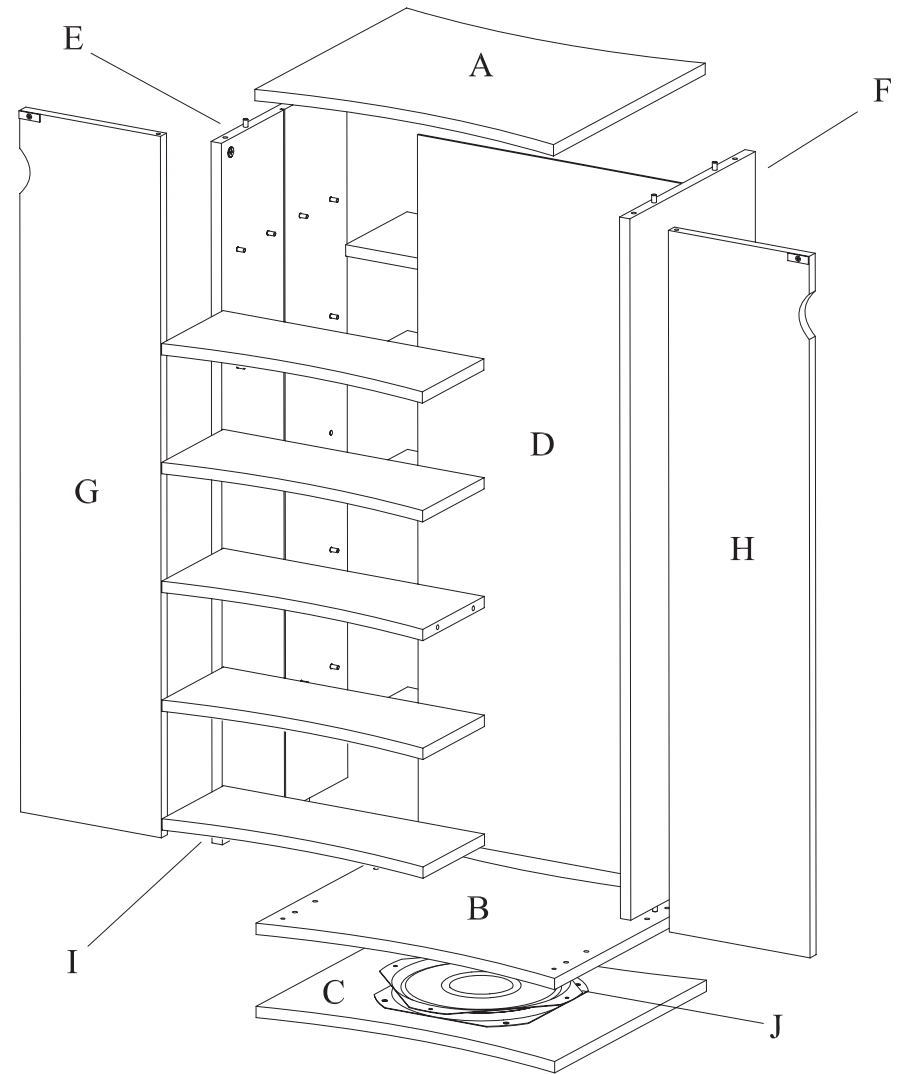

Tools needed / not included

Outils requis / non fournis
Herramientas requeridas / no incluidas

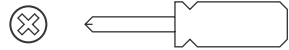

Phillips screwdriver
Tournevis Phillips
Desarmador de cruz (Phillips)

Tools included

Outils Inclus /
Las Herramientas Incluyeron



Hex Key /
Clef De Sortilège / Llave De Tuerca
hexagonal

ATLANTIC

©2007 Atlantic Inc.
Santa Fe Springs, CA, U.S.A.

U.S. AND OTHER FOREIGN PATENTS PENDING
Patentes de los EUA y países extranjeros en trámite
En sours pour Etats Unis et autres pays étrangers
U.S. und andere ausländische Patente sind hängig

ALL RIGHTS RESERVED
Derechos Reservados / Tous droits réservés /
Alle Rechte vorbehalten

www.atlantic-inc.com

MADE IN CHINA

Hecho en China / Fabriqué en Chine /
Hergestellt in China

R5.1 070412 # 33335427



1

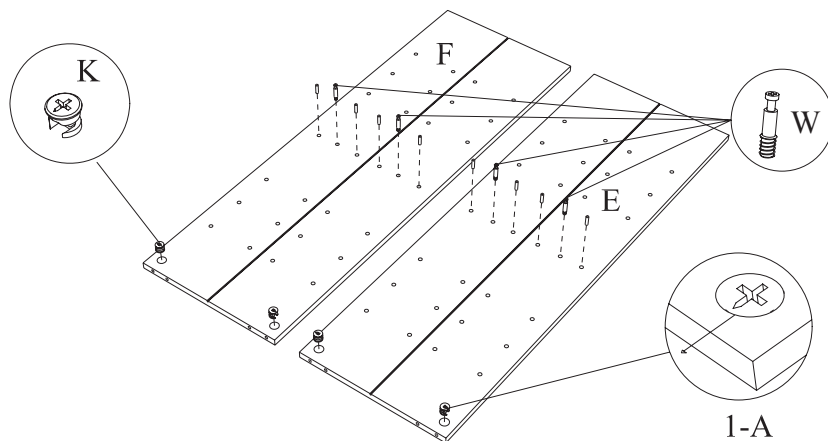

1 - Insert (K) into panels (E) and (F). Arrows should point towards screw opening, see diagram (1-A).
 Insérez (K) dans les montants (E) et (F). Les flèches doivent pointer vers l'ouverture prévue pour la vis, voir le schéma (1-A).
 Inserte (K) en los paneles (E) y (F). Las flechas deben siempre apuntar hacia la perforación para el tornillo. Véase diagrama (1-A).

Insert CAM screw (W) into (E) and (F). Insert dowels (M) into the holes as shown.
 Insérez une vis à came (W) dans (E) et (F). Insérez les gougeons en bois (M) dans les trous, tel qu'illustré.

Meta el tornillo cam (W) a (E) y (F). Inserte las clavijas (M) en los agujeros según lo mostrado.

3

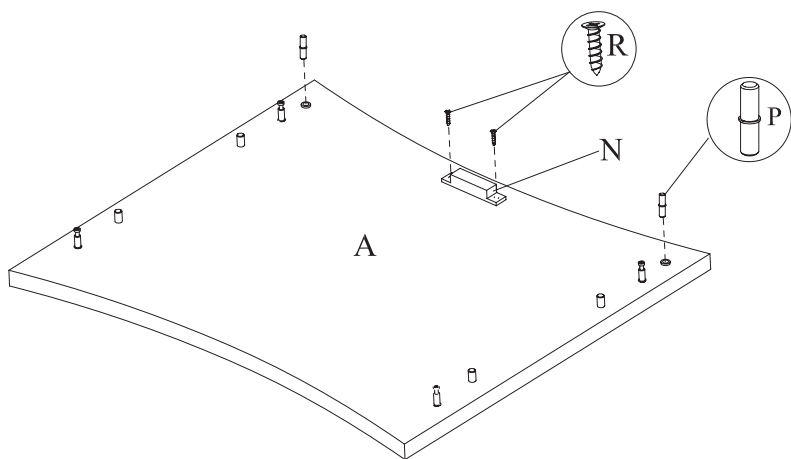

3 - Fasten (N) to panel (A) with screws (R). Insert pins (P) into the holes.
 À l'aide des vis (R), fixez (N) sur le panneau (A). Insérez les broches (P) dans les trous.
 Sujete (N) al panel (A) usando los tornillos (R). Inserte los pasadores (P) en los agujeros.

2

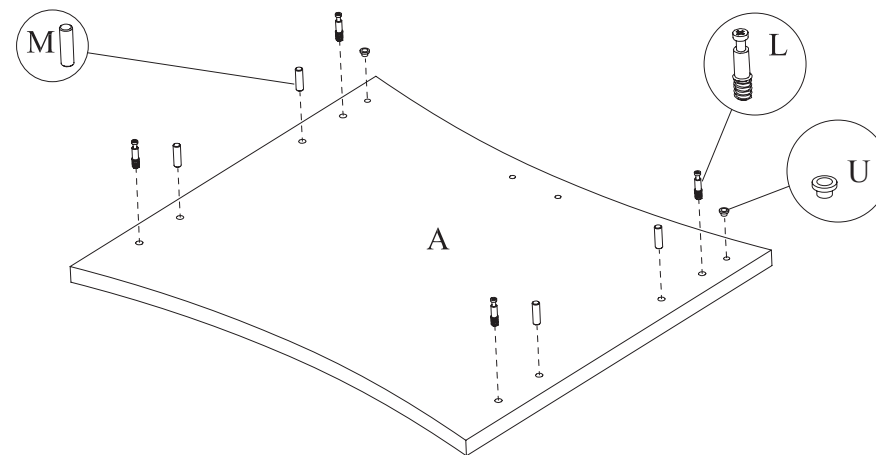

2 - Insert CAM screw (L) into (A). Insert dowels (M) and plastic inserts (U) into the holes as shown.
 Insérez une vis à came (L) dans (A). Insérez les gougeons en bois (M) et les gaines de plastique (U) dans les trous, tel qu'illustré.

Meta el tornillo cam (L) a (A). Inserte las clavijas (M) y las inserciones de plástico (U) en los agujeros según lo mostrado.

4

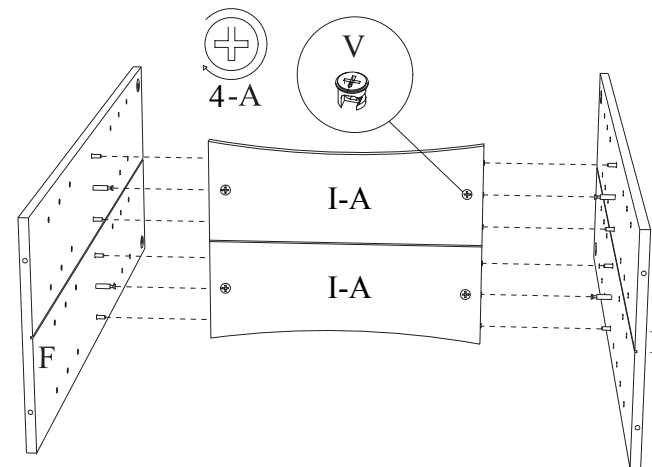

5 - Attach panels (E) and (F) to panel (I-A). Turn cam locks (V) clockwise to secure. See diagram (4-A).
 Fixez les panneaux (E) et (F) au panneau (I-A). Tournez les serrures à came (V) dans le sens des aiguilles d'une montre pour maintenir en place. Voir le schéma (4-A).
 Conecte los paneles (E) y (F) al panel (I-A). Dé vuelta a las cerraduras de leva en el sentido de las manecillas del reloj para asegurarlas. Véase el esquema (4-A).

5

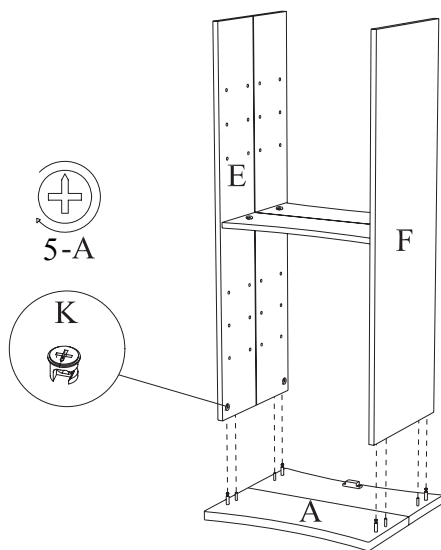

- 5 - Attach panels (E) and (F) to panel (A). Turn cam locks (K) clockwise to secure. See diagram (5-A).
 Fixez les panneaux (E) et (F) au panneau (A). Tournez les serrures à came (K) dans le sens des aiguilles d'une montre pour maintenir en place. Voir le schéma (5-A).
 Conecte los paneles (E) y (F) al panel (A). Dé vuelta a las cerraduras de leva en el sentido de las manecillas del reloj para asegurarlas. Véase el esquema (5-A).

6

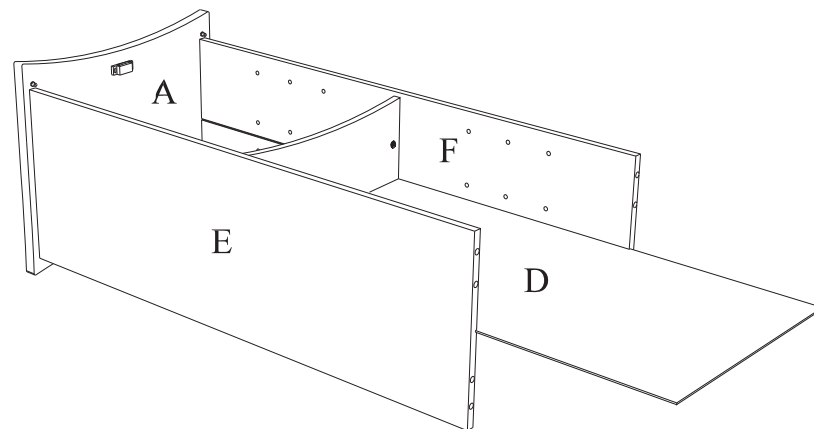

- 6 - Slide middle panel (D) into groove in panels (E) and (F).
 Glissez le panneau du centre (D) dans la rainure des panneaux (E) et (F).
 Pase el panel de en medio (D) por la ranura en los paneles (E) y (F).

7

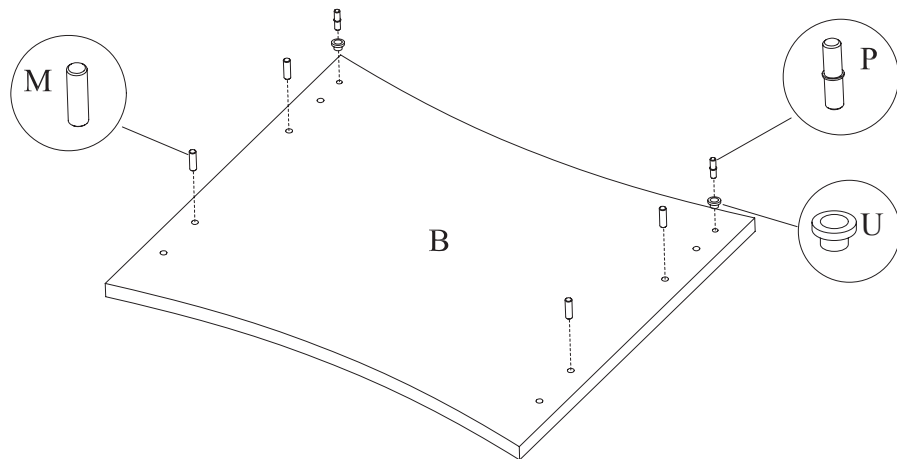

- 7 - Insert wood dowels (M) into panel (B). Insert plastic inserts (U) and then pins (P) into the holes as shown.
 Insérez les gougeons en bois (M) dans le panneau (B). Insérez les gaines de plastique (U) et ensuite les broches (P) dans les trous, tel qu'illustré.
 Meta las clavijas de madera (M) el panel (B). Inserte las inserciones de plástico (U) y después los pasadores (P) según lo mostrado en los agujeros.

8

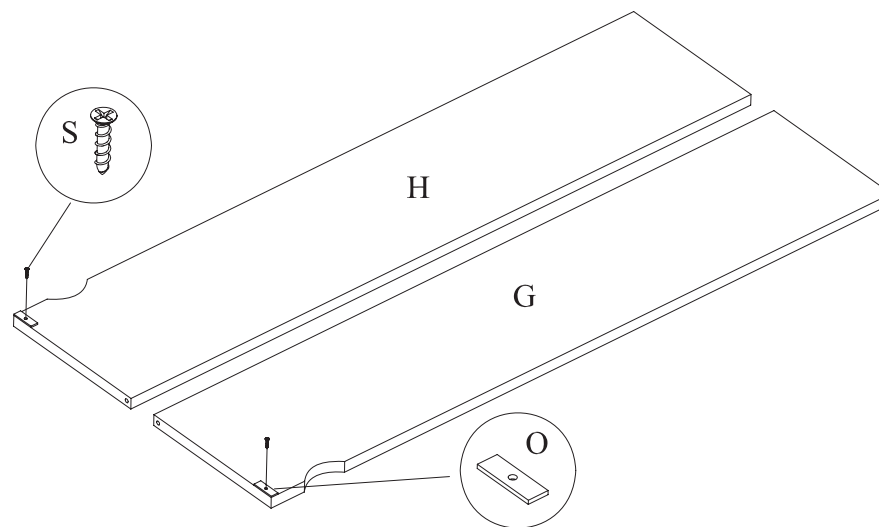

- 8 - Fasten metal plates (O) to top corner of doors with screws (S).
 Fixer la plaque de métal (O) au coin supérieur des portes à l'aide de vis (S).
 Sujeter la chapa de metal (O) a la esquina superior de las puertas con los tornillos (S).

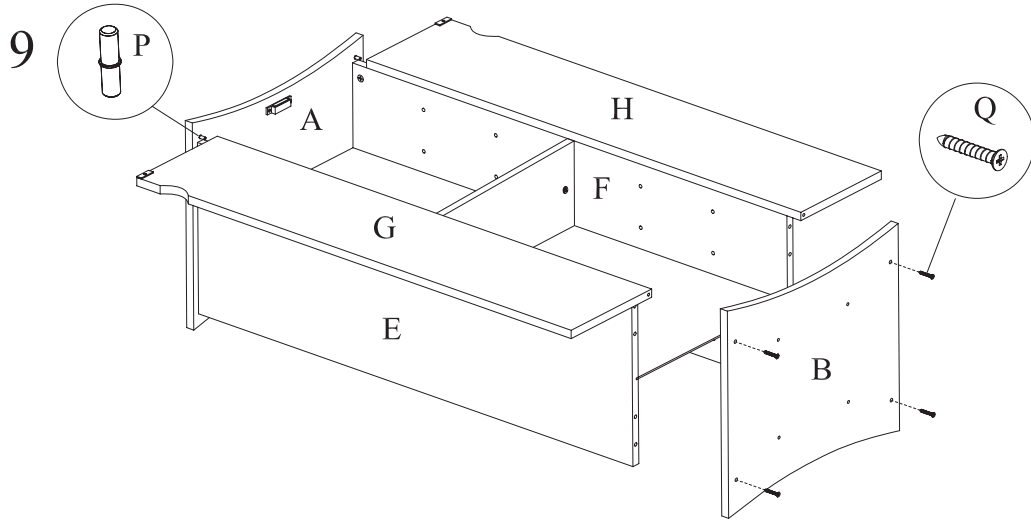

9 - Attach doors (G) and (H) to (A) and (B) with pins (P). Fasten bottom shelf (B) to (E) and (F) with screws (Q).
 À l'aide des broches (P), placez les portes (G) et (H) sur (A) et (B). Fixez le rayon du bas (B) à (E) et (F) à l'aide de vis (Q).
 Una las puertas (G) y (H) a (A) y (B) con los pasadores (P). Apriete el estante inferior (B) al (E) y (F) con tornillos (Q).

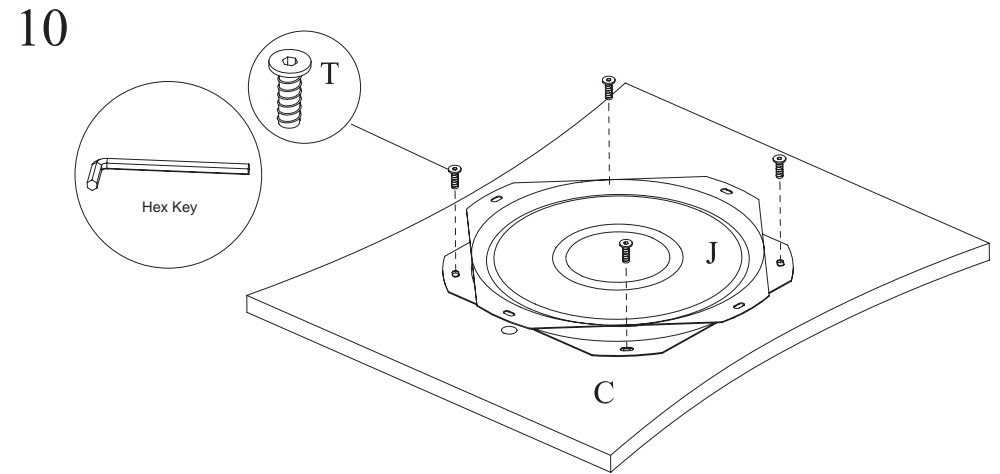

10 - Fasten rotating bracket (J) onto the lower base (C) with screws (T) using provided tool (Hex Key).
 À l'aide de l'outil fourni (clé hexagonale) et des vis (T), vissez le support pivotant (J) dans la base du bas (C).
 Sujete el soporte rotatorio (J) en la base inferior (C) con los tornillos (T) usando la herramienta proporcionada (llave hexagonal).

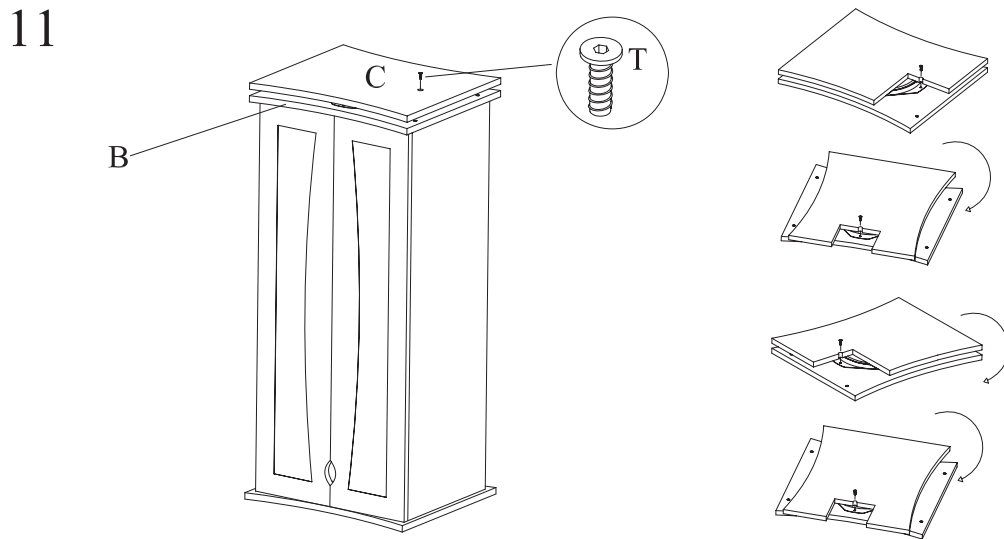

11 - Attach lower rotating base (C) to (B) by inserting and tightening screws (T) through access holes, one at a time.
 Fixez la base pivotante du bas (C) sur (B) en insérant et en serrant les vis (T) dans les trous d'accès, une à la fois.
 Una la base rotatoria inferior (C) a (B) al insertar y apretar los tornillos (T) a través de los agujeros de acceso, uno por uno.

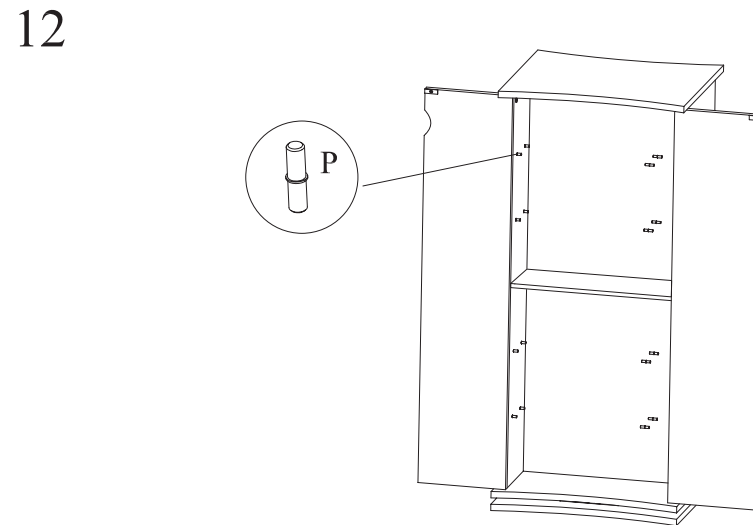

12 - Insert pins (P) at desired heights.
 Insérez les pines (P) a la altura deseada.
 Insérez les taquets (P) à la hauteur désirée.

13

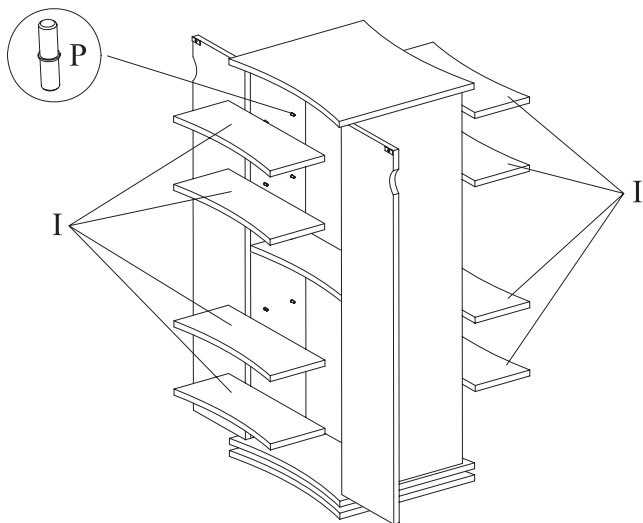

13 - Place shelves (I) on pins (P).
 Coloque los estantes (I) sobre los pines (P).
 Placez les rayons (I) sur les taquets (P).

14

Front

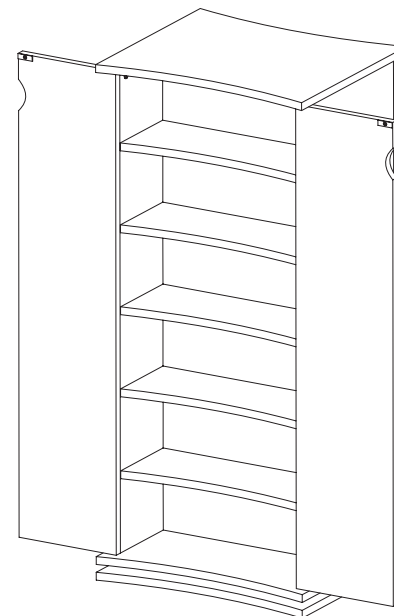

15

Back

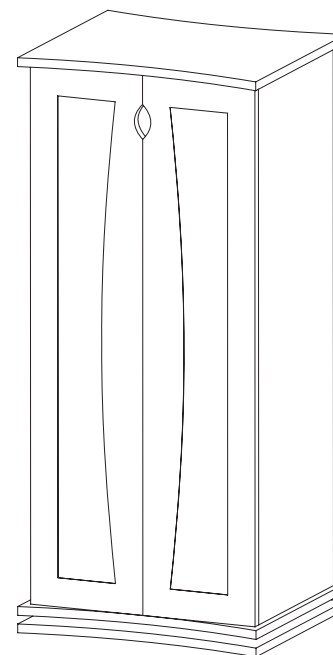
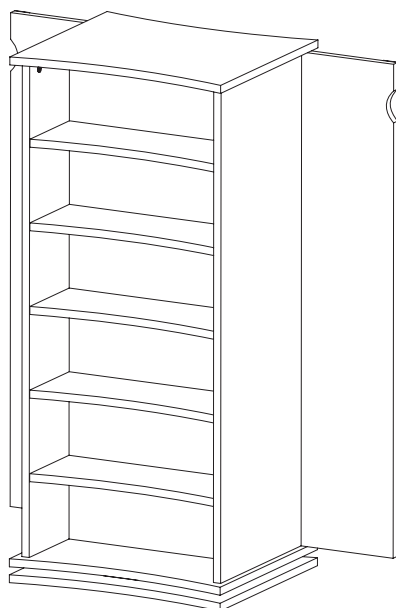

ATLANTIC®

©2007 Atlantic Inc.
 Santa Fe Springs, CA, U.S.A.

U.S. AND OTHER FOREIGN PATENTS PENDING
 Patentes de los EUA y países extranjeros en trámite
 En sours pour Etats Unis et autres pays étrangers
 U.S. und andere ausländische Patente sind hängig
 ALL RIGHTS RESERVED
 Derechos Reservados / Tous droits réservés /
 Alle Rechte vorbehalten

www.atlantic-inc.com

MADE IN CHINA

Hecho en China / Fabriqué en Chine /
 Hergestellt in China

R5.1 070412 # 33335427

