



GENERAL DESCRIPTION:

Exposed, Battery Powered, Sensor Operated Selectronic™ Water Closet Flush Valve for floor-mounted or wall-hung 1-1/2" top spud bowls.

Inlet includes 1" I.P.S. angle stop with vandal-resistant cap, sweat solder kit, cover tube and wall flange.

Outlet includes 1-1/2" vacuum breaker with adjustable tailpiece, spud coupling and flange.

PRODUCT FEATURES:

- Electronic flush valve with Selectronic™ proximity system for "Hands Free" operation
- Self-Cleaning Piston operation helps prevent clogging and reduces maintenance
- Positive seal ensures leak-free performance
- Fully mechanical Manual Override Button can flush toilet during a power outage
- Range can be adjusted manually or by remote control
- Sensor & electronic controls are fully enclosed and water resistant
- Automatically flushes after 24 hours of non-use to maintain trap seal
- Safety timer helps prevent vandalism by turning off the valve if sensor is covered for more than 1 minute
- 3-second Flush Delay
- Low Battery indicator
- Battery can be changed without turning off the water
- Factory-installed 6V lithium battery included
- Can be installed left or right-handed
- ADA compliant

MODEL NUMBER:

- ❑ **6065121.002** Flush Valve for 11-1/2" Supply C\I to top of bowl, 1.28 gpf
- ❑ **6065122.002** Flush Valve for 27" Supply C\I to top of bowl, 1.28 gpf
- ❑ **6065525.002** Retrofit for Existing Flush Valves, 1.28 gpf. Replaces industry standard manual and electronic valves. Does not include the vacuum breaker assembly, angle stop or sweat solder kit.

OPERATING PRESSURE:

Overall Range: 20-125 psi
Recommended: 35-80 psi

BATTERY LIFE:

Up to 4-year life, (approx. 200,000 cycles)

ACCESSORIES:

- Cast wall flanges (3/4", 1" & 1-1/2")
- Solid ring pipe supports (2-1/2" & 6" C-E)
- Split ring pipe supports (2-1/2" & 6" C-E)



**TYPICAL WATER CLOSET INSTALLATION:
AFWALL™ TOILET SHOWN**

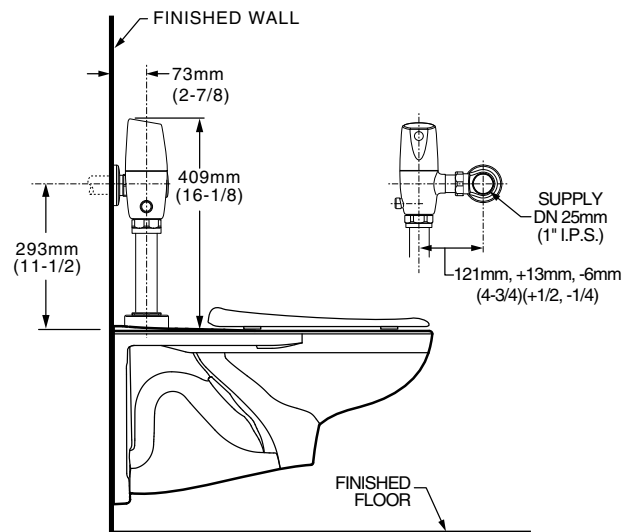

RECOMMENDED SPECIFICATION:

Electronic proximity infrared sensor activated toilet flush valve shall feature self-cleaning piston valve. Includes a fully mechanical manual over-ride that can provide a complete flush without battery power. Includes cast brass valve body and metal cover with chrome finish, vandal resistant stop cap and lithium battery. Angle stop and vacuum breaker included. 1.28 gpf / 4.8 Lpf Flush valve shall be American Standard Model # 6065.12_.002.

LISTINGS:

- ASSE 1037
- ANSI/ASME A112.19.2
- ADA Compliant

Roughing-in Dimensions

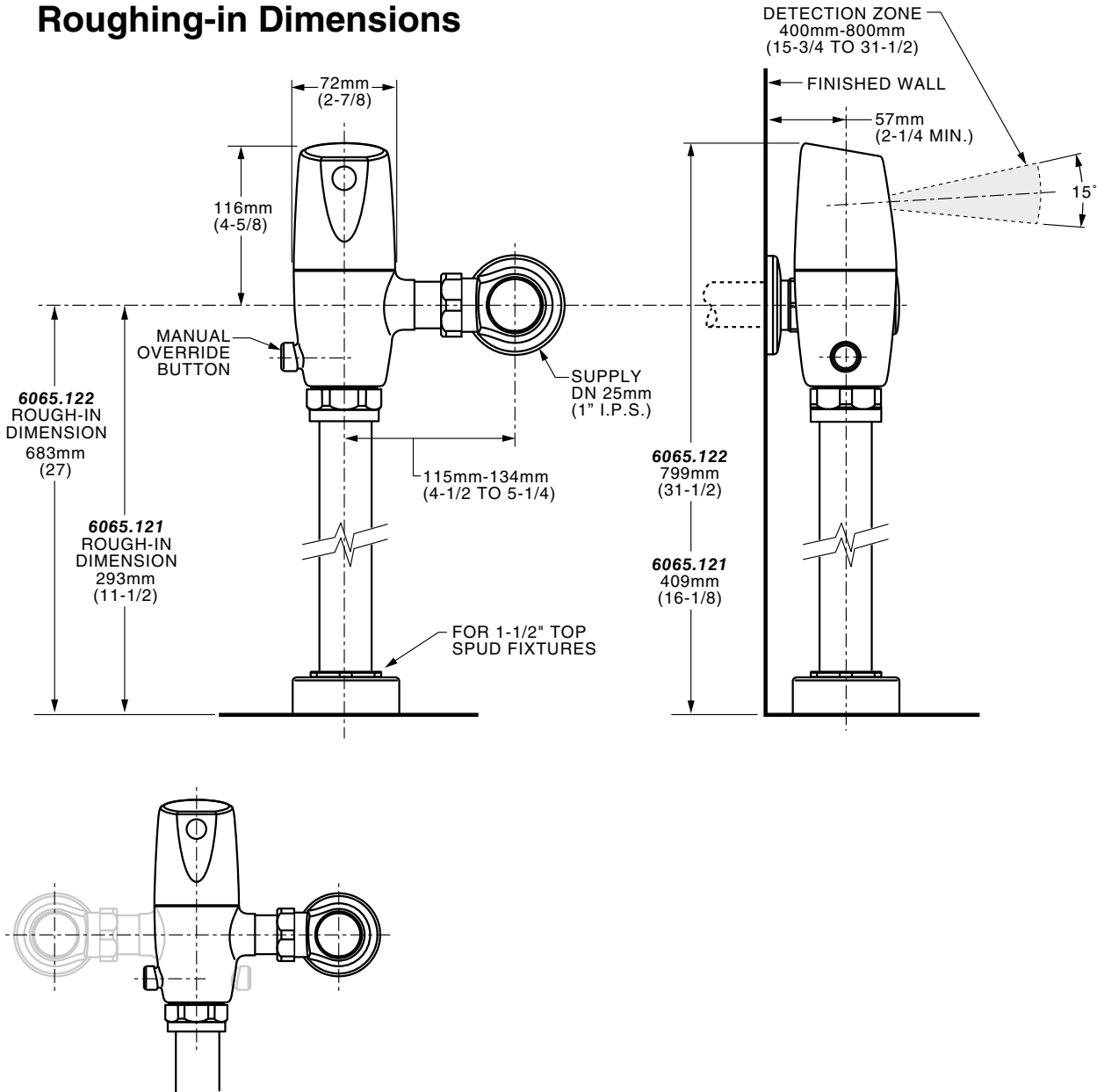

Right or Left Hand Installation