



GENERAL DESCRIPTION:

Electronic faucet with proximity operation. Vandal-resistant solid brass construction single post mounting. Operates on DC (battery) or AC permanent power. Water pressure range from 20 to 125 psi. Single inlet 15" flexible stainless steel hose with 3/8" compression fitting for spout connection.

PRODUCT FEATURES:

Vandal-Resistant Brass Body: Durable - Excellent in high use applications.

Power Options:

- **Battery** - Approx. 4 years with Lithium Battery CR-P2
- **Plug-In - Integral** low voltage transformer (115 VAC supply) with 6 foot longpower supply.

Easy and Flexible Installation:

Single post mounting. Water resistant solenoid enclosure mounts to wall.

Integrated; Easy Service Strainer:

Patented integrated strainer enclosed in removable debris cup protects the solenoid valve and aerator from debris. Perforated stainless steel strainer is low maintenance and can be easily accessed.

Temperature Mixing:

Optional thermostatic mixing valve meets ASSE 1016 performance and anti-scald requirements at 0.5 GPM. Mixing valve will connect directly to solenoid inlet and is housed in matching enclosure.

End Device:

Choice of 1.5 GPM (5.7 L/min) pressure compensating, vandal-resistant aerator or 0.5 GPM (1.9 L/min) pressure compensating, vandal-resistant spray.

CODES AND STANDARDS:

These products meet or exceed the following codes & standards:

- ANSI A117.1
- ASME A112.18.1
- CSA B 125
- NSF 61/Section 9



MODEL NUMBER:

- **DC POWERED; single inlet**
 - 2506.155 with cast spout, 0.5 GPM pressure compensating, vandal-resistant spray.
 - 2506.153 with cast spout, 1.5 GPM pressure compensating, vandal-resistant aerator.
- **AC POWERED; single inlet**
 - 2506.165 with cast spout, 0.5 GPM pressure compensating, vandal-resistant spray. Includes AC power supply.
 - 2506.162 with cast spout, 1.5 GPM pressure compensating, vandal-resistant aerator. Includes AC power supply.
- **MULTI AC POWERED; single inlet**
 - 2506.175 with cast spout. 0.5 GPM pressure compensating, vandal-resistant spray. One power supply (sold separately) can operate up to 15 faucets in series. 10' extension cable included.
 - 2506.172 with cast spout. 1.5 GPM pressure compensating, vandal-resistant aerator. One power supply (sold separately) can operate up to 15 faucets in series. 10' extension cable included.
- **OPTIONAL Mixing Valve**
 - 605XTMV Thermostatic mixing valve, flex hoses 3/8" compression 20" hose length.

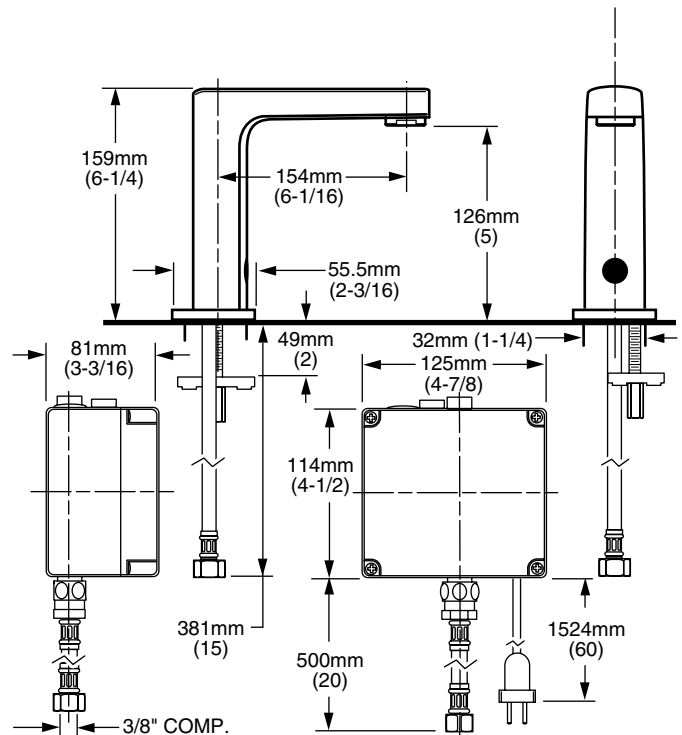

RECOMMENDED SPECIFICATION

Electronic Proximity Lavatory shall feature vandal resistant all brass body with single inlet, and in-line strainer. Shall also feature a low energy use electronically operated solenoid valve and microprocessor controlled proximity sensors. Shall meet ANSI A112.18.1M and ANSI 117.1 codes. Fitting shall be American Standard Model # 2506.____.