

## COMBO VALVE AND TURRET FITTINGS

Thank you for selecting American-Standard...the benchmark of fine quality for over 100 years. To ensure that your installation proceeds smoothly—please read these instructions carefully before you begin.



M968486

### ROUGHING-IN DIMENSIONS

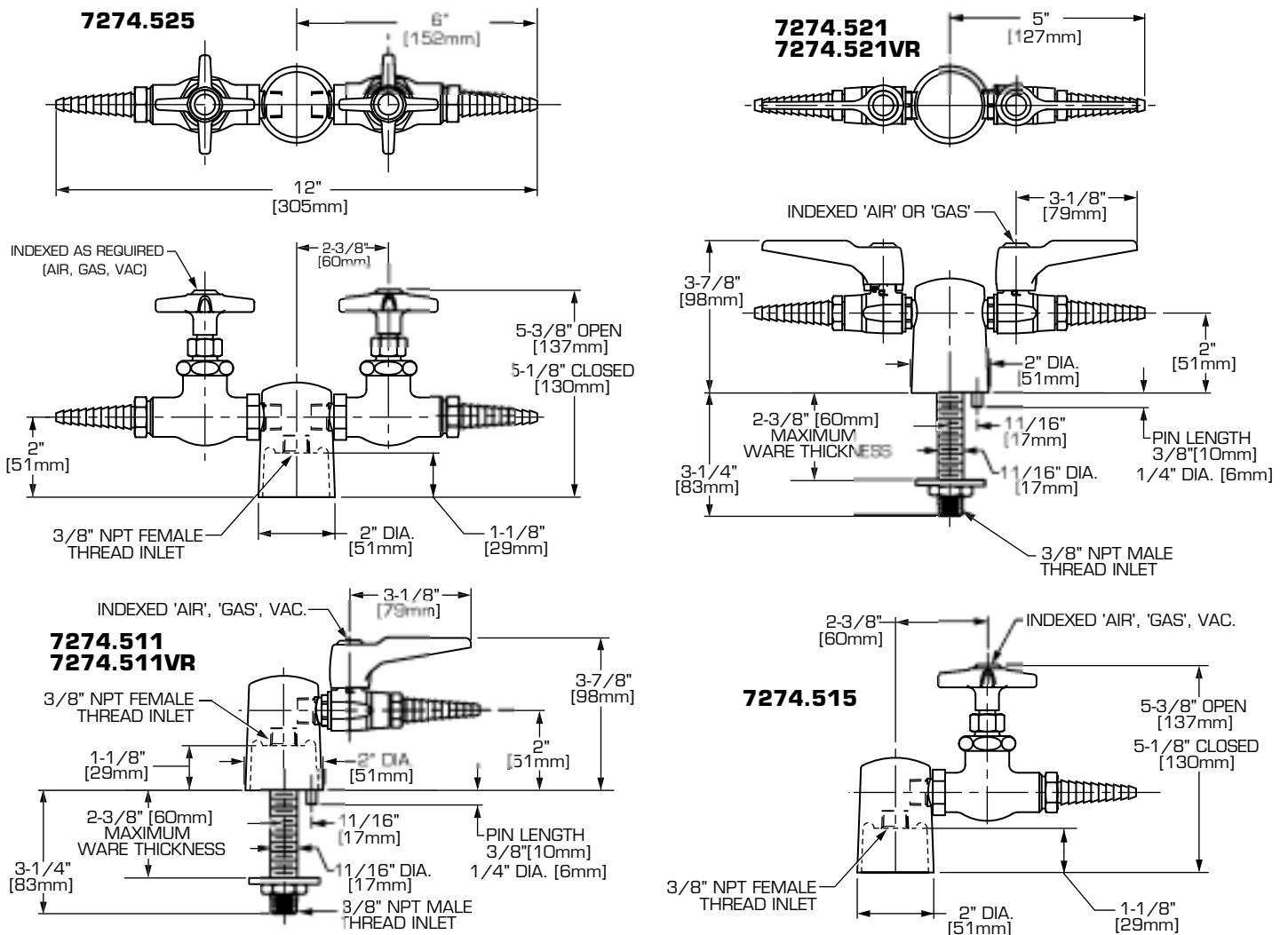

## TOOLS AND SUPPLIES REQUIRED



Channel Locks



Adjustable Wrench

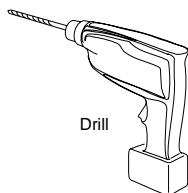

Drill



Teflon Tape



Plumbers' Putty or  
Caulking

## 1 COMBO VALVE TURRET FITTINGS AND VANDAL RESISTANT

**IMPORTANT: FLUSH ALL SUPPLY LINES PRIOR TO FITTING INSTALLATION.**

For vandal resistant fitting only, a pin hole will need to be drilled into the deck offset from the mounting shank hole.  
**Note: For vandal resistant models it is important to obtain the rough-in drawing for the particular model. The drawing illustrates exact size and positioning of the offset hole. Drill a 5/16" [8mm] dia. hole 1/2" [13mm] deep in mounting surface, per roughing-in dimensions for vandal resistant pin.**

**Note: 7274.515/525 require inlet shank M962323-0070A for installation and must be ordered separately.**

- Apply **putty** to underside of **turret body** to assure a good seal and level fit.
- If installing a vandal resistant fitting, align **pin** with **pin hole** in mounting surface.
- Place **body shank** through hole in deck and assemble **steel washer** and **lock nut**. **Tighten** securely.
- Pipe to correct service to complete installation.
- After installation is complete turn service on and check all connections for leaks.

**M962323-0070A**  
3/8" NPT X 4-3/4"  
INLET SHANK WITH  
LOCKNUT & WASHER

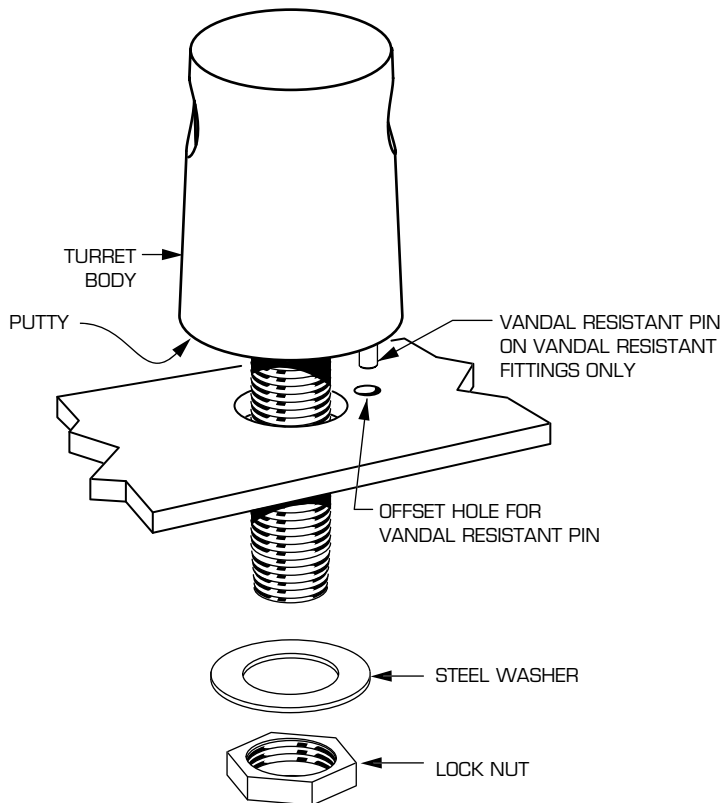
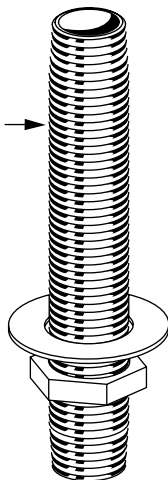

### CARE INSTRUCTIONS:

**DO: SIMPLY RINSE THE PRODUCT CLEAN WITH CLEAR WATER. DRY WITH A SOFT COTTON FLANNEL CLOTH.**

**DO NOT: CLEAN THE PRODUCT WITH SOAPS, ACID, POLISH, ABRASIVES, HARSH CLEANERS, OR A CLOTH WITH A COARSE SURFACE.**



HOTLINE FOR HELP  
For toll-free information and answers to your questions, call:  
1 (800) 442-1902

Weekdays  
8:00 to 7:00 p.m. Eastern Time

CANADA  
1-800-387-0369 (TORONTO 1-905-306-1093)



Product names listed herein are trademarks of American Standard Inc. © American Standard Inc. 2004

M968486

# American Standard

## AVAILABLE REPAIR PARTS

### 7274.515

-  AIR Index  
**M962314-0070A**
-  GAS Index  
**M962313-0070A**
-  VAC Index  
**M962315-0070A**

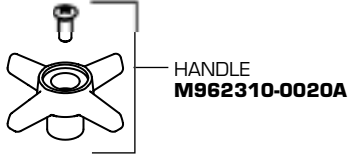



HANDLE  
**M962310-0020A**

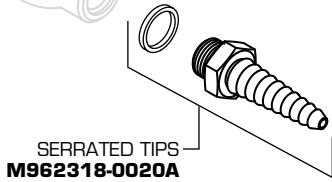
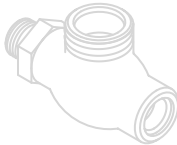

CARTRIDGE  
**M962336-0070A**



SERRATED TIPS  
**M962318-0020A**

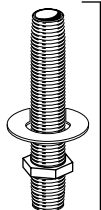
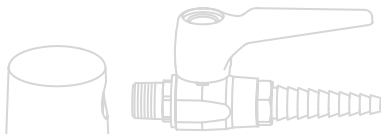

- AIR Index  **M962314-0070A**
- GAS Index  **M962313-0070A**
- VAC Index  **M962315-0070A**

### 7274.511 7274.511VR



**M962323-0070A**  
3/8" NPT X 4-3/4"  
INLET SHANK WITH  
LOCKNUT & WASHER



### 7274.521 7274.521VR

-  AIR Index  
**M962314-0070A**
-  GAS Index  
**M962313-0070A**
-  VAC Index  
**M962315-0070A**



**M962323-0070A**  
3/8" NPT X 4-3/4"  
INLET SHANK WITH  
LOCKNUT & WASHER

### 7274.525

-  AIR Index  
**M962314-0070A**
-  GAS Index  
**M962313-0070A**
-  VAC Index  
**M962315-0070A**

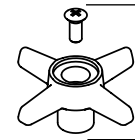
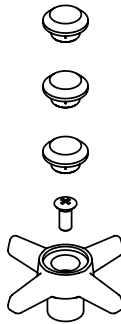

HANDLE  
**M962310-0020A**



CARTRIDGE  
**962336-0070A**

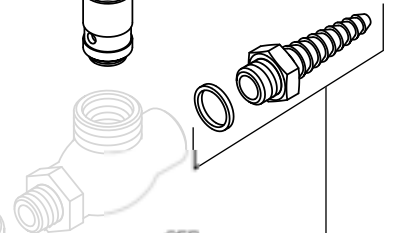

SERRATED TIPS  
**M962318-0020A**

