



# MODEL H0591 MICRO DIE GRINDER INSTRUCTION SHEET





<b>⚠ WARNING</b>	
	<b>EYE/EAR INJURY HAZARD!</b> Wear safety glasses and hearing protection during use of this tool!
	<b>INJURY HAZARD!</b> Always disconnect tool from air to prevent unexpected operation during service!
	<b>EXPLOSION HAZARD!</b> Never exceed 90 PSI! Only use cutters rated for 56,000 RPM or less!
	<b>RESPIRATORY HAZARD!</b> Grinding produces fine dust. Wear the appropriate protection during use!



Figure 1. Model H0591.

Micro die grinder **MUST** have 3-4 drops of oil directly dropped into the air fitting before each use as shown in **Figure 2**.

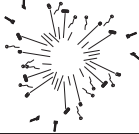
## Introduction

This Micro Die Grinder allows extreme flexibility in all kinds of environments. No-load speed is 56,000 RPM and requires 90 PSI of air pressure with 7 CFM of compressor capacity. Collet size is 1/8".

## Inventory

- A. Micro Die Grinder ..... 1
- B. 1/4" NPT Air Fitting..... 1
- C. Collet Wrenches ..... 2
- D. Oil Bottle..... 1

## Operation

Insert your 1/8" tool bit into the collet and tighten with the collet wrenches provided. Make sure the tool you use is rated for 56,000 RPM or less. Connect air fitting to your regulated air source.

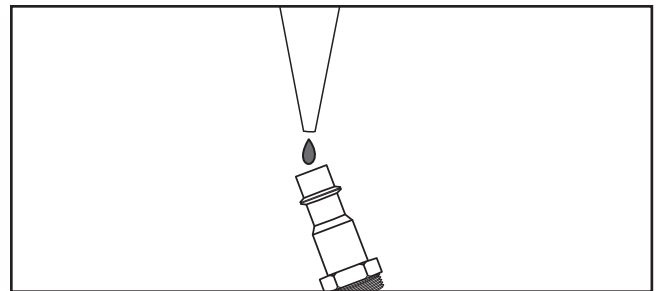

Figure 2. Lubricating directly into air fitting.

*If you need help with your new pneumatic tool, call our Tech Support at: (570) 546-9663.*

COPYRIGHT © MARCH, 2006 BY GRIZZLY INDUSTRIAL, INC.

**WARNING: NO PORTION OF THIS MANUAL MAY BE REPRODUCED IN ANY SHAPE OR FORM WITHOUT THE WRITTEN APPROVAL OF GRIZZLY INDUSTRIAL, INC.**

#PC8127 PRINTED IN TAIWAN

# H0591 Parts Breakdown and List

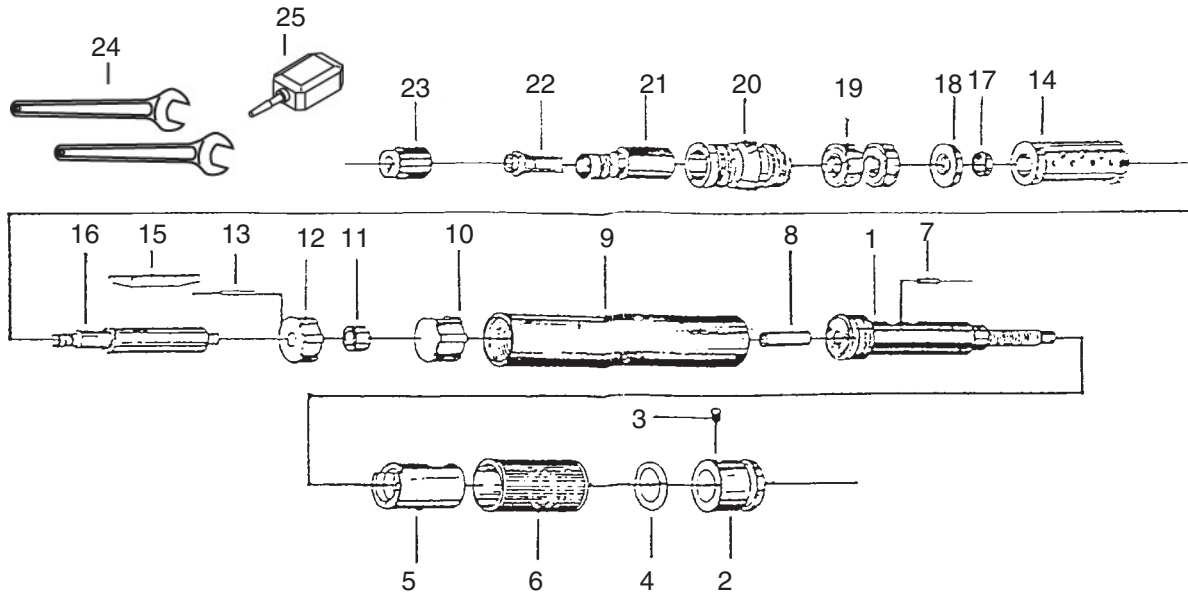

REF	PART #	DESCRIPTION
1	PH0591001	HOUSING PLUG
2	PH0591002	REAR END HOLDER
3	PH0591003	SCREW
4	PH0591004	O-RING
5	PH0591005	BUSHING
6	PH0591006	SLIDING KNOB
7	PH0591007	PIN
8	PH0591008	INTAKE STEEL TUBE
9	PH0591009	SLEEVE
10	PH0591010	INTAKE PLATE
11	PH0591011	BALL BEARING
12	PH0591012	BEARING PLATE
13	PH0591013	PIN

REF	PART #	DESCRIPTION
14	PH0591014	CYLINDER
15	PH0591015	ROTOR BLADES
16	PH0591016	ROTOR
17	PH0591017	LATERAL
18	PH0591018	SPACER
19	PH0591019	BALL BEARING
20	PH0591020	SPINDLE
21	PH0591021	FRONT COVER
22	PH0591022	COLLET
23	PH0591023	COLLET NUT
24	PH0591024	WRENCH SET
25	PH0591025	OIL BOTTLE