

PLATINUM FURNITURE

MODEL PFPL - *Digital TV Stand*

Assembly Instructions

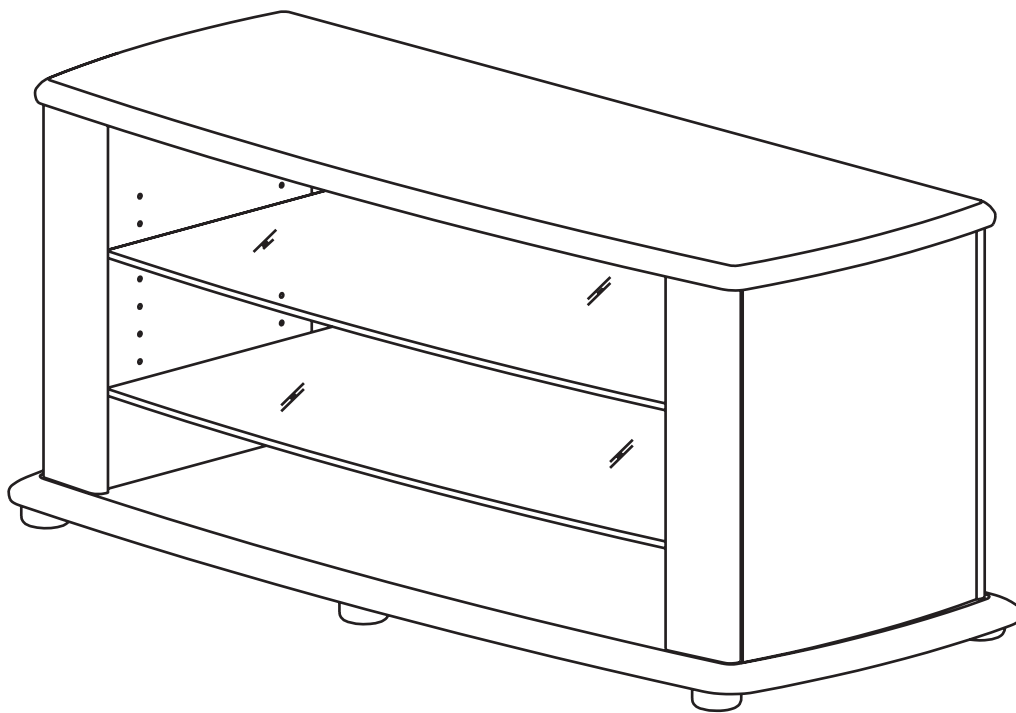

BUS5305

Congratulations and thank you for purchasing your new Sanus Platinum Furniture Product. If you have any questions regarding this or any other Sanus product, please contact our customer service department at (800)359-5520, or www.sanus.com. It is not necessary to contact the retailer with any questions or problems, as parts can be sent directly to you

Please follow these assembly instructions. This will save you time, make assembly easier and prevent possible damage to your new Digital TV Stand. Assistance may be required for some assembly procedures. Correct assembly is your responsibility.

We recommend that the unit is assembled on a soft surface such as carpet. Please record your serial number in the space provided below and retain this manual for future reference.

Serial No

This unit was manufactured using ISO 9000 certified systems. For improvement purposes, design and specifications are subject to change without notice.

SANUS | SYSTEMS

THE UNION OF FORM AND FUNCTION

UNPACK AND IDENTIFY PARTS

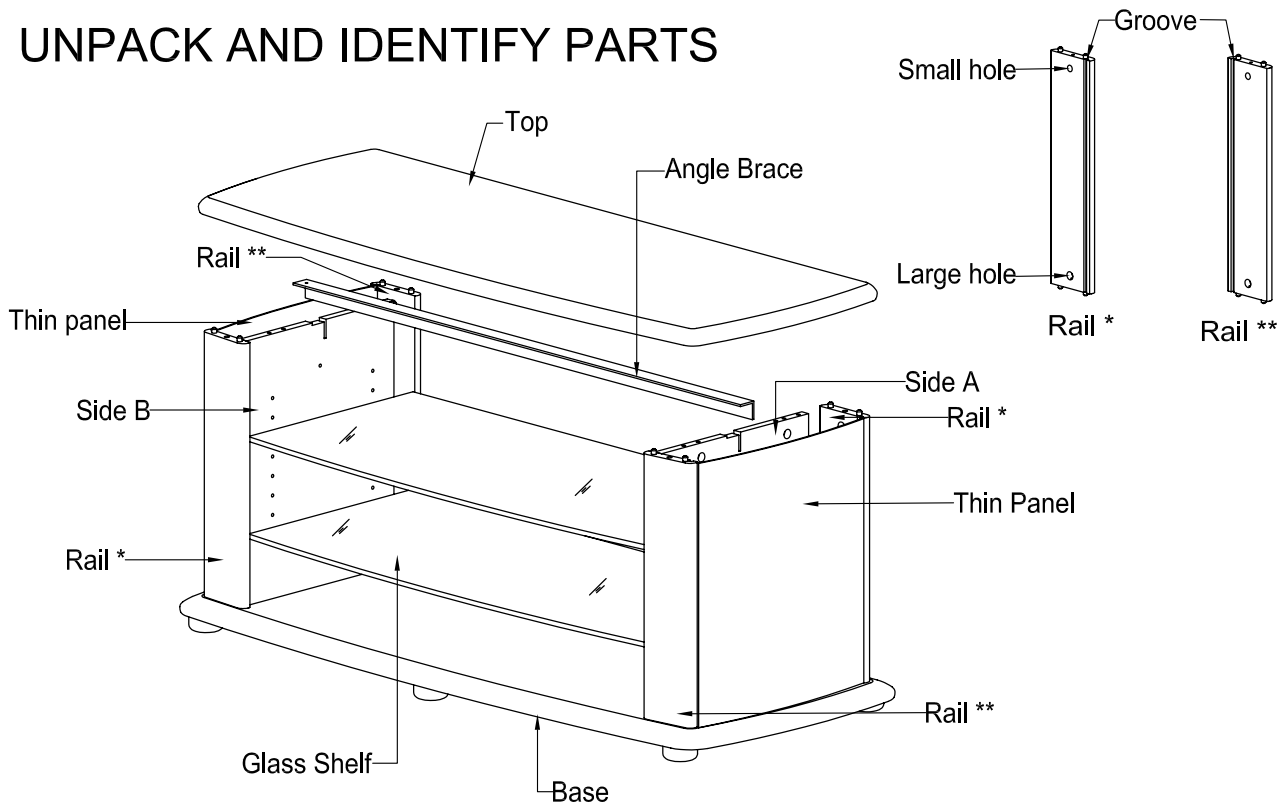

<u>PART DESCRIPTION:</u>	<u>QTY</u>	<u>PART NUMBER</u>
		Stipple silver
Top	1	M19965A1SS
Base	1	M19966A1SS
Side A	1	M19967A1SS
Side B	1	M19968A1SS
Rail *	2	M19969A1SS
Rail **	2	M19970A1SS
Thin panel	2	M19971A1SS
Glass Shelf	2	M19972A1PO
Angle Brace	1	M19111A1PO
Glide	6	P815049
Hardware Pack	1	MH1139A0

TOOLS REQUIRED:

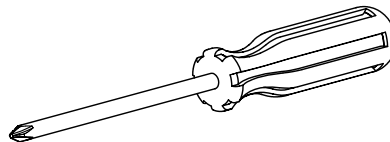

PHILLIPS No.2 SCREWDRIVER

CUSTOMER SERVICE INFORMATION

IN THE UNLIKELY EVENT OF PARTS BEING FAULTY OR MISSING, CHECK PACKAGING. REPLACEMENT PARTS CAN BE OBTAINED BY CALLING THE TOLL FREE NUMBER WITHIN 14 DAYS OF PURCHASE.

TOLL-FREE NUMBER - 1800-359-5520 (USA ONLY)

THE FOLLOWING INFORMATION MUST BE SUPPLIED IN FULL:

1. YOUR NAME, ADDRESS AND TELEPHONE NUMBER.
2. PRODUCT MODEL NAME/NUMBER AND COLOR.
3. DESCRIPTION, PART NUMBER AND QUANTITY OF REQUIRED PARTS.
4. PURCHASE DETAILS: -STORE THE UNIT WAS PURCHASED FROM.
-DATE OF PURCHASE.
5. SERIAL NUMBER OF THE UNIT PURCHASED.
(LOCATED ON REAR OF UNIT)

Hardware Contents:

CAUTION

There are many small components used in the construction of this unit.
These loose items should be kept away from young children while
assembling your unit.

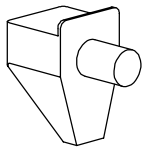

Shelf Pin
P840048 x 8



P860121 x 1

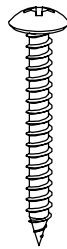

P860035 x 6



Barrel nut
P840050 x 8

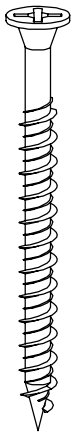

P860015 x 8

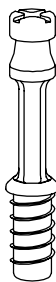

Connector rod
P820016T x 8

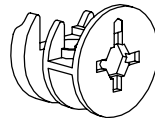

Cam
P820015T x 8



Wooden dowel
P800201 x 8

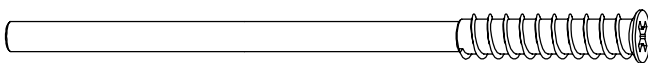

P816145 x 4

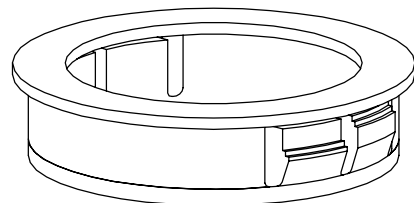

Cable Ducts
P840170 x 2

STEP 1

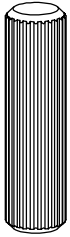

Wooden Dowels x 8

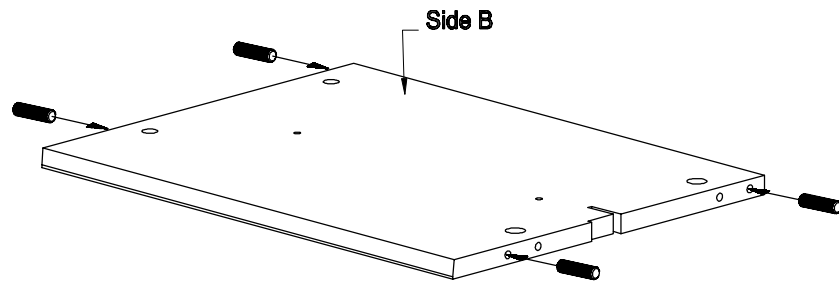
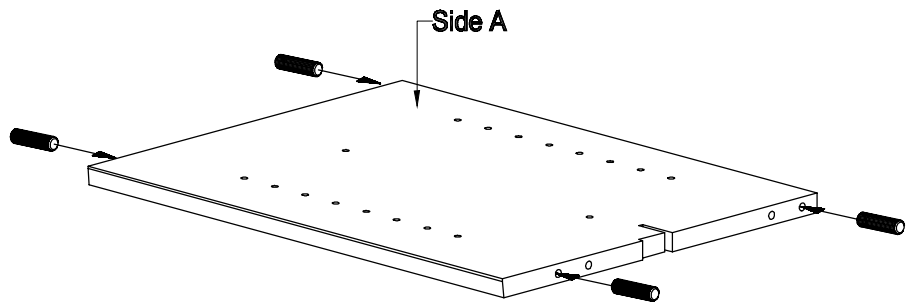

Insert wooden dowels into sides as shown.

STEP 2

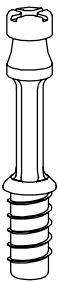

x 8

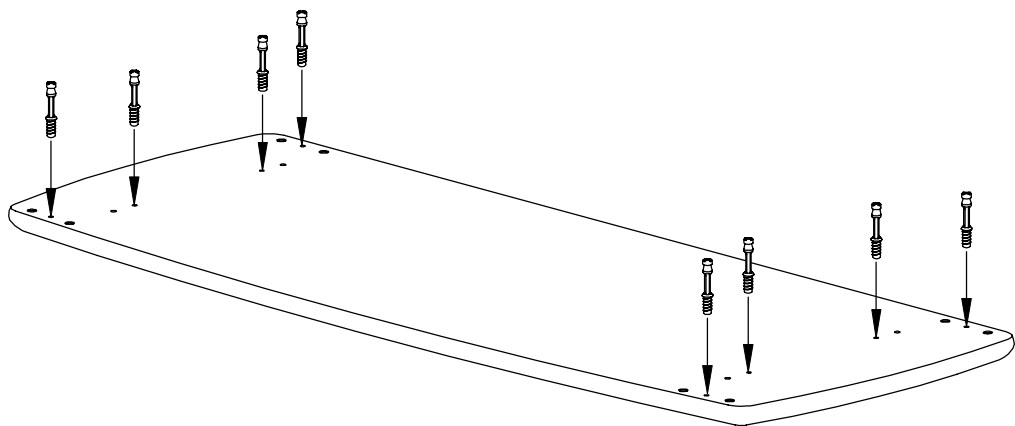

1. Fasten 8 Connector Rods into small holes in Top as shown.

STEP 3

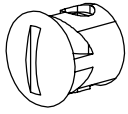

Black Barrel nut x 4

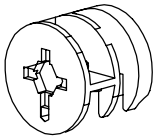

Cam x 4

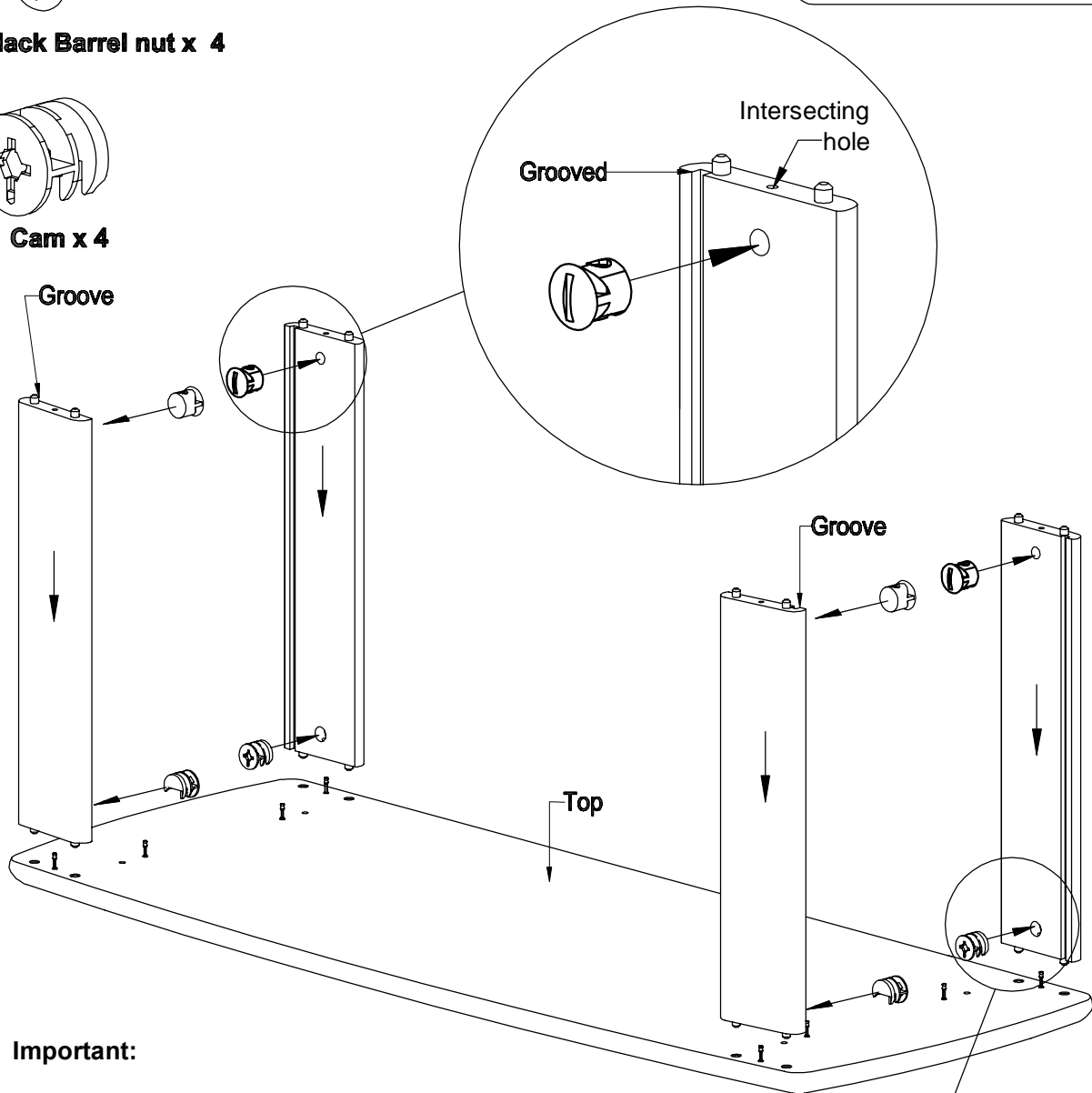
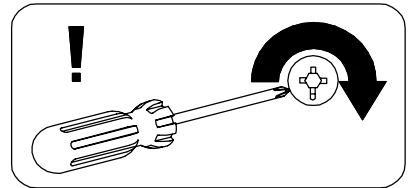

Important:

*When fitting the rails onto the top, ensure that the grooved part of the rails are closest to the side edges of the top.

* The larger holes (cam holes) in the rails must always be closest to the Top.

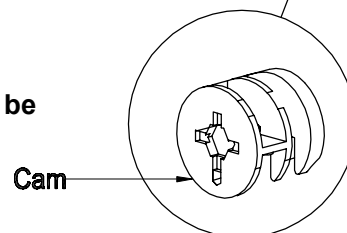

1. Insert black Barrel Nuts into smaller holes in Rails, ensuring slot in cap is aligned to intersecting hole.
2. Insert silver Cams into larger holes in Rails, ensuring that arrow on Cam points towards intersecting hole.
3. Press fit Rails to Top as shown.

IMPORTANT

The new Sanus stand has been designed to complement TVs with curved and flat bases. The stand can be assembled with either curved front top & base or flat front top & base facing forward.

Most steps in the assembly instructions are the same for both designs. However, steps 4A,5A,6A and 7A are for the curved front stand option whereas steps 4B,5B,6B and 7B are for the flat front stand option.

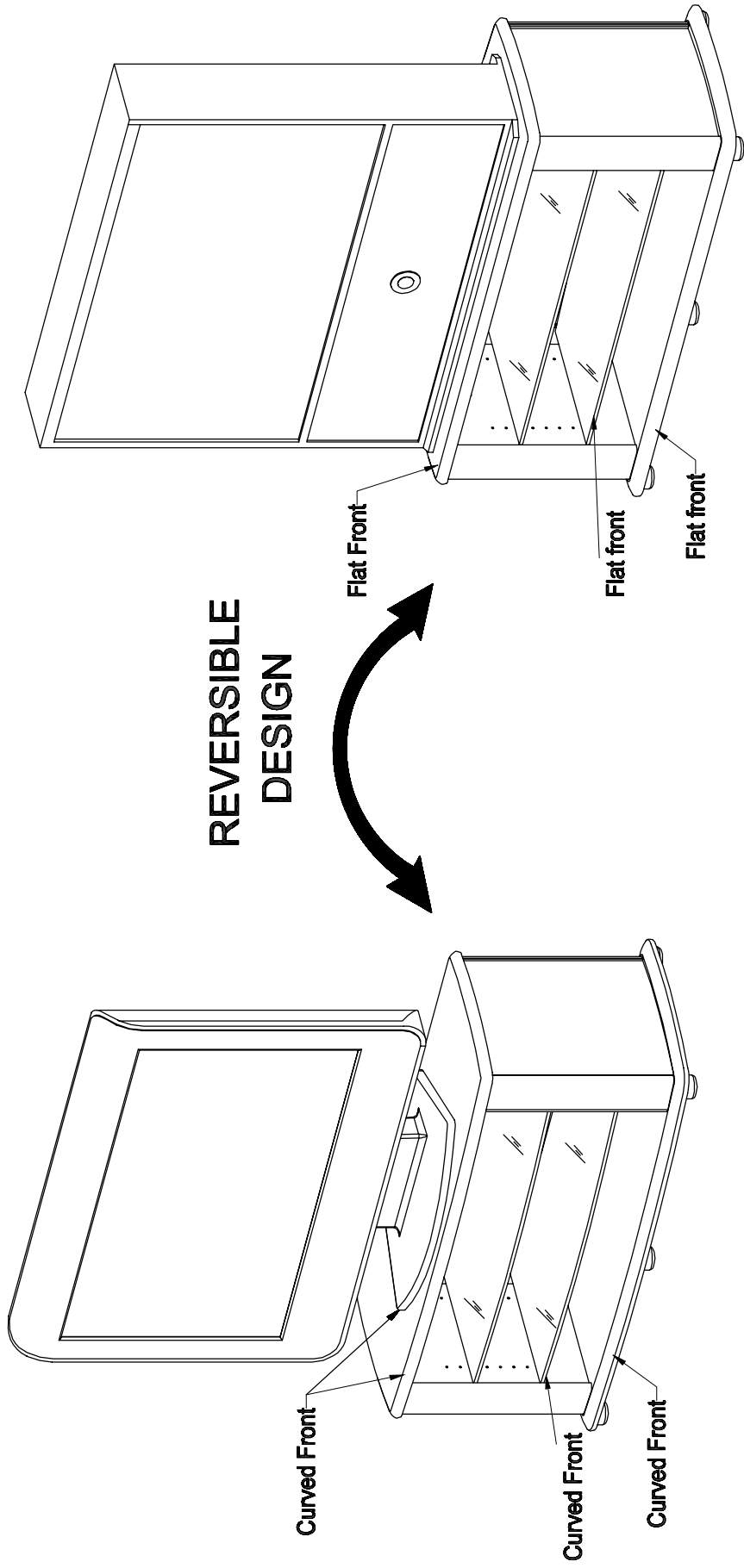

Sanus stand with curved front design complementing TVs with curved base.

Sanus stand with flat front design complementing TVs with flat base.

ASSEMBLING THE STAND WITH CURVED FRONT.

STEP 4 A

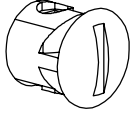

Black Barrel nut x 4

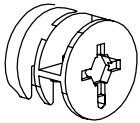

Cam x 4

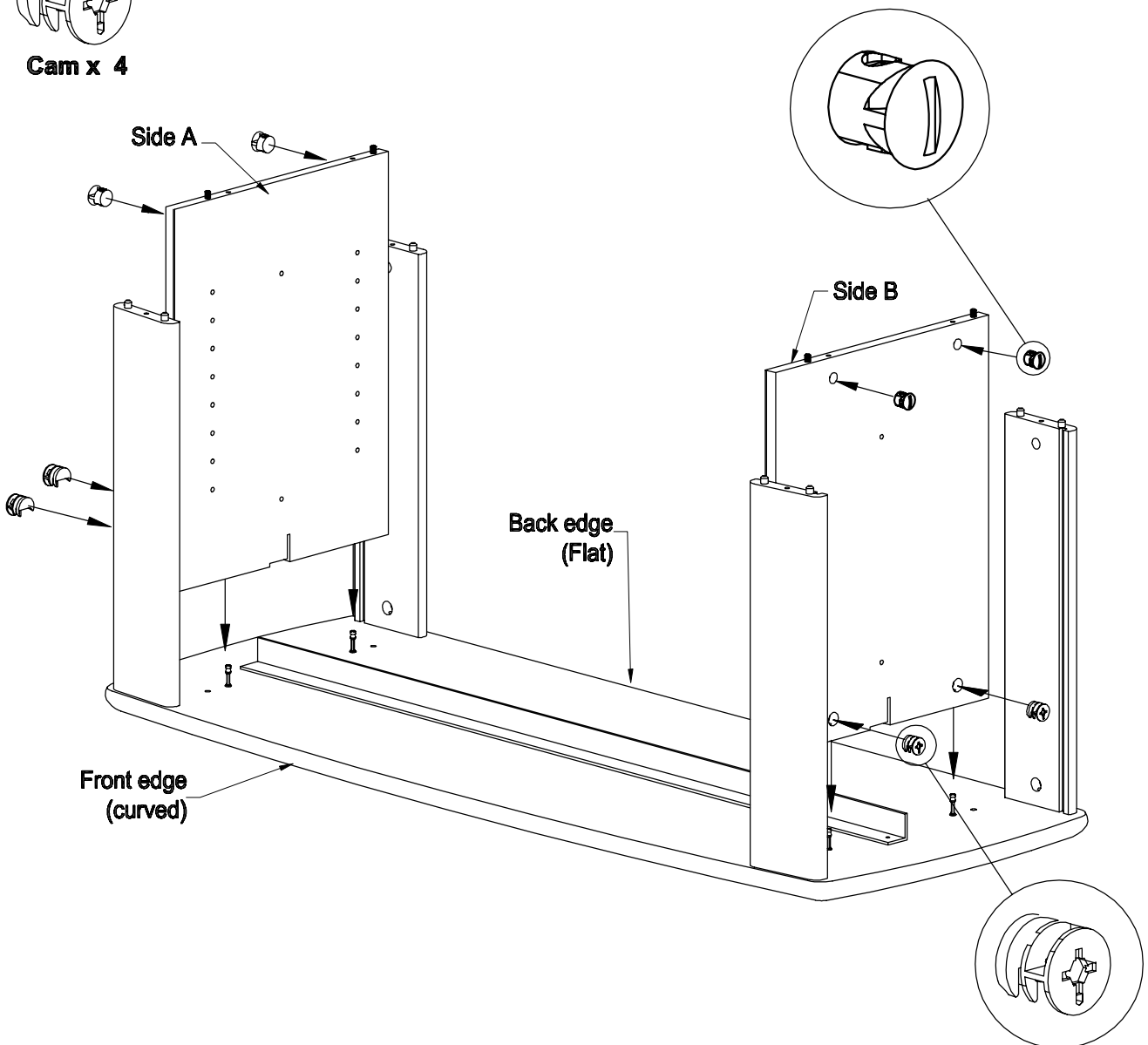
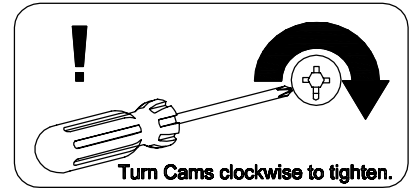

1. Insert black Barrel Nuts into holes in Sides, ensuring slot in cap is aligned to intersecting hole.
2. Insert silver Cams into large holes in sides, ensuring that arrow on Cam points towards Top panel.
3. Press fit Side's to Top, ensuring Angle Brace is in slots in Sides (ensuring orientation of Metal Brace as shown).

STEP 5 A

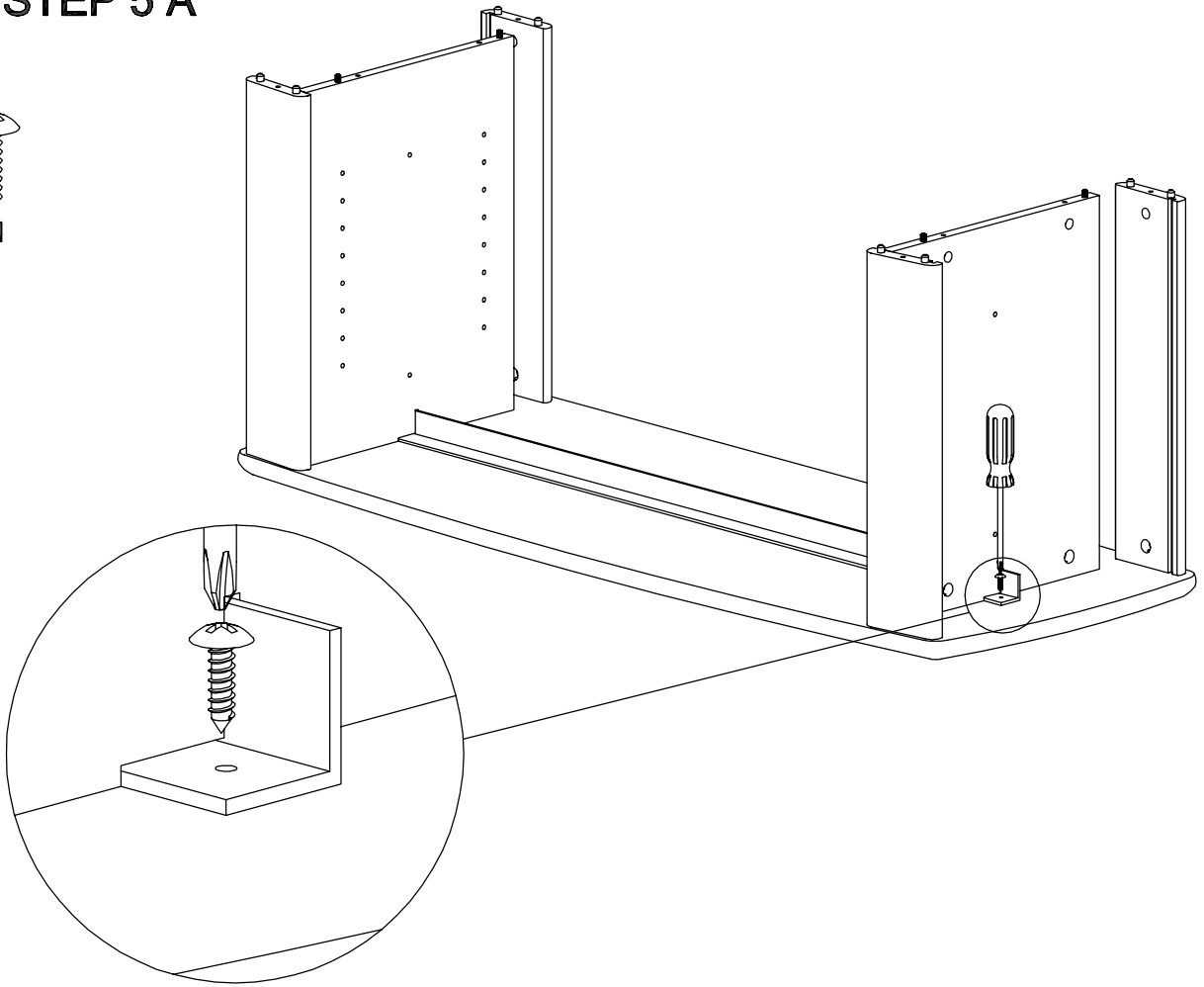

1. Secure Angle Brace to Top as shown above.

STEP 6 A

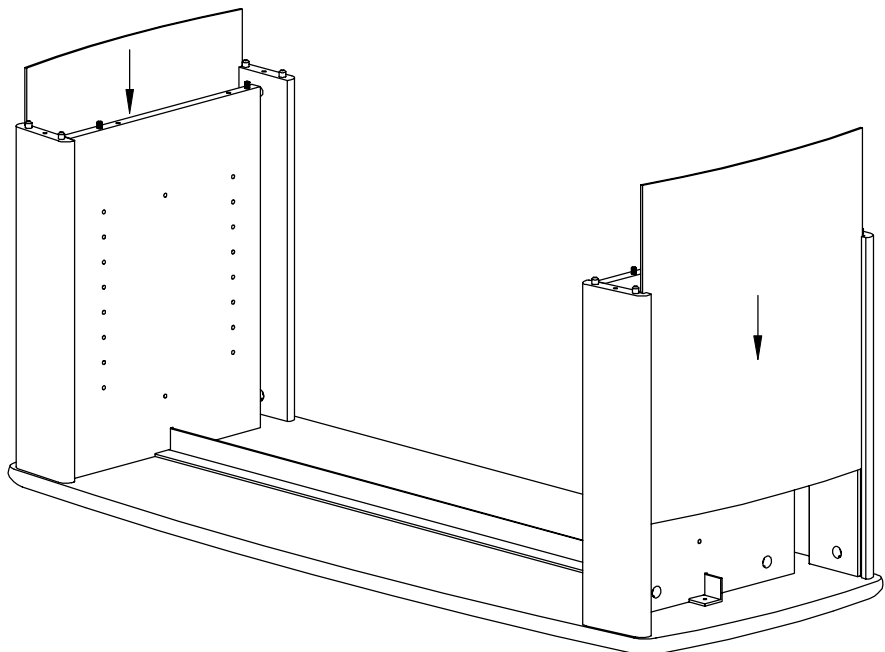

1. Slide Thin Panels down slots in Rails, ensuring Silver surfaces face out.

STEP 7 A

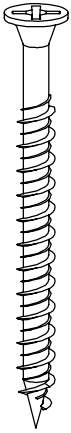

Locking screw x8

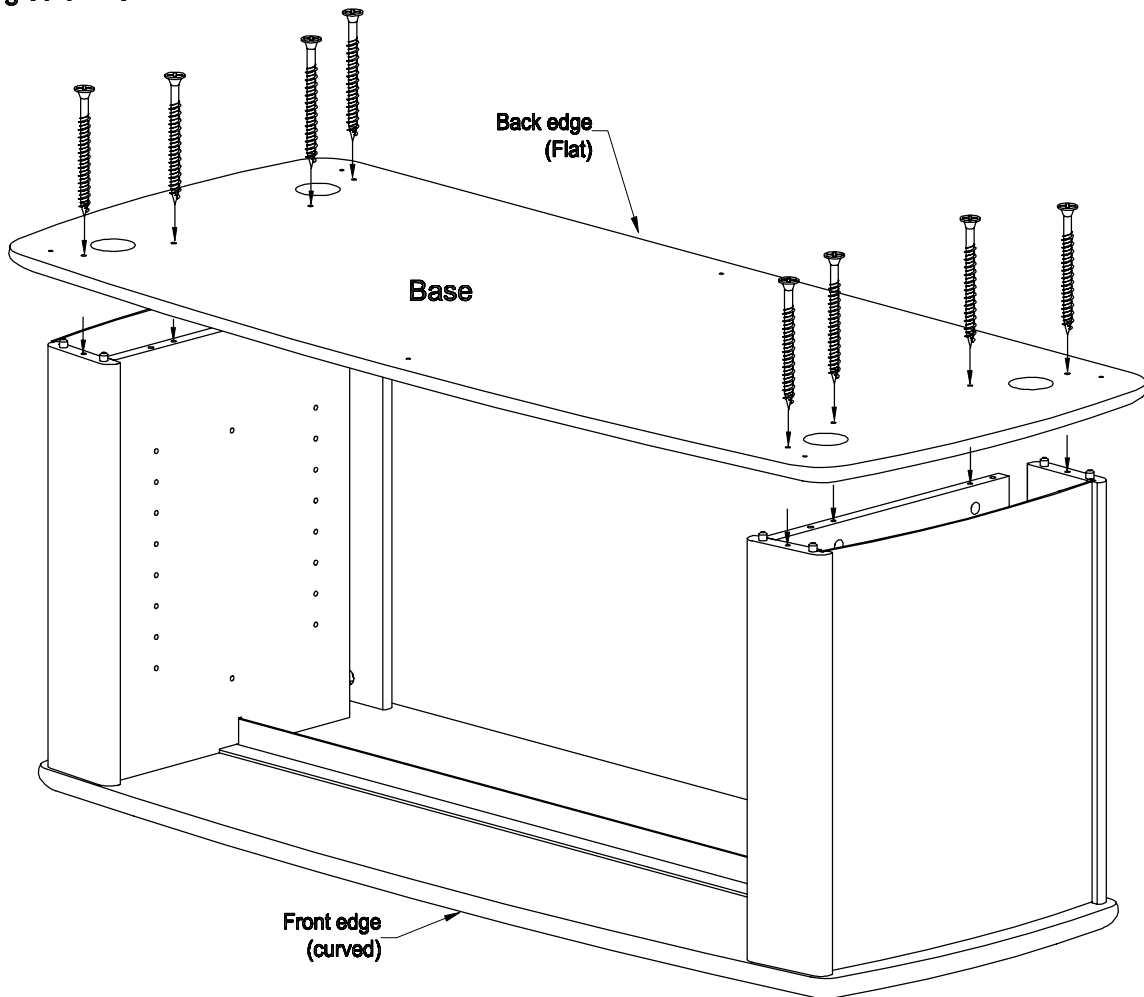

1. With assistance align Base onto Dowels in Sides & Rails & then press fit.
2. Fasten large Locking screws through Base into Sides & Rails (*Screw heads should be flush with surface*).

ASSEMBLING THE STAND WITH FLAT FRONT.

STEP 4 B

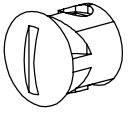

Black Barrel nut x 4

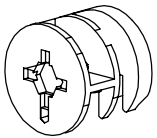
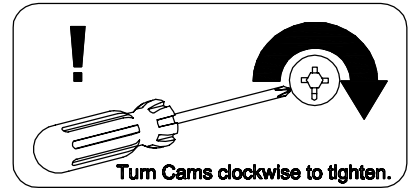

Cam x 4

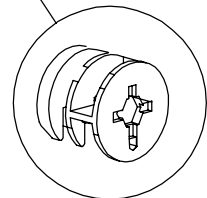
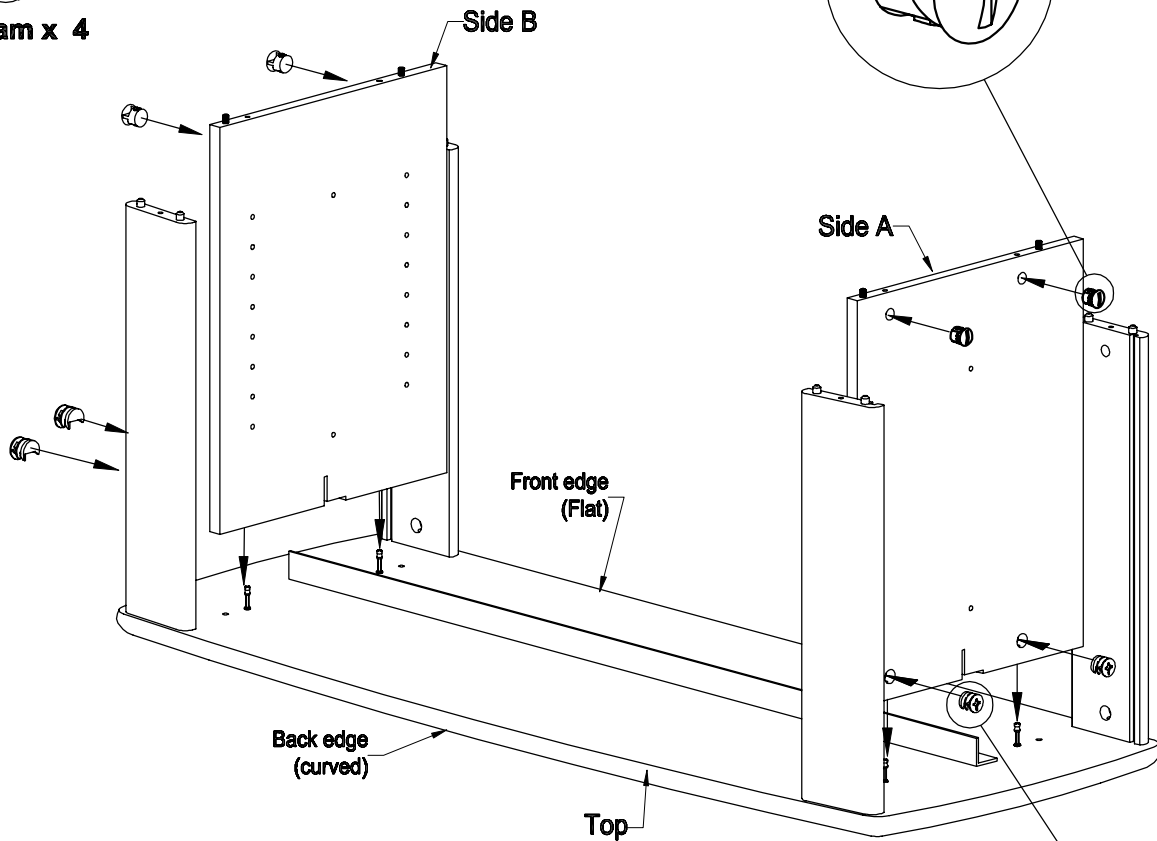

1. Insert black Barrel Nuts into holes in Sides, ensuring slot in cap is aligned to intersecting hole.
2. Insert silver Cams into large holes in sides, ensuring that arrow on Cam points towards Top panel.
3. Press fit Side's to Top, ensuring Angle Brace is in slots in Sides (ensuring orientation of Metal Brace as shown).

STEP 5 B

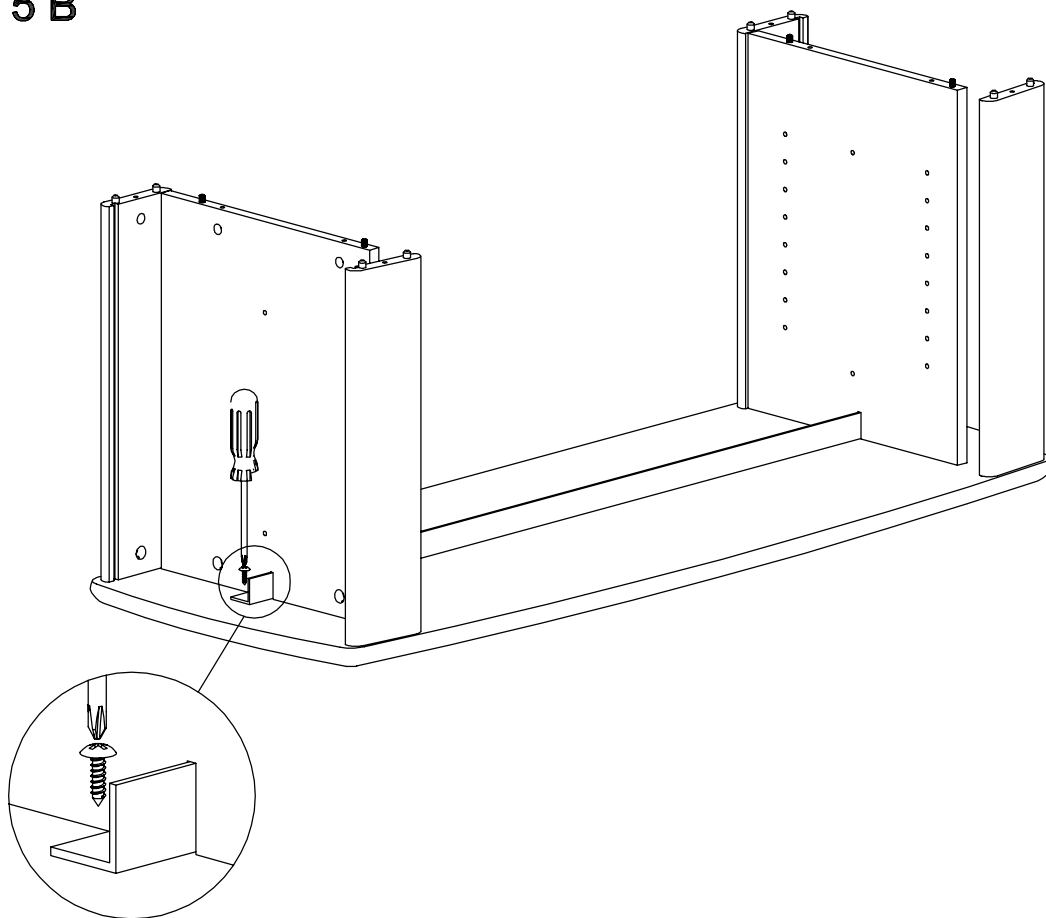

1. Secure Angle brace to Top as shown above.

STEP 6 B

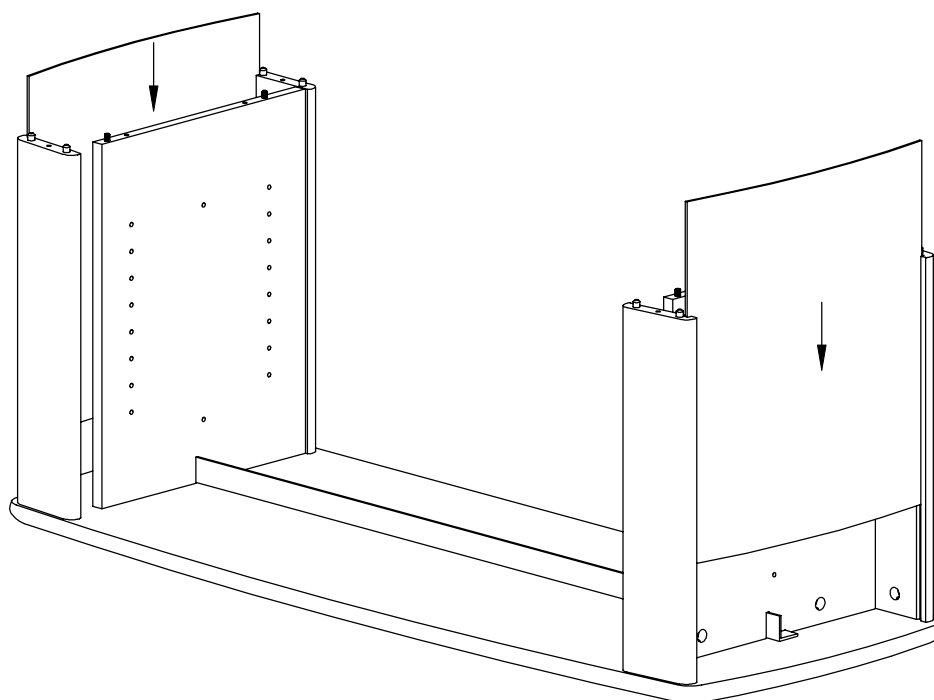

1. Slide Thin Panels down slots in Rails, ensuring Silver surfaces face out.

STEP 7 B

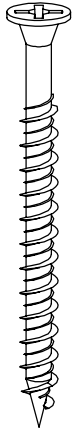

Locking screw x8

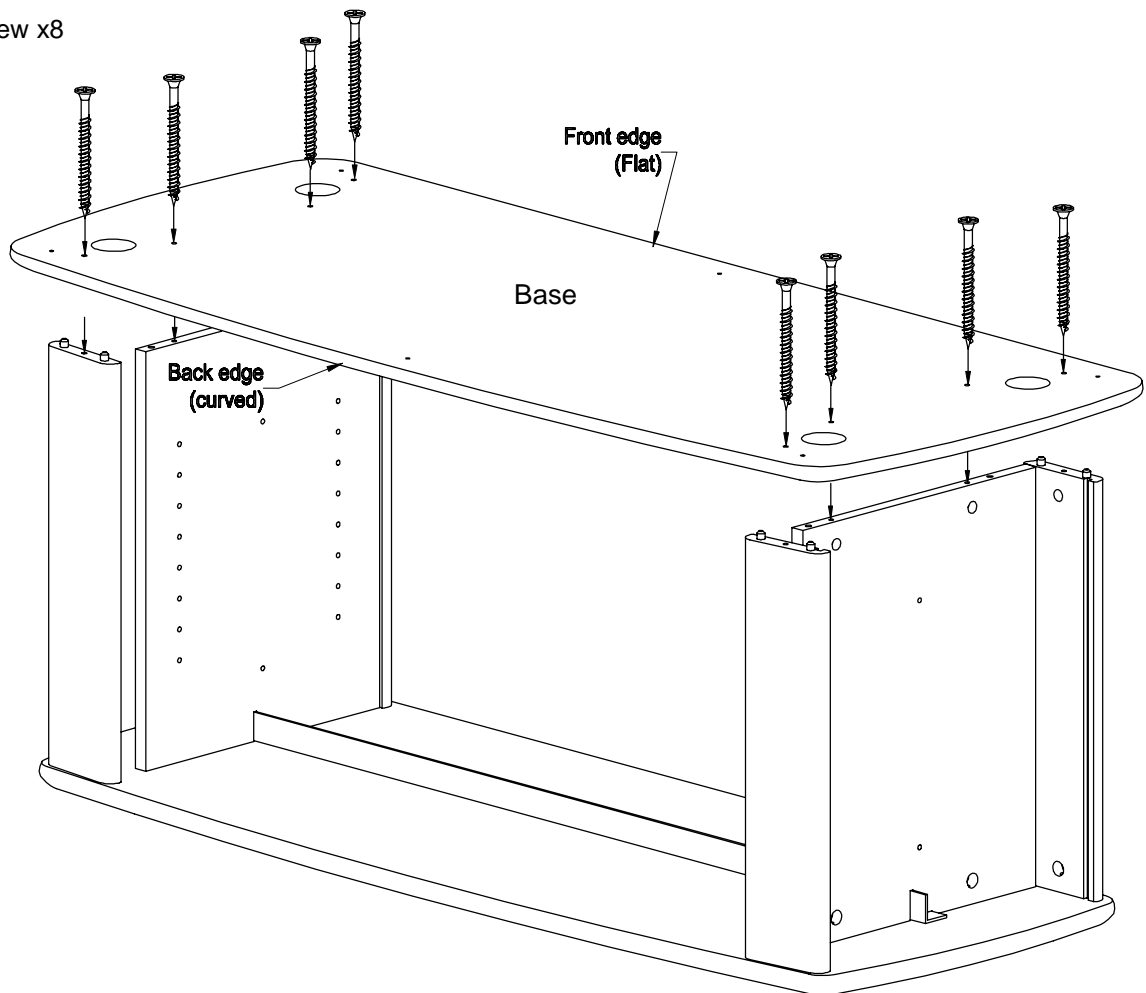

1. With assistance align Base onto Dowels in Sides & Rails & then press fit.
2. Fasten large Locking screws through Base into Sides & Rails (*Screw heads should be flush with surface*).

Following steps apply to both flat and curved front designs.

STEP 8

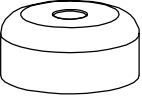

Glide x6



Screw x6

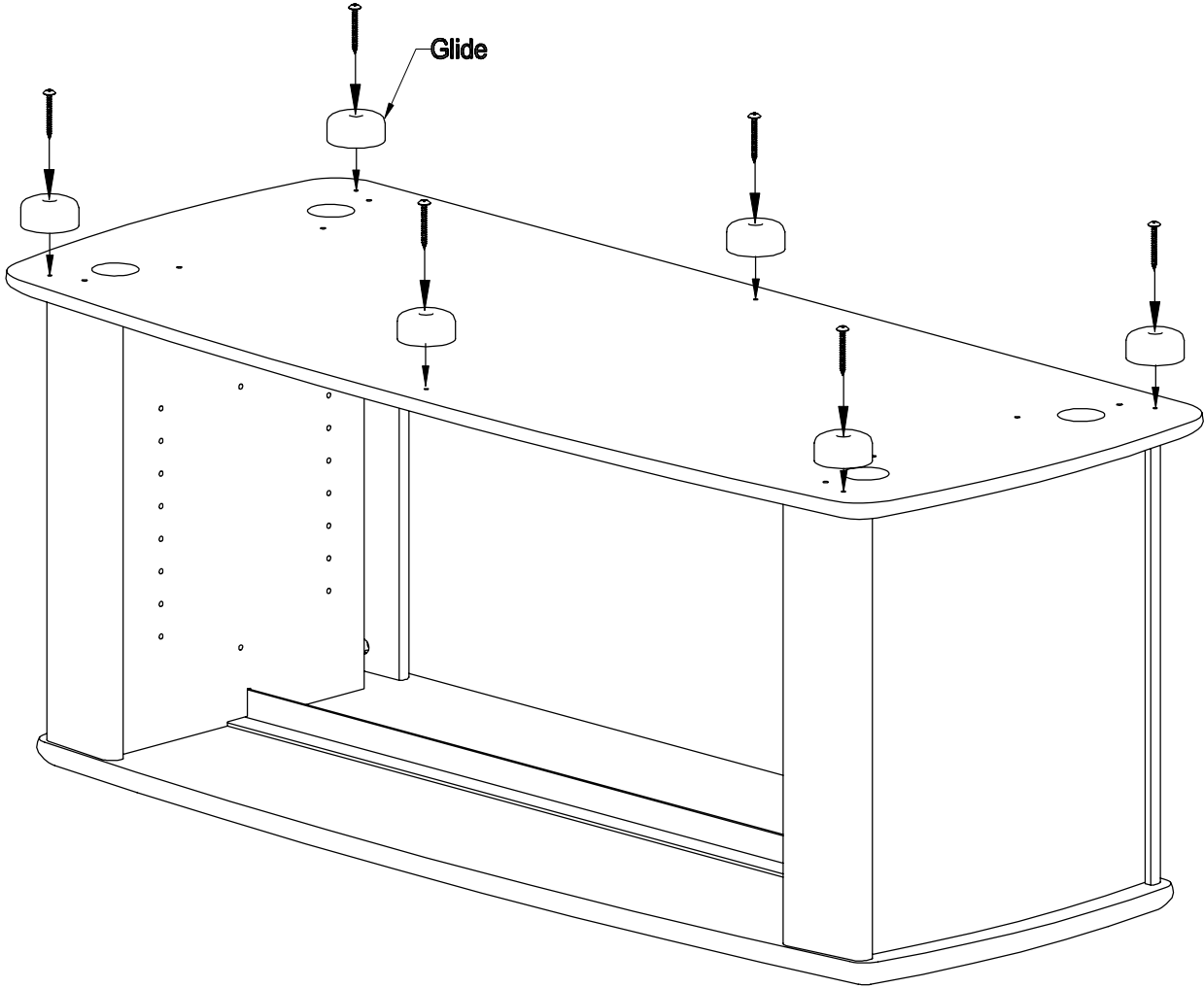

1. Fasten the glides to the base as shown.

STEP 9

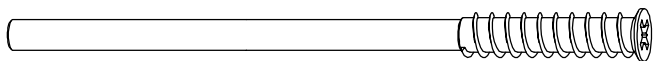

Adjusting screw x 4

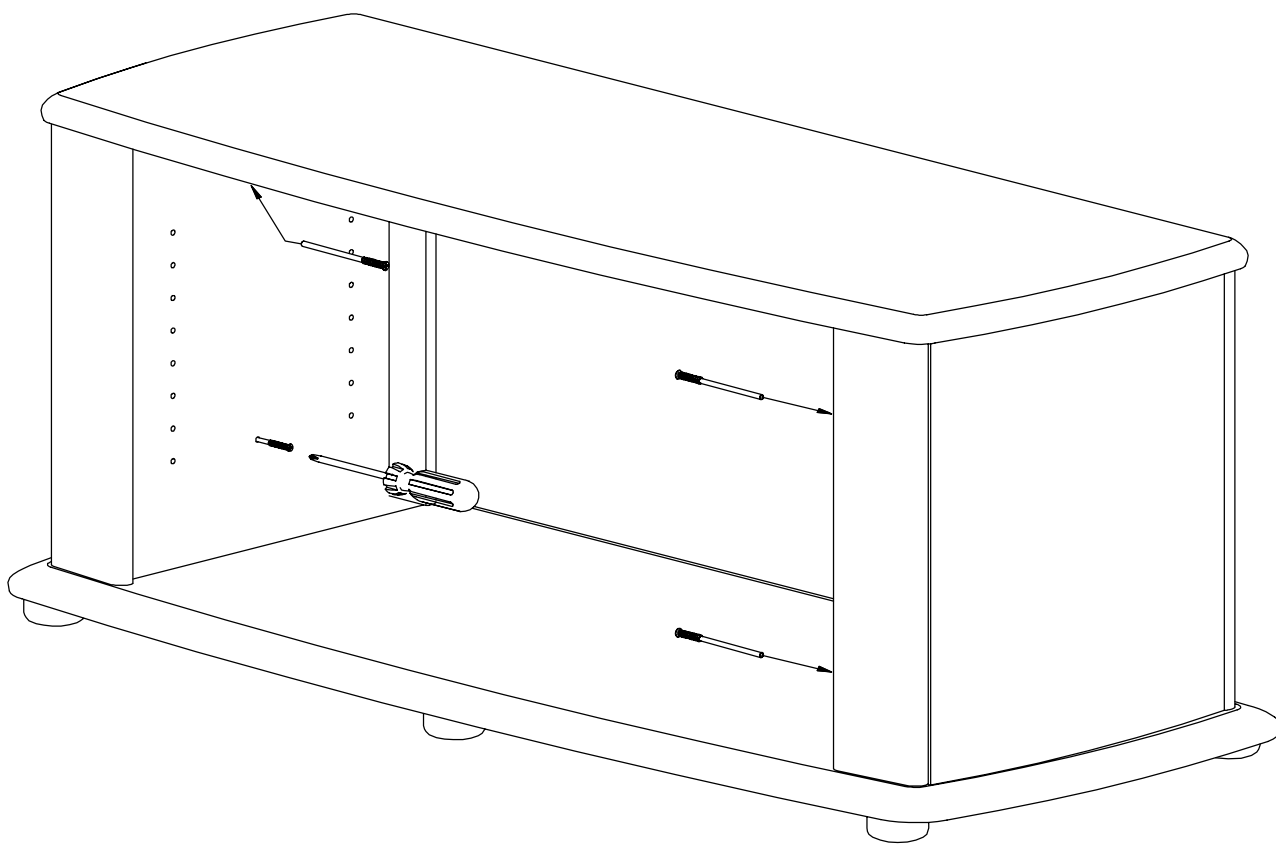

1. Turn unit over carefully.
2. Screw each Adjusting screw into Side by half of it's visible threaded length, then once this is done, tighten all 4 Adjusting screws fully into Side.

STEP 10



Shelf Pin x8

Curved edge of the glass shelves must be placed at front for curved front design.



Front edge (curved)

Flat edge of the glass shelves must be placed at front for the flat front design.



Front edge (flat)

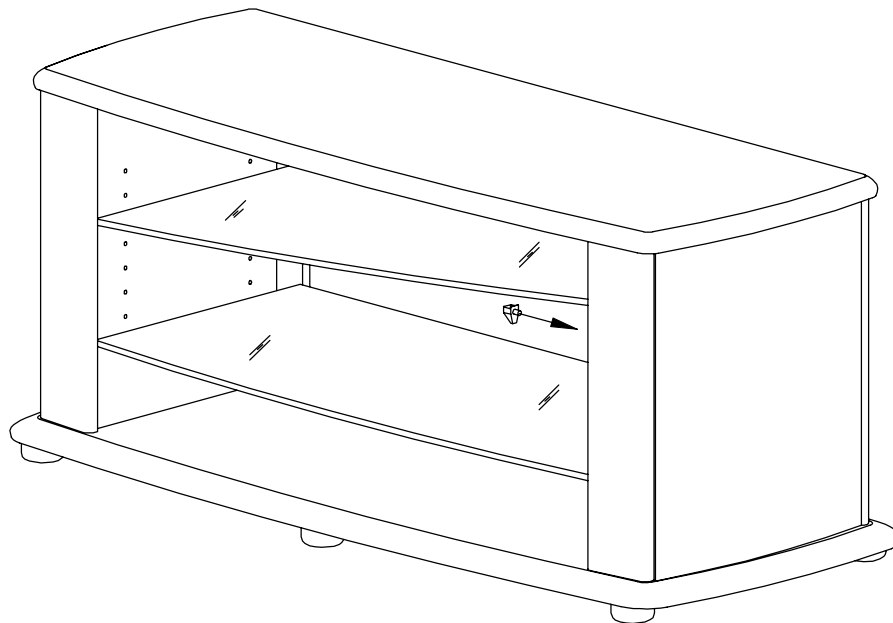
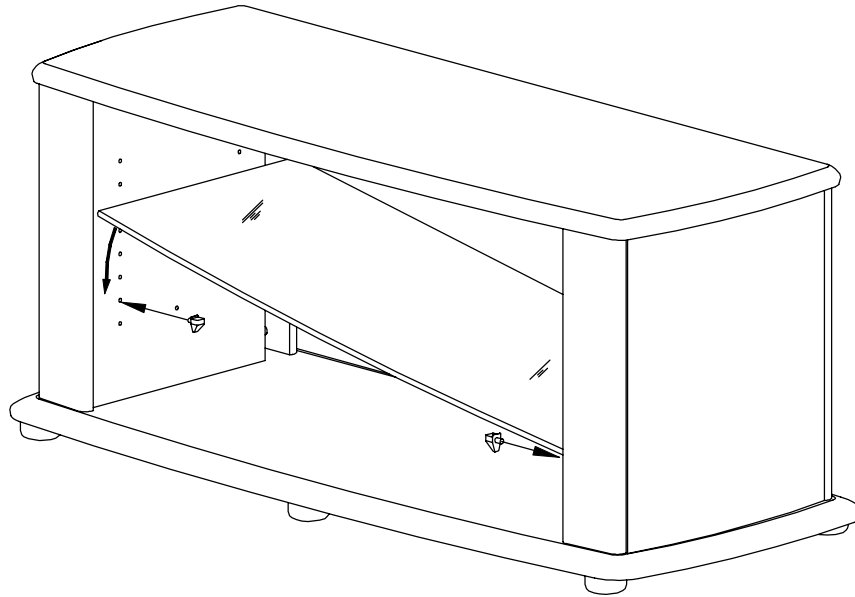

1. Insert Shelf Pins into holes at the lower positions of both the Sides (as illustrated above).
2. Tilt and slide Glass Shelf between Rails (ensuring frosted side down) and place on top of Shelf Pins.
3. Insert Shelf Pins into holes at the upper positions of one Side only.
4. Tilt and slide the second Glass Shelf between Side Rails. While holding one end of the shelf on pins on one side insert remaining Shelf Pins into other side beneath Glass, then lower the shelf on top of the pins.

STEP 11

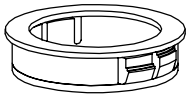

Cable Duct x2

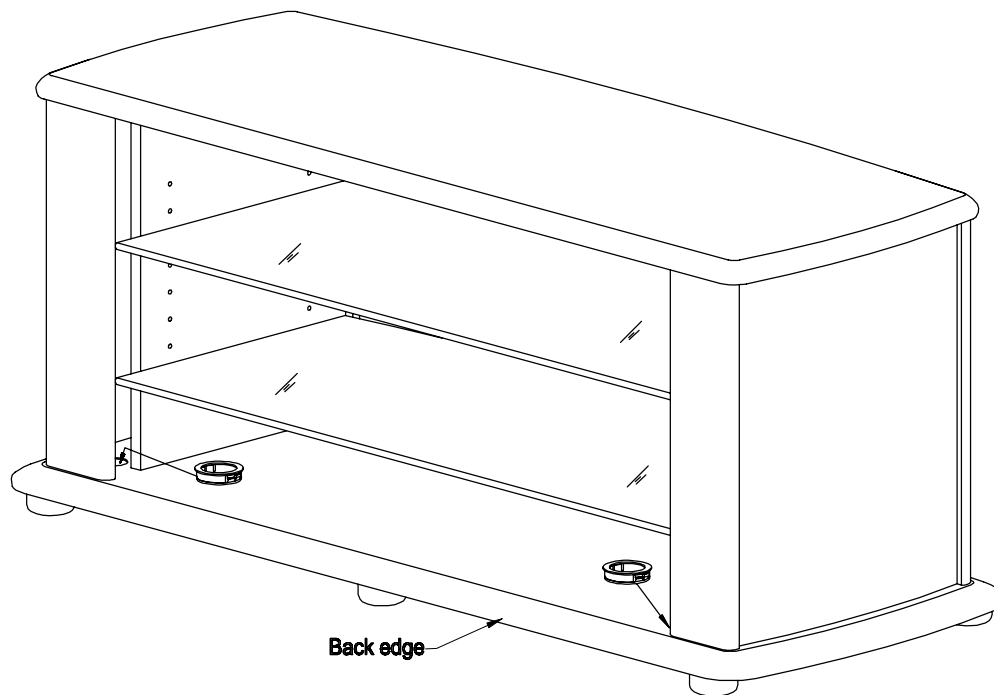

1. Press fit 2 Cable Ducts into large holes in the Base.
2. You have now completed the assembly of your new Digital TV stand.

NOTE: We recommend that all contents stored in or on this item of furniture be removed before shifting it. The manufacturers will not be held liable for damage caused when furniture is shifted without first removing its contents. If furniture is shifted we recommend that it is lifted not dragged.