

MasterColor® CDM Elite MW 210 Watt 4200K T9 (Clear) Lamp

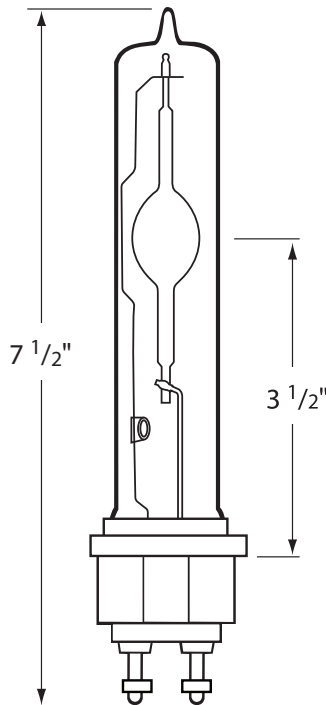

Ordering Information

Ordering Code	CDM Elite MW
	210/T9/942/U/E
ANSI Designation	C183/E
Product Number	220632
Description	Ceramic Metal Halide
Package Quantity	12

Physical Characteristics

Bulb Size	T9
Bulb Finish	Clear
Base	PGZ18
Max. Overall Length (MOL)	7 1/2" (188mm)
Light Center Length (LCL)	3 1/2" (90mm)
Arc Tube Material	Ceramic (PCA)
Max. Permissible Bulb Temp.	650°C (1200°F)
Max. Permissible Base Temp.	320°C (600°F)
Max. Bulb to Base Eccentricity	3°
Max. Arc Tube to Base Eccentricity	3°

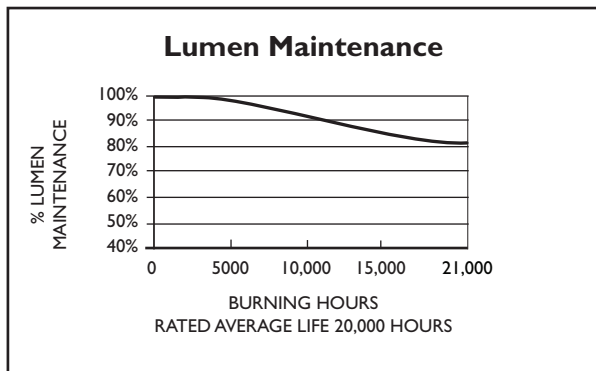

Operating Characteristics (Photometric)

Rated Initial Lumens ¹	23,000
Mean Lumens, Approx. ²	21,200
Rated Average Life, Hours ³	20,000
Correlated Color Temp. (CCT)	4200K
CIE Chromaticity Approx.	x-.433, y-.399
Color Rendering Index (CRI)	90
R9	>80
Efficacy (lpw)	110

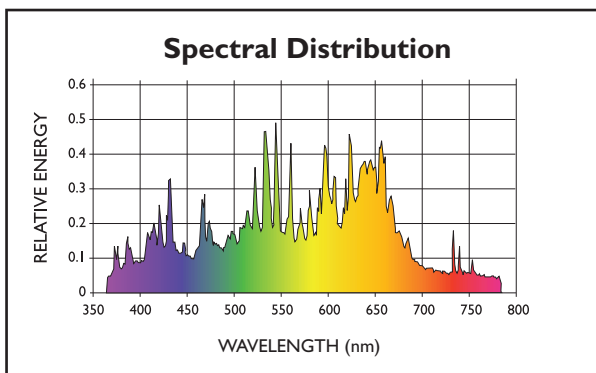

Operating Position

Universal — Enclosed Luminaires Only

For horizontal operation, the frame wire above the arc tube has optimal performance.

PHILIPS

MasterColor® CDM Elite MW 210 Watt 4200K T9 (Clear) Lamp

Electrical Data (Subject to change without notice)

Lamp Watts (Nominal)	210
Lamp Operating Voltage (rms) (Nominal) ⁴	100
Initial Lamp Voltage Range (rms) ⁵	90V–115V
Lamp Operating Current (Amps) (rms) (Nominal)	2.1
Warm-up Time to 80% of Output	<3 Minutes
Re-strike Time for Hot Lamp	10 Minutes
Ballast Type	Electronic, ANSI C183/E
Ballast Open Circuit Voltage (Minimum)	260V
Ignition Burst Height (Maximum)	4KV
Minimum Operating Temperature	-20°C

- 1) Measured at 100 hrs of life in vertical position.
- 2) Approximate lumen output at 40% of lamps rated average life.
- 3) Rated average life is obtained at 50% survival rate.
- 4) Measured at rated lamp watts on a linear reactor or electronic ballast. LPW does not include ballast losses.
- 5) Measured with the lamp operating at rated watts.

Warnings, Cautions and Operating Instructions

R“**WARNING:** These lamps can cause serious skin burn and eye inflammation from short wave ultra-violet radiation if outer envelope of the lamp is broken or punctured. Do not use where people will remain for more than a few minutes unless adequate shielding or other safety precautions are used. Certain lamps that will automatically extinguish when the outer envelope is broken or punctured are commercially available.” This lamp complies with FDA radiation performance standard 21 CFR subchapter J. (USA: 21CFR 1040.30 Canada:SOR/DORS/80-381)

If the outer bulb is broken or punctured, turn off at once and replace the lamp to avoid possible injury from hazardous short wave ultraviolet radiation. Do not scratch the outer bulb or subject it to pressure as this could cause the outer bulb to crack or shatter. A partial vacuum in the outer bulb may cause glass to fly if the envelope is struck.

WARNING: The arc-tube of metal halide lamps are designed to operate under high pressure and at temperatures up to 1000°C and can unexpectedly rupture due to internal or external factors such as a ballast failure or misapplication. If the arc-tube ruptures for any reason, the outer bulb may break and pieces of extremely hot glass might be discharged into the surrounding environment. If such a rupture were to happen, **THERE IS A RISK OF PERSONAL INJURY, PROPERTY DAMAGE, BURNS AND FIRE.**

Certain lamps that will retain all the glass particles should inner arc-tube rupture occur are commercially available from Philips Lighting Company.

RELAMP FIXTURES AT OR BEFORE THE END OF RATED LIFE.
Allowing lamps to operate until they fail is not advised and may increase the possibility of inner arc tube rupture. This lamp contains an arc tube with a filling gas containing less than 25 nCi of Kr-85 and is distributed by Philips Lighting Company, a division of Philips Electronics North American Corporation.

CAUTION: TO REDUCE THE RISK OF PERSONAL INJURY, PROPERTY DAMAGE, BURNS AND FIRE RESULTING FROM AN ARC-TUBE RUPTURE THE FOLLOWING LAMP OPERATING INSTRUCTIONS MUST BE FOLLOWED:

Lamp Operating Instructions:

1. Relamp fixtures at or before the end of rated life. Allowing lamps to operate until they fail is not advised and may increase the possibility of inner arc tube rupture.
2. Use only in an enclosed fixture capable of withstanding particles of glass having temperatures up to 1000°C.
3. Before lamp installation/replacement, shut power off and allow lamp and fixture to cool to avoid electrical shock and potential burn hazards.
4. Use only auxiliary equipment meeting Philips and/or ANSI standards. Use within voltage limits recommended by ballast manufacturer.
 - A. Operate lamp only within specified limits of operation.
 - B. For total supply load refer to ballast manufacturers electrical data.
 - C. All Pulse Start lamps require a socket rated to withstand a 4,000 volt pulse
5. Periodically inspect the outer envelope. Replace any lamps that show scratches, cracks or damage.
6. If a lamp bulb support is used, be sure to insulate the support electrically to avoid possible decomposition of the bulb glass.
7. Protect lamp base, socket and wiring against moisture, corrosive atmospheres and excessive heat.
8. Time should be allowed for lamps to stabilize in color when turned on for the first time. This may require several hours of operation, with more than one start. Lamp color is also subject to change under conditions of excess vibration or shock, and color appearance may vary between individual lamps.
9. Lamps may require 10 minutes to re-light if there is a power interruption.
10. Take care in handling and disposing of lamps. If an arc tube is broken, avoid skin contact with any of the contents or fragments.
11. Use this lamp only in fixtures that contain a Pulse Start metal halide ballast and are specifically designed for use with Pulse Start metal halide lamps.

