

READ AND UNDERSTAND THESE INSTRUCTIONS BEFORE INSTALLING FIXTURE

This fixture is intended for installation in accordance with the National Code and local regulations. To assure full compliance with local codes and regulations, check with your local electrical inspector before installation. To prevent electrical shock, turn off electricity at fuse box before proceeding. **Retain these instructions for maintenance reference.**

SH20300

INSTRUCTIONS FOR WIRING OF AGILI-T FIXTURES

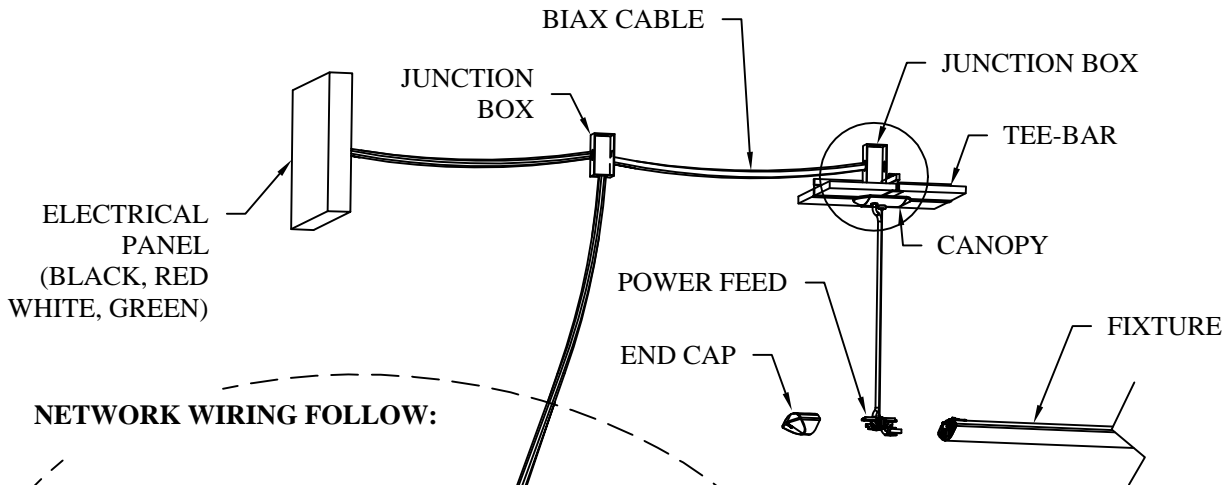

NETWORK WIRING FOLLOW:

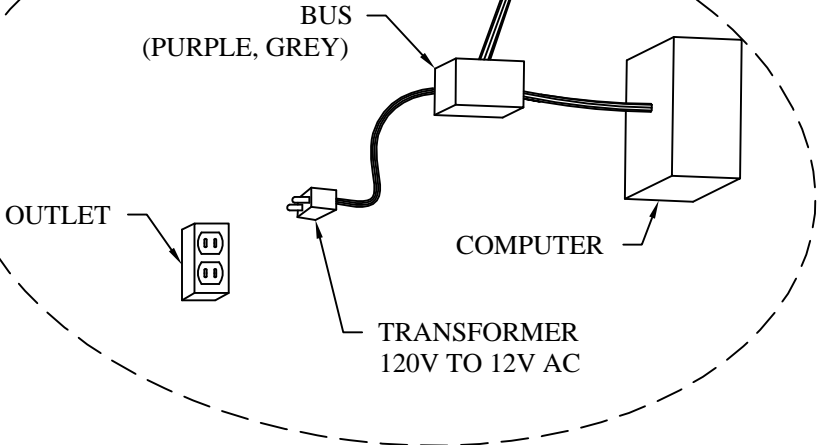

1. BLACK (LINE 1)
2. RED (LINE 2)
3. WHITE (NEUTRAL)
4. GREEN (GROUND)
5. PURPLE (DALI CONTROL)
6. GREY (DALI CONTROL)

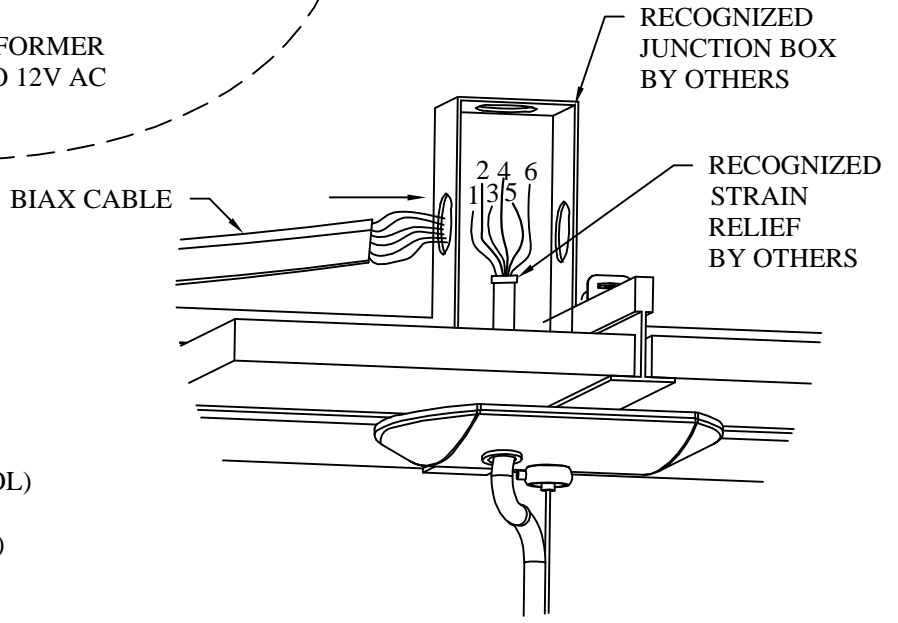

NOTE: If supply wires are located within three inches (76.2mm) of ballast, use wire rated for at least 90 °C