

READ AND UNDERSTAND THESE INSTRUCTIONS BEFORE INSTALLING FIXTURE

This fixture is intended for installation in accordance with the National Electrical Code and local regulations. To assure full compliance with local codes and regulations, check with your local electrical inspector before installation. To prevent electrical shock, turn off electricity at fuse box before proceeding.

Retain these instructions for maintenance reference.

INSTRUCTION SHEET NO.

IS:LW6U

A0397

Page 1 of 1

INSTALLATION PROCEDURE FOR: LW6CLP; LW6GDP; LW6BKP; LW6CLW; LW6GDW; LW6BKW; LW7CLP; LW7GDP; LW7BKP; LW7CLW; LW7GDW; LW7BKW — LENS WALL WASHER CONE TRIM AND LW7U — LENS WALL WASHER LAMP/YOKE ASSEMBLY

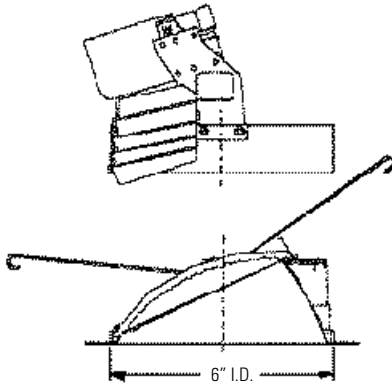

FIG. 1 – LAMP/YOKE ASSEMBLY & LENS WALL WASHER TRIM

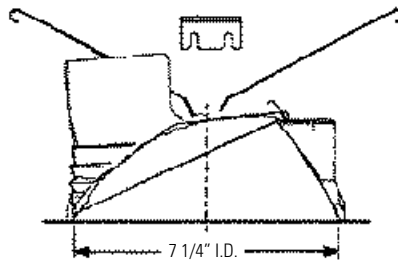

FIG. 2 – LENS WALL WASHER TRIM

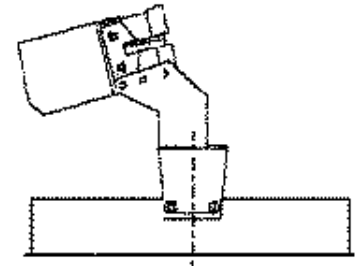

FIG. 3 – LAMP/YOKE ASSEMBLY

A. INSTALLATION PROCEDURE FOR LAMP/YOKE ASSEMBLY AND LENS WALL WASHER IN PROSPEC FIXTURES

1. **INSTALL LAMP/YOKE ASSEMBLY (Figs. 1 & 3)**
Insert LAMP/YOKE ASSEMBLY through aperture opening and push LAMP/YOKE ASSEMBLY up against FRAME SPRINGS until flush with top of FRAME RING. (Fig. 4)
2. **HORIZONTAL ANGLE ADJUSTMENT/LOCK (Fig. 4)**
Rotate LAMP/YOKE ASSEMBLY so LAMP RING is opposite the WALL (358°). Insert blade of screwdriver into SLOT of TAB and twist into FRAME RING to lock ASSEMBLY in position.
3. **REMOVE LAMP/YOKE ASSEMBLY**
By pushing TAB outward reverse Step 2 Locking. Insert blade of screwdriver against SPRING and pull down. (Fig. 5)
4. **INSTALL LENS WALL WASHER IN PROSPEC FIXTURES**
Squeeze the two TORSIONTITE SPRINGS and push them through the SLOTS in the YOKE until trim is flush with ceiling. (Fig. 6)

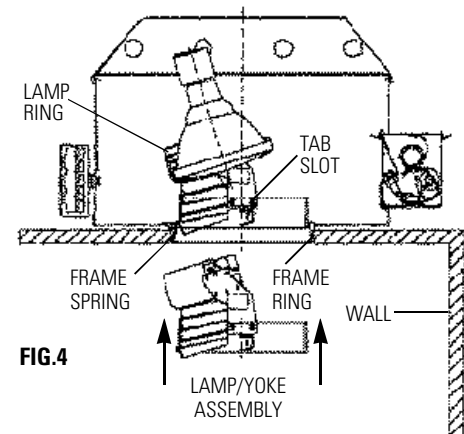

FIG. 4

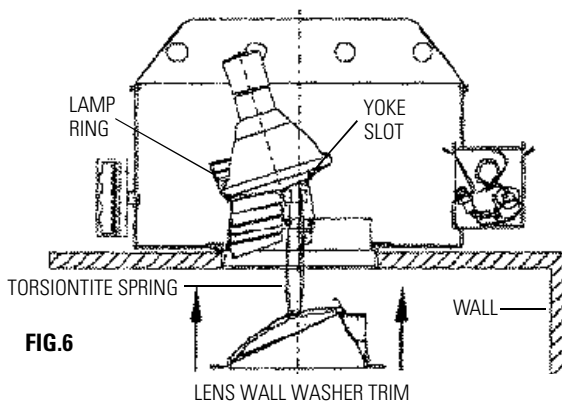

FIG. 6

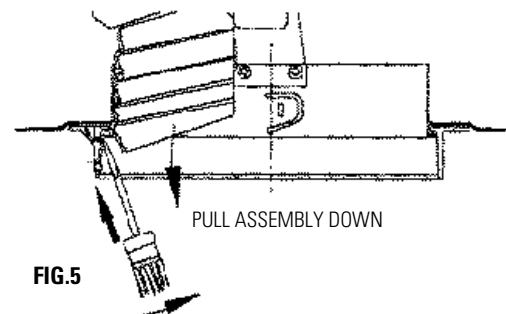

FIG. 5

LIGHTOLIER®

LIGHTOLIER a GENLYTE company.

631 Airport Road, Fall River, MA 02720