

## READ AND UNDERSTAND THESE INSTRUCTIONS BEFORE INSTALLING FIXTURE

This fixture is intended for installation in accordance with the National Electrical Code and local regulations. To assure full compliance with local codes and regulations, check with your local electrical inspector before installation. To prevent electrical shock, turn off electricity at fuse box before proceeding.

**Retain these instructions for maintenance reference.**

INSTRUCTION SHEET NO.

# IS:8292

0203

Page 1 of 2

## INSTRUCTIONS FOR THE OPERATION AND ATTACHMENT OF POWERARC™ TO A LYTESPAN® TRACK SYSTEM. FOR USE WITH LYTESPAN TRACK SYSTEMS ONLY.

### INSTRUCTIONS FOR ATTACHING ADAPTER TO SINGLE CIRCUIT LYTESPAN TRACK:

1. Position LEVER as shown in Fig. 1.
2. Align GROOVE in ADAPTER with BEAD on TRACK. See Fig. 1. (If GROOVE of ADAPTER is not placed over BEAD in TRACK, a potential hazard may result.)
3. Insert ADAPTER into TRACK.
4. Rotate LEVER 90° while pushing upward on ADAPTER, to make mechanical and electrical connection. See Fig. 2.

To remove or change fixture location on the TRACK, reverse procedure #4 above.

### INSTRUCTIONS FOR CONVERTING POWERARC ATTACHMENT FITTING TO OPERATE ON 2 CIRCUIT LYTESPAN TRACK:

**NOTE:** To insure proper operation of POWERARC on Two Circuit Lytespan Track, the BLACK SPACER (provided) must be used at all times on the plug assembly. The BLACK SPACER is not used when operating POWERARC on Single Circuit Track.

LOWER CIRCUIT, Fig. 3 & 6:

Illustrates contacts in low position with spacer in place for lower circuit.

UPPER CIRCUIT, Fig. 4, 5, & 6:

To convert attachment fitting for upper circuit, raise BRASS CONTACT to high position (as indicated by dotted line) by pulling CONTACT as high as stop permits and slipping on BLACK SPACER as shown in Fig. 4 & 5.

**Do not try to move stationary silver contact.**

### AIMING ADJUSTMENTS:

**CAUTION: ALLOW TIME FOR FIXTURE TO COOL BEFORE MAKING ANY ADJUSTMENTS!**

Rotate fixture both HORIZONTALLY and VERTICALLY to the desired position. Fixture has horizontal and vertical rotation stops (DO NOT FORCE FIXTURE PAST STOPS. DOING SO MAY CAUSE AN ELECTRICAL HAZARD) See FIG. 7. For precise VERTICAL rotation, rotate HEAD of fixture and line up desired angle on the AIMING ANGLE INDICATOR with the INDICATOR TAB (See FIG. 8).

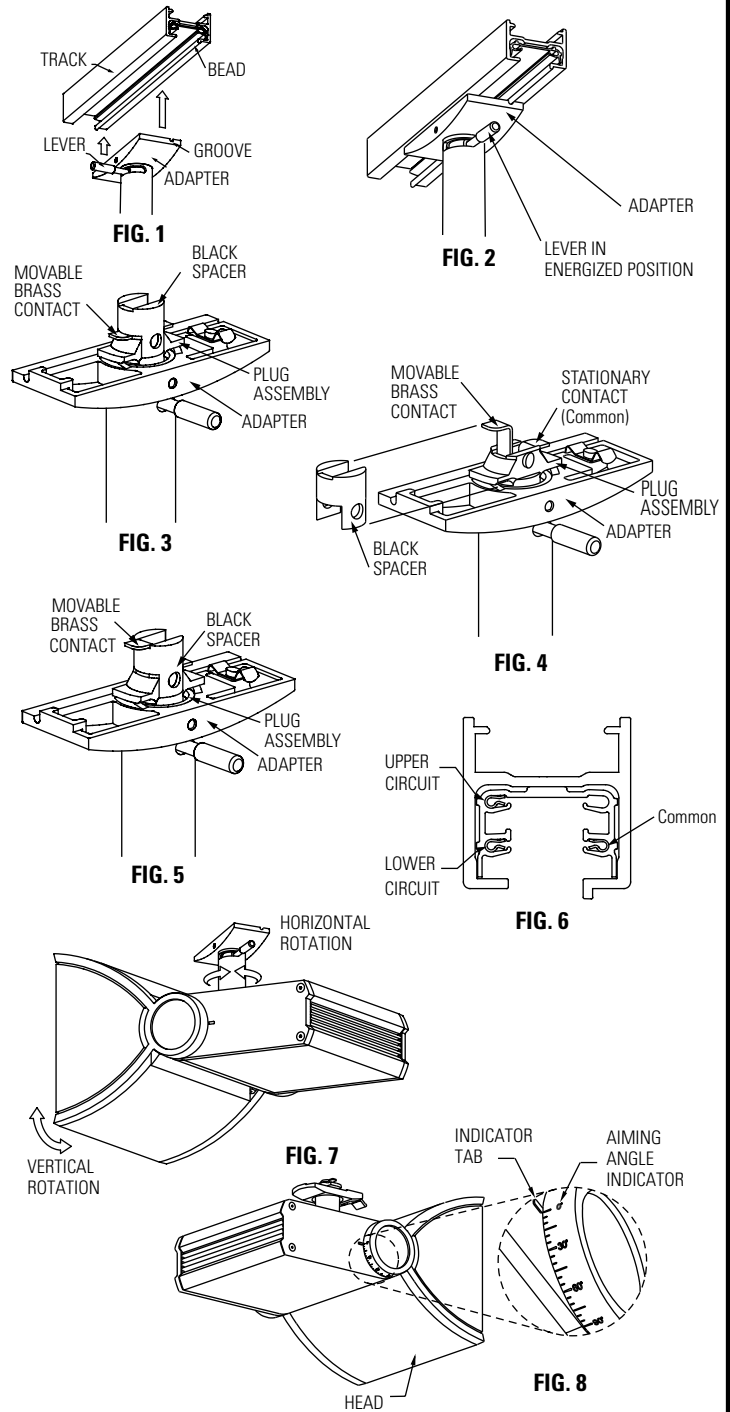

# LIGHTOLIER®

LIGHTOLIER a GENLYTE company.

631 Airport Road, Fall River, MA 02720

## READ AND UNDERSTAND THESE INSTRUCTIONS BEFORE INSTALLING FIXTURE

This fixture is intended for installation in accordance with the National Electrical Code and local regulations. To assure full compliance with local codes and regulations, check with your local electrical inspector before installation. To prevent electrical shock, turn off electricity at fuse box before proceeding.

**Retain these instructions for maintenance reference.**

INSTRUCTION SHEET NO.

# IS:8292

0203

Page 2 of 2

## INSTRUCTIONS FOR OPERATING AND LAMPING A POWERARC FIXTURE

### INSTRUCTIONS FOR LAMPING A POWERARC FIXTURE:

1. Turn off power to fixture.
2. Remove the LENS by inserting finger into SLOT A and pressing the LENS in the direction of SLOT B (See FIG. 9).
3. Carefully rotate LENS out of SLOT A in the direction shown in FIG. 10.
4. Slide glass out of SLOT B by pulling the LENS in the direction of SLOT A (See FIG. 11).
5. To insert LAMP (70W CDM or CMH T-6 Double Ended Metal Halide M85), carefully push one end of the LAMP CONTACT into one end of the SOCKET CONTACT until the other end of the LAMP can be inserted into the opposite SOCKET (See FIG. 12).

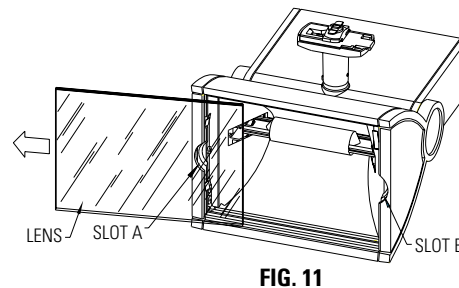
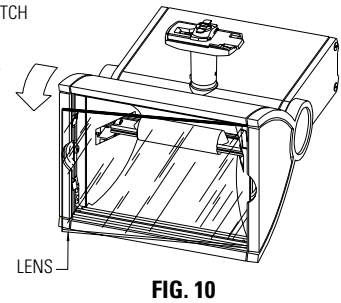
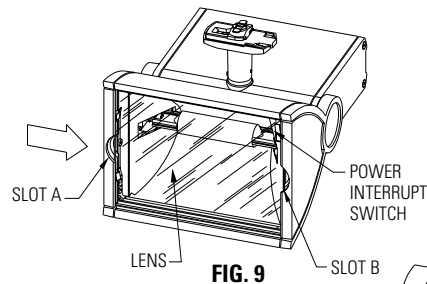

**WARNING: ACCORDING TO MANUFACTURER'S INSTRUCTIONS, LAMP SHOULD BE INSERTED IN THE SOCKET WITH A MINIMUM ANGLE OTHERWISE BENDING FORCES WILL RESULT IN LAMP BREAKAGE. ALSO, INSTALL LAMP USING PROTECTIVE PAPER AND DO NOT REMOVE IT UNTIL INSTALLATION IS COMPLETE. IF LAMP IS TOUCHED WITH BARE HANDS, CLEAN LAMP WITH DENATURED ALCOHOL AND WIPE WITH LINT FREE CLOTH.**

6. Insure both LAMP CONTACTS are properly seated into the SOCKET CONTACTS (See FIGS. 12 & 13).
7. To re-insert LENS: First insert LENS in SLOT A (side with no switch), carefully push the LENS until you can set it flat into the face of the fixture. Make sure it presses the INTERRUPT SWITCH, then engage LENS into SLOT B.

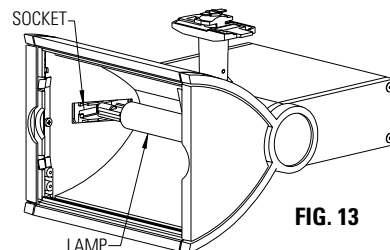
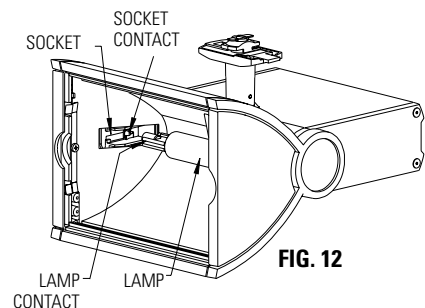

**WARNING: IF USED IMPROPERLY, THIS LAMP CAN CAUSE SERIOUS SKIN BURN AND EYE INFLAMMATION FROM SHORTWAVE ULTRAVIOLET RADIATION. DO NOT OPERATE FIXTURE WITHOUT PROTECTIVE LENS IN PLACE. FIXTURE IS EQUIPPED WITH A POWER INTERRUPT SWITCH TO PREVENT LAMP FROM BEING ENERGIZED WHEN LENS IS REMOVED (SEE FIG. 9). DO NOT ATTEMPT TO DISABLE THIS DEVICE.**

# LIGHTOLIER®

LIGHTOLIER a GENLYTE THOMAS company.  
631 Airport Road, Fall River, MA 02720