

READ AND UNDERSTAND THESE INSTRUCTIONS BEFORE INSTALLING FIXTURE

This fixture is intended for installation in accordance with the National Electrical Code and local regulations. To assure full compliance with local codes and regulations, check with your local electrical inspector before installation. To prevent electric shock, turn off electricity at fuse box before proceeding.

Retain these instructions for maintenance reference.

INSTRUCTION SHEET NO.

IS:C6E17OW

A0904

Page 1 of 1

INSTALLATION INSTRUCTIONS FOR 6" AND 7" RECESSED EVOLUTION H.I.D. OPEN WALL WASHER DOWNLIGHT TRIMS.

CAUTION: (RISK OF FIRE) DO NOT INSTALL INSULATION ABOVE NOR WITHIN 3 INCHES (76mm) OF ANY PART OF THE LUMINAIRE (LIGHTING FIXTURE)

CAUTION: USE ONLY ROUGH-IN SECTIONS PROVIDED BY LIGHTOLIER. USE OF OTHER MANUFACTURERS' ROUGH-IN KITS WILL VOID THE UNDERWRITERS LABORATORIES LISTING AND COULD CONSTITUTE A FIRE HAZARD.

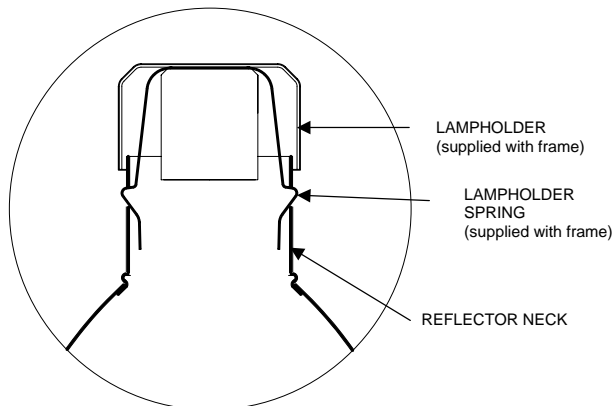

Fig. 1

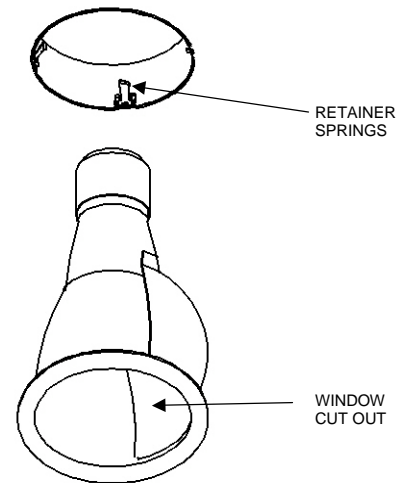

Fig. 2

Installing Lampholder onto Reflector (Fig. 1)

1. Bring LAMPHOLDER through frame opening into workspace.
2. Snap LAMPHOLDER SPRING into two slots on REFLECTOR NECK.
3. Check to make sure that both sides of LAMPHOLDER SPRING are fully engaged into slots.
4. Reflector trim is now ready for installation into ceiling.

Installing Reflector into Frame (Fig. 2) & (Fig. 3)

1. Feed assembled REFLECTOR into frame opening by aligning WINDOW CUT OUT between RETAINER SPRINGS. WINDOW CUT OUT must be opposite the wall to be illuminated as shown.
2. Push up on flange until it is fully installed into frame opening.

Re-lamping

1. To re-lamp one-piece units, simply unscrew the old lamp and replace with a new one. There is no need to remove trim from ceiling.
2. See trim labeling for correct lamp info. Follow lamp manufacturer's directions for proper care and handling of lamp.

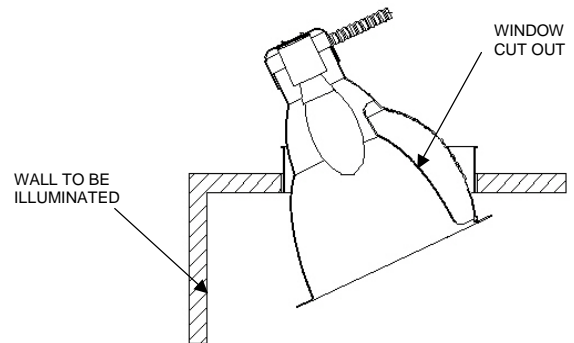

Fig. 3

Care and Maintenance of "Alzak" REFLECTOR TRIM finish:

If handling of REFLECTOR TRIM with anodized or Alzak finish is required, the use of clean white or plastic film gloves is recommended to avoid fingerprints.

Anodized or Alzak surfaces can be cleaned by the following methods:

1. Wipe off with a soft, clean, dry, lint-free cloth.
2. Wipe off with a soft clean cloth dampened in mild detergent solution. Rinse, then wipe dry with lint-free cloth or paper towel.
3. Wipe off with a clean cloth dampened with a solution of wetting agent and water (such as 2 oz. Per gallon "Pluronic L62-LF" by Wyandotte Products). Wipe dry.
4. Use a liquid wax such as Glass Wax®. Avoid gritty cleaning agents.

LIGHTOLIER®

LIGHTOLIER A GENLYTE THOMAS COMPANY
631 Airport Road, Fall River, MA 02720