

One Lamp Installation

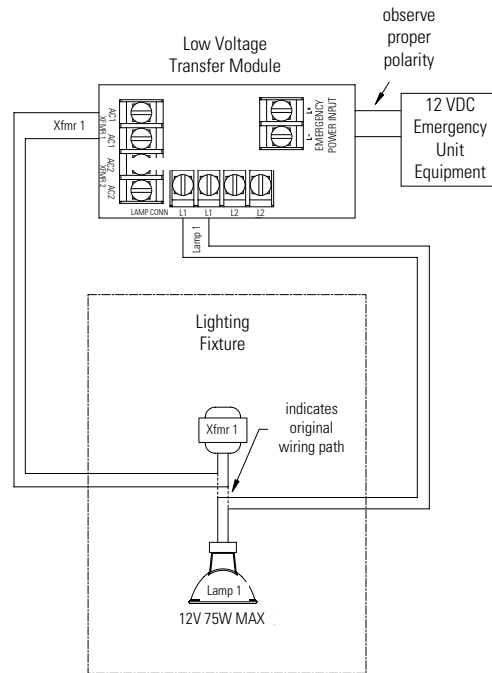

Two Lamp Installation

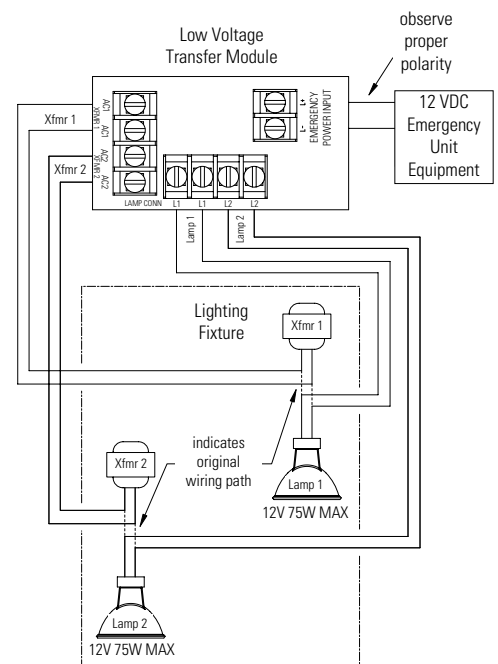

Complete Fixture consists of base unit.

How to Specify:

LTC

Model Series

LTC = Low Voltage Transfer Circuit

General Description

The Low Voltage Transfer Circuit is designed to allow the user to combine their existing low voltage lighting with a 12 VDC emergency unit power pack such as Lightolier's C3 Series. The low voltage lighting may continue to be controlled by a wall switch or dimmer control for normal usage. In the event of utility power failure, the Low Voltage Transfer Circuit will allow the 12 volt emergency power unit to supply power directly to the lamps of the low voltage lighting fixture.

Features

- 1. Illumination:** The Low Voltage Transfer Circuit is a two channel device providing switching for up to 75 watts per channel.
- 2. Housing:** Housing and cover are constructed of 20 gauge galvanized steel. Three knockouts for conduit attachment are provided. A grounding lead is provided inside the housing.
- 3. Installation:** Two #8 sheet metal screws are provided for mounting the Low Voltage Transfer Module. Three knockouts are provided for the attachment of conduit. A grounding lead is supplied inside the housing. The LTC is listed for use in insulated ceilings. (IC rated).
- 4. Electronics (Load):** Reverse Polarity protected with low battery voltage disconnect (standard in all Lightolier emergency battery units.)
- 5. Electronics (Special Requirement):** Determine the maximum wattage draw of the down-light fixture and be certain that the 12 VDC emergency supply unit equipment is capable of sustaining that load for a minimum of 90 minutes as required by code.
- 6. Input Power Requirements:** 120 VAC - .72W
- 7. Output Power Requirements:** 120 VDC - 2 channel at 75W max each

Warranty

Electronics: 3 years full

Code Compliance

Listed for Insulated Ceiling Systems (IC rated), Damp location listing standard - 32°F (0°C) to 122°F (50°C), ETL listed to UL 924 standards

Job Information

Type:

Job Name:

Cat. No.:

Lamp(s):

Notes:

631 Airport Road, Fall River, MA 02720 • (508) 679-8131 • Fax (508) 674-4710
 We reserve the right to change details of design, materials and finish.
 www.lightolier.com © 2008 Philips Group • B0308