

## READ AND UNDERSTAND THESE INSTRUCTIONS BEFORE INSTALLING FIXTURE

This fixture is intended for installation in accordance with the National Electrical Code and local regulations. To assure full compliance with local codes and regulations, check with your local electrical inspector before installation. To prevent electric shock, turn off electricity at fuse box before proceeding.

**Retain these instructions for maintenance reference.**

INSTRUCTION SHEET NO.

# IS:406BLS

A0105

Page 1 of 1

INSTRUCTIONS FOR 6.5" PENDALYTE™ SERIES TRACK MOUNT TO LYESPAN® TRACK SYSTEM SUSPENSION KITS. FOR USE WITH LYESPAN TRACK SYSTEMS ONLY.

**CAUTION: MAXIMUM WATTAGE AS MARKED ON LUMINAIRE MUST NOT BE EXCEEDED.**

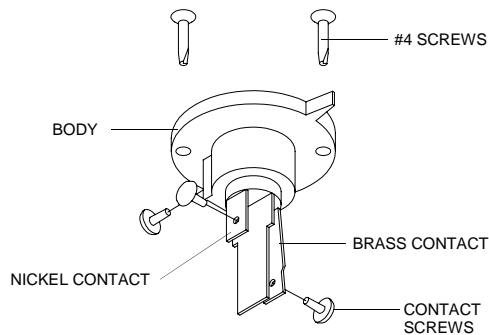

### POWER STEM INSTALLATION (fig. 1)

1. Slide STEM and BUSHING over POWERCORD. Align end of POWERCORD with top of BUSHING tighten SET SCREW to secure POWERCORD.
2. Twist stripped ends of POWERCORD wires and attach using CONTACT SCREWS: attach hot (black POWERCORD lead to long BRASS CONTACT, attach neutral (white) POWERCORD lead to short NICKEL CONTACT, attach POWERCORD ground lead (green) to BODY with green CONTACT SCREW.
3. Slide STEM up over contacts and secure to BODY using #4 SCREWS.

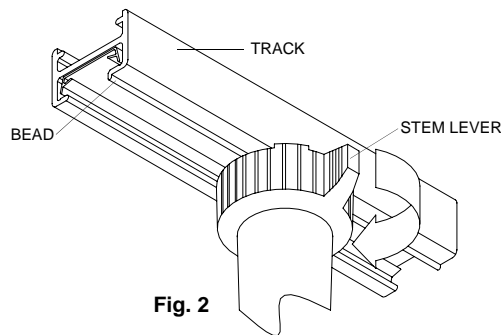
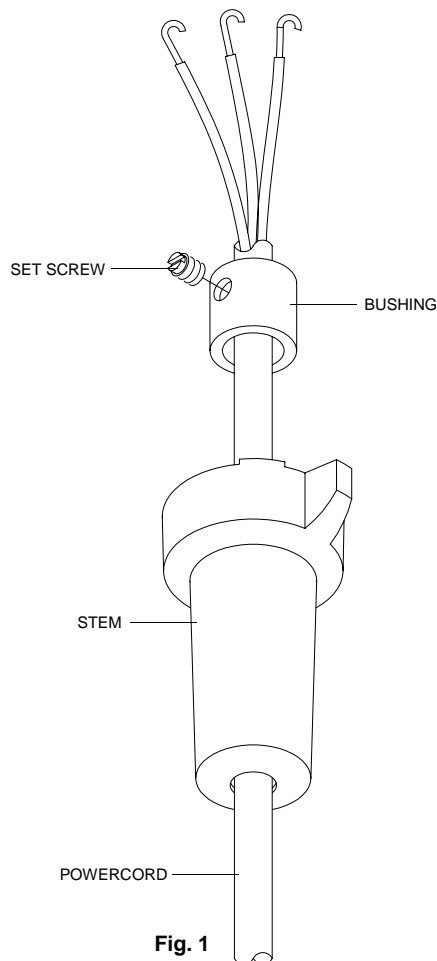

**NOTE:** Not for use with ProSpec track.



**WARNING:** TO PREVENT ELECTRIC SHOCK, TURN OFF POWER TO TRACK.

### INSTALLATION INTO TRACK (fig. 2)

1. Turn off power to TRACK.
2. Insert POWER STEM into track. The STEM LEVER must be on the same side as the track bead. See fig. 2.
3. Rotate suspension stem 90° clockwise using STEM LEVER. STEM LEVER should be parallel to TRACK.
4. To remove: rotate SUSPENSION STEM 90° counterclockwise using STEM LEVER.

# LIGHTOLIER®

LIGHTOLIER A GENIYTE THOMAS COMPANY  
631 Airport Road, Fall River, MA 02720