

READ AND UNDERSTAND THESE INSTRUCTIONS BEFORE INSTALLING FIXTURE

This fixture is intended for installation in accordance with the National Electrical Code and local regulations. To assure full compliance with local codes and regulations, check with your local electrical inspector before installation. To prevent electric shock, turn off electricity at fuse box before proceeding.

Retain these instructions for maintenance reference.

INSTRUCTION SHEET NO.

IS:C4P20MH

B0904

Page 1 of 2

INSTALLATION INSTRUCTIONS FOR 4", 6", AND 7" RECESSED EVOLUTION H.I.D. DOWNLIGHT TRIMS.

CAUTION: (RISK OF FIRE) DO NOT INSTALL INSULATION ABOVE NOR WITHIN 3 INCHES (76mm) OF ANY PART OF THE LUMINAIRE (LIGHTING FIXTURE)

CAUTION: USE ONLY ROUGH-IN SECTIONS PROVIDED BY LIGHTOLIER. USE OF OTHER MANUFACTURERS' ROUGH-IN KITS WILL VOID THE UNDERWRITERS LABORATORIES LISTING AND COULD CONSTITUTE A FIRE HAZARD.

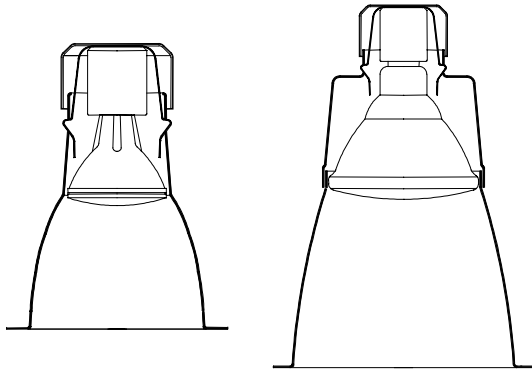

PAR-type Open
Downlights,
1-Piece Construction

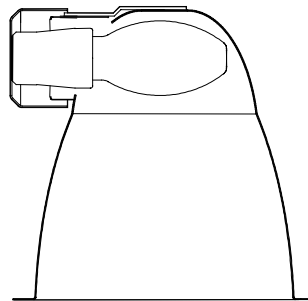

ED17 Horizontal Lamp
1-piece Construction

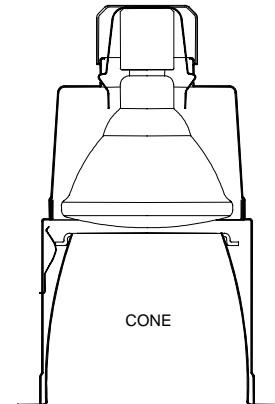

PAR-type Open
Downlights,
2-Piece Construction

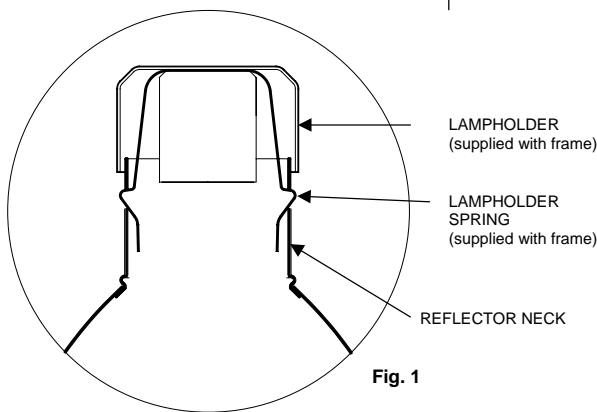

Fig. 1

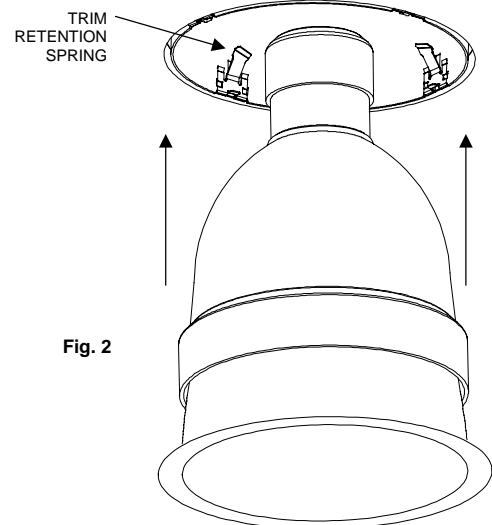

Fig. 2

Installing Lampholder onto Reflector (Fig. 1)

1. Bring LAMPHOLDER through frame opening into workspace.
2. Snap LAMPHOLDER SPRING into two slots on REFLECTOR NECK.
3. Check to make sure that both sides of LAMPHOLDER SPRING are fully engaged into slots.
4. Reflector trim is now ready for installation into ceiling.

Installing Reflector into Frame (Fig. 2)

1. Install LAMPHOLDER onto REFLECTOR NECK.
2. Feed assembled REFLECTOR into frame opening by aligning as shown, and pushing up on FLANGE until it is fully installed into frame opening.

Re-lamping

1. To re-lamp one-piece units, simply unscrew the old lamp and replace with a new one. There is no need to remove trim from ceiling.
2. For two-piece constructions, remove CONE by pulling out of trim assembly, re-lamp, and then replace CONE.
3. See trim labeling for correct lamp info. Follow lamp manufacturer's directions for proper care and handling of lamp.

LIGHTOLIER®

LIGHTOLIER A GENLYTE THOMAS COMPANY
631 Airport Road, Fall River, MA 02720

READ AND UNDERSTAND THESE INSTRUCTIONS BEFORE INSTALLING FIXTURE

This fixture is intended for installation in accordance with the National Electrical Code and local regulations. To assure full compliance with local codes and regulations, check with your local electrical inspector before installation. To prevent electric shock, turn off electricity at fuse box before proceeding.

Retain these instructions for maintenance reference.

INSTRUCTION SHEET NO.

IS:C4P20MH

B0904

Page 2 of 2

INSTALLATION INSTRUCTIONS FOR 4", 6", AND 7" RECESSED EVOLUTION H.I.D. DOWNLIGHT TRIMS.

CAUTION: (RISK OF FIRE) DO NOT INSTALL INSULATION ABOVE NOR WITHIN 3 INCHES (76mm) OF ANY PART OF THE LUMINAIRE (LIGHTING FIXTURE)

CAUTION: USE ONLY ROUGH-IN SECTIONS PROVIDED BY LIGHTOLIER. USE OF OTHER MANUFACTURERS' ROUGH-IN KITS WILL VOID THE UNDERWRITERS LABORATORIES LISTING AND COULD CONSTITUTE A FIRE HAZARD.

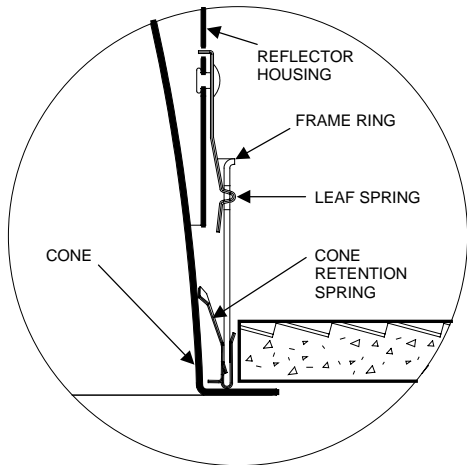

Installation of 2-piece type construction

1. Install REFLECTOR HOUSING into FRAME RING by aligning LEAF SPRINGS with slots in upper portion of FRAME RING.
2. All LEAF SPRINGS must fully engage with slots for correct installation.
3. Install CONE by pushing up into opening. CONE RETENTION SPRINGS will hold CONE in place.

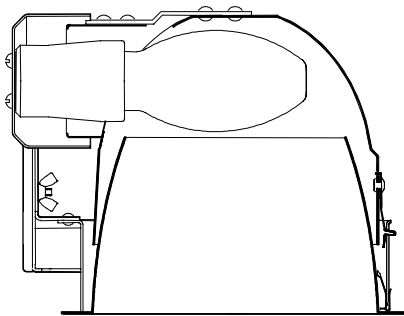

ED17 Horizontal Lamp
2-piece Construction

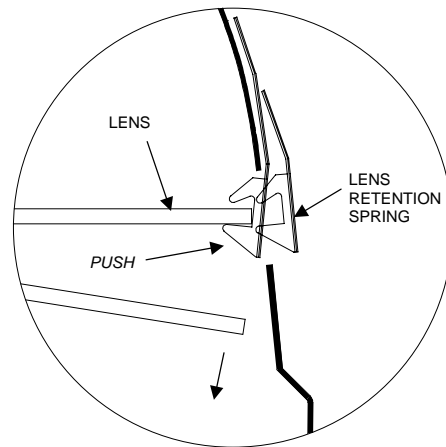

Detail of Lens Removal and Replacement

1. On some trims, it will be necessary to remove the lens prior to re-lamping.
2. To remove LENS, push on one LENS RETENTION SPRING to disengage it from the edge of the LENS.
3. The LENS should easily come free from the remaining LENS RETENTION SPRINGS.
4. To replace, insert edge of LENS into all but one of the LENS RETENTION SPRINGS.
5. Push LENS up to snap it into the remaining LENS RETENTION SPRING.

Care and Maintenance of "Alzak" REFLECTOR TRIM finish:

If handling of REFLECTOR TRIM with anodized or Alzak finish is required, the use of clean white or plastic film gloves is recommended to avoid fingerprints.

Anodized or Alzak surfaces can be cleaned by the following methods:

1. Wipe off with a soft, clean, dry, lint-free cloth.
2. Wipe off with a soft clean cloth dampened in mild detergent solution. Rinse, then wipe dry with lint-free cloth or paper towel.
3. Wipe off with a clean cloth dampened with a solution of wetting agent and water (such as 2 oz. Per gallon "Pluronic L62-LF" by Wyandotte Products). Wipe dry.
4. Use a liquid wax such as Glass Wax®. Avoid gritty cleaning agents.

LIGHTOLIER®

LIGHTOLIER A GENLYTE THOMAS COMPANY
631 Airport Road, Fall River, MA 02720