



MT108-102 is shown above.

MANUAL PART NUMBER: 400-0162-002

MT108-102/MT108-103

1-IN, 4-OUT STEREO AUDIO DISTRIBUTION AMPLIFIER CARDS FOR MULTI-TASKER™ USER'S GUIDE

TABLE OF CONTENTS

	Page
PRECAUTIONS / SAFETY WARNINGS	2
1.1 GENERAL.....	2
1.2 INSTALLATION	2
1.3 CLEANING.....	2
1.4 FCC / CE NOTICE	2
ABOUT YOUR MT108-102/(103)	3
TECHNICAL SPECIFICATIONS	3
DESCRIPTION OF MT108-102/(103)	4
APPLICATION DIAGRAM.....	4
INSTALLING YOUR MT108-102/(103).....	6
OPERATION (FOR MT108-103 ONLY)	6
7.1 RS-232 CONTROL	6
7.2 DESCRIPTION OF COMMANDS.....	6
7.3 SUMMARY OF COMMANDS.....	10
TROUBLESHOOTING GUIDE	11
8.1 LED IS NOT LIT.....	11
8.2 NO SOUND.....	11
8.3 SOUND DISTORTION.....	11
8.4 SOUND LEVEL IS LOW	11
ALTINEX POLICY	12

PRECAUTIONS / SAFETY WARNINGS 1

Please read this manual carefully before using your **MT108-102/(103)** Distribution Amplifier. Keep this manual handy for future reference. These safety instructions are to ensure the long life of your **MT108-102/(103)** and to prevent fire and shock hazard. Please read them carefully and heed all warnings.

1.1 GENERAL

- Qualified ALTINEX service personnel, or their authorized representatives must perform all service.

1.2 INSTALLATION

- To prevent fire or shock, do not expose this unit to rain or moisture. Do not place the **MT108-102/(103)** in direct sunlight, near heaters or heat radiating appliances, or near any liquid. Exposure to direct sunlight, smoke, or steam can harm internal components.
- Handle the **MT108-102/(103)** carefully. Dropping or jarring can damage the card.
- Do not pull the cables that are attached to the **MT108-102/(103)**.
- Insert the card carefully into the slots of the Multi-Tasker™ without bending any edges.
- When removing a card, please make sure that the card to which it is attached is also pulled out simultaneously.

1.3 CLEANING

- Clean only the connector area with a dry cloth. Never use strong detergents or solvents, such as alcohol or thinner. Do not use a wet cloth or water to clean the card. Do not clean or touch any component or PCB.

1.4 FCC / CE NOTICE

- This device complies with part 15 of the FCC Rules. Operation is subject to the following two conditions: (1) This device may not cause harmful interference, and (2) this device must accept any interference received, including interference that may cause undesired operation.

- This equipment has been tested and found to comply with the limits for a Class A digital device, pursuant to Part 15 of the FCC Rules. These limits are designed to provide reasonable protection against harmful interference when the equipment is operated in a commercial environment. This equipment generates, uses, and can radiate radio frequency energy and, if not installed and used in accordance with the instruction manual, may cause harmful interference to radio communications. Operation of this equipment in a residential area is likely to cause harmful interference in which case the user will be required to correct the interference at his own expense.
- Any changes or modifications to the unit not expressly approved by ALTINEX, Inc. could void the user's authority to operate the equipment.

ABOUT YOUR MT108-102/(103) 2

MT108-102/(103) 1-in 4-out Stereo Audio Distribution Amplifier Cards

The **MT108-102** and **MT108-103** are Stereo, Audio Distribution Amplifier Cards designed for use with the Multi-Tasker™ system. When installed in a Multi-Tasker™, these cards allow the connection of a single stereo, audio source to four receiving devices. All inputs and outputs are balanced, allowing longer cable runs and superior noise reduction.

As “transparent” distribution amplifiers, these cards utilize AC coupling on their inputs for ideal signal transfer characteristics. The power indicator on the card doubles as a signal detection indicator, allowing easy troubleshooting in complex configurations. Each card consumes one slot in the Multi-Tasker™ enclosure.

The **MT108-103** also has the ability to independently turn on or off each output under the control of RS-232 commands sent to the Multi-Tasker™ enclosure.

TECHNICAL SPECIFICATIONS 3

FEATURES/DESCRIPTION	MT108-102/(103)
GENERAL	
Inputs	
Input Connector	(1) 5-pin terminal block L+, L-, GND, R+ & R-
Outputs	
Output Connector	(4) 5-pin terminal blocks L+, L-, GND, R+ & R-
Compatibility	Balanced Stereo Audio

Table 1. **MT108-102/(103)** General

MECHANICAL	MT108-102/(103)
Basic Enclosure Slots Required	One
T° Operating	10°C-40°C
T° Storage	0 to 50°C
Humidity	90% non-condensing
MTBF (calc.)	40,000 hrs

Table 2. **MT108-102/(103)** Mechanical

ELECTRICAL	MT108-102/(103)			
Audio Input				
Impedance	10k Ohms			
Coupling	AC			
Audio Throughput				
Gain	0 dB			
Signal Amplitude	+/-3V			
Frequency Response	10Hz to 20kHz (+/-0.05dB)			
Noise Floor	-100 dB @ 20 kHz			
CMRR	>80 dB, 10 Hz to 20 kHz			
Audio Output				
Level, Each Channel	1V p-p			
Impedance	600 Ohms			
Gain	0 dB			
Power				
Power from MT100-100	+6V	+13V	-13V	Power Consumption
MT108-102	45 mA	45 mA	45 mA	1.2 watts
MT108-103	80 mA	45 mA	45 mA	1.7 watts

Table 3. **MT108-102/(103)** Electrical

DESCRIPTION OF MT108-102/(103) 4

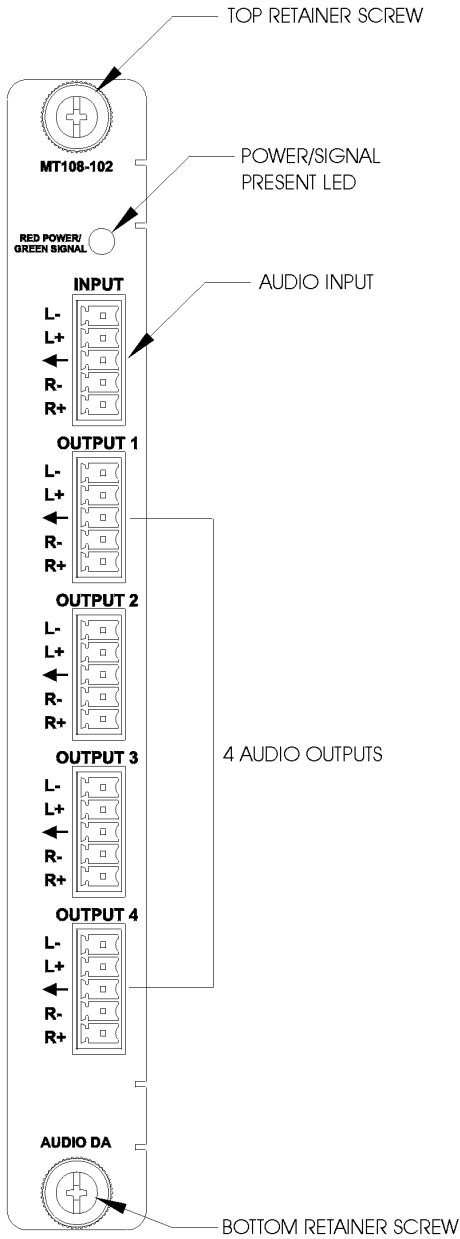

APPLICATION DIAGRAM 5

Application 1

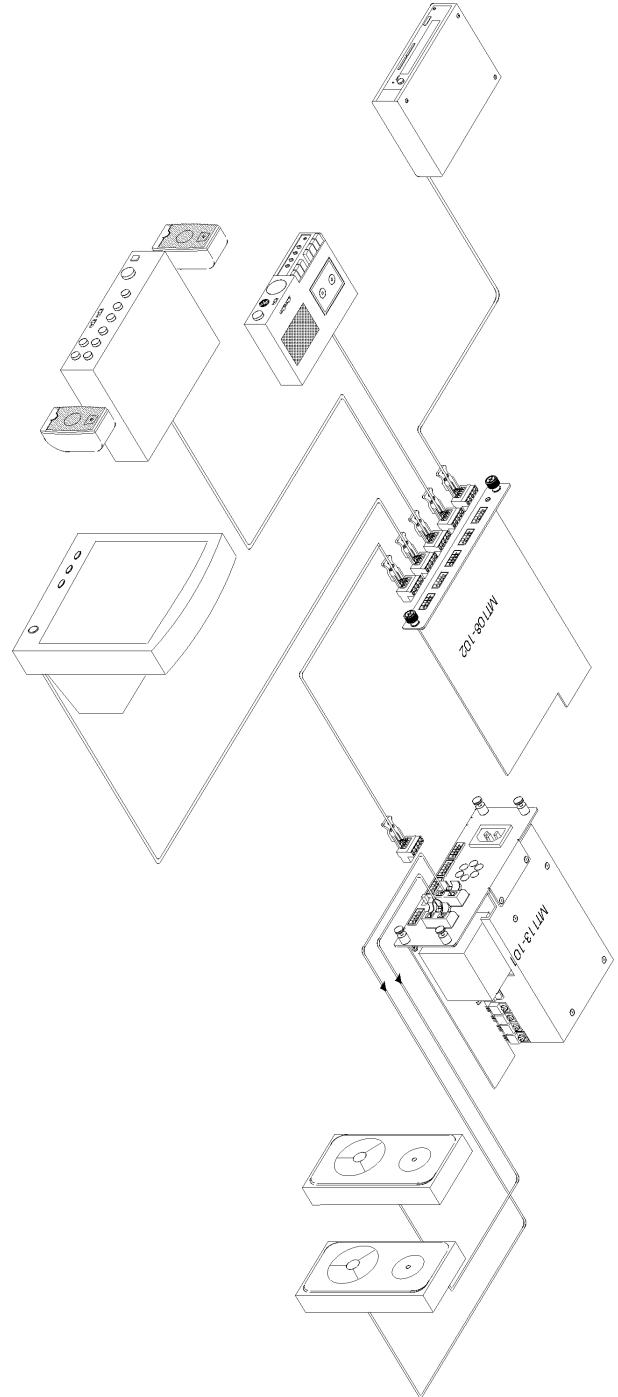

Application 2 Internal View of the MT108-102/(103) Card

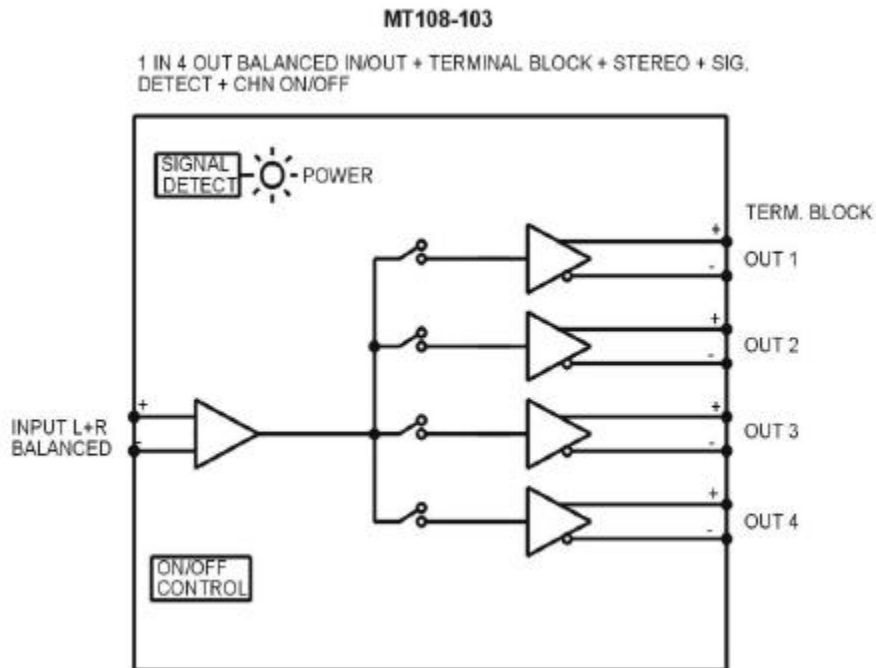
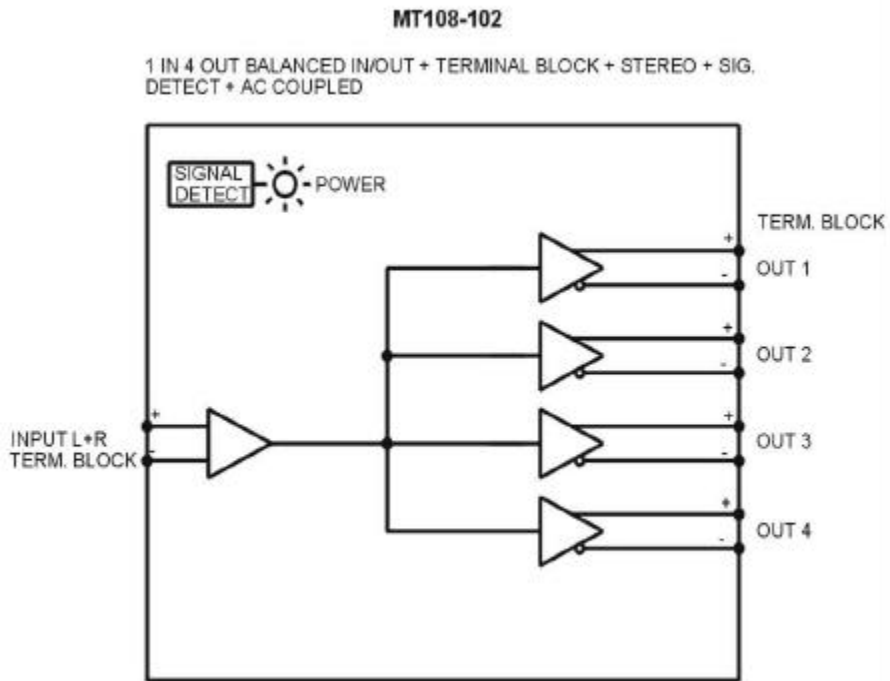

INSTALLING YOUR MT108-102/(103) 6

- Step 1.** Slide the **MT108-102/(103)** into an available slot in the Multi-Tasker™ Basic Enclosure in order to connect to the bus. Make sure that the **MT108-102/(103)** Stereo Audio DA Card fits into place. Secure the card to the Multi-Tasker™ by tightening the retainer screws located on the top and bottom of the **MT108-102/(103)** Stereo Audio DA Card.
- Step 2.** The LED on the card panel will turn red indicating that the card is in full operation. A green LED indicates that an input signal is present. An LED that is blinking red indicates that the card is experiencing a problem. If the LED is blinking, see the Troubleshooting Guide in section 8.
- Step 3.** Connect an audio cable from the audio source to the input connector of the **MT108-102/(103)**. Connect any or all of the four available outputs of the **MT108-102/(103)** to audio equipment.
- Step 4.** Starting from the left, identify the slot number where the **MT108-102/(103)** card is plugged into the Enclosure and note that it is for RS-232 control.

OPERATION (for MT108-103 only) 7

7.1 RS-232 CONTROL

The outputs of the **MT108-102** are always enabled; therefore, no RS-232 control is necessary.

When used in the Multi-Tasker™ Basic Enclosure, the **MT108-103** has many advanced remote control capabilities, which are accessible through standard RS-232 communication. The actual control may be performed using a computer control system or any other device capable of sending RS-232 commands.

7.1.1 RS-232 INTERFACE

The RS-232 commands for the **MT108-103** are in a simple ASCII character format.

1. Square brackets “[]” are part of the command.
2. Use uppercase letters for all commands.

After processing a command, an OK or ER string will be returned as feedback if "F" is included at the end of a command string or if the unit ID is zero.

7.2 DESCRIPTION OF COMMANDS

Each command consists of three parts: function, card ID, and unit ID. [Function, Card ID, Unit ID].

Example:

[VERC3U2]

VER = Function

C3 = Card ID

U2 = Unit ID

For function, see a detailed explanation under each command description.

The Card ID is an assigned value from 1 to 19, based on which slot the card is put in. The Card ID 0 (C0) is used for the controller (see user's guide for the MT100-100). Changing the position of a card will significantly affect the commands recorded on software definitions or a third party control system.

Unit ID has a value from 0 to 9. Unit ID 0 should be used for single unit operation. If the Unit ID is set to 0, then each command can be used without Ui (use command [SETU0]; see user's guide for the MT100-100).

Example:

[VERC3]: for unit ID zero

[VERC3Ui]: for unit ID other than zero

[VERC3]: equivalent to [VERC3U0]

1. [VER]

This command displays the software version and card type of the **MT108-103** card.

Command Format: [VERCnUi]

Cn = card ID number (n = # from 1 to 19)

Ui = Unit ID (i = # from 0 to 9) (*refer to the MT100-100 user's guide for explanation*)

Example:

If one **MT108-103** card is plugged in slot #2 of unit 3: Sending the command [**VERC2U3**], will yield the following feedback from the Multi-Tasker™

MT108-103 690-0127-007

MT108-103 = card type
690-0127-007 = software version

2. [C]

This command receives the status of the card.

Command Format: [CnUi]

Cn = card id (n = from 1 to 19)

Ui = unit id (i = from 0 to 9) (*refer to the MT100-100 user's guide for explanation*)

Example:

If one **MT108-103** card is plugged into slot #2 of unit 3 with outputs 1 and 2 ON, sending the command [**C2U3**] will yield the following feedback:

ON: 1,2 C02

If there is no card plugged in slot #2 of unit 3, the Multi-Tasker™ will not return any feedback.

3. [CiS]

This command saves the current status of the card's output enable configuration. This configuration will be restored after system is reset or powered off then on.

Ci = card number

S = save configuration

If Inputs 1,2,3 and 4 are enabled, the feedback after sending the command [**C4S**], for slot 4, would be:

ON:1,2,3,4 C04 Saved

4. [SIG]

The Signal Present command tests for the presence of a signal on the input. After sending

the command, the feedback will be either "1" signifying a signal is present, or a "0" indicating no signal was detected.

Command Format: [SIGCnUi]

Cn = card number

Ui = unit ID

Example:

To check for the presence of an input signal on card 4, send the command [**SIGC4**] and verify feedback of "1" or "0".

5. [ON]

This command enables one or more outputs of a single card or a group of cards.

[ONmCnUi]: for a single card

This command enables output "m" without affecting any other outputs.

m = Output number (m = 1 to 4)

n = Card ID number (n = 1 to 19)

i = Unit ID number (i = 0 to 9)

Example:

- 1) [**ON12C5U3**]: Turns ON only outputs 1 and 2 of the **MT108-103** card located in slot #5 of the MT100-100 Enclosure with unit ID3.
- 2) [**ON3C5U3**]: Turns ON only output 3 of the **MT108-103** card located in slot #5 of the MT100-100 Enclosure with unit ID3. After the [**ON12C5U3**] and [**ON3C5U3**] commands have been executed, outputs 1, 2 and 3 will be ON.
- 3) [**ONC5U3**]: Turns ON all outputs of the card. This is the equivalent of sending the command [**ON1234C5U3**].

[ONmGkUi]: for a group of cards

This command enables output "m" for each card in group "k" of unit "i".

m = card output (m = # from 1-4)

k = group number (k = # from 1-9)

i = unit number (i = # from 0-9)

Example:

1. **[ON1G5U1]:** Turns ON output 1 for each card in group 5 of unit 1.
2. **[ONG5U1]:** Turns ON all outputs for each card in group 5 of unit 1.

[ON...P]: sets path

This command will set the path for the output, but it is not active until the switch command, [SW], is executed. Commands ending in "P" are not executed immediately. The path for outputs on multiple cards or the same card can be preloaded.

Command Format: [ONmCnUiP]

m = number (m = 1 to 4)
n = card ID No. (n = a slot # from 1 to 19)
i = unit ID
P = path

Example:

If 2 cards are in slot 6 and 7 of unit 3: To enable outputs 1 and 2 of card 6 and outputs 3 and 4 of card 7 simultaneously, use the following commands:

```
[ON12C6U3P]  
[ON34C7U3P]  
[SW]
```

If "F" is included use the [ONmCnUiPF] command or the [ONmCnUiFP] command.

[ON.....F]: feedback

After processing a command, an OK or ER will be returned as feedback if "F" is included at the end of a command string.

Example:

```
[ON1C2U3F]: if path is not set  
[ON1C2U3PF]: if path is set
```

6. [OFF]

This command disables one or more outputs of a single card or a group of cards.

[OFFmCnUi]: for a single card

This command disables output "m" without affecting any other outputs.

m = output number (m = 1 to 4)
n = card ID No. (n = slot # from 1 to 19)
i = Unit ID number (i = 0 to 9)

[OFFCnUi]: Turns OFF all outputs of the card

Example:

- 1) If card 5 of unit 3 has output 1, 2 and 3 ON:
 - a) **[OFF1C5U3]:** Turns OFF output 1 while outputs 2 and 3 remain ON.
 - b) **[OFF23C5]:** Turns OFF outputs 2 and 3.
- 2) If card 5 of unit 3 has outputs 1, 2, 3 and 4 ON:
 - a) **[OFFC5U3]:** Turns OFF all outputs, which is equivalent to **[OFF1234C5U3]**.

[OFFmGkUi]: for a group of cards

This command disables output "m" for each card in group "k" of unit "i".

Command Format: [OFFmCnUiP]

m = card output (m = # from 1-4)
k = group number (k = # from 1-9)
i = unit number (i = # from 0-9)

Example:

1. **[OFF1G5U1]:** Turns OFF output 1 for each card in group 5 of unit 1.
2. **[OFFG5U1]:** Turns OFF all outputs for each card in group 5 of unit 1.

[OFF.....P]: sets path

This command will set the path for the output, but it is not active until the switch command, [SW], is executed. Commands ending in "P" are not executed immediately. The path for outputs on multiple cards or the same card can be preloaded.

Command Format: [OFFmCnUiP]

m = number (m = 1 to 4)
n = card ID No. (n = a slot # from 1 to 19)
P = path

Example:

If 2 cards are in slots 6 and 7 of unit 3:

To disable outputs 1 and 2 of card 6 and outputs 3 and 4 of card 7 simultaneously, use the following commands:

```
[OFF12C6U3P]
[OFF34C7U3P]
[SW]
```

If "F" is included use the [OFFmCnUiPF] command or the [OFFmCnUiFP] command.

[OFF.....F]: feedback

After processing a command, an OK ER will be returned as feedback if "F" is included at the end of a command string.

Example:

```
[OFF1C2U3F]: if path is not set
[OFF1C2U3PF]: if path is set
```

7. [...S] – Save

This command will save the configuration command being sent in memory. When sending the command [ON1C4S], after reset or power up, output 1 on C4 will be enabled.

8. [...F] – Feedback

After processing a command, an OK or ER will be returned as feedback if "F" is included at the end of a command string.

9. [...P] – Path

This command will set the path for the output, but it is not active until the switch command, [SW], is executed. Commands ending in "P" are not executed immediately. The path for outputs on multiple cards or the same card can be loaded. See examples in ON and OFF commands.

10. [SW] – Switch

The switch command immediately connects inputs and outputs, which were previously set with the PATH command on this card and all other cards in the MT100-100.

11. [HELP]

This command displays all information available for user Multi-Tasker interface commands.

Command Format: [HELPCnUi]

Cn = card ID number (n = # from 1 to 19)

Ui = Unit ID (i = # from 0 to 9) (refer to the MT100-100 user's guide for explanation)

Example:

In order to view the RS-232 commands available for the MT108-103 card in slot 2 of unit 3, send the command [HELPC2U3]. The commands along with a brief description will be displayed in the Terminal Window.

12. [WR]

This command groups multiple cards in the MT100-100 Enclosure. Each unit contains a maximum of nine groups.

Command Format: [WRCn...GkUi]

n = card ID No. (n = slot # from 1 to 19)

k = group number (k = # from 1-9)

i = unit number (i = # from 0-9)

Example:

To group cards #1, 2, and 3 as group 5 of unit #1, send the command [WRC1C2C3G5U1]. After executing this command, cards 1, 2, and 3 of unit 1 will be grouped together as group 5.

13. [CLR]

This command clears the members for a single group or for all nine groups.

Command Format: [CLRGkUi]

k = group number (k = # from 1-9)

i = unit number (i = # from 0-9)

Example:

- To clear group #1, send the [CLRG1U1] command. This command clears the members for the specified group only.
- To clear all groups of unit 1, send the [CLRG*U1] command.

14. [G]

This command is used to request group data. With the command, the user can identify which input or output of a particular group is on.

Command Format: [GkUi]

k = group number (k = # from 1-9)

i = unit number (i = # from 0-9)

Example:

If group 1 has DA Cards with outputs 1 and 2 on, while group 2 has SW Cards with input 2 on:

[G1]: will return feedback as **ON12 G1U0.**

[G2]: will return feedback as **ON2 G2U0.**

15. [RD]

This command displays the members in each group. Members can be any card in enclosure slots 1 to 19.

Command Format: [RDGkUi]

k = group number (k = # from 1-9)

i = unit number (i = # from 0-9)

Example:

To read member data for group 1 of unit 1, send the [RD] command. The system will return feedback as C1C2C3 G5U1.

7.3 SUMMARY OF COMMANDS

- 1) [VER] Receives software version
- 2) [C] Receives status of the card
- 3) [CiS] Save card configuration
- 4) [SIGCi] Check for input signal
- 5) [ON] Turns on one or more outputs for a single card or a group of cards
- 6) [OFF] Turns off one or more outputs for a single card or a group of cards
- 7) [...S] Save the command configuration
- 8) [...F] Provides feedback upon sending
- 9) [...P] Sets the path, preload for [SW]
- 10) [SW] Switch, preloaded outputs
- 11) [HELP] Display available commands
- 12) [WR] Groups multiple cards
- 13) [CLR] Clears members of a single group or all groups
- 14) [G] Requests group data
- 15) [RD] Displays group members

TROUBLESHOOTING GUIDE 8

We have carefully tested and have found no problems in the supplied **MT108-102/(103)**; however, we would like to offer suggestions for the following:

8.1 LED IS NOT LIT

Cause 1: Card cage is not plugged in.

Solution: Plug card cage in. If the LED lights, the problem is solved. If the LED is still not ON, see Cause 2.

Cause 2: Card is not plugged in all the way.

Solution: Push the card in all the way. If the LED is still not ON, see Cause 3.

Cause 3: Card cage slot has a problem.

Solution 1: Test the card in other slots of the card cage. If the slot was damaged, the card may work in other slots. If other slots work and the LED lights, the problem is the card cage slot. The card cage may require service. Call ALTINEX at (714) 990-2300. If the other slots do not work and the LED is still not lit, see Solution 2.

Solution 2: Take any other known good card with an LED and verify that the slot used is good by seeing if the other card's LED lights in that slot. If it lights, then the original card may be the source of the problem. Call ALTINEX at (714) 990-2300.

8.2 NO SOUND

Cause 1: The source has a problem.

Solution: Check the source and make sure that it is working at an appropriate volume level and all source connections are correct. If the source is working and there is still no sound, see Cause 2.

Cause 2: The card output is turned OFF.

Solution 1: Turn ON the card output that is used. See RS-232 accessible commands in section 7. If no sound is present, see Solution 2.

Solution 2: If there is still no sound, see Cause 3.

Cause 3: Cable connections to the destination are incorrect.

Solution: Make sure that all cables are properly connected. Also, make sure that the continuity and wiring are good. If there is still no sound present, see Cause 4.

Cause 4: The destination amplifier has a problem.

Solution 1: Make sure that the destination amplifier has power. If there is still no sound, see Solution 2

Solution 2: Set the volume of the destination amplifier to a reasonable level. If there is still no sound, call ALTINEX at (714) 990-2300.

8.3 SOUND DISTORTION

Cause 1: The source level is above 1V p-p.

Solution: Make sure that the source level is below 1V p-p. If the sound is still distorted, see Cause 2.

Cause 2: The destination amplifier provides excessive amplification.

Solution 1: Make sure that the source signal level is high enough so that the destination amplifier does not have to provide excessive amplification and thereby distort the signal. If there is still sound distortion, see Solution 2.

Solution 2: Call ALTINEX at (714) 990-2300.

8.4 SOUND LEVEL IS LOW

Cause 1: The volume levels are inappropriate.

Solution 1: Turn up the source volume. If sound level is still low, see Solution 2.

Solution 2: Turn up the destination amplifier volume. If the sound level is still low, see Cause 2.

Cause 2: Poor signal transmission.

Solution: Check the cables for continuity and make sure that connections are wired properly to verify that there is good signal transmission.

Note: Test the system by removing the **MT108-102/(103)** card from between the source and the destination amplifier. If the problem persists, call ALTINEX at (714)-990-2300.

ALTINEX POLICY

9

9.1 LIMITED WARRANTY/RETURN POLICY

Please see the Altinex website at www.altinex.com for details on warranty and return policy.

9.2 CONTACT INFORMATION

ALTINEX, INC

592 Apollo street

Brea, CA 92821 USA

TEL: 714 990-2300

TOLL FREE: 1-800-ALTINEX

WEB: www.altinex.com

E-MAIL: solutions@altinex.com