

INSTRUCTIONS FOR ATTACHING LYTESPOT® TO LYTESPAN® TRACK

INSTRUCTION SHEET NO.

IS:7521

R0490

FOR USE WITH LYTESPAN® TRACK SYSTEMS ONLY.

READ AND UNDERSTAND THESE INSTRUCTIONS BEFORE INSTALLING FIXTURE.

This fixture is intended for installation in accordance with the National Electrical Code and local regulations. To assure full compliance with local codes and regulations, check with your local electrical inspector before installation. To prevent electrical shock, turn off electricity at fuse box before proceeding.

Retain these instructions for reference.

INSTRUCTIONS FOR ATTACHING LYTESPOT® TO SINGLE CIRCUIT TRACK

1. Align BEAD on LYTESPAN TRACK and GROOVE in FITTING before inserting into LYTESPAN TRACK. See Fig. 1. (If BEAD is NOT aligned, a potential hazard may result.)
2. Unscrew the TURN KNOB partially and position LEVER. See Fig. 1.
3. To attach FITTING, squeeze BUTTON and KNOB, insert into LYTESPAN TRACK, and release. Tighten TURN KNOB. This holds FITTING to LYTESPAN TRACK mechanically. To energize turn LEVER all the way until LEVER is parallel to LYTESPAN TRACK. See Fig. 2.
4. To shift fixture location on the LYTESPAN TRACK loosen TURN KNOB slightly, release LEVER and slide to new position.
5. To remove fixture reverse the procedure in (3), push TURN KNOB in and allow FITTING to disengage.
6. Fixture can be left on LYTESPAN TRACK when not in use by turning LEVER to disconnect electrically.

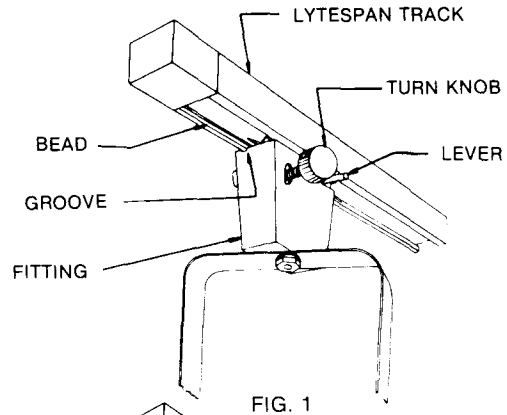

FIG. 1

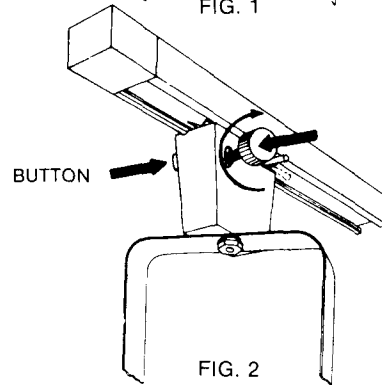

FIG. 2

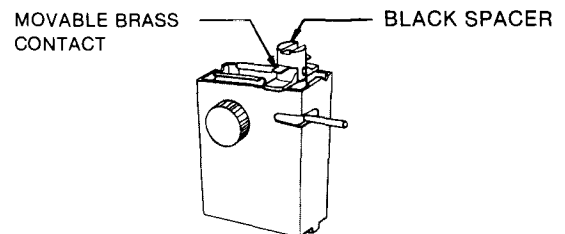

FIG. 3

INSTRUCTIONS FOR CONVERTING LYTESPOT ATTACHMENT FITTING TO OPERATE ON ADVENT LYTESPAN TRACK (2 CIRCUIT)

NOTE: To insure proper operation of Lytespots on Two Circuit Lytespan Track, the BLACK SPACER (provided) must be used at all times on the plug assembly.

The BLACK SPACER is not used when operating Lytespots on Single Circuit Track.

LOWER CIRCUIT, FIG. 3:

Illustrates contacts in low position with spacer in place for lower circuit.

UPPER CIRCUIT, FIG. 4 and 5:

To convert attachment fitting for upper circuit, raise BRASS CONTACT to high position (as indicated by dotted line) by pulling CONTACT as high as stop permits and slipping on BLACK SPACER as shown in Fig. 4 and 5.

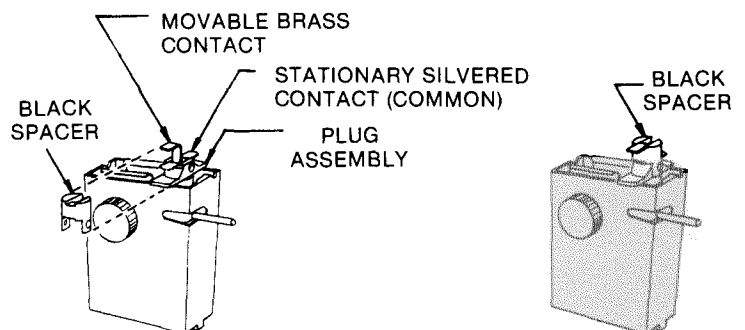

FIG. 4

FIG. 5