

READ AND UNDERSTAND THESE INSTRUCTIONS BEFORE INSTALLING FIXTURE

This fixture is intended for installation in accordance with the National Electrical Code and local regulations. To assure full compliance with local codes and regulations, check with your local electrical inspector before installation. To prevent electric shock, turn off electricity at fuse box before proceeding.

Retain these instructions for maintenance reference.

INSTRUCTION SHEET NO.

IS:4X9EM

A0502

Page 1 of 4

INSTALLATION PROCEDURE FOR: 4X9 AND 9X9 MATRIX SERIES RECESSED COMPACT FLUORESCENT EMERGENCY LIGHTING FRAME-IN KITS

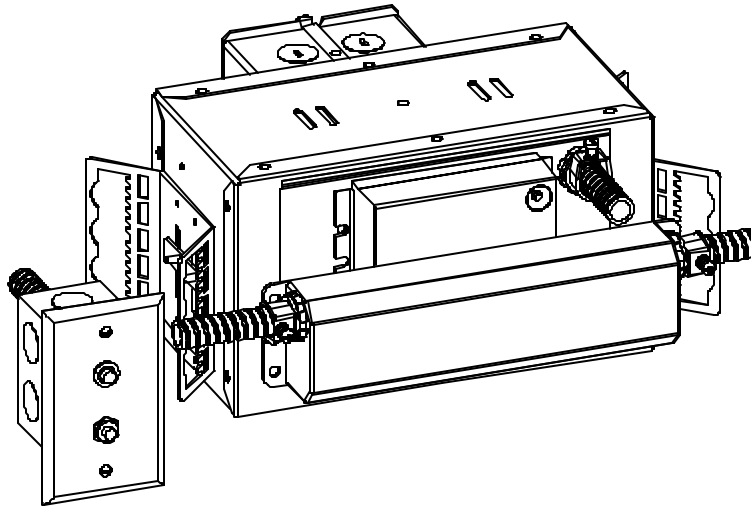

4X9142HUEM Shown.

IMPORTANT SAFEGUARDS

READ AND FOLLOW ALL SAFETY INSTRUCTIONS

WHEN USING ELECTRICAL EQUIPMENT, BASIC SAFETY PRECAUTIONS SHOULD ALWAYS BE FOLLOWED INCLUDING:

1. Turn off AC power before proceeding.
2. Do not use outdoors.
3. Do not mount near gas or electrical heaters.
4. Do not attempt to service the battery. A sealed, rechargeable, no maintenance battery is used. Do not incinerate or mutilate; may burst or release toxic materials. Do not short circuit; may cause burns. Battery acid can cause burns to skin and eyes. If acid is spilled on skin or eyes, flush with fresh water and contact a physician immediately.
5. Equipment should be mounted in locations and at a height where it will not be readily subject to tampering by unauthorized personnel.
6. The use of accessory equipment is not recommended by the manufacturer and may cause an unsafe condition.
7. Do not use the equipment for other than intended use.
8. This unit has more than one power supply connection point. To reduce the risk of electrical shock, disconnect both the normal and the emergency power supplies before servicing.
9. Before servicing to prevent electrical shock, disconnect the battery connectors on the emergency pack (location on the end of the emergency pack). Make certain that the switch (if the fixture is switched) and the unswitched lines to the emergency pack are turned off at the fuse box. Servicing should be performed by qualified personnel only.
10. Be sure all electrical connections are complete before battery (inverter) connectors on emergency Pack are connected.
11. The emergency battery pack must be fed from the same branch circuit as the AC ballast(s).
12. In switched fixtures, emergency pack must be connected ahead of any local switching.
13. Select the appropriate wiring diagrams to connect the emergency pack and the AC ballasts (see page 4).

SAVE THESE INSTRUCTIONS

LIGHTOLIER®

LIGHTOLIER A GENYTE THOMAS COMPANY
631 Airport Road, Fall River, MA 02720

READ AND UNDERSTAND THESE INSTRUCTIONS BEFORE INSTALLING FIXTURE

This fixture is intended for installation in accordance with the National Electrical Code and local regulations. To assure full compliance with local codes and regulations, check with your local electrical inspector before installation. To prevent electric shock, turn off electricity at fuse box before proceeding.

Retain these instructions for maintenance reference.

INSTRUCTION SHEET NO.

IS:4X9EM

A0502

Page 2 of 4

INSTALLATION PROCEDURE FOR: 4X9 AND 9X9 MATRIX SERIES RECESSED COMPACT FLUORESCENT EMERGENCY LIGHTING FRAME-IN KITS

Instructions for replacing BALLAST:

ALL SERVICING MUST BE PERFORMED BY QUALIFIED PERSONNEL ONLY.

1. This unit has more than one power supply connection point. Make certain that the switch (if the fixture is switched) and the unswitched lines to the EMERGENCY BALLAST (see page 3) are turned off at the fuse box.
2. Disconnect the battery pack INVERTER CONNECTORS (Fig. 1), located inside the SWITCH BOX (see page 3) to prevent electrical shock from the battery pack.
3. Remove REFLECTOR TRIM & lamp(s) (See IS:4X4, section E.).
4. Undo WINGNUT(s) and remove UPPER REFLECTOR.
5. Remove SCREWS that secure BALLAST PLATE to HOUSING.
6. Partially remove BALLAST PLATE from HOUSING.
7. Disconnect wire leads from BALLAST push-in terminals.
(Insert pin or paper clip in RELEASE SLOT, Fig. 2a)
8. Remove BALLAST from BALLAST PLATE (Fig. 3), and install new BALLAST.
9. Insert wire leads into BALLAST. Follow appropriate wiring diagram on page 4.
10. Reattach BALLAST PLATE, UPPER REFLECTOR, lamp(s), and REFLECTOR TRIM.

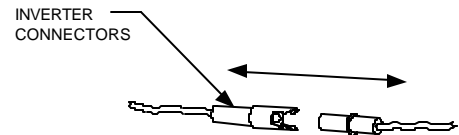

FIG. 1

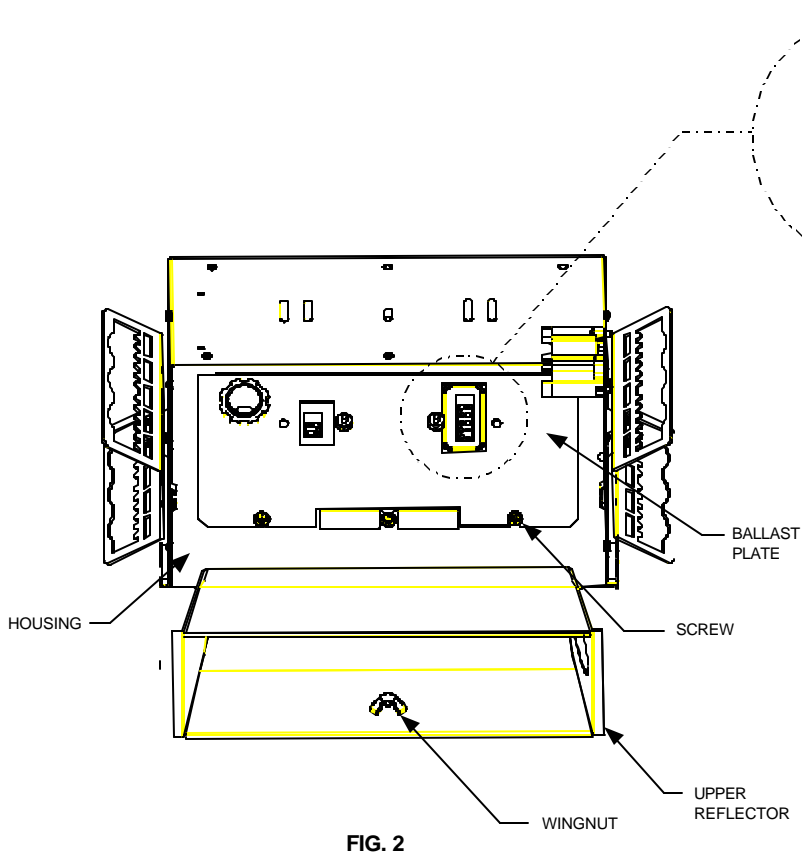

FIG. 2a

FIG. 2

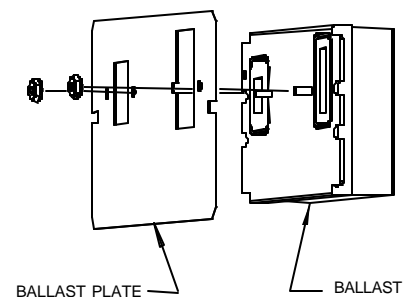

FIG. 3

LIGHTOLIER®

LIGHTOLIER A GENIYTE THOMAS COMPANY
631 Airport Road, Fall River, MA 02720

READ AND UNDERSTAND THESE INSTRUCTIONS BEFORE INSTALLING FIXTURE

This fixture is intended for installation in accordance with the National Electrical Code and local regulations. To assure full compliance with local codes and regulations, check with your local electrical inspector before installation. To prevent electric shock, turn off electricity at fuse box before proceeding.

Retain these instructions for maintenance reference.

INSTRUCTION SHEET NO.

IS:4X9EM

A0502

Page 3 of 4

INSTALLATION PROCEDURE FOR: 4X9 AND 9X9 MATRIX SERIES RECESSED COMPACT FLUORESCENT EMERGENCY LIGHTING FRAME-IN KITS

Instructions for replacing EMERGENCY BALLAST:

ALL SERVICING MUST BE PERFORMED BY QUALIFIED PERSONNEL ONLY.

1. This unit has more than one power supply connection point. Make certain that the switch (if the fixture is switched) and the unswitched lines to the EMERGENCY BALLAST are turned off at the fuse box.
2. To remove SWITCH BOX from ceiling: Disconnect the battery pack inverter connectors (see page 2) located inside the SWITCH BOX to prevent electrical shock from the battery pack. Disconnect switch and indicator light leads, and locknut inside SWITCH BOX. Remove SWITCH BOX.
3. Disconnect all EMERGENCY BALLAST connections inside fixture JUNCTION BOX.
4. Disconnect all leads from A/C BALLAST. DO NOT disconnect any wire leads from lamp socket(s). Remove LOCKNUT from BALLAST PLATE, and remove BALLAST PLATE with A/C BALLAST. See page 2 for detailed instructions on A/C BALLAST removal and replacement.
5. Loosen RETAINING SCREW on EMERGENCY BALLAST MOUNTING BRACKET, and lift EMERGENCY BALLAST MOUNTING BRACKET from HOUSING wall.
6. Feed EMERGENCY BALLAST MOUNTING BRACKET and EMERGENCY BALLAST through opening.
7. Remove emergency ballast from MOUNTING BRACKET and replace with new EMERGENCY BALLAST.
8. Re-install all hardware, including fiberglass sleeves over wiring.
9. Re-connect all electrical connections. Follow appropriate wiring diagram on page 4.

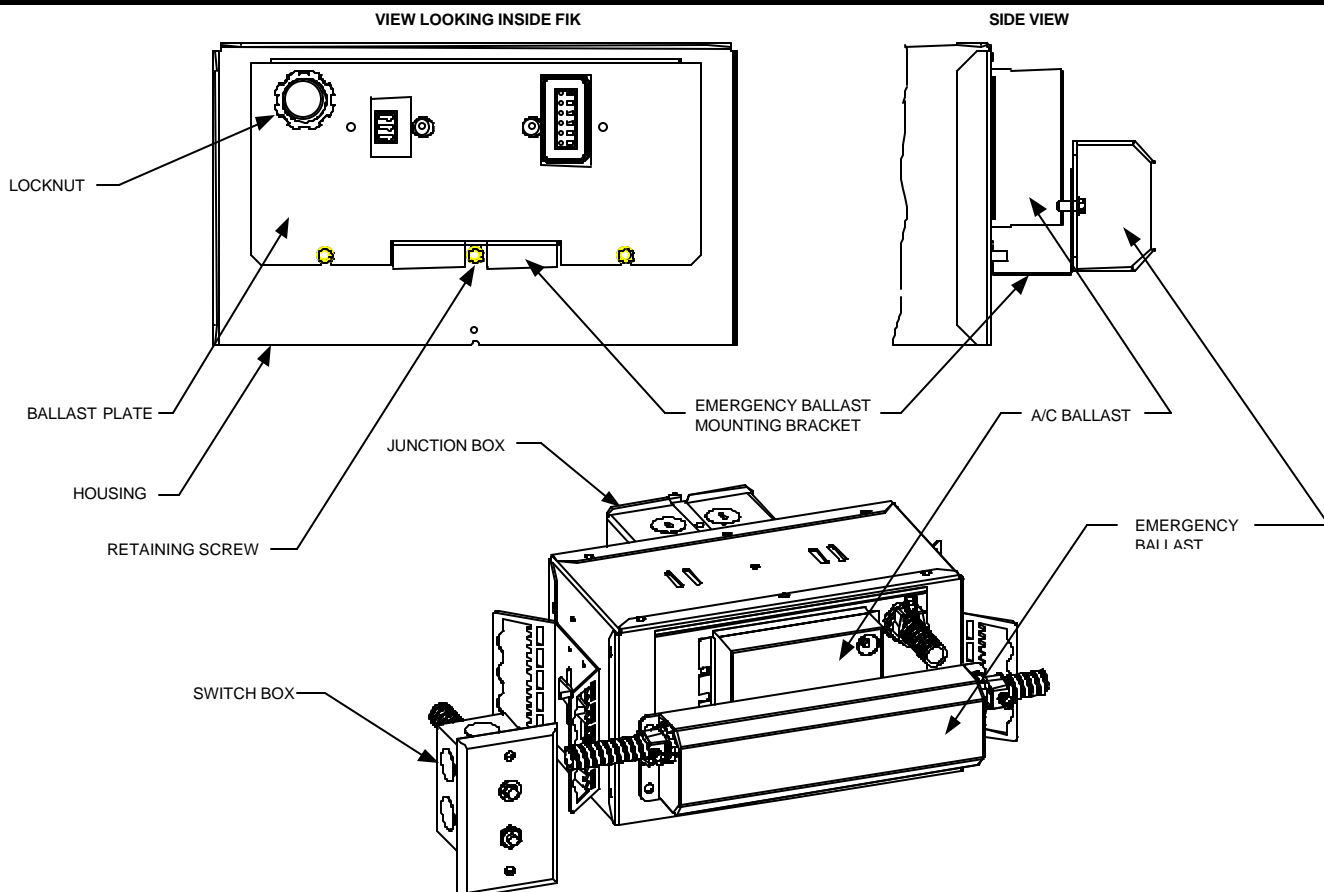

LIGHTOLIER®

LIGHTOLIER A GENIE/THOMAS COMPANY
631 Airport Road, Fall River, MA 02720

READ AND UNDERSTAND THESE INSTRUCTIONS BEFORE INSTALLING FIXTURE

This fixture is intended for installation in accordance with the National Electrical Code and local regulations. To assure full compliance with local codes and regulations, check with your local electrical inspector before installation. To prevent electric shock, turn off electricity at fuse box before proceeding.

Retain these instructions for maintenance reference.

WIRING DIAGRAM #1 – 120-277V (26W, 32W, 42W, 4-PIN QT), SINGLE LAMP (4X4 AND 4X9 SERIES)

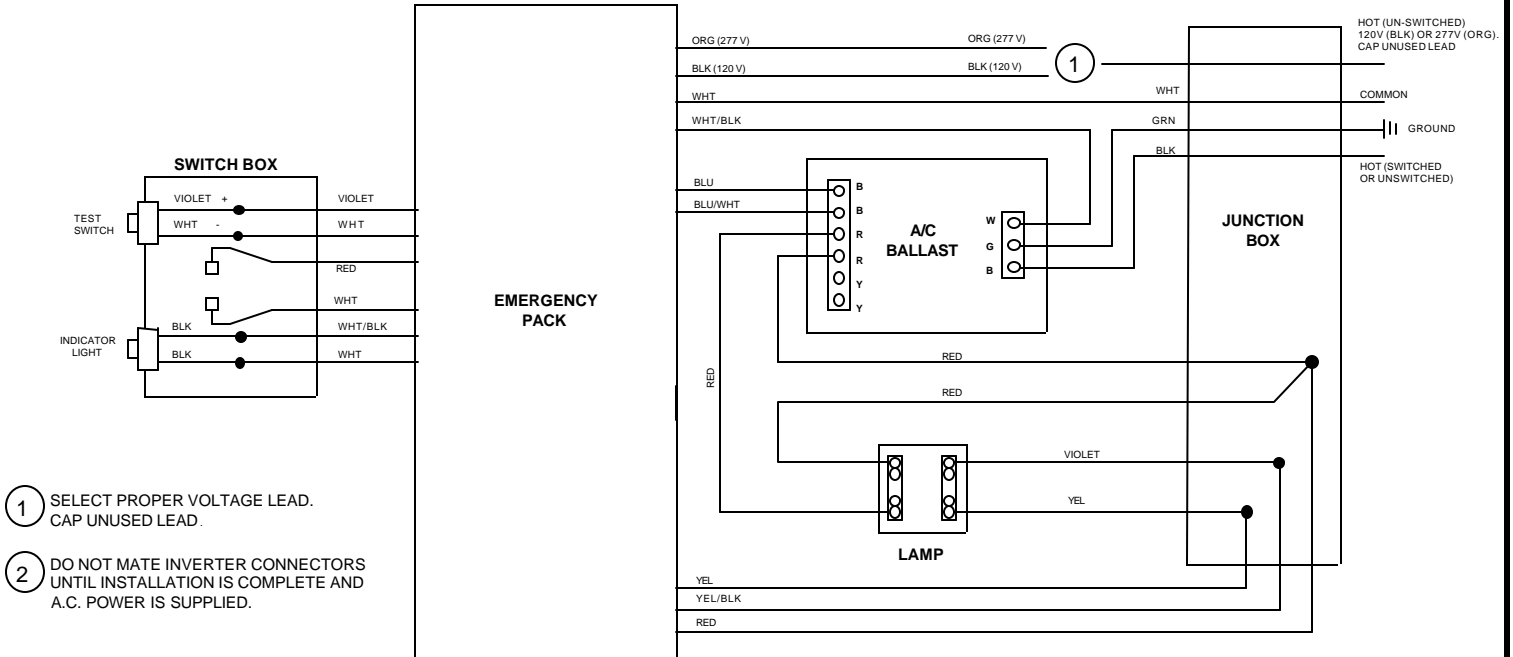

WIRING DIAGRAM #2 – 120-277V (26W, 32W, 42W, 4-PIN QT), DUAL LAMP (9X9 SERIES) (LAMP 2 OPERATES IN EMERGENCY MODE)

