



INSTALLATION INSTRUCTIONS

VR910M/VR914M VANDAL RESISTANT TRIM

FOR USE WITH MORTISE DEVICES

- 1** PREPARE PUSH SIDE OF DOOR FOR EXIT DEVICE. SEE EXIT DEVICE INSTRUCTIONS FOR PREPARATION.
- 2** PREPARE PULL SIDE OF DOOR FOR TRIM.
 - A** TRANSFER VERTICAL AND HORIZONTAL DEVICE CENTER LINES FROM PUSH SIDE OF DOOR TO PULL SIDE.
 - B** LOCATE AND PREPARE ALL HOLES AS INDICATED BELOW.

OUTSIDE FACE OF LOCK STILE RHR SHOWN
LHR OPPOSITE

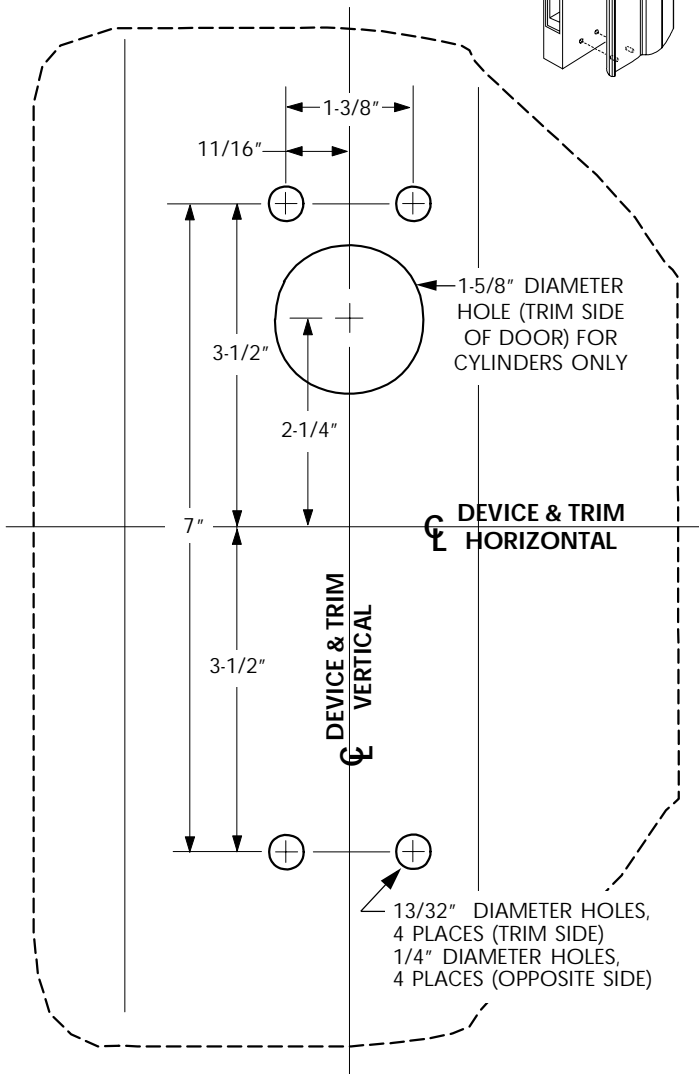
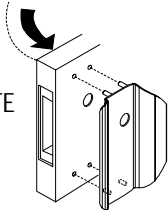

- 3** INSTALL MORTISE LOCK. SEE MORTISE LOCK INSTRUCTIONS.
- 4** INSTALL EXIT DEVICE AND TRIM.

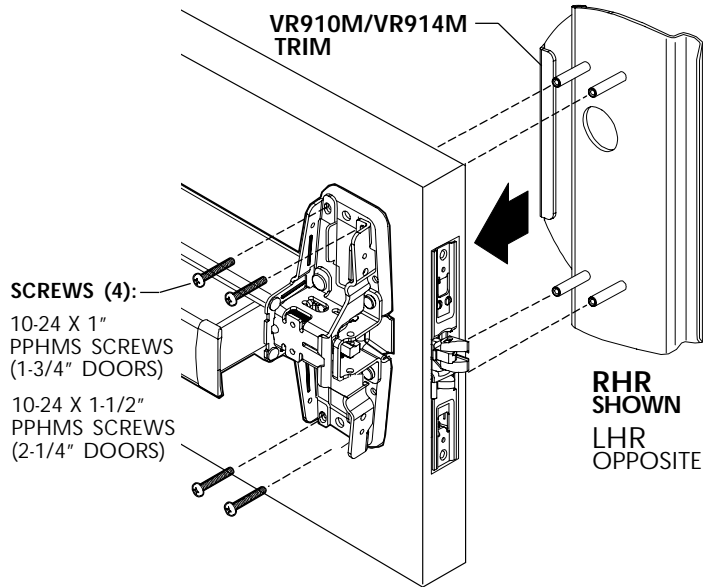

- 5** INSTALL CYLINDER, IF USING.

