

MECHANICAL SPECIFICATIONS

DIMENSIONS

FIXTURE	BOXED FOR SHIPPING
in: 12.0 x 19.6 x 23.8	in: 20 x 26 x 32
mm: 295 x 497 x 604	mm: 506 x 657 x 809
Weight: 25.9 kg (57 lb)	Weight: 39 kg (85 lb)

Mounting Information:

Studio Color 575 may be mounted by attaching suitable clamps with locking washers through the center holes on the base of the fixture. Cheeseborough truss clamps and 1/2" nut/bolt sets may be purchased separately. Studio Color 575 can also be stood on its rubber feet on a sturdy, stable surface.

Colors Available: Black

Turning Radius: 18.75 in (476.3 mm)

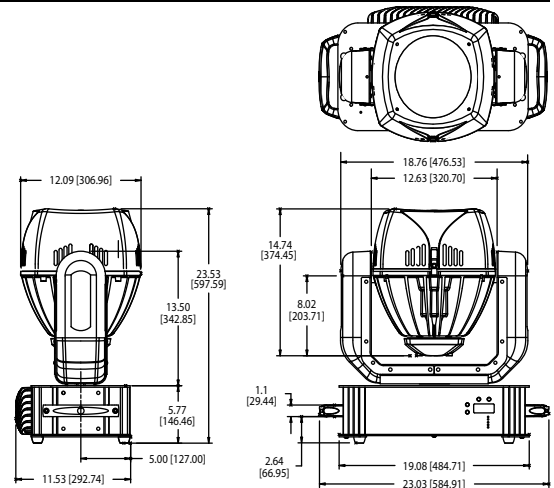

ELECTRICAL SPECIFICATIONS / LIGHT SOURCE

Lamp	MSR 575/2 or optional MSD 575 for longer lamp life	
Power Consumption	100V, 50/60HZ @ 7.0A 230V, 50/60HZ @ 3.0A	
Rated Power	700W max	
Power Factor	0.96 @ 230V/50HZ 0.99 @ 100V/60HZ	
	MSR 575/2	MSD 575
Light output	12,000 ANSI lumens	10,000 ANSI lumens
Lamp life	500 - 750 hours	3000 hours
Color temperature	6200K	5600K

	Center Beam Candela	Beam Angle Degrees	Field Angle Degrees
	360,000	8	17
Throw	Center Beam	Beam Diameter	Field Diameter
5	14,400	0.7	1.5
10	3,600	1.4	3.0
15	1,600	2.1	4.5
20	900	2.8	6.0
25	576	3.5	7.5
30	400	4.2	9.0
35	294	4.9	10.5
40	225	5.6	12.0
45	178	6.3	13.5
50	144	7.0	14.9
55	119	7.7	16.4
60	100	8.4	17.9
65	85	9.1	19.4
70	73	9.8	20.9
75	64	10.5	22.4
80	56	11.2	23.9
85	50	11.9	25.4
90	44	12.6	26.9
95	40	13.3	28.4
100	36	14.0	29.9

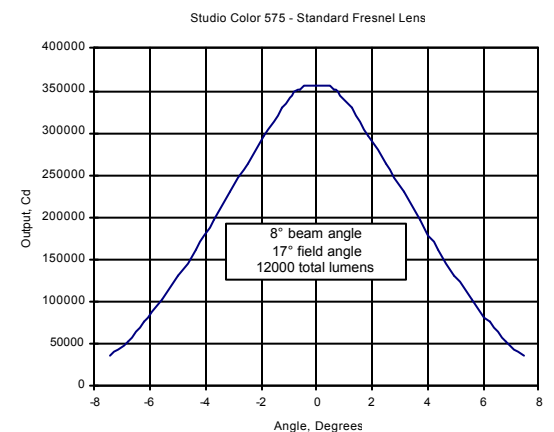

For Metric figures, read "Center Beam" values as in lux, and the throw and diameters will be in meters.
For US figures, read "Center Beam" values as in footcandles, and the throw and diameters will be in feet.

$$\text{Illuminance} = \frac{\text{Candela}}{\text{Distance}^2}$$

OPERATION

Pan: 370° **Tilt:** 240°
Field Angle: 17°

Control Options: DMX-512, On Board Programming/Playback, Time Code Sync, Internal Effects, Fixture Talkback
Address Methods: LED Display, Fixture Talkback

Software Upgrades Operating software may be downloaded from the High End Systems web site (www.highend.com), and uploaded using a High End Systems dongle

Compliances Studio Color 575 is CE, CETL, and ETL compliant.

DMX connectors 3-pin male and female XLR connectors

Environmental Tolerances Maximum ambient temperature, Ta: 40°C (104°F) Maximum exterior surface temperature: 140°C (284°F)
Maximum winding temperature, Tw: 130°C (266°F) Maximum capacitor temperature, Tc: 85°C (185°F)

PART NUMBERS

Fixtures
26010011 - Studio Color 575 MSR Automated Wash Fixture, w/lamp
26010012 - Studio Color 575 MSD Automated Wash Fixture, w/lamp

Accessories
55040015 - Studio Color Snoot
99090029 - Studio Color PAR 64 Lens Set

Lamps
55030050 - Studio Color 575 Replacement Lamp, Philips MSD 575
55030052 - Studio Color Replacement Lamp, Philips MSR 575-2

Controllers
26020001 - Studio Color LCD Controller, 115/230V

Flight Cases
26070000 - Road Case, Studio Color, Single Fixture
26070003 - Road Case, Studio Color, Dual Fixtures

DMX CHANNELS

Channel	Function
1	Pan Coarse
2	Pan Fine
3	Tilt Coarse
4	Tilt Fine
5	Color Functions
6	Color Wheel
7	Cyan Mix
8	Magenta Mix
9	Yellow Mix
10	Lens Wheel (Effects Wheel 1)
11	Frost Wheel (Effects Wheel 2)
12	Shutter
13	Dim
14	Motor Speed
15	Control
16	Checksum

DMX Channels: 16 Fixtures per Universe: 36
 Internal Preset Scene Memory: 1 bank, 16 scenes

COLOR WHEEL

Position	Description	Replaceable
1	Open	No
2	CTO*	Yes
3	Pink	Yes
4	Magenta	Yes
5	Red	Yes
6	Aqua	Yes

Studio Color 575 features CMY subtractive color mixing.



*Corrects to 3100°K for MSR 575/2 lamp and to 2800°K for MSD 575 lamp

Dichroic Glass Diameter: 1.745 in ± 0.010 in (44.323 mm ± 0.25 mm)
 Thickness: 0.070 in ± 0.010 in (1.778 mm ± 0.25 mm)

EFFECTS WHEEL

Effects Wheel 1: Beam Shaping

Effects Wheel 2: Beam Shaping

Position	Description
1	Open
2	Variable Wide Angle Lens
3	Narrow Horizontal Shaping Center Axis
4	Wide Vertical Shaping Center Axis

Position	Description
1	Open
2	Variable Frost Lens
3	Narrow Vertical Shaping Center Axis
4	Wide Horizontal Shaping Center Axis