

Product Features

- Infrared sensor technology
- Manual temperature adjustment
- Battery operated – 6 V lithium battery
- 1.3 gpm
- Automatic shutoff after 1 minute
- Flexible supply hoses with 3/8" adapters

Code Compliance

This unit meets or exceeds the following:

- ADA compliant

Available Finishes

Chrome	10101001
Steel Optik	10101801

Optional Accessories

Grid drain, chrome	06400000
Grid drain, steel	06400800

Installation Notes

- Not for use with continuous flow water heater
- Do not use on sink with raised lip

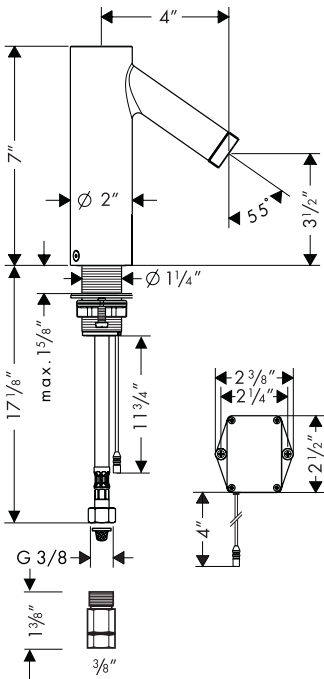

The measurements shown are for reference only.

Products and specifications shown are subject to change without notice.

Specification sheet revised 01/2008