

RKS-140RS-48-10B & RKS-140RS-49-10B Installation Instructions

Installation instructions for converting two-lamp (or more), industrial and strip type, fluorescent fixtures to Rapid Start, single-lamp, 48" and 49 3/4" reflectorized fluorescent fixtures.

Contents

- 1 - 48 1/2" or 49 3/4" reflector
- 1 - 40" steel channel cover
- 2 - #800 URS socket brackets
- 2 - #953 lamp holders / sockets
- 4 - #8 TEK screws
- 2 - quarter-turn fasteners
- 2 - self-tapping loc-screws
- 2 - wire connectors



- WARNING!** - Risk of fire or electrical shock. Reflector kit installation requires knowledge of fluorescent lighting fixture electrical systems. If not qualified, do not attempt installation. Contact a qualified electrician.
- WARNING!** - To prevent wiring damage or abrasion, do not expose wiring to edges of sheet metal or other sharp objects. Reflector kit is not intended to be used for damp or wet locations.
- WARNING!** - Risk of fire or electrical shock. Fixture wiring, ballast or other electrical parts may be damaged when drilling for installation of reflector kit hardware. Check for enclosed wiring and components.
- WARNING!** - Do not make or alter any open holes in an enclosure of wiring or electrical components during kit installation.

Selecting a ballast - When selecting a ballast, the following considerations should be made. Use only UL Listed, Class P, thermally protected ballast. It should be suitable for lamps / lamp holders type. It should not exceed voltage and wattage rating. Ballast leads should be of proper length to avoid splicing. Primary voltage of ballast should be selected according to supply source voltage.

1. - Disconnect Power
2. - Remove and discard lamps, existing channel covers, socket brackets and ballast. Retain only a bare channel and channel end caps. Please dispose of lamps and ballast properly and recycle if possible.
3. - With bare channel, now begin installation of new retrofit kit.
4. - Prewire lamp holders / sockets. Insert lamp wire leads of new ballast into #953 RS socket wire terminals. This should be completed according to the ballast manufacturer's wiring diagram printed on the ballast label.
5. - Install ballast with sockets attached to leads into channel. Make connections of supply wire to ballast using provided wire connectors.

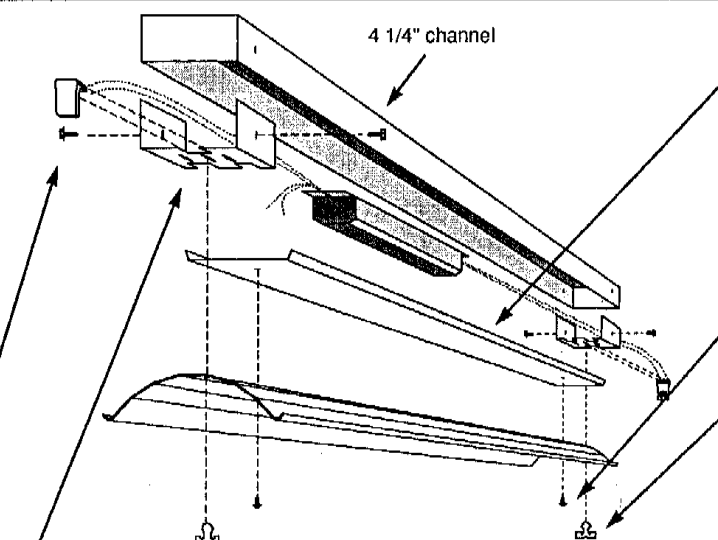

6. - Beginning at one end of the channel, install appropriate pre-wired socket into first #800 URS bracket. Using #8 TEK screws, attach the bracket flush with the end of the fixture channel.

7. - Using steel channel cover as a spacing jig, place opposite bracket in place and attach with #8 TEK screws. (Spacing between brackets is 40")

Note: When converting an 8' section of fixture, feed the remaining two pre-wired #953 sockets above the bracket. Repeat steps #6 and #7 placing center two brackets back-to-back.

8. - Using self-tapping loc-screws, attach reflector to the steel channel cover.

9. - Snap quarter-turn fasteners into holes at each end of the reflector.

10. - Attach reflector and steel channel cover to the socket brackets using slots in brackets.

11. - Remove protective film coating and install lamps.

12. - Re-connect power.

Note: Dimensions and specifications may change without notice.

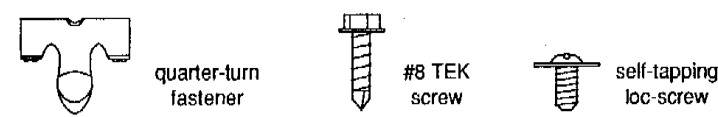

031893