

## DESCRIPTION

A series of Open and Closed Back styled lampholders available for use with a variety of lamp types. The clean, minimal stem and fine design of the open back version allows the lamp to be part of the design, while the ample closed back version removes the lamp from the design, thus creating an all-together different aesthetic.

## APPLICATION

Ideal for accent and display applications. The Open and Closed Back 50W MR16 versions offer their own unique styling to complement any space.

## SPECIFICATION FEATURES

### A ... Electrical Quick Lock Adapter

Polycarbonate housing. Attaches electrically and mechanically anywhere along Linea track.

### B ... Arm

Round aluminum arm allows lampholder to rotate 330° and provides 0° to 90° vertical pivot for maximum aiming adjustability.

### C ... Lockable Tilt

Lampholder tilt can be locked in place easily with the use of a 1.5mm allen wrench.

### D ... Lampholder Body

Die Cast Aluminum housing provides durability and good thermal performance.

### E ... Cover Glass

Fixture provided with cover glass (required for use with non-open fixture rated lamps).

### Labels

UL/c-UL Listed for use with Linea Track.

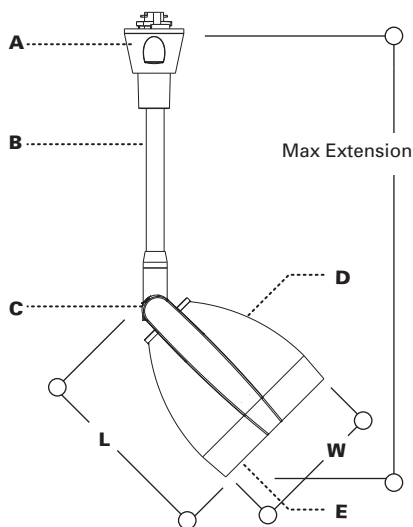

H=2.56" [65mm]  
W=2.56" [65mm]  
Max Extension=  
7.6" [193mm]



**LV202CB16**  
**LV20216**

**Span**  
**50W MR16 Accent**  
**Flexible Track**

<b>LV</b>	<b>2</b>	<b>02</b>		<b>16</b>	<b>AH</b>	
<b>Track</b> LV=Linea Track	<b>Lamp Type</b> 2=Low Voltage	<b>Series</b> 02=Span	<b>Style</b> Blank=Open Back CB= Closed Back	<b>Lamp</b> 16=MR16	<b>Finish</b> AH=Aluminum Haze	<b>Accessories</b> LM20216AH=Media Holder L100 Series Lenses L100MB Hex Cell Louver

### IMPORTANT!

Lampholder is ready to install on Linea track. To install lampholder on other Cooper Lighting Track Systems, converters and/or transformers are required.

**L100 Series 2"50mm UV and Color Filters**

For use with MR16 Lampholders. Make a powerful lighting statement by injecting soft or intense hues to accent any space.

L112=Red Gel Filter  
 L114=Ultraviolet, Dichoric Filter  
 L120=Red, Dichroic Filter  
 L121=Amber, Dichroic Filter  
 L122=Yellow, Dichroic Filter  
 L123=Green, Dichroic Filter  
 L124=Daylight Blue, Dichroic Filter  
 L125=Blue, Dichroic Filter  
 L127=Cosmetic (2700<sup>o</sup>K), Dichroic Filter  
 L130=Yellow Gel Filter  
 L131=Amber Gel Filter

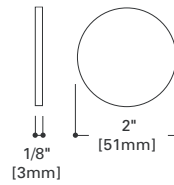

**L100 Series UV and Color Filters**

**L100 Series 2"50mm UV and Color Filters**

For use with MR16 Lampholders. Make a powerful lighting statement by injecting soft or intense hues to accent any space.

L112=Red Gel Filter  
 L114=Ultraviolet, Dichoric Filter  
 L120=Red, Dichroic Filter  
 L121=Amber, Dichroic Filter  
 L122=Yellow, Dichroic Filter  
 L123=Green, Dichroic Filter  
 L124=Daylight Blue, Dichroic Filter  
 L125=Blue, Dichroic Filter  
 L127=Cosmetic (2700<sup>o</sup>K), Dichroic Filter  
 L130=Yellow Gel Filter  
 L131=Amber Gel Filter

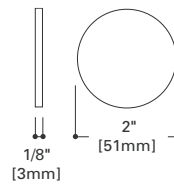

**L100 Series UV and Color Filters**